



Report on

GEN-2025-SR27 Surplus Interconnection Service Impact Study

Revision R1 May 5, 2026

Submitted to
Southwest Power Pool



anedenconsulting.com

TABLE OF CONTENTS

Revision History	R-1
Executive Summary	ES-1
1.0 Scope of Study	1
1.1 Reactive Power Analysis	1
1.2 Short Circuit Analysis	1
1.3 Stability Analysis	1
1.4 Steady-State Analysis	1
1.5 Necessary Interconnection Facilities & Network Upgrades	2
1.6 Study Limitations	2
2.0 Surplus Interconnection Service Request	3
3.0 Reactive Power Analysis	6
3.1 Methodology and Criteria	6
3.2 Results	6
4.0 Short Circuit Analysis	8
4.1 Methodology	8
4.2 Results	8
5.0 Dynamic Stability Analysis	10
5.1 Methodology and Criteria	10
5.2 Fault Definitions	11
5.3 Scenario 1 Results	22
5.4 Scenario 2 Results	26
6.0 Necessary Interconnection Facilities and Network Upgrades	30
6.1 Interconnection Facilities	30
6.2 Network Upgrades	30
7.0 Surplus Interconnection Service Determination and Requirements	31
7.1 Surplus Service Determination	31
7.2 Surplus Service Requirements	31

LIST OF TABLES

Table ES-1: EGF & SGF Configuration ES-1
 Table ES-2: SGF Interconnection Configuration..... ES-2
 Table 2-1: EGF & SGF Configuration..... 3
 Table 2-2: SGF Interconnection Configuration 5
 Table 3-1: Shunt Reactor Size for Reactive Power Analysis..... 6
 Table 4-1: Short Circuit Model Parameters* 8
 Table 4-2: POI Short Circuit Comparison Results..... 8
 Table 4-3: 25SP Short Circuit Comparison Results..... 9
 Table 5-1: Study Scenarios (Generator Dispatch MW) 10
 Table 5-2: Fault Definitions..... 11
 Table 5-3: Scenario 1 Dynamic Stability Results (EGF = 0 MW, SGF = 50.32 MW)..... 22
 Table 5-4: Scenario 2 Dynamic Stability Results (EGF = 19.68 MW, SGF = 50.32 MW)..... 26

LIST OF FIGURES

Figure 2-1: GEN-2014-033 Single Line Diagram (EGF Existing Configuration*)..... 4
 Figure 2-2: GEN-2014-033 & GEN-2025-SR27 Single Line Diagram (EGF & SGF Configuration)..... 4
 Figure 3-1: GEN-2025-SR27 Single Line Diagram (Shunt Sizes)..... 7

APPENDICES

- APPENDIX A: GEN-2025-SR27 Generator Dynamic Model
- APPENDIX B: Short Circuit Results
- APPENDIX C: Dynamic Stability Results with Existing Base Case Issues & Simulation Plots

Revision History

DATE OR VERSION NUMBER	AUTHOR	CHANGE DESCRIPTION
5/05/2026	Aneiden Consulting	Initial Report Issued

Executive Summary

Aneden Consulting (Aneden) was retained by the Southwest Power Pool (SPP) to perform a Surplus Interconnection Service Impact Study (Study) for GEN-2025-SR27 to utilize the Surplus Interconnection Service being made available by GEN-2014-033 at its existing Point of Interconnection (POI), the Chaves County 115kV Substation in the Xcel Energy, formerly Southwestern Public Service (SPS), control area.

GEN-2025-SR27, the proposed Surplus Generating Facility (SGF), will connect to the existing GEN-2014-033 main collection substation and share its main power transformer.

GEN-2014-033, the Existing Generating Facility (EGF), has an effective Generator Interconnection Agreement (GIA) with a POI capacity of 70 MW and is making 50 MW of Surplus Interconnection Service available at its POI. Per the SPP Open Access Transmission Tariff (SPP Tariff), the amount of Surplus Interconnection Service available to the SGF is limited by the amount of Interconnection Service granted to the EGF at the same POI. In addition, the Surplus Interconnection Service is only available up to the amount that can be accommodated without requiring Network Upgrades except those specified in the SPP Tariff¹.

The proposed SGF configuration consists of 17 x Power Electronics FP4200M Battery Energy Storage System (BESS) inverters operating at 2.96 MW for a total assumed dispatch of 50.32 MW. The inverters are rated at 3.78 MVA, thus the generating capability of the SGF exceeds its requested Surplus Interconnection Service of 50 MW. The injection amount of the SGF must be limited to 50 MW at the POI. The combined generation from both the SGF and the EGF may not exceed 70 MW at the POI. GEN-2025-SR27 includes the use of a Power Plant Controller (PPC) to limit the power injection as required. The SGF and EGF information is shown in Table ES-1 below.

The detailed SGF configuration is captured in Table ES-2 below.

Table ES-1: EGF & SGF Configuration

Request	Interconnection Queue Capacity (MW)	Generator Fuel Type	Point of Interconnection
GEN-2025-SR27 (SGF)	50	Battery/Storage	Chaves County 115kV (527482)
GEN-2014-033 (EGF)	70	Solar	Chaves County 115kV (527482)

¹ Allowed Network Upgrades detailed in SPP Open Access Transmission Tariff Attachment V Section 3.3

Table ES-2: SGF Interconnection Configuration

Facility	SGF Configuration
Point of Interconnection	Chaves County 115kV (527482)
Configuration/Capacity	17 x Power Electronics FP4200M 2.96 MW (Battery/Storage) = 50.32 MW [dispatch] Units are rated at 3.78 MVA, GEN-2025-SR27 limited to 50 MW at the POI and total POI injection w/ GEN-2014-033 limited to 70 MW
Generation Interconnection Line (Shared with the EGF and unchanged from the DISIS-2021-001 Phase 2 Models)	Length = 0.14 miles R = 0.000130 pu X = 0.000780 pu B = 0.000110 pu Rating MVA = 154 MVA
Main Substation Transformer ¹ (Shared with the EGF and unchanged from the DISIS-2021-001 Phase 2 Models)	X = 8.176%, R = 0.25%, Winding MVA = 48 MVA, Rating MVA = 80 MVA
Equivalent GSU Transformer ¹	Gen 1 Equivalent Qty: 17 X = 8.9579%, R = 0.8697%, Winding MVA = 71.4 MVA, Rating MVA = 71.4 MVA
Equivalent Collector Line ²	R = 0.000388 pu X = 0.000406 pu B = 0.000716 pu
Generator Dynamic Model ³ & Power Factor	17 x Power Electronics FP4200M 3.78 MVA (REGCA1) ³ Leading: 0.78319 Lagging: 0.78319

1) X and R based on Winding MVA, 2) All pu are on 100 MVA Base 3) DYR stability model name

SPP determined that steady-state analysis was not required because the addition of the SGF does not increase the maximum active power output of 70 MW. In addition, the EGF was previously studied at maximum Interconnection Service under all necessary reliability conditions.

The scope of this study included reactive power analysis, short circuit analysis, and dynamic stability analysis.

Aneden performed the analyses using the study data provided for the SGF and the DISIS-2021-001 study models:

- 2025 Summer Peak (25SP),
- 2025 Winter Peak (25WP)

All analyses were performed using the Siemens PTI PSS/E² version 34 software and the results are summarized below.

² Power System Simulator for Engineering

The results of the reactive power analysis using the 25SP model showed that the SGF project needed a 0.1 MVar shunt reactor at the project substation to reduce the POI MVar to zero when the EGF project has a shunt compensating for its charging effects. This is necessary to offset the capacitive effect on the transmission network caused by the project's transmission line and collector system during reduced generation conditions. The information gathered from the reactive power analysis is provided as information to the Interconnection Customer and Transmission Owner (TO) and/or Transmission Operator (TOP). The applicable reactive power requirements will be further reviewed by the TO and/or TOP.

The short circuit analysis was performed using the 25SP stability model modified for short circuit analysis. The results from the short circuit analysis compared the 25SP model with the EGF online and SGF not connected to the SGF study model (EGF and SGF online). The maximum contribution to three-phase fault currents in the immediate transmission systems due to the addition of the SGF was not greater than 0.23 kA. The maximum three-phase fault current level within 5 buses of the POI with the EGF and SGF generators online was 32.4 kA for the 25SP model.

The dynamic stability analysis was performed using Siemens PTI PSS/E version 34.8.1 software for the two modified study models: 25SP and 25WP, each with two dispatch scenarios. 116 fault events were simulated, which included three-phase faults and single-line-to-ground stuck breaker faults.

- Scenario 1: SGF at maximum assumed dispatch, 50.32 MW, and EGF disconnected.
- Scenario 2: SGF at maximum assumed dispatch, 50.32 MW, and EGF dispatched with the remaining 19.68 MW for a total combination of 70 MW.

The results of the dynamic stability analysis showed several existing base case issues that were found in both the original DISIS-2021-001 model and in the model with GEN-2025-SR27 included. These issues were not attributed to the GEN-2025-SR27 surplus request and are detailed in Appendix C.

There were no damping or voltage recovery violations attributed to the GEN-2025-SR27 surplus request observed during the simulated faults. Additionally, the project was found to stay connected during the contingencies that were studied and, therefore, will meet the Low Voltage Ride Through (LVRT) requirements of FERC Order #661A.

The results of the study showed that the Surplus Interconnection Service Request by GEN-2025-SR27 did not negatively impact the reliability of the Transmission System. There were no additional Interconnection Facilities or Network Upgrades identified by the analyses.

SPP has determined that GEN-2025-SR27 may utilize the requested 50 MW of Surplus Interconnection Service being made available by the EGF. The combined generation from both the SGF and the EGF may not exceed 70 MW at the POI.

The customer must install monitoring and control equipment as needed to ensure that the SGF does not exceed the granted surplus amount and to ensure that combination of the SGF and EGF power injected at the POI does not exceed the Interconnection Service amount listed in the EGF's GIA. The monitoring and control scheme may be reviewed by the TO and documented in Appendix C of the SGF GIA.

In accordance with FERC Order No. 827, both the SGF and EGF will be required to provide dynamic reactive power within the range of 0.95 leading to 0.95 lagging at the high-side of the generator substation.

It is likely that the customer may be required to reduce its generation output to 0 MW in real-time, also known as curtailment, under certain system conditions to allow system operators to maintain the reliability of the transmission network.

Nothing in this study should be construed as a guarantee of transmission service or delivery rights. If the customer wishes to obtain deliverability to final customers, a separate request for transmission service must be requested on Southwest Power Pool's OASIS by the customer.

1.0 Scope of Study

Aneden Consulting (Aneden) was retained by the Southwest Power Pool (SPP) to perform a Surplus Service Impact Study (Study) for GEN-2025-SR27, the Surplus Generating Facility (SGF). A Surplus Service Impact Study is performed to identify the impact of the Surplus Interconnection Service on the transmission system reliability and any additional Interconnection Facilities necessary pursuant to the SPP Generator Interconnection Procedures (“GIP”) contained in Attachment V Section 3.3 of the SPP Open Access Transmission Tariff (SPP Tariff). The amount of Surplus Interconnection Service available to the SGF is limited by the amount of Interconnection Service granted to the existing interconnection customer for the Existing Generating Facility (EGF) at the same POI. The Surplus Interconnection Service is only available up to the amount that can be accommodated without requiring additional Network Upgrades except those specified in the SPP Tariff³. The required scope of the study is dependent upon the EGF and SGF specifications. The criteria sections below include the basis of the analyses included in the scope of study.

All analyses were performed using the Siemens PTI PSS/E version 34 software. The results of each analysis are presented in the following sections.

1.1 Reactive Power Analysis

SPP requires that a reactive power analysis be performed on the requested configuration if it is a non-synchronous resource. The reactive power analysis determines the added capacitive effect at the POI caused by the project’s collection system and transmission line’s capacitance. A shunt reactor size was determined for the SGF to offset the capacitive effect and maintain zero (0) MVAR injection at the POI while the plant’s generators and capacitors were offline, and the EGF project had a shunt compensating for its charging effects.

1.2 Short Circuit Analysis

SPP requires that a short circuit analysis be performed to determine the maximum available fault current requiring interruption by protective equipment with both the SGF and EGF online, along with the amount of increase in maximum fault current due to the addition of the SGF. The analysis was performed on two scenarios, with the EGF in service and SGF offline, and the modified model with both EGF and SGF in service.

1.3 Stability Analysis

SPP requires that a dynamic stability analysis be performed to determine whether the SGF, EGF, and the transmission system will remain stable and within applicable criteria. Dynamic stability analysis was performed on two dispatch scenarios, the first where the SGF was online at 100% of the assumed dispatch with the EGF offline and disconnected, and the second where the SGF was online at 100% of the assumed dispatch and the EGF was picking up the remaining EGF GIA capacity. The stability analysis will identify any additional Interconnection Facilities and Network Upgrades necessary.

1.4 Steady-State Analysis

The steady-state (thermal/voltage) analyses may be performed as necessary to ensure that all required reliability conditions are studied. If the EGF was not studied under off-peak conditions, off-peak steady state analyses shall be performed to the required level necessary to demonstrate reliable operation of the Surplus Interconnection Service. If the original system impact study is not available for the

³ Allowed Network Upgrades detailed in SPP Open Access Transmission Tariff Attachment V Section 3.3

Interconnection Service, both off-peak and peak analysis may need to be performed for the EGF associated with the request.

An SGF that includes a fuel type (synchronous/non-synchronous) different from the EGF may require a steady-state analysis to study impacts resultant from changes in dispatch to all equal and lower queued requests. The steady-state analyses will identify any additional Interconnection Facilities and Network Upgrades necessary.

1.5 Necessary Interconnection Facilities & Network Upgrades

The SPP Tariff⁴ states that the reactive power, short circuit/fault duty, stability, and steady-state analyses (where applicable) for the Surplus Interconnection Service will identify any additional Interconnection Facilities necessary. In addition, the analyses will determine if any Network Upgrades are required for mitigation. The Surplus Interconnection Service is only available up to the amount that can be accommodated without requiring additional Network Upgrades unless (a) those additional Network Upgrades are either (1) located at the Point of Interconnection substation and at the same voltage level as the Generating Facility with an effective GIA, or (2) are System Protection Facilities; and (b) there are no material adverse impacts on the cost or timing of any Interconnection Requests pending at the time the Surplus Interconnection Service request is submitted.

1.6 Study Limitations

The assessments and conclusions provided in this report are based on assumptions and information provided to Aneden by others. While the assumptions and information provided may be appropriate for the purposes of this report, Aneden does not guarantee that those conditions assumed will occur. In addition, Aneden did not independently verify the accuracy or completeness of the information provided. As such, the conclusions and results presented in this report may vary depending on the extent to which actual future conditions differ from the assumptions made or information used herein.

⁴ SPP Open Access Transmission Tariff Section 3.3.4.1

2.0 Surplus Interconnection Service Request

The GEN-2025-SR27 Interconnection Customer has requested a Surplus Interconnection Service Impact Study (Study) for GEN-2025-SR27 to utilize the Surplus Interconnection Service being made available by GEN-2014-033 at its existing Point of Interconnection (POI), the Chaves County 115kV Substation in the Xcel Energy, formerly Southwestern Public Service (SPS), control area.

GEN-2025-SR27, the proposed SGF, will connect to the existing GEN-2014-033 main collection substation and share its main power transformer.

GEN-2014-033, the EGF, has an effective Generation Interconnection Agreement (GIA) with a POI capacity of 70 MW and is making 50 MW of Surplus Interconnection Service available at its POI. Per the SPP Tariff the amount of Surplus Interconnection Service available to the SGF is limited by the amount of Interconnection Service granted to the EGF at the same POI. In addition, the Surplus Interconnection Service is only available up to the amount that can be accommodated without requiring additional Network Upgrades except those specified in the SPP Tariff.

At the time of the posting of this report, GEN-2014-033 (EGF) is an active existing generator at the same POI (Chaves County 115kV) with a queue status of “IA FULLY EXECUTED/COMMERCIAL OPERATION”. GEN-2014-033 is a solar generation plant, has a maximum summer and winter queue capacity of 70 MW, and has Energy Resource Interconnection Service (ERIS). The EGF was originally studied in the DISIS-2014-002 cluster study. Figure 2-1 shows the power flow model single line diagram for the EGF configuration.

The proposed SGF configuration consists of 17 x Power Electronics FP4200M Battery Energy Storage System (BESS) inverters operating at 2.96 MW for a total assumed dispatch of 50.32 MW. The inverters are rated at 3.78 MVA, thus the generating capability of the SGF exceeds its requested Surplus Interconnection Service of 50 MW. The injection amount of the SGF must be limited to 50 MW at the POI. The combined generation from both the SGF and the EGF may not exceed 70 MW at the POI. GEN-2025-SR27 includes the use of a Power Plant Controller (PPC) to limit the power injection as required. The SGF and EGF information is shown in Table 2-1 below.

Table 2-1: EGF & SGF Configuration

Request	Interconnection Queue Capacity (MW)	Generator Fuel Type	Point of Interconnection
GEN-2025-SR27 (SGF)	50	Battery/Storage	Chaves County 115kV (527482)
GEN-2014-033 (EGF)	70	Solar	Chaves County 115kV (527482)

The proposed detailed SGF configuration is captured in Figure 2-2 and Table 2-2 below.

Figure 2-1: GEN-2014-033 Single Line Diagram (EGF Existing Configuration*)

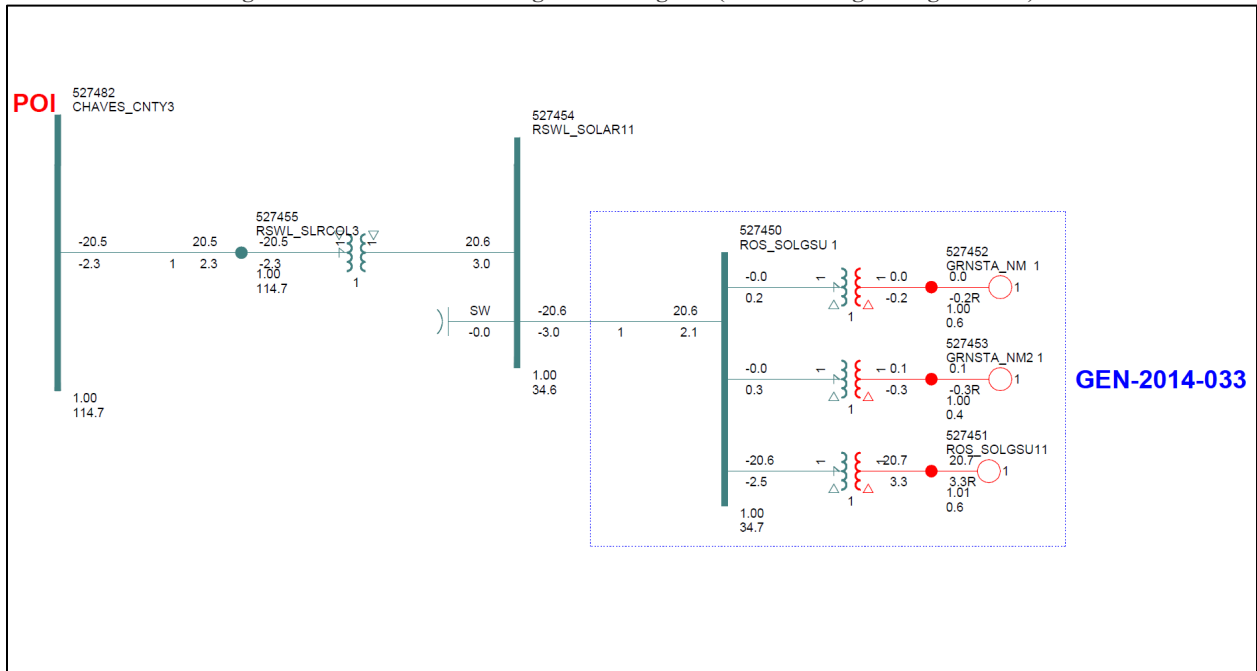

*based on the DISIS-2021-001 25SP stability models

Figure 2-2: GEN-2014-033 & GEN-2025-SR27 Single Line Diagram (EGF & SGF Configuration)

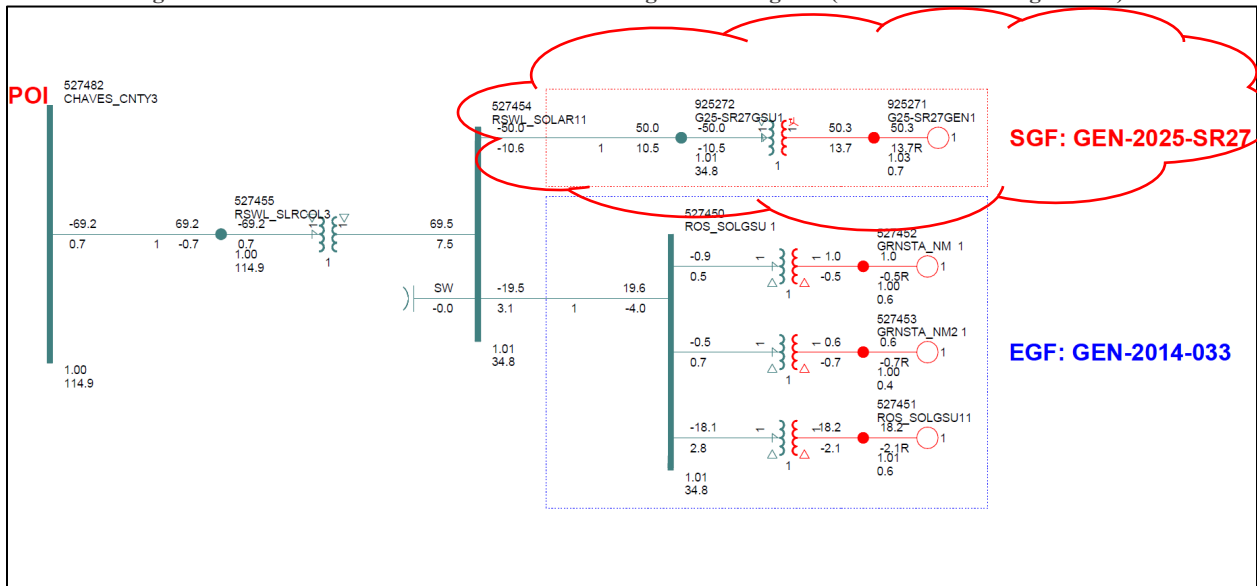

Table 2-2: SGF Interconnection Configuration

Facility	SGF Configuration
Point of Interconnection	Chaves County 115kV (527482)
Configuration/Capacity	17 x Power Electronics FP4200M 2.96 MW (Battery/Storage) = 50.32 MW [dispatch] Units are rated at 3.78 MVA, GEN-2025-SR27 limited to 50 MW at the POI and total POI injection w/ GEN-2014-033 limited to 70 MW
Generation Interconnection Line (Shared with the EGF and unchanged from the DISIS-2021-001 Phase 2 Models)	Length = 0.14 miles R = 0.000130 pu X = 0.000780 pu B = 0.000110 pu Rating MVA = 154 MVA
Main Substation Transformer ¹ (Shared with the EGF and unchanged from the DISIS-2021-001 Phase 2 Models)	X = 8.176%, R = 0.25%, Winding MVA = 48 MVA, Rating MVA = 80 MVA
Equivalent GSU Transformer ¹	Gen 1 Equivalent Qty: 17 X = 8.9579%, R = 0.8697%, Winding MVA = 71.4 MVA, Rating MVA = 71.4 MVA
Equivalent Collector Line ²	R = 0.000388 pu X = 0.000406 pu B = 0.000716 pu
Generator Dynamic Model ³ & Power Factor	17 x Power Electronics FP4200M 3.78 MVA (REGCA1) ³ Leading: 0.78319 Lagging: 0.78319

1) X and R based on Winding MVA, 2) All pu are on 100 MVA Base 3) Dyr stability model name

3.0 Reactive Power Analysis

The reactive power analysis was performed for GEN-2025-SR27 to determine the capacitive charging effects due to the SGF during reduced generation conditions (unsuitable wind speeds, unsuitable solar irradiance, insufficient state of charge, idle conditions, curtailment, etc.) at the generation site, and to size shunt reactors that would reduce the project reactive power contribution to the POI to approximately zero.

3.1 Methodology and Criteria

To determine the shunt reactor size required to compensate for the current charging attributed to the SGF collection system, the reactive power analysis for the EGF was determined first. Once the shunt size for the EGF was determined, the SGF incremental shunt reactor size was then calculated.

For each of the shunt reactor sizes calculated, all project generators and reactive devices were switched offline while other collector system elements remained in-service. For the SGF reactor size calculation, the EGF generators were also switched offline. A shunt reactor was tested at the project’s collection substation 34.5 kV bus to reduce the MVAR injection at the POI to zero. The size of the shunt reactor is equivalent to the charging current value at unity voltage and the compensation provided is proportional to the voltage effects on the charging current (i.e., for voltages above unity, reactive compensation is greater than the size of the reactor).

Aneden performed the reactive power analysis using the SGF data based on the 25SP DISIS-2021-001 stability study model.

3.2 Results

Per the methodology described above, the shunt size was determined for the EGF prior to calculating the shunt reactor size for the SGF. The shunt size was found to be a 0.6 MVAR reactor for the EGF to reduce the MVAR injection at the POI to zero. Note that the EGF shunt value is for the SGF reactive size determination only and not for sizing the predetermined EGF reactive requirements.

The results from the analysis showed that the SGF needed an approximately 0.1 MVAR shunt reactor at the SGF substation, to reduce the MVAR injection at the POI to zero with the pre-determined shunt for the EGF in-service. The final shunt reactor requirements are shown in Table 3-1. Figure 3-1 illustrates the shunt reactor size needed to reduce the POI MVAR to approximately zero.

The information gathered from the reactive power analysis is provided as information to the Interconnection Customer and Transmission Owner (TO) and/or Transmission Operator (TOP). The applicable reactive power requirements will be further reviewed by the TO and/or TOP.

Table 3-1: Shunt Reactor Size for Reactive Power Analysis

Machine	POI Bus Number	POI Bus Name	Reactor Size (MVAR)
			25SP
GEN-2025-SR27 (SGF)	527482	CHAVES_CNTY3	0.1

Figure 3-1: GEN-2025-SR27 Single Line Diagram (Shunt Sizes)

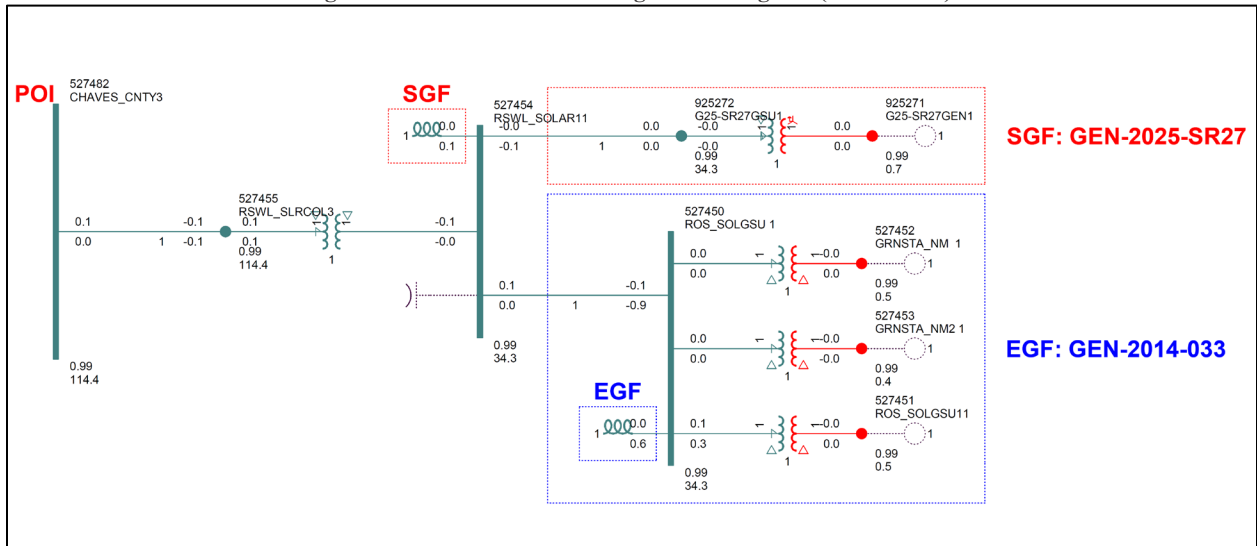

4.0 Short Circuit Analysis

A short circuit study was performed using the 25SP model to determine the maximum available fault current requiring interruption by protective equipment with both the SGF and EGF online for each bus in the relevant subsystem, and the amount of increase in maximum fault current due to the addition of the SGF. The detailed results of the short circuit analysis are provided in Appendix B.

4.1 Methodology

The short circuit analysis included applying a 3-phase fault on buses up to 5 levels away from the 115 kV POI bus. The PSS/E “Automatic Sequence Fault Calculation (ASCC)” fault analysis module was used to calculate the fault current levels in the transmission system with and without the SGF online. The first scenario was studied with both the SGF and EGF in service. In the second scenario the SGF was disconnected while the EGF was online to determine the impact of the SGF.

Aneden created a short circuit model using the 25SP DISIS-2021-001 stability study model by adjusting the SGF short circuit parameters consistent with the submitted data. The adjusted parameters used in the short circuit analysis are shown in Table 4-1 below. No other changes were made to the model.

Table 4-1: Short Circuit Model Parameters*

Parameter	Value by Generator Bus#
	925271
Machine MVA Base	64.26
R (pu)	0.0
X'' (pu)	0.893

*pu values based on Machine MVA Base

4.2 Results

The results of the short circuit analysis compared the 25SP model with the EGF online and SGF not connected to the stability Scenario 2 dispatch model with both the EGF and SGF in service as described in Section 5.1. The GEN-2025-SR27 POI bus (Chaves County 115kV) fault current magnitudes for the comparison cases are provided in Table 4-2 showing a fault current of 7.63 kA with the EGF and SGF online. The addition of the SGF configuration increased the POI bus fault current by 0.23 kA. Table 4-3 shows the maximum fault current magnitudes and fault current increases with the SGF project online.

The maximum fault current calculated within 5 buses of the POI was 32.4 kA for the 25SP model. The maximum contribution to three-phase fault currents due to the addition of the SGF was about 3.1% and 0.23 kA.

Table 4-2: POI Short Circuit Comparison Results

Case	EGF Only Current (kA)	SGF & EGF Current (kA)	kA Change	%Change
25SP	7.40	7.63	0.23	3.1%

Table 4-3: 25SP Short Circuit Comparison Results

Voltage (kV)	Max. Current (EGF & SGF) (kA)	Max kA Change	Max %Change
69	4.2	0.03	0.7%
115	29.8	0.23	3.1%
230	32.4	0.10	2.1%
345	17.1	0.02	0.2%
Max	32.4	0.23	3.1%

5.0 Dynamic Stability Analysis

Aneden performed a dynamic stability analysis to identify the impact of the SGF project. The analysis was performed according to SPP's Disturbance Performance Requirements⁵. The project details are described in Section 2.0 above and the dynamic modeling data is provided in Appendix A. The existing base case issues and simulation plots can be found in Appendix C.

5.1 Methodology and Criteria

The dynamic stability analysis was performed using models developed with the requested 17 x Power Electronics FP4200M operating at 2.96 MW (REGCA1) SGF generating facility configuration included in the models. This stability analysis was performed using Siemens PTI's PSS/E version 34.8.1 software.

Two stability model scenarios were developed using the models from DISIS-2021-001. The first scenario (Scenario 1) was comprised of the SGF online at 100% of the assumed dispatch (SGF = 50.32 MW) while the EGF generator was offline and disconnected.

The second scenario (Scenario 2) was comprised of the SGF at 100% of the assumed dispatch (SGF = 50.32 MW) while the EGF generator picked up the remaining EGF GIA capacity (EGF = 19.68 MW). The study scenarios are shown in Table 3-1.

Table 5-1: Study Scenarios (Generator Dispatch MW)

Scenario	GEN-2014-033 EGF (MW)	GEN-2025-SR27 SGF (MW)	EGF + SGF (MW)
1	0 (Offline)	50.32	50.32
2	19.68	50.32	70

The GEN-2025-SR27 project details were used to create modified stability models for this impact study based on the DISIS-2021-001 stability study models:

- 2025 Summer Peak (25SP),
- 2025 Winter Peak (25WP)

The dynamic model data for the GEN-2025-SR27 project is provided in Appendix A. The power flow models and associated dynamic database were initialized (no-fault test) to confirm that there were no errors in the initial conditions of the system and the dynamic data.

The following system adjustments were made to address existing base case issues that are not attributed to the surplus request:

- The voltage protective relays at buses 766062 & 766065 were disabled to avoid generator tripping due to an instantaneous over voltage spike after fault clearing.
- The PSSE dynamic simulation iterations and acceleration factor were adjusted as needed to resolve PSSE dynamic simulation crashes.

During the fault simulations, the active power (PELEC), reactive power (QELEC), and terminal voltage (ETERM) were monitored for the EGF and SGF and other current and prior queued projects in Group

⁵ SPP Disturbance Performance Requirements:

[https://www.spp.org/documents/28859/spp%20disturbance%20performance%20requirements%20\(twg%20approved\).pdf](https://www.spp.org/documents/28859/spp%20disturbance%20performance%20requirements%20(twg%20approved).pdf)

5. In addition, voltages of five (5) buses away from the POI of the SGF were monitored and plotted. The machine rotor angle for synchronous machines and speed for asynchronous machines within the study areas including 520 (AEPW), 524 (OKGE), 526 (SPS), 534 (SUNC), and 652 (WAPA) were monitored. The voltages of all 100 kV and above buses within the study area were monitored as well.

5.2 Fault Definitions

Aneden developed fault events as required to study the SGF. The new set of faults was simulated using the modified study models. The fault events included three-phase faults and single-line-to-ground stuck breaker faults. Single-line-to-ground faults are approximated by applying a fault impedance to bring the faulted bus positive sequence voltage to 0.6 pu. The simulated faults are listed and described in Table 5-2 below. These contingencies were applied to the modified 25SP and 25WP models.

Table 5-2: Fault Definitions

Fault ID	Planning Event	Fault Descriptions
FLT1000-SB	P4	Stuck Breaker on CHAVES_CNTY3 (527482) 115 kV Bus a. Apply single phase fault at the CHAVES_CNTY3 (527482) 115 kV Bus b. Clear fault after 16 cycles and trip the following elements: b.1.Trip the CHAVES_CNTY3 (527482) 115 kV to PRICE_TAP_3 (527509) 115 kV line CKT 1.
FLT1001-SB	P4	Stuck Breaker on CHAVES_CNTY3 (527482) 115 kV Bus a. Apply single phase fault at the CHAVES_CNTY3 (527482) 115 kV Bus b. Clear fault after 16 cycles and trip the following elements: b.1.Trip the CHAVES_CNTY3 (527482) 115 kV to PRICE_TAP_3 (527509) 115 kV line CKT 1. b.2.Trip the CHAVES_CNTY3 (527482) 115 kV to URTON_3 (527501) 115 kV line CKT 1.
FLT1002-SB	P4	Stuck Breaker on CHAVES_CNTY3 (527482) 115 kV Bus a. Apply single phase fault at the CHAVES_CNTY3 (527482) 115 kV Bus b. Clear fault after 16 cycles and trip the following elements: b.1.Trip the CHAVES_CNTY3 (527482) 115 kV to URTON_3 (527501) 115 kV line CKT 1.
FLT1003-SB	P4	Stuck Breaker on CHAVES_CNTY3 (527482) 115 kV Bus a. Apply single phase fault at the CHAVES_CNTY3 (527482) 115 kV Bus b. Clear fault after 16 cycles and trip the following elements: b.1.Trip the CHAVES_CNTY3 (527482) 115 kV to RSWL_SLRCOL3 (527455) 115 kV line CKT 1. Trip generator(s) on the Bus ROS_SOLGSU11 (527451) 0.6 kV Trip generator(s) on the Bus GRNSTA_NM_1 (527452) 0.6 kV Trip generator(s) on the Bus GRNSTA_NM2 1 (527453) 0.4 kV Trip generator(s) on the Bus G25-SR27GEN1 (925271) 0.66 kV
FLT1004-SB	P4	Stuck Breaker on CHAVES_CNTY3 (527482) 115 kV Bus a. Apply single phase fault at the CHAVES_CNTY3 (527482) 115 kV Bus b. Clear fault after 16 cycles and trip the following elements: b.1.Trip the CHAVES_CNTY3 (527482) 115 kV / CHAVES_CNTY6 (527483) 230 kV / CHAVES_TR1 1 (527478) 13.2 kV XFMR CKT 1.
FLT1005-SB	P4	Stuck Breaker on CHAVES_CNTY3 (527482) 115 kV Bus a. Apply single phase fault at the CHAVES_CNTY3 (527482) 115 kV Bus b. Clear fault after 16 cycles and trip the following elements: b.1.Trip the CHAVES_CNTY3 (527482) 115 kV / CHAVES_CNTY6 (527483) 230 kV / CHAVES_TR1 1 (527478) 13.2 kV XFMR CKT 1. b.2.Trip the CHAVES_CNTY3 (527482) 115 kV to CHVS_SLRCOL3 (527470) 115 kV line CKT 1. Trip generator(s) on the Bus CHVS_SOLAR11 (527461) 0.6 kV Trip generator(s) on the Bus G14-035-GEN1 (583973) 0.6 kV
FLT1006-SB	P4	Stuck Breaker on CHAVES_CNTY3 (527482) 115 kV Bus a. Apply single phase fault at the CHAVES_CNTY3 (527482) 115 kV Bus b. Clear fault after 16 cycles and trip the following elements: b.1.Trip the CHAVES_CNTY3 (527482) 115 kV to CHVS_SLRCOL3 (527470) 115 kV line CKT 1. Trip generator(s) on the Bus CHVS_SOLAR11 (527461) 0.6 kV Trip generator(s) on the Bus G14-035-GEN1 (583973) 0.6 kV

Table 5-2 Continued

Fault ID	Planning Event	Fault Descriptions
FLT1007-SB	P4	Stuck Breaker on CHAVES_CNTY3 (527482) 115 kV Bus a. Apply single phase fault at the CHAVES_CNTY3 (527482) 115 kV Bus b. Clear fault after 16 cycles and trip the following elements: b.1.Trip the CHAVES_CNTY3 (527482) 115 kV to SAMSON 3 (527546) 115 kV line CKT 1.
FLT1008-SB	P4	Stuck Breaker on CHAVES_CNTY3 (527482) 115 kV Bus a. Apply single phase fault at the CHAVES_CNTY3 (527482) 115 kV Bus b. Clear fault after 16 cycles and trip the following elements: b.1.Trip the CHAVES_CNTY3 (527482) 115 kV to SAMSON 3 (527546) 115 kV line CKT 1. b.2.Trip the CHAVES_CNTY3 (527482) 115 kV / CHAVES_CNTY6 (527483) 230 kV / CHAVES_TR2 1 (527479) 13.2 kV XFMR CKT 2.
FLT1009-SB	P4	Stuck Breaker on CHAVES_CNTY3 (527482) 115 kV Bus a. Apply single phase fault at the CHAVES_CNTY3 (527482) 115 kV Bus b. Clear fault after 16 cycles and trip the following elements: b.1.Trip the CHAVES_CNTY3 (527482) 115 kV / CHAVES_CNTY6 (527483) 230 kV / CHAVES_TR2 1 (527479) 13.2 kV XFMR CKT 2.
FLT1010-SB	P4	Stuck Breaker on CHAVES_CNTY6 (527483) 230 kV Bus a. Apply single phase fault at the CHAVES_CNTY6 (527483) 230 kV Bus b. Clear fault after 16 cycles and trip the following elements: b.1.Trip the CHAVES_CNTY6 (527483) 230 kV / CHAVES_CNTY3 (527482) 115 kV / CHAVES_TR1 1 (527478) 13.2 kV XFMR CKT 1.
FLT1011-SB	P4	Stuck Breaker on CHAVES_CNTY6 (527483) 230 kV Bus a. Apply single phase fault at the CHAVES_CNTY6 (527483) 230 kV Bus b. Clear fault after 16 cycles and trip the following elements: b.1.Trip the CHAVES_CNTY6 (527483) 230 kV / CHAVES_CNTY3 (527482) 115 kV / CHAVES_TR1 1 (527478) 13.2 kV XFMR CKT 1. b.2.Trip the CHAVES_CNTY6 (527483) 230 kV to SN_JUAN_TAP6 (524885) 230 kV line CKT 1.
FLT1012-SB	P4	Stuck Breaker on CHAVES_CNTY6 (527483) 230 kV Bus a. Apply single phase fault at the CHAVES_CNTY6 (527483) 230 kV Bus b. Clear fault after 16 cycles and trip the following elements: b.1.Trip the CHAVES_CNTY6 (527483) 230 kV to SN_JUAN_TAP6 (524885) 230 kV line CKT 1.
FLT1013-SB	P4	Stuck Breaker on CHAVES_CNTY6 (527483) 230 kV Bus a. Apply single phase fault at the CHAVES_CNTY6 (527483) 230 kV Bus b. Clear fault after 16 cycles and trip the following elements: b.1.Trip the CHAVES_CNTY6 (527483) 230 kV to EDDY_NORTH 6 (527799) 230 kV line CKT 1.
FLT1014-SB	P4	Stuck Breaker on CHAVES_CNTY6 (527483) 230 kV Bus a. Apply single phase fault at the CHAVES_CNTY6 (527483) 230 kV Bus b. Clear fault after 16 cycles and trip the following elements: b.1.Trip the CHAVES_CNTY6 (527483) 230 kV to EDDY_NORTH 6 (527799) 230 kV line CKT 1. b.2.Trip the CHAVES_CNTY6 (527483) 230 kV / CHAVES_CNTY3 (527482) 115 kV / CHAVES_TR2 1 (527479) 13.2 kV XFMR CKT 2.
FLT1015-SB	P4	Stuck Breaker on CHAVES_CNTY6 (527483) 230 kV Bus a. Apply single phase fault at the CHAVES_CNTY6 (527483) 230 kV Bus b. Clear fault after 16 cycles and trip the following elements: b.1.Trip the CHAVES_CNTY6 (527483) 230 kV / CHAVES_CNTY3 (527482) 115 kV / CHAVES_TR2 1 (527479) 13.2 kV XFMR CKT 2.
FLT1016-SB	P4	Stuck Breaker on SN_JUAN_TAP6 (524885) 230 kV Bus a. Apply single phase fault at the SN_JUAN_TAP6 (524885) 230 kV Bus b. Clear fault after 16 cycles and trip the following elements: b.1.Trip bus SN_JUAN_TAP6 (524885) 230 kV. Trip generator(s) on the Bus SNJN-WTGA1 1 (524890) 0.6 kV Trip generator(s) on the Bus SNJN-WTG21 1 (524896) 0.6 kV
FLT1017-SB	P4	Stuck Breaker on EDDY_NORTH 6 (527799) 230 kV Bus a. Apply single phase fault at the EDDY_NORTH 6 (527799) 230 kV Bus b. Clear fault after 16 cycles and trip the following elements: b.1.Trip the EDDY_NORTH 6 (527799) 230 kV to CHAVES_CNTY6 (527483) 230 kV line CKT 1.
FLT1018-SB	P4	Stuck Breaker on EDDY_NORTH 6 (527799) 230 kV Bus a. Apply single phase fault at the EDDY_NORTH 6 (527799) 230 kV Bus b. Clear fault after 16 cycles and trip the following elements: b.1.Trip the EDDY_NORTH 6 (527799) 230 kV / EDDY_CNTY 7 (527802) 345 kV / EDDY_TR 1 (527796) 13.2 kV XFMR CKT 1.

Table 5-2 Continued

Fault ID	Planning Event	Fault Descriptions
FLT1019-SB	P4	Stuck Breaker on EDDY_NORTH 6 (527799) 230 kV Bus a. Apply single phase fault at the EDDY_NORTH 6 (527799) 230 kV Bus b. Clear fault after 16 cycles and trip the following elements: b.1.Trip the EDDY_NORTH 6 (527799) 230 kV / EDDY_STH 3 (527793) 115 kV / EDDY_TR3 1 (527795) 13.2 kV XFMR CKT 2.
FLT1020-SB	P4	Stuck Breaker on EDDY_NORTH 6 (527799) 230 kV Bus a. Apply single phase fault at the EDDY_NORTH 6 (527799) 230 kV Bus b. Clear fault after 16 cycles and trip the following elements: b.1.Trip the EDDY_NORTH 6 (527799) 230 kV / EDDY_SVC 1 (527790) 8.5 kV XFMR CKT 1.
FLT1021-SB	P4	Stuck Breaker on EDDY_NORTH 6 (527799) 230 kV Bus a. Apply single phase fault at the EDDY_NORTH 6 (527799) 230 kV Bus b. Clear fault after 16 cycles and trip the following elements: b.1.Trip the EDDY_NORTH 6 (527799) 230 kV to CUNNIGHM N 6 (527865) 230 kV line CKT 1.
FLT1022-SB	P4	Stuck Breaker on EDDY_NORTH 6 (527799) 230 kV Bus a. Apply single phase fault at the EDDY_NORTH 6 (527799) 230 kV Bus b. Clear fault after 16 cycles and trip the following elements: b.1.Trip the EDDY_NORTH 6 (527799) 230 kV / EDDY_NTH 3 (527798) 115 kV / EDDY_TR2 1 (527797) 13.2 kV XFMR CKT 1.
FLT1023-SB	P4	Stuck Breaker on EDDY_NORTH 6 (527799) 230 kV Bus a. Apply single phase fault at the EDDY_NORTH 6 (527799) 230 kV Bus b. Clear fault after 16 cycles and trip the following elements: b.1.Trip the EDDY_NORTH 6 (527799) 230 kV to 7-RIVERS 6 (528095) 230 kV line CKT 1.
FLT1024-SB	P4	Stuck Breaker on EDDY_CNTY 7 (527802) 345 kV Bus a. Apply single phase fault at the EDDY_CNTY 7 (527802) 345 kV Bus b. Clear fault after 16 cycles and trip the following elements: b.1.Trip bus EDDY_CNTY 7 (527802) 345 kV.
FLT1025-SB	P4	Stuck Breaker on EDDY_STH 3 (527793) 115 kV Bus a. Apply single phase fault at the EDDY_STH 3 (527793) 115 kV Bus b. Clear fault after 16 cycles and trip the following elements: b.1.Trip bus EDDY_STH 3 (527793) 115 kV.
FLT1026-SB	P4	Stuck Breaker on EDDY_NTH 3 (527798) 115 kV Bus a. Apply single phase fault at the EDDY_NTH 3 (527798) 115 kV Bus b. Clear fault after 16 cycles and trip the following elements: b.1.Trip bus EDDY_NTH 3 (527798) 115 kV.
FLT1027-SB	P4	Stuck Breaker on SAMSON 3 (527546) 115 kV Bus a. Apply single phase fault at the SAMSON 3 (527546) 115 kV Bus b. Clear fault after 16 cycles and trip the following elements: b.1.Trip bus SAMSON 3 (527546) 115 kV.
FLT1028-SB	P4	Stuck Breaker on PRICE_TAP 3 (527509) 115 kV Bus a. Apply single phase fault at the PRICE_TAP 3 (527509) 115 kV Bus b. Clear fault after 16 cycles and trip the following elements: b.1.Trip bus PRICE_TAP 3 (527509) 115 kV.
FLT1029-SB	P4	Stuck Breaker on URTON 3 (527501) 115 kV Bus a. Apply single phase fault at the URTON 3 (527501) 115 kV Bus b. Clear fault after 16 cycles and trip the following elements: b.1.Trip bus URTON 3 (527501) 115 kV.
FLT9000-3PH	P1	3 Phase fault on CHAVES_CNTY3 (527482) 115 kV to RSWL_SLRCOL3 (527455) 115 kV line CKT 1, near CHAVES_CNTY3 (527482) 115 kV. a. Apply fault at the CHAVES_CNTY3 (527482) 115 kV Bus. b. Clear fault after 7 cycles by tripping the faulted line. Trip generator(s) on the Bus ROS_SOLGSU11 (527451) 0.6 kV Trip generator(s) on the Bus GRNSTA_NM 1 (527452) 0.6 kV Trip generator(s) on the Bus GRNSTA_NM2 1 (527453) 0.4 kV Trip generator(s) on the Bus G25-SR27GEN1 (925271) 0.66 kV c. Wait 20 cycles, and then re-close the line in (b) back into the fault. d. Leave Fault on for 7 cycles, then trip the line in (b) and remove fault.

Table 5-2 Continued

Fault ID	Planning Event	Fault Descriptions
FLT9001-3PH	P1	3 Phase fault on CHAVES_CNTY3 (527482) 115 kV to CHVS_SLRCOL3 (527470) 115 kV line CKT 1, near CHAVES_CNTY3 (527482) 115 kV. a. Apply fault at the CHAVES_CNTY3 (527482) 115 kV Bus. b. Clear fault after 7 cycles by tripping the faulted line. Trip generator(s) on the Bus CHVS_SOLAR11 (527461) 0.6 kV Trip generator(s) on the Bus G14-035-GEN1 (583973) 0.6 kV c. Wait 20 cycles, and then re-close the line in (b) back into the fault. d. Leave Fault on for 7 cycles, then trip the line in (b) and remove fault.
FLT9002-3PH	P1	3 Phase fault on CHAVES_CNTY3 (527482) 115 kV / CHAVES_CNTY6 (527483) 230 kV / CHAVES_TR2 1 (527479) 13.2 kV XFMR CKT 2, near CHAVES_CNTY3 (527482) 115 kV. a. Apply fault at the CHAVES_CNTY3 (527482) 115 kV Bus. b. Clear fault after 7 cycles by tripping the faulted line.
FLT9003-3PH	P1	3 Phase fault on CHAVES_CNTY3 (527482) 115 kV to SAMSON 3 (527546) 115 kV line CKT 1, near CHAVES_CNTY3 (527482) 115 kV. a. Apply fault at the CHAVES_CNTY3 (527482) 115 kV Bus. b. Clear fault after 7 cycles by tripping the faulted line. c. Wait 20 cycles, and then re-close the line in (b) back into the fault. d. Leave Fault on for 7 cycles, then trip the line in (b) and remove fault.
FLT9004-3PH	P1	3 Phase fault on SAMSON 3 (527546) 115 kV to CHAVES_CNTY3 (527482) 115 kV line CKT 1, near SAMSON 3 (527546) 115 kV. a. Apply fault at the SAMSON 3 (527546) 115 kV Bus. b. Clear fault after 7 cycles by tripping the faulted line. c. Wait 20 cycles, and then re-close the line in (b) back into the fault. d. Leave Fault on for 7 cycles, then trip the line in (b) and remove fault.
FLT9005-3PH	P1	3 Phase fault on CHAVES_CNTY3 (527482) 115 kV to PRICE_TAP 3 (527509) 115 kV line CKT 1, near CHAVES_CNTY3 (527482) 115 kV. a. Apply fault at the CHAVES_CNTY3 (527482) 115 kV Bus. b. Clear fault after 7 cycles by tripping the faulted line. c. Wait 20 cycles, and then re-close the line in (b) back into the fault. d. Leave Fault on for 7 cycles, then trip the line in (b) and remove fault.
FLT9006-3PH	P1	3 Phase fault on PRICE_TAP 3 (527509) 115 kV to CHAVES_CNTY3 (527482) 115 kV line CKT 1, near PRICE_TAP 3 (527509) 115 kV. a. Apply fault at the PRICE_TAP 3 (527509) 115 kV Bus. b. Clear fault after 7 cycles by tripping the faulted line. c. Wait 20 cycles, and then re-close the line in (b) back into the fault. d. Leave Fault on for 7 cycles, then trip the line in (b) and remove fault.
FLT9007-3PH	P1	3 Phase fault on CHAVES_CNTY3 (527482) 115 kV to URTON 3 (527501) 115 kV line CKT 1, near CHAVES_CNTY3 (527482) 115 kV. a. Apply fault at the CHAVES_CNTY3 (527482) 115 kV Bus. b. Clear fault after 7 cycles by tripping the faulted line. c. Wait 20 cycles, and then re-close the line in (b) back into the fault. d. Leave Fault on for 7 cycles, then trip the line in (b) and remove fault.
FLT9008-3PH	P1	3 Phase fault on URTON 3 (527501) 115 kV to CHAVES_CNTY3 (527482) 115 kV line CKT 1, near URTON 3 (527501) 115 kV. a. Apply fault at the URTON 3 (527501) 115 kV Bus. b. Clear fault after 7 cycles by tripping the faulted line. c. Wait 20 cycles, and then re-close the line in (b) back into the fault. d. Leave Fault on for 7 cycles, then trip the line in (b) and remove fault.
FLT9009-3PH	P1	3 Phase fault on CHAVES_CNTY6 (527483) 230 kV to SN_JUAN_TAP6 (524885) 230 kV line CKT 1, near CHAVES_CNTY6 (527483) 230 kV. a. Apply fault at the CHAVES_CNTY6 (527483) 230 kV Bus. b. Clear fault after 7 cycles by tripping the faulted line. c. Wait 20 cycles, and then re-close the line in (b) back into the fault. d. Leave Fault on for 7 cycles, then trip the line in (b) and remove fault.
FLT9010-3PH	P1	3 Phase fault on SN_JUAN_TAP6 (524885) 230 kV to CHAVES_CNTY6 (527483) 230 kV line CKT 1, near SN_JUAN_TAP6 (524885) 230 kV. a. Apply fault at the SN_JUAN_TAP6 (524885) 230 kV Bus. b. Clear fault after 7 cycles by tripping the faulted line. c. Wait 20 cycles, and then re-close the line in (b) back into the fault. d. Leave Fault on for 7 cycles, then trip the line in (b) and remove fault.

Table 5-2 Continued

Fault ID	Planning Event	Fault Descriptions
FLT9011-3PH	P1	3 Phase fault on SN_JUAN_TAP6 (524885) 230 kV to OASIS 6 (524875) 230 kV line CKT 1, near SN_JUAN_TAP6 (524885) 230 kV. a. Apply fault at the SN_JUAN_TAP6 (524885) 230 kV Bus. b. Clear fault after 7 cycles by tripping the faulted line. c. Wait 20 cycles, and then re-close the line in (b) back into the fault. d. Leave Fault on for 7 cycles, then trip the line in (b) and remove fault.
FLT9012-3PH	P1	3 Phase fault on OASIS 6 (524875) 230 kV to SN_JUAN_TAP6 (524885) 230 kV line CKT 1, near OASIS 6 (524875) 230 kV. a. Apply fault at the OASIS 6 (524875) 230 kV Bus. b. Clear fault after 7 cycles by tripping the faulted line. c. Wait 20 cycles, and then re-close the line in (b) back into the fault. d. Leave Fault on for 7 cycles, then trip the line in (b) and remove fault.
FLT9013-3PH	P1	3 Phase fault on SN_JUAN_TAP6 (524885) 230 kV to SN_JUAN_WND6 (524889) 230 kV line CKT 1, near SN_JUAN_TAP6 (524885) 230 kV. a. Apply fault at the SN_JUAN_TAP6 (524885) 230 kV Bus. b. Clear fault after 7 cycles by tripping the faulted line. Trip generator(s) on the Bus SNJN-WTGA1 1 (524890) 0.6 kV Trip generator(s) on the Bus SNJN-WTG21 1 (524896) 0.6 kV c. Wait 20 cycles, and then re-close the line in (b) back into the fault. d. Leave Fault on for 7 cycles, then trip the line in (b) and remove fault.
FLT9014-3PH	P1	3 Phase fault on SN_JUAN_WND6 (524889) 230 kV to SN_JUAN_TAP6 (524885) 230 kV line CKT 1, near SN_JUAN_WND6 (524889) 230 kV. a. Apply fault at the SN_JUAN_WND6 (524889) 230 kV Bus. b. Clear fault after 7 cycles by tripping the faulted line. Trip generator(s) on the Bus SNJN-WTGA1 1 (524890) 0.6 kV Trip generator(s) on the Bus SNJN-WTG21 1 (524896) 0.6 kV c. Wait 20 cycles, and then re-close the line in (b) back into the fault. d. Leave Fault on for 7 cycles, then trip the line in (b) and remove fault.
FLT9015-3PH	P1	3 Phase fault on OASIS 6 (524875) 230 kV to PLSNT_HILL 6 (524770) 230 kV line CKT 1, near OASIS 6 (524875) 230 kV. a. Apply fault at the OASIS 6 (524875) 230 kV Bus. b. Clear fault after 7 cycles by tripping the faulted line. c. Wait 20 cycles, and then re-close the line in (b) back into the fault. d. Leave Fault on for 7 cycles, then trip the line in (b) and remove fault.
FLT9016-3PH	P1	3 Phase fault on OASIS 6 (524875) 230 kV to ROOSEVELT 6 (524909) 230 kV line CKT 1, near OASIS 6 (524875) 230 kV. a. Apply fault at the OASIS 6 (524875) 230 kV Bus. b. Clear fault after 7 cycles by tripping the faulted line. c. Wait 20 cycles, and then re-close the line in (b) back into the fault. d. Leave Fault on for 7 cycles, then trip the line in (b) and remove fault.
FLT9017-3PH	P1	3 Phase fault on OASIS 6 (524875) 230 kV / OASIS 3 (524874) 115 kV / OASIS_TR1 1 (524872) 13.2 kV XFMR CKT 1, near OASIS 6 (524875) 230 kV. a. Apply fault at the OASIS 6 (524875) 230 kV Bus. b. Clear fault after 7 cycles by tripping the faulted line.
FLT9018-3PH	P1	3 Phase fault on OASIS 6 (524875) 230 kV to GEN-2020-062 (764890) 230 kV line CKT 1, near OASIS 6 (524875) 230 kV. a. Apply fault at the OASIS 6 (524875) 230 kV Bus. b. Clear fault after 7 cycles by tripping the faulted line. Trip generator(s) on the Bus G20-062-GEN1 (764891) 0.6 kV Trip generator(s) on the Bus G20-062-GEN2 (764894) 0.6 kV c. Wait 20 cycles, and then re-close the line in (b) back into the fault. d. Leave Fault on for 7 cycles, then trip the line in (b) and remove fault.
FLT9019-3PH	P1	3 Phase fault on CHAVES_CNTY6 (527483) 230 kV to EDDY_NORTH 6 (527799) 230 kV line CKT 1, near CHAVES_CNTY6 (527483) 230 kV. a. Apply fault at the CHAVES_CNTY6 (527483) 230 kV Bus. b. Clear fault after 7 cycles by tripping the faulted line. c. Wait 20 cycles, and then re-close the line in (b) back into the fault. d. Leave Fault on for 7 cycles, then trip the line in (b) and remove fault.

Table 5-2 Continued

Fault ID	Planning Event	Fault Descriptions
FLT9020-3PH	P1	3 Phase fault on EDDY_NORTH 6 (527799) 230 kV to CHAVES_CNTY6 (527483) 230 kV line CKT 1, near EDDY_NORTH 6 (527799) 230 kV. a. Apply fault at the EDDY_NORTH 6 (527799) 230 kV Bus. b. Clear fault after 7 cycles by tripping the faulted line. c. Wait 20 cycles, and then re-close the line in (b) back into the fault. d. Leave Fault on for 7 cycles, then trip the line in (b) and remove fault.
FLT9021-3PH	P1	3 Phase fault on EDDY_NORTH 6 (527799) 230 kV / EDDY_CNTY 7 (527802) 345 kV / EDDY_TR 1 (527796) 13.2 kV XFMR CKT 1, near EDDY_NORTH 6 (527799) 230 kV. a. Apply fault at the EDDY_NORTH 6 (527799) 230 kV Bus. b. Clear fault after 7 cycles by tripping the faulted line.
FLT9022-3PH	P1	3 Phase fault on EDDY_CNTY 7 (527802) 345 kV to CROSSROADS 7 (527656) 345 kV line CKT 1, near EDDY_CNTY 7 (527802) 345 kV. a. Apply fault at the EDDY_CNTY 7 (527802) 345 kV Bus. b. Clear fault after 6 cycles by tripping the faulted line. c. Wait 20 cycles, and then re-close the line in (b) back into the fault. d. Leave Fault on for 6 cycles, then trip the line in (b) and remove fault.
FLT9023-3PH	P1	3 Phase fault on CROSSROADS 7 (527656) 345 kV to EDDY_CNTY 7 (527802) 345 kV line CKT 1, near CROSSROADS 7 (527656) 345 kV. a. Apply fault at the CROSSROADS 7 (527656) 345 kV Bus. b. Clear fault after 6 cycles by tripping the faulted line. c. Wait 20 cycles, and then re-close the line in (b) back into the fault. d. Leave Fault on for 6 cycles, then trip the line in (b) and remove fault.
FLT9024-3PH	P1	3 Phase fault on CROSSROADS 7 (527656) 345 kV to RSVLT_CC_E 7 (527655) 345 kV line CKT 1, near CROSSROADS 7 (527656) 345 kV. a. Apply fault at the CROSSROADS 7 (527656) 345 kV Bus. b. Clear fault after 6 cycles by tripping the faulted line. Trip generator(s) on the Bus RSVLT_GEN1 1 (527651) 0.7 kV Trip generator(s) on the Bus RSVLT_GEN2 1 (527652) 0.7 kV Trip generator(s) on the Bus MILO_WIND 1 (527653) 0.7 kV c. Wait 20 cycles, and then re-close the line in (b) back into the fault. d. Leave Fault on for 6 cycles, then trip the line in (b) and remove fault.
FLT9025-3PH	P1	3 Phase fault on CROSSROADS 7 (527656) 345 kV to TOLK 7 (525549) 345 kV line CKT 1, near CROSSROADS 7 (527656) 345 kV. a. Apply fault at the CROSSROADS 7 (527656) 345 kV Bus. b. Clear fault after 6 cycles by tripping the faulted line. c. Wait 20 cycles, and then re-close the line in (b) back into the fault. d. Leave Fault on for 6 cycles, then trip the line in (b) and remove fault.
FLT9026-3PH	P1	3 Phase fault on CROSSROADS 7 (527656) 345 kV to SAGA_SCOL 7 (527610) 345 kV line CKT 1, near CROSSROADS 7 (527656) 345 kV. a. Apply fault at the CROSSROADS 7 (527656) 345 kV Bus. b. Clear fault after 6 cycles by tripping the faulted line. Trip generator(s) on the Bus SAGSFT3_2.21 (527605) 0.7 kV Trip generator(s) on the Bus SAGSFT4_2.21 (527607) 0.7 kV Trip generator(s) on the Bus SAGSFT1_2.21 (527614) 0.7 kV Trip generator(s) on the Bus SAGSFT1_2.01 (527615) 0.7 kV Trip generator(s) on the Bus SAGSFT2_2.21 (527617) 0.7 kV Trip generator(s) on the Bus SAGSFT2_2.01 (527618) 0.7 kV c. Wait 20 cycles, and then re-close the line in (b) back into the fault. d. Leave Fault on for 6 cycles, then trip the line in (b) and remove fault.
FLT9027-3PH	P1	3 Phase fault on CROSSROADS 7 (527656) 345 kV to HOBBS_INT 7 (527896) 345 kV line CKT 1, near CROSSROADS 7 (527656) 345 kV. a. Apply fault at the CROSSROADS 7 (527656) 345 kV Bus. b. Clear fault after 6 cycles by tripping the faulted line. c. Wait 20 cycles, and then re-close the line in (b) back into the fault. d. Leave Fault on for 6 cycles, then trip the line in (b) and remove fault.
FLT9028-3PH	P1	3 Phase fault on EDDY_CNTY 7 (527802) 345 kV to KIOWA 7 (527965) 345 kV line CKT 1, near EDDY_CNTY 7 (527802) 345 kV. a. Apply fault at the EDDY_CNTY 7 (527802) 345 kV Bus. b. Clear fault after 6 cycles by tripping the faulted line. c. Wait 20 cycles, and then re-close the line in (b) back into the fault. d. Leave Fault on for 6 cycles, then trip the line in (b) and remove fault.

Table 5-2 Continued

Fault ID	Planning Event	Fault Descriptions
FLT9029-3PH	P1	3 Phase fault on KIOWA 7 (527965) 345 kV to EDDY_CNTY 7 (527802) 345 kV line CKT 1, near KIOWA 7 (527965) 345 kV. a. Apply fault at the KIOWA 7 (527965) 345 kV Bus. b. Clear fault after 6 cycles by tripping the faulted line. c. Wait 20 cycles, and then re-close the line in (b) back into the fault. d. Leave Fault on for 6 cycles, then trip the line in (b) and remove fault.
FLT9030-3PH	P1	3 Phase fault on KIOWA 7 (527965) 345 kV to RDRUNNER 7 (528027) 345 kV line CKT 1, near KIOWA 7 (527965) 345 kV. a. Apply fault at the KIOWA 7 (527965) 345 kV Bus. b. Clear fault after 6 cycles by tripping the faulted line. c. Wait 20 cycles, and then re-close the line in (b) back into the fault. d. Leave Fault on for 6 cycles, then trip the line in (b) and remove fault.
FLT9031-3PH	P1	3 Phase fault on KIOWA 7 (527965) 345 kV to HOBBS_INT 7 (527896) 345 kV line CKT 1, near KIOWA 7 (527965) 345 kV. a. Apply fault at the KIOWA 7 (527965) 345 kV Bus. b. Clear fault after 6 cycles by tripping the faulted line. c. Wait 20 cycles, and then re-close the line in (b) back into the fault. d. Leave Fault on for 6 cycles, then trip the line in (b) and remove fault.
FLT9032-3PH	P1	3 Phase fault on KIOWA 7 (527965) 345 kV to N_LOVING 7 (528185) 345 kV line CKT 1, near KIOWA 7 (527965) 345 kV. a. Apply fault at the KIOWA 7 (527965) 345 kV Bus. b. Clear fault after 6 cycles by tripping the faulted line. c. Wait 20 cycles, and then re-close the line in (b) back into the fault. d. Leave Fault on for 6 cycles, then trip the line in (b) and remove fault.
FLT9033-3PH	P1	3 Phase fault on KIOWA 7 (527965) 345 kV / KIOWA 3 (527966) 115 kV / KIOWA_TR1 1 (527964) 13.2 kV XFMR CKT 1, near KIOWA 7 (527965) 345 kV. a. Apply fault at the KIOWA 7 (527965) 345 kV Bus. b. Clear fault after 6 cycles by tripping the faulted line.
FLT9034-3PH	P1	3 Phase fault on EDDY_NORTH 6 (527799) 230 kV / EDDY_NTH 3 (527798) 115 kV / EDDY_TR2 1 (527797) 13.2 kV XFMR CKT 1, near EDDY_NORTH 6 (527799) 230 kV. a. Apply fault at the EDDY_NORTH 6 (527799) 230 kV Bus. b. Clear fault after 7 cycles by tripping the faulted line.
FLT9035-3PH	P1	3 Phase fault on EDDY_NORTH 6 (527799) 230 kV / EDDY_STH 3 (527793) 115 kV / EDDY_TR3 1 (527795) 13.2 kV XFMR CKT 2, near EDDY_NORTH 6 (527799) 230 kV. a. Apply fault at the EDDY_NORTH 6 (527799) 230 kV Bus. b. Clear fault after 7 cycles by tripping the faulted line.
FLT9036-3PH	P1	3 Phase fault on EDDY_NTH 3 (527798) 115 kV to CV-8_MILE 3 (527809) 115 kV line CKT 1, near EDDY_NTH 3 (527798) 115 kV. a. Apply fault at the EDDY_NTH 3 (527798) 115 kV Bus. b. Clear fault after 7 cycles by tripping the faulted line. c. Wait 20 cycles, and then re-close the line in (b) back into the fault. d. Leave Fault on for 7 cycles, then trip the line in (b) and remove fault.
FLT9037-3PH	P1	3 Phase fault on CV-8_MILE 3 (527809) 115 kV to EDDY_NTH 3 (527798) 115 kV line CKT 1, near CV-8_MILE 3 (527809) 115 kV. a. Apply fault at the CV-8_MILE 3 (527809) 115 kV Bus. b. Clear fault after 7 cycles by tripping the faulted line. c. Wait 20 cycles, and then re-close the line in (b) back into the fault. d. Leave Fault on for 7 cycles, then trip the line in (b) and remove fault.
FLT9038-3PH	P1	3 Phase fault on CV-8_MILE 3 (527809) 115 kV to CV-TURKYTRK3 (527822) 115 kV line CKT 1, near CV-8_MILE 3 (527809) 115 kV. a. Apply fault at the CV-8_MILE 3 (527809) 115 kV Bus. b. Clear fault after 7 cycles by tripping the faulted line. c. Wait 20 cycles, and then re-close the line in (b) back into the fault. d. Leave Fault on for 7 cycles, then trip the line in (b) and remove fault.
FLT9039-3PH	P1	3 Phase fault on CV-8_MILE 3 (527809) 115 kV to CV-8_MILE 2 (527808) 67 kV XFMR CKT 1, near CV-8_MILE 3 (527809) 115 kV. a. Apply fault at the CV-8_MILE 3 (527809) 115 kV Bus. b. Clear fault after 7 cycles by tripping the faulted line.

Table 5-2 Continued

Fault ID	Planning Event	Fault Descriptions
FLT9040-3PH	P1	3 Phase fault on EDDY_NTH 3 (527798) 115 kV to EAGLE_CREEK3 (527711) 115 kV line CKT 1, near EDDY_NTH 3 (527798) 115 kV. a. Apply fault at the EDDY_NTH 3 (527798) 115 kV Bus. b. Clear fault after 7 cycles by tripping the faulted line. c. Wait 20 cycles, and then re-close the line in (b) back into the fault. d. Leave Fault on for 7 cycles, then trip the line in (b) and remove fault.
FLT9041-3PH	P1	3 Phase fault on EAGLE_CREEK3 (527711) 115 kV to EDDY_NTH 3 (527798) 115 kV line CKT 1, near EAGLE_CREEK3 (527711) 115 kV. a. Apply fault at the EAGLE_CREEK3 (527711) 115 kV Bus. b. Clear fault after 7 cycles by tripping the faulted line. c. Wait 20 cycles, and then re-close the line in (b) back into the fault. d. Leave Fault on for 7 cycles, then trip the line in (b) and remove fault.
FLT9042-3PH	P1	3 Phase fault on EAGLE_CREEK3 (527711) 115 kV / EAGLE_CREEK2 (527710) 69 kV / EGCREEK_TR11 (527709) 13.2 kV XFMR CKT 1, near EAGLE_CREEK3 (527711) 115 kV. a. Apply fault at the EAGLE_CREEK3 (527711) 115 kV Bus. b. Clear fault after 7 cycles by tripping the faulted line.
FLT9043-3PH	P1	3 Phase fault on EAGLE_CREEK3 (527711) 115 kV to NAVAJO_5TP 3 (527736) 115 kV line CKT 1, near EAGLE_CREEK3 (527711) 115 kV. a. Apply fault at the EAGLE_CREEK3 (527711) 115 kV Bus. b. Clear fault after 7 cycles by tripping the faulted line. c. Wait 20 cycles, and then re-close the line in (b) back into the fault. d. Leave Fault on for 7 cycles, then trip the line in (b) and remove fault.
FLT9044-3PH	P1	3 Phase fault on EAGLE_CREEK3 (527711) 115 kV to NAVAJO_2TP 3 (527715) 115 kV line CKT 1, near EAGLE_CREEK3 (527711) 115 kV. a. Apply fault at the EAGLE_CREEK3 (527711) 115 kV Bus. b. Clear fault after 7 cycles by tripping the faulted line. c. Wait 20 cycles, and then re-close the line in (b) back into the fault. d. Leave Fault on for 7 cycles, then trip the line in (b) and remove fault.
FLT9045-3PH	P1	3 Phase fault on EAGLE_CREEK3 (527711) 115 kV to ARTESIA 3 (527707) 115 kV line CKT 1, near EAGLE_CREEK3 (527711) 115 kV. a. Apply fault at the EAGLE_CREEK3 (527711) 115 kV Bus. b. Clear fault after 7 cycles by tripping the faulted line. c. Wait 20 cycles, and then re-close the line in (b) back into the fault. d. Leave Fault on for 7 cycles, then trip the line in (b) and remove fault.
FLT9046-3PH	P1	3 Phase fault on EAGLE_CREEK3 (527711) 115 kV to ARTSA_CC_TP3 (527777) 115 kV line CKT 1, near EAGLE_CREEK3 (527711) 115 kV. a. Apply fault at the EAGLE_CREEK3 (527711) 115 kV Bus. b. Clear fault after 7 cycles by tripping the faulted line. c. Wait 20 cycles, and then re-close the line in (b) back into the fault. d. Leave Fault on for 7 cycles, then trip the line in (b) and remove fault.
FLT9047-3PH	P1	3 Phase fault on EAGLE_CREEK3 (527711) 115 kV to 7-RIVERS 3 (528094) 115 kV line CKT 1, near EAGLE_CREEK3 (527711) 115 kV. a. Apply fault at the EAGLE_CREEK3 (527711) 115 kV Bus. b. Clear fault after 7 cycles by tripping the faulted line. c. Wait 20 cycles, and then re-close the line in (b) back into the fault. d. Leave Fault on for 7 cycles, then trip the line in (b) and remove fault.
FLT9048-3PH	P1	3 Phase fault on EDDY_NTH 3 (527798) 115 kV to TWEEDY 3 (527597) 115 kV line CKT 1, near EDDY_NTH 3 (527798) 115 kV. a. Apply fault at the EDDY_NTH 3 (527798) 115 kV Bus. b. Clear fault after 7 cycles by tripping the faulted line. c. Wait 20 cycles, and then re-close the line in (b) back into the fault. d. Leave Fault on for 7 cycles, then trip the line in (b) and remove fault.
FLT9049-3PH	P1	3 Phase fault on TWEEDY 3 (527597) 115 kV to EDDY_NTH 3 (527798) 115 kV line CKT 1, near TWEEDY 3 (527597) 115 kV. a. Apply fault at the TWEEDY 3 (527597) 115 kV Bus. b. Clear fault after 7 cycles by tripping the faulted line. c. Wait 20 cycles, and then re-close the line in (b) back into the fault. d. Leave Fault on for 7 cycles, then trip the line in (b) and remove fault.

Table 5-2 Continued

Fault ID	Planning Event	Fault Descriptions
FLT9050-3PH	P1	3 Phase fault on EDDY_STH 3 (527793) 115 kV to CV-DAYTON +3 (527821) 115 kV line CKT 1, near EDDY_STH 3 (527793) 115 kV. a. Apply fault at the EDDY_STH 3 (527793) 115 kV Bus. b. Clear fault after 7 cycles by tripping the faulted line. c. Wait 20 cycles, and then re-close the line in (b) back into the fault. d. Leave Fault on for 7 cycles, then trip the line in (b) and remove fault.
FLT9051-3PH	P1	3 Phase fault on CV-DAYTON +3 (527821) 115 kV to EDDY_STH 3 (527793) 115 kV line CKT 1, near CV-DAYTON +3 (527821) 115 kV. a. Apply fault at the CV-DAYTON +3 (527821) 115 kV Bus. b. Clear fault after 7 cycles by tripping the faulted line. c. Wait 20 cycles, and then re-close the line in (b) back into the fault. d. Leave Fault on for 7 cycles, then trip the line in (b) and remove fault.
FLT9052-3PH	P1	3 Phase fault on CV-DAYTON +3 (527821) 115 kV to ATOKA 3 (527786) 115 kV line CKT 1, near CV-DAYTON +3 (527821) 115 kV. a. Apply fault at the CV-DAYTON +3 (527821) 115 kV Bus. b. Clear fault after 7 cycles by tripping the faulted line. c. Wait 20 cycles, and then re-close the line in (b) back into the fault. d. Leave Fault on for 7 cycles, then trip the line in (b) and remove fault.
FLT9053-3PH	P1	3 Phase fault on EDDY_STH 3 (527793) 115 kV to PECOS 3 (528178) 115 kV line CKT 1, near EDDY_STH 3 (527793) 115 kV. a. Apply fault at the EDDY_STH 3 (527793) 115 kV Bus. b. Clear fault after 7 cycles by tripping the faulted line. c. Wait 20 cycles, and then re-close the line in (b) back into the fault. d. Leave Fault on for 7 cycles, then trip the line in (b) and remove fault.
FLT9054-3PH	P1	3 Phase fault on PECOS 3 (528178) 115 kV to EDDY_STH 3 (527793) 115 kV line CKT 1, near PECOS 3 (528178) 115 kV. a. Apply fault at the PECOS 3 (528178) 115 kV Bus. b. Clear fault after 7 cycles by tripping the faulted line. c. Wait 20 cycles, and then re-close the line in (b) back into the fault. d. Leave Fault on for 7 cycles, then trip the line in (b) and remove fault.
FLT9055-3PH	P1	3 Phase fault on PECOS 3 (528178) 115 kV to N_CANAL 3 (528137) 115 kV line CKT 1, near PECOS 3 (528178) 115 kV. a. Apply fault at the PECOS 3 (528178) 115 kV Bus. b. Clear fault after 7 cycles by tripping the faulted line. c. Wait 20 cycles, and then re-close the line in (b) back into the fault. d. Leave Fault on for 7 cycles, then trip the line in (b) and remove fault.
FLT9056-3PH	P1	3 Phase fault on PECOS 3 (528178) 115 kV to OCOTILLO 3 (528132) 115 kV line CKT 1, near PECOS 3 (528178) 115 kV. a. Apply fault at the PECOS 3 (528178) 115 kV Bus. b. Clear fault after 7 cycles by tripping the faulted line. c. Wait 20 cycles, and then re-close the line in (b) back into the fault. d. Leave Fault on for 7 cycles, then trip the line in (b) and remove fault.
FLT9057-3PH	P1	3 Phase fault on PECOS 3 (528178) 115 kV to HOPI_SUB 3 (528226) 115 kV line CKT 1, near PECOS 3 (528178) 115 kV. a. Apply fault at the PECOS 3 (528178) 115 kV Bus. b. Clear fault after 7 cycles by tripping the faulted line. c. Wait 20 cycles, and then re-close the line in (b) back into the fault. d. Leave Fault on for 7 cycles, then trip the line in (b) and remove fault.
FLT9058-3PH	P1	3 Phase fault on PECOS 3 (528178) 115 kV to CARLSBAD 3 (528160) 115 kV line CKT 1, near PECOS 3 (528178) 115 kV. a. Apply fault at the PECOS 3 (528178) 115 kV Bus. b. Clear fault after 7 cycles by tripping the faulted line. c. Wait 20 cycles, and then re-close the line in (b) back into the fault. d. Leave Fault on for 7 cycles, then trip the line in (b) and remove fault.
FLT9059-3PH	P1	3 Phase fault on PECOS 3 (528178) 115 kV to CV-AZMESA 3 (528070) 115 kV line CKT 1, near PECOS 3 (528178) 115 kV. a. Apply fault at the PECOS 3 (528178) 115 kV Bus. b. Clear fault after 7 cycles by tripping the faulted line. c. Wait 20 cycles, and then re-close the line in (b) back into the fault. d. Leave Fault on for 7 cycles, then trip the line in (b) and remove fault.

Table 5-2 Continued

Fault ID	Planning Event	Fault Descriptions
FLT9060-3PH	P1	3 Phase fault on PECOS 3 (528178) 115 kV / PECOS 6 (528179) 230 kV / PECOS_TR1 1 (528176) 13.2 kV XFMR CKT 1, near PECOS 3 (528178) 115 kV. a. Apply fault at the PECOS 3 (528178) 115 kV Bus. b. Clear fault after 7 cycles by tripping the faulted line.
FLT9061-3PH	P1	3 Phase fault on EDDY_NORTH 6 (527799) 230 kV to 7-RIVERS 6 (528095) 230 kV line CKT 1, near EDDY_NORTH 6 (527799) 230 kV. a. Apply fault at the EDDY_NORTH 6 (527799) 230 kV Bus. b. Clear fault after 7 cycles by tripping the faulted line. c. Wait 20 cycles, and then re-close the line in (b) back into the fault. d. Leave Fault on for 7 cycles, then trip the line in (b) and remove fault.
FLT9062-3PH	P1	3 Phase fault on 7-RIVERS 6 (528095) 230 kV to EDDY_NORTH 6 (527799) 230 kV line CKT 1, near 7-RIVERS 6 (528095) 230 kV. a. Apply fault at the 7-RIVERS 6 (528095) 230 kV Bus. b. Clear fault after 7 cycles by tripping the faulted line. c. Wait 20 cycles, and then re-close the line in (b) back into the fault. d. Leave Fault on for 7 cycles, then trip the line in (b) and remove fault.
FLT9063-3PH	P1	3 Phase fault on 7-RIVERS 6 (528095) 230 kV to PECOS 6 (528179) 230 kV line CKT 1, near 7-RIVERS 6 (528095) 230 kV. a. Apply fault at the 7-RIVERS 6 (528095) 230 kV Bus. b. Clear fault after 7 cycles by tripping the faulted line. c. Wait 20 cycles, and then re-close the line in (b) back into the fault. d. Leave Fault on for 7 cycles, then trip the line in (b) and remove fault.
FLT9064-3PH	P1	3 Phase fault on 7-RIVERS 6 (528095) 230 kV / 7-RIVERS 3 (528094) 115 kV / 7-RIVER_TR11 (528090) 13.2 kV XFMR CKT 1, near 7-RIVERS 6 (528095) 230 kV. a. Apply fault at the 7-RIVERS 6 (528095) 230 kV Bus. b. Clear fault after 7 cycles by tripping the faulted line.
FLT9065-3PH	P1	3 Phase fault on EDDY_NORTH 6 (527799) 230 kV to CUNNIGHM_N 6 (527865) 230 kV line CKT 1, near EDDY_NORTH 6 (527799) 230 kV. a. Apply fault at the EDDY_NORTH 6 (527799) 230 kV Bus. b. Clear fault after 7 cycles by tripping the faulted line. c. Wait 20 cycles, and then re-close the line in (b) back into the fault. d. Leave Fault on for 7 cycles, then trip the line in (b) and remove fault.
FLT9066-3PH	P1	3 Phase fault on CUNNIGHM_N 6 (527865) 230 kV to EDDY_NORTH 6 (527799) 230 kV line CKT 1, near CUNNIGHM_N 6 (527865) 230 kV. a. Apply fault at the CUNNIGHM_N 6 (527865) 230 kV Bus. b. Clear fault after 7 cycles by tripping the faulted line. c. Wait 20 cycles, and then re-close the line in (b) back into the fault. d. Leave Fault on for 7 cycles, then trip the line in (b) and remove fault.
FLT9067-3PH	P1	3 Phase fault on CUNNIGHM_N 6 (527865) 230 kV to POTASH_JCT 6 (527963) 230 kV line CKT 1, near CUNNIGHM_N 6 (527865) 230 kV. a. Apply fault at the CUNNIGHM_N 6 (527865) 230 kV Bus. b. Clear fault after 7 cycles by tripping the faulted line. c. Wait 20 cycles, and then re-close the line in (b) back into the fault. d. Leave Fault on for 7 cycles, then trip the line in (b) and remove fault.
FLT9068-3PH	P1	3 Phase fault on CUNNIGHM_N 6 (527865) 230 kV to CUNINGHAM3 1 (527883) 13.8 kV XFMR CKT 1, near CUNNIGHM_N 6 (527865) 230 kV. a. Apply fault at the CUNNIGHM_N 6 (527865) 230 kV Bus. b. Clear fault after 7 cycles by tripping the faulted line. Trip generator(s) on the Bus CUNINGHAM3 1 (527883) 13.8 kV
FLT9069-3PH	P1	3 Phase fault on CUNNIGHM_S 6 (527867) 230 kV to CUNINGHAM2 1 (527882) 20 kV XFMR CKT 1, near CUNNIGHM_S 6 (527867) 230 kV. a. Apply fault at the CUNNIGHM_S 6 (527867) 230 kV Bus. b. Clear fault after 7 cycles by tripping the faulted line. Trip generator(s) on the Bus CUNINGHAM2 1 (527882) 20 kV
FLT9070-3PH	P1	3 Phase fault on CUNNIGHM_S 6 (527867) 230 kV to HOBBS_INT 6 (527894) 230 kV line CKT 1, near CUNNIGHM_S 6 (527867) 230 kV. a. Apply fault at the CUNNIGHM_S 6 (527867) 230 kV Bus. b. Clear fault after 7 cycles by tripping the faulted line. c. Wait 20 cycles, and then re-close the line in (b) back into the fault. d. Leave Fault on for 7 cycles, then trip the line in (b) and remove fault.
FLT9071-3PH	P1	3 Phase fault on CUNNIGHM_S 6 (527867) 230 kV / CUNNINHAM 3 (527864) 115 kV / CUNNHM_TR1 1 (527863) 13.2 kV XFMR CKT 1, near CUNNIGHM_S 6 (527867) 230 kV. a. Apply fault at the CUNNIGHM_S 6 (527867) 230 kV Bus. b. Clear fault after 7 cycles by tripping the faulted line.

Table 5-2 Continued

Fault ID	Planning Event	Fault Descriptions
FLT9072-3PH	P1	3 Phase fault on SAMSON 3 (527546) 115 kV to ROSWLL_INT 3 (527564) 115 kV line CKT 1, near SAMSON 3 (527546) 115 kV. a. Apply fault at the SAMSON 3 (527546) 115 kV Bus. b. Clear fault after 7 cycles by tripping the faulted line. c. Wait 20 cycles, and then re-close the line in (b) back into the fault. d. Leave Fault on for 7 cycles, then trip the line in (b) and remove fault.
FLT9073-3PH	P1	3 Phase fault on ROSWLL_INT 3 (527564) 115 kV to SAMSON 3 (527546) 115 kV line CKT 1, near ROSWLL_INT 3 (527564) 115 kV. a. Apply fault at the ROSWLL_INT 3 (527564) 115 kV Bus. b. Clear fault after 7 cycles by tripping the faulted line. c. Wait 20 cycles, and then re-close the line in (b) back into the fault. d. Leave Fault on for 7 cycles, then trip the line in (b) and remove fault.
FLT9074-3PH	P1	3 Phase fault on ROSWLL_INT 3 (527564) 115 kV to TWEEDY 3 (527597) 115 kV line CKT 1, near ROSWLL_INT 3 (527564) 115 kV. a. Apply fault at the ROSWLL_INT 3 (527564) 115 kV Bus. b. Clear fault after 7 cycles by tripping the faulted line. c. Wait 20 cycles, and then re-close the line in (b) back into the fault. d. Leave Fault on for 7 cycles, then trip the line in (b) and remove fault.
FLT9075-3PH	P1	3 Phase fault on ROSWLL_INT 3 (527564) 115 kV / ROSWLL_INT 2 (527563) 69 kV / ROSWELL_TR11 (527561) 13.2 kV XFMR CKT 1, near ROSWLL_INT 3 (527564) 115 kV. a. Apply fault at the ROSWLL_INT 3 (527564) 115 kV Bus. b. Clear fault after 7 cycles by tripping the faulted line.
FLT9076-3PH	P1	3 Phase fault on ROSWLL_INT 3 (527564) 115 kV to CAPITAN 3 (527541) 115 kV line CKT 1, near ROSWLL_INT 3 (527564) 115 kV. a. Apply fault at the ROSWLL_INT 3 (527564) 115 kV Bus. b. Clear fault after 7 cycles by tripping the faulted line. c. Wait 20 cycles, and then re-close the line in (b) back into the fault. d. Leave Fault on for 7 cycles, then trip the line in (b) and remove fault.
FLT9077-3PH	P1	3 Phase fault on ROSWLL_INT 3 (527564) 115 kV to SW4J795_W 3 (527534) 115 kV line CKT 1, near ROSWLL_INT 3 (527564) 115 kV. a. Apply fault at the ROSWLL_INT 3 (527564) 115 kV Bus. b. Clear fault after 7 cycles by tripping the faulted line. c. Wait 20 cycles, and then re-close the line in (b) back into the fault. d. Leave Fault on for 7 cycles, then trip the line in (b) and remove fault.
FLT9078-3PH	P1	3 Phase fault on ROSWLL_INT 3 (527564) 115 kV to SW4J795_E 3 (527533) 115 kV line CKT 1, near ROSWLL_INT 3 (527564) 115 kV. a. Apply fault at the ROSWLL_INT 3 (527564) 115 kV Bus. b. Clear fault after 7 cycles by tripping the faulted line. c. Wait 20 cycles, and then re-close the line in (b) back into the fault. d. Leave Fault on for 7 cycles, then trip the line in (b) and remove fault.
FLT9079-3PH	P1	3 Phase fault on PRICE_TAP 3 (527509) 115 kV to CAPITAN 3 (527541) 115 kV line CKT 1, near PRICE_TAP 3 (527509) 115 kV. a. Apply fault at the PRICE_TAP 3 (527509) 115 kV Bus. b. Clear fault after 7 cycles by tripping the faulted line. c. Wait 20 cycles, and then re-close the line in (b) back into the fault. d. Leave Fault on for 7 cycles, then trip the line in (b) and remove fault.
FLT9080-3PH	P1	3 Phase fault on CAPITAN 3 (527541) 115 kV to PRICE_TAP 3 (527509) 115 kV line CKT 1, near CAPITAN 3 (527541) 115 kV. a. Apply fault at the CAPITAN 3 (527541) 115 kV Bus. b. Clear fault after 7 cycles by tripping the faulted line. c. Wait 20 cycles, and then re-close the line in (b) back into the fault. d. Leave Fault on for 7 cycles, then trip the line in (b) and remove fault.
FLT9081-3PH	P1	3 Phase fault on CAPITAN 3 (527541) 115 kV to ROSWLL_INT 3 (527564) 115 kV line CKT 1, near CAPITAN 3 (527541) 115 kV. a. Apply fault at the CAPITAN 3 (527541) 115 kV Bus. b. Clear fault after 7 cycles by tripping the faulted line. c. Wait 20 cycles, and then re-close the line in (b) back into the fault. d. Leave Fault on for 7 cycles, then trip the line in (b) and remove fault.

Table 5-2 Continued

Fault ID	Planning Event	Fault Descriptions
FLT9082-3PH	P1	3 Phase fault on PRICE_TAP 3 (527509) 115 kV to PRICE 3 (527508) 115 kV line CKT 1, near PRICE_TAP 3 (527509) 115 kV. a. Apply fault at the PRICE_TAP 3 (527509) 115 kV Bus. b. Clear fault after 7 cycles by tripping the faulted line. c. Wait 20 cycles, and then re-close the line in (b) back into the fault. d. Leave Fault on for 7 cycles, then trip the line in (b) and remove fault.
FLT9083-3PH	P1	3 Phase fault on URTON 3 (527501) 115 kV to ROSWELL_CTY3 (527522) 115 kV line CKT 1, near URTON 3 (527501) 115 kV. a. Apply fault at the URTON 3 (527501) 115 kV Bus. b. Clear fault after 7 cycles by tripping the faulted line. c. Wait 20 cycles, and then re-close the line in (b) back into the fault. d. Leave Fault on for 7 cycles, then trip the line in (b) and remove fault.
FLT9084-3PH	P1	3 Phase fault on ROSWELL_CTY3 (527522) 115 kV to URTON 3 (527501) 115 kV line CKT 1, near ROSWELL_CTY3 (527522) 115 kV. a. Apply fault at the ROSWELL_CTY3 (527522) 115 kV Bus. b. Clear fault after 7 cycles by tripping the faulted line. c. Wait 20 cycles, and then re-close the line in (b) back into the fault. d. Leave Fault on for 7 cycles, then trip the line in (b) and remove fault.
FLT9085-3PH	P1	3 Phase fault on ROSWELL_CTY3 (527522) 115 kV to SW4J795_W 3 (527534) 115 kV line CKT 1, near ROSWELL_CTY3 (527522) 115 kV. a. Apply fault at the ROSWELL_CTY3 (527522) 115 kV Bus. b. Clear fault after 7 cycles by tripping the faulted line. c. Wait 20 cycles, and then re-close the line in (b) back into the fault. d. Leave Fault on for 7 cycles, then trip the line in (b) and remove fault.

5.3 Scenario 1 Results

Table 5-3 shows the relevant results of the fault events simulated for each of the modified models in Scenario 1. Existing DISIS base case issues are documented separately in Appendix C. The associated stability plots are also provided in Appendix C.

Table 5-3: Scenario 1 Dynamic Stability Results (EGF = 0 MW, SGF = 50.32 MW)

Fault ID	25SP			25WP		
	Voltage Violation	Voltage Recovery	Stable	Voltage Violation	Voltage Recovery	Stable
FLT1000-SB	Pass	Pass	Stable	Pass	Pass	Stable
FLT1001-SB	Pass	Pass	Stable	Pass	Pass	Stable
FLT1002-SB	Pass	Pass	Stable	Pass	Pass	Stable
FLT1003-SB	Pass	Pass	Stable	Pass	Pass	Stable
FLT1004-SB	Pass	Pass	Stable	Pass	Pass	Stable
FLT1005-SB	Pass	Pass	Stable	Pass	Pass	Stable
FLT1006-SB	Pass	Pass	Stable	Pass	Pass	Stable
FLT1007-SB	Pass	Pass	Stable	Pass	Pass	Stable
FLT1008-SB	Pass	Pass	Stable	Pass	Pass	Stable
FLT1009-SB	Pass	Pass	Stable	Pass	Pass	Stable
FLT1010-SB	Pass	Pass	Stable	Pass	Pass	Stable
FLT1011-SB	Pass	Pass	Stable	Pass	Pass	Stable
FLT1012-SB	Pass	Pass	Stable	Pass	Pass	Stable
FLT1013-SB	Pass	Pass	Stable	Pass	Pass	Stable
FLT1014-SB	Pass	Pass	Stable	Pass	Pass	Stable

Table 5-3 continued

Fault ID	25SP			25WP		
	Voltage Violation	Voltage Recovery	Stable	Voltage Violation	Voltage Recovery	Stable
FLT1015-SB	Pass	Pass	Stable	Pass	Pass	Stable
FLT1016-SB	Pass	Pass	Stable	Pass	Pass	Stable
FLT1017-SB	Pass	Pass	Stable	Pass	Pass	Stable
FLT1018-SB	Pass	Pass	Stable	Pass	Pass	Stable
FLT1019-SB	Pass	Pass	Stable	Pass	Pass	Stable
FLT1020-SB	Pass	Pass	Stable	Pass	Pass	Stable
FLT1021-SB	Pass	Pass	Stable	Pass	Pass	Stable
FLT1022-SB	Pass	Pass	Stable	Pass	Pass	Stable
FLT1023-SB	Pass	Pass	Stable	Pass	Pass	Stable
FLT1024-SB	Pass	Pass	Stable	Pass	Pass	Stable
FLT1025-SB	Pass	Pass	Stable	Pass	Pass	Stable
FLT1026-SB	Pass	Pass	Stable	Pass	Pass	Stable
FLT1027-SB	Pass	Pass	Stable	Pass	Pass	Stable
FLT1028-SB	Pass	Pass	Stable	Pass	Pass	Stable
FLT1029-SB	Pass	Pass	Stable	Pass	Pass	Stable
FLT9000-3PH	Pass	Pass	Stable	Pass	Pass	Stable
FLT9001-3PH	Pass	Pass	Stable	Pass	Pass	Stable
FLT9002-3PH	Pass	Pass	Stable	Pass	Pass	Stable
FLT9003-3PH	Pass	Pass	Stable	Pass	Pass	Stable
FLT9004-3PH	Pass	Pass	Stable	Pass	Pass	Stable
FLT9005-3PH	Pass	Pass	Stable	Pass	Pass	Stable
FLT9006-3PH	Pass	Pass	Stable	Pass	Pass	Stable
FLT9007-3PH	Pass	Pass	Stable	Pass	Pass	Stable
FLT9008-3PH	Pass	Pass	Stable	Pass	Pass	Stable
FLT9009-3PH	Pass	Pass	Stable	Pass	Pass	Stable
FLT9010-3PH	Pass	Pass	Stable	Pass	Pass	Stable
FLT9011-3PH	Pass	Pass	Stable	Pass	Pass	Stable
FLT9012-3PH	Pass	Pass	Stable	Pass	Pass	Stable
FLT9013-3PH	Pass	Pass	Stable	Pass	Pass	Stable
FLT9014-3PH	Pass	Pass	Stable	Pass	Pass	Stable
FLT9015-3PH	Pass	Pass	Stable	Pass	Pass	Stable
FLT9016-3PH	Pass	Pass	Stable	Pass	Pass	Stable
FLT9017-3PH	Pass	Pass	Stable	Pass	Pass	Stable
FLT9018-3PH	Pass	Pass	Stable	Pass	Pass	Stable
FLT9019-3PH	Pass	Pass	Stable	Pass	Pass	Stable
FLT9020-3PH	Pass	Pass	Stable	Pass	Pass	Stable
FLT9021-3PH	Pass	Pass	Stable	Pass	Pass	Stable

Table 5-3 continued

Fault ID	25SP			25WP		
	Voltage Violation	Voltage Recovery	Stable	Voltage Violation	Voltage Recovery	Stable
FLT9022-3PH	Pass	Pass	Stable	Pass	Pass	Stable
FLT9023-3PH	Pass	Pass	Stable	Pass	Pass	Stable
FLT9024-3PH	Pass	Pass	Stable	Pass	Pass	Stable
FLT9025-3PH	Pass	Pass	Stable	Pass	Pass	Stable
FLT9026-3PH	Pass	Pass	Stable	Pass	Pass	Stable
FLT9027-3PH	Pass	Pass	Stable	Pass	Pass	Stable
FLT9028-3PH	Pass	Pass	Stable	Pass	Pass	Stable
FLT9029-3PH	Pass	Pass	Stable	Pass	Pass	Stable
FLT9030-3PH	Pass	Pass	Stable	Pass	Pass	Stable
FLT9031-3PH	Pass	Pass	Stable	Pass	Pass	Stable
FLT9032-3PH	Pass	Pass	Stable	Pass	Pass	Stable
FLT9033-3PH	Pass	Pass	Stable	Pass	Pass	Stable
FLT9034-3PH	Pass	Pass	Stable	Pass	Pass	Stable
FLT9035-3PH	Pass	Pass	Stable	Pass	Pass	Stable
FLT9036-3PH	Pass	Pass	Stable	Pass	Pass	Stable
FLT9037-3PH	Pass	Pass	Stable	Pass	Pass	Stable
FLT9038-3PH	Pass	Pass	Stable	Pass	Pass	Stable
FLT9039-3PH	Pass	Pass	Stable	Pass	Pass	Stable
FLT9040-3PH	Pass	Pass	Stable	Pass	Pass	Stable
FLT9041-3PH	Pass	Pass	Stable	Pass	Pass	Stable
FLT9042-3PH	Pass	Pass	Stable	Pass	Pass	Stable
FLT9043-3PH	Pass	Pass	Stable	Pass	Pass	Stable
FLT9044-3PH	Pass	Pass	Stable	Pass	Pass	Stable
FLT9045-3PH	Pass	Pass	Stable	Pass	Pass	Stable
FLT9046-3PH	Pass	Pass	Stable	Pass	Pass	Stable
FLT9047-3PH	Pass	Pass	Stable	Pass	Pass	Stable
FLT9048-3PH	Pass	Pass	Stable	Pass	Pass	Stable
FLT9049-3PH	Pass	Pass	Stable	Pass	Pass	Stable
FLT9050-3PH	Pass	Pass	Stable	Pass	Pass	Stable
FLT9051-3PH	Pass	Pass	Stable	Pass	Pass	Stable
FLT9052-3PH	Pass	Pass	Stable	Pass	Pass	Stable
FLT9053-3PH	Pass	Pass	Stable	Pass	Pass	Stable
FLT9054-3PH	Pass	Pass	Stable	Pass	Pass	Stable
FLT9055-3PH	Pass	Pass	Stable	Pass	Pass	Stable
FLT9056-3PH	Pass	Pass	Stable	Pass	Pass	Stable
FLT9057-3PH	Pass	Pass	Stable	Pass	Pass	Stable
FLT9058-3PH	Pass	Pass	Stable	Pass	Pass	Stable

Table 5-3 continued

Fault ID	25SP			25WP		
	Voltage Violation	Voltage Recovery	Stable	Voltage Violation	Voltage Recovery	Stable
FLT9059-3PH	Pass	Pass	Stable	Pass	Pass	Stable
FLT9060-3PH	Pass	Pass	Stable	Pass	Pass	Stable
FLT9061-3PH	Pass	Pass	Stable	Pass	Pass	Stable
FLT9062-3PH	Pass	Pass	Stable	Pass	Pass	Stable
FLT9063-3PH	Pass	Pass	Stable	Pass	Pass	Stable
FLT9064-3PH	Pass	Pass	Stable	Pass	Pass	Stable
FLT9065-3PH	Pass	Pass	Stable	Pass	Pass	Stable
FLT9066-3PH	Pass	Pass	Stable	Pass	Pass	Stable
FLT9067-3PH	Pass	Pass	Stable	Pass	Pass	Stable
FLT9068-3PH	Pass	Pass	Stable	Pass	Pass	Stable
FLT9069-3PH	Pass	Pass	Stable	Pass	Pass	Stable
FLT9070-3PH	Pass	Pass	Stable	Pass	Pass	Stable
FLT9071-3PH	Pass	Pass	Stable	Pass	Pass	Stable
FLT9072-3PH	Pass	Pass	Stable	Pass	Pass	Stable
FLT9073-3PH	Pass	Pass	Stable	Pass	Pass	Stable
FLT9074-3PH	Pass	Pass	Stable	Pass	Pass	Stable
FLT9075-3PH	Pass	Pass	Stable	Pass	Pass	Stable
FLT9076-3PH	Pass	Pass	Stable	Pass	Pass	Stable
FLT9077-3PH	Pass	Pass	Stable	Pass	Pass	Stable
FLT9078-3PH	Pass	Pass	Stable	Pass	Pass	Stable
FLT9079-3PH	Pass	Pass	Stable	Pass	Pass	Stable
FLT9080-3PH	Pass	Pass	Stable	Pass	Pass	Stable
FLT9081-3PH	Pass	Pass	Stable	Pass	Pass	Stable
FLT9082-3PH	Pass	Pass	Stable	Pass	Pass	Stable
FLT9083-3PH	Pass	Pass	Stable	Pass	Pass	Stable
FLT9084-3PH	Pass	Pass	Stable	Pass	Pass	Stable
FLT9085-3PH	Pass	Pass	Stable	Pass	Pass	Stable

The results of the Scenario 1 dynamic stability showed several existing base case issues that were found in both the original DISIS-2021-001 model and the model with GEN-2025-SR27 included. These issues were not attributed to the GEN-2025-SR27 surplus request and detailed in Appendix C.

There were no damping or voltage recovery violations attributed to the GEN-2025-SR27 surplus request observed during the simulated faults. Additionally, the project was found to stay connected during the contingencies that were studied and, therefore, will meet the Low Voltage Ride Through (LVRT) requirements of FERC Order #661A.

5.4 Scenario 2 Results

Table 5-4 shows the relevant results of the fault events simulated for each of the modified models in Scenario 2. Existing DISIS base case issues are documented separately in Appendix C. The associated stability plots are also provided in Appendix C.

Table 5-4: Scenario 2 Dynamic Stability Results (EGF = 19.68 MW, SGF = 50.32 MW)

Fault ID	25SP			25WP		
	Voltage Violation	Voltage Recovery	Stable	Voltage Violation	Voltage Recovery	Stable
FLT1000-SB	Pass	Pass	Stable	Pass	Pass	Stable
FLT1001-SB	Pass	Pass	Stable	Pass	Pass	Stable
FLT1002-SB	Pass	Pass	Stable	Pass	Pass	Stable
FLT1003-SB	Pass	Pass	Stable	Pass	Pass	Stable
FLT1004-SB	Pass	Pass	Stable	Pass	Pass	Stable
FLT1005-SB	Pass	Pass	Stable	Pass	Pass	Stable
FLT1006-SB	Pass	Pass	Stable	Pass	Pass	Stable
FLT1007-SB	Pass	Pass	Stable	Pass	Pass	Stable
FLT1008-SB	Pass	Pass	Stable	Pass	Pass	Stable
FLT1009-SB	Pass	Pass	Stable	Pass	Pass	Stable
FLT1010-SB	Pass	Pass	Stable	Pass	Pass	Stable
FLT1011-SB	Pass	Pass	Stable	Pass	Pass	Stable
FLT1012-SB	Pass	Pass	Stable	Pass	Pass	Stable
FLT1013-SB	Pass	Pass	Stable	Pass	Pass	Stable
FLT1014-SB	Pass	Pass	Stable	Pass	Pass	Stable
FLT1015-SB	Pass	Pass	Stable	Pass	Pass	Stable
FLT1016-SB	Pass	Pass	Stable	Pass	Pass	Stable
FLT1017-SB	Pass	Pass	Stable	Pass	Pass	Stable
FLT1018-SB	Pass	Pass	Stable	Pass	Pass	Stable
FLT1019-SB	Pass	Pass	Stable	Pass	Pass	Stable
FLT1020-SB	Pass	Pass	Stable	Pass	Pass	Stable
FLT1021-SB	Pass	Pass	Stable	Pass	Pass	Stable
FLT1022-SB	Pass	Pass	Stable	Pass	Pass	Stable
FLT1023-SB	Pass	Pass	Stable	Pass	Pass	Stable
FLT1024-SB	Pass	Pass	Stable	Pass	Pass	Stable
FLT1025-SB	Pass	Pass	Stable	Pass	Pass	Stable
FLT1026-SB	Pass	Pass	Stable	Pass	Pass	Stable
FLT1027-SB	Pass	Pass	Stable	Pass	Pass	Stable
FLT1028-SB	Pass	Pass	Stable	Pass	Pass	Stable
FLT1029-SB	Pass	Pass	Stable	Pass	Pass	Stable
FLT9000-3PH	Pass	Pass	Stable	Pass	Pass	Stable
FLT9001-3PH	Pass	Pass	Stable	Pass	Pass	Stable
FLT9002-3PH	Pass	Pass	Stable	Pass	Pass	Stable

Table 5-4 continued

Fault ID	25SP			25WP		
	Voltage Violation	Voltage Recovery	Stable	Voltage Violation	Voltage Recovery	Stable
FLT9003-3PH	Pass	Pass	Stable	Pass	Pass	Stable
FLT9004-3PH	Pass	Pass	Stable	Pass	Pass	Stable
FLT9005-3PH	Pass	Pass	Stable	Pass	Pass	Stable
FLT9006-3PH	Pass	Pass	Stable	Pass	Pass	Stable
FLT9007-3PH	Pass	Pass	Stable	Pass	Pass	Stable
FLT9008-3PH	Pass	Pass	Stable	Pass	Pass	Stable
FLT9009-3PH	Pass	Pass	Stable	Pass	Pass	Stable
FLT9010-3PH	Pass	Pass	Stable	Pass	Pass	Stable
FLT9011-3PH	Pass	Pass	Stable	Pass	Pass	Stable
FLT9012-3PH	Pass	Pass	Stable	Pass	Pass	Stable
FLT9013-3PH	Pass	Pass	Stable	Pass	Pass	Stable
FLT9014-3PH	Pass	Pass	Stable	Pass	Pass	Stable
FLT9015-3PH	Pass	Pass	Stable	Pass	Pass	Stable
FLT9016-3PH	Pass	Pass	Stable	Pass	Pass	Stable
FLT9017-3PH	Pass	Pass	Stable	Pass	Pass	Stable
FLT9018-3PH	Pass	Pass	Stable	Pass	Pass	Stable
FLT9019-3PH	Pass	Pass	Stable	Pass	Pass	Stable
FLT9020-3PH	Pass	Pass	Stable	Pass	Pass	Stable
FLT9021-3PH	Pass	Pass	Stable	Pass	Pass	Stable
FLT9022-3PH	Pass	Pass	Stable	Pass	Pass	Stable
FLT9023-3PH	Pass	Pass	Stable	Pass	Pass	Stable
FLT9024-3PH	Pass	Pass	Stable	Pass	Pass	Stable
FLT9025-3PH	Pass	Pass	Stable	Pass	Pass	Stable
FLT9026-3PH	Pass	Pass	Stable	Pass	Pass	Stable
FLT9027-3PH	Pass	Pass	Stable	Pass	Pass	Stable
FLT9028-3PH	Pass	Pass	Stable	Pass	Pass	Stable
FLT9029-3PH	Pass	Pass	Stable	Pass	Pass	Stable
FLT9030-3PH	Pass	Pass	Stable	Pass	Pass	Stable
FLT9031-3PH	Pass	Pass	Stable	Pass	Pass	Stable
FLT9032-3PH	Pass	Pass	Stable	Pass	Pass	Stable
FLT9033-3PH	Pass	Pass	Stable	Pass	Pass	Stable
FLT9034-3PH	Pass	Pass	Stable	Pass	Pass	Stable
FLT9035-3PH	Pass	Pass	Stable	Pass	Pass	Stable
FLT9036-3PH	Pass	Pass	Stable	Pass	Pass	Stable
FLT9037-3PH	Pass	Pass	Stable	Pass	Pass	Stable
FLT9038-3PH	Pass	Pass	Stable	Pass	Pass	Stable
FLT9039-3PH	Pass	Pass	Stable	Pass	Pass	Stable

Table 5-4 continued

Fault ID	25SP			25WP		
	Voltage Violation	Voltage Recovery	Stable	Voltage Violation	Voltage Recovery	Stable
FLT9040-3PH	Pass	Pass	Stable	Pass	Pass	Stable
FLT9041-3PH	Pass	Pass	Stable	Pass	Pass	Stable
FLT9042-3PH	Pass	Pass	Stable	Pass	Pass	Stable
FLT9043-3PH	Pass	Pass	Stable	Pass	Pass	Stable
FLT9044-3PH	Pass	Pass	Stable	Pass	Pass	Stable
FLT9045-3PH	Pass	Pass	Stable	Pass	Pass	Stable
FLT9046-3PH	Pass	Pass	Stable	Pass	Pass	Stable
FLT9047-3PH	Pass	Pass	Stable	Pass	Pass	Stable
FLT9048-3PH	Pass	Pass	Stable	Pass	Pass	Stable
FLT9049-3PH	Pass	Pass	Stable	Pass	Pass	Stable
FLT9050-3PH	Pass	Pass	Stable	Pass	Pass	Stable
FLT9051-3PH	Pass	Pass	Stable	Pass	Pass	Stable
FLT9052-3PH	Pass	Pass	Stable	Pass	Pass	Stable
FLT9053-3PH	Pass	Pass	Stable	Pass	Pass	Stable
FLT9054-3PH	Pass	Pass	Stable	Pass	Pass	Stable
FLT9055-3PH	Pass	Pass	Stable	Pass	Pass	Stable
FLT9056-3PH	Pass	Pass	Stable	Pass	Pass	Stable
FLT9057-3PH	Pass	Pass	Stable	Pass	Pass	Stable
FLT9058-3PH	Pass	Pass	Stable	Pass	Pass	Stable
FLT9059-3PH	Pass	Pass	Stable	Pass	Pass	Stable
FLT9060-3PH	Pass	Pass	Stable	Pass	Pass	Stable
FLT9061-3PH	Pass	Pass	Stable	Pass	Pass	Stable
FLT9062-3PH	Pass	Pass	Stable	Pass	Pass	Stable
FLT9063-3PH	Pass	Pass	Stable	Pass	Pass	Stable
FLT9064-3PH	Pass	Pass	Stable	Pass	Pass	Stable
FLT9065-3PH	Pass	Pass	Stable	Pass	Pass	Stable
FLT9066-3PH	Pass	Pass	Stable	Pass	Pass	Stable
FLT9067-3PH	Pass	Pass	Stable	Pass	Pass	Stable
FLT9068-3PH	Pass	Pass	Stable	Pass	Pass	Stable
FLT9069-3PH	Pass	Pass	Stable	Pass	Pass	Stable
FLT9070-3PH	Pass	Pass	Stable	Pass	Pass	Stable
FLT9071-3PH	Pass	Pass	Stable	Pass	Pass	Stable
FLT9072-3PH	Pass	Pass	Stable	Pass	Pass	Stable
FLT9073-3PH	Pass	Pass	Stable	Pass	Pass	Stable
FLT9074-3PH	Pass	Pass	Stable	Pass	Pass	Stable
FLT9075-3PH	Pass	Pass	Stable	Pass	Pass	Stable
FLT9076-3PH	Pass	Pass	Stable	Pass	Pass	Stable

Table 5-4 continued

Fault ID	25SP			25WP		
	Voltage Violation	Voltage Recovery	Stable	Voltage Violation	Voltage Recovery	Stable
FLT9077-3PH	Pass	Pass	Stable	Pass	Pass	Stable
FLT9078-3PH	Pass	Pass	Stable	Pass	Pass	Stable
FLT9079-3PH	Pass	Pass	Stable	Pass	Pass	Stable
FLT9080-3PH	Pass	Pass	Stable	Pass	Pass	Stable
FLT9081-3PH	Pass	Pass	Stable	Pass	Pass	Stable
FLT9082-3PH	Pass	Pass	Stable	Pass	Pass	Stable
FLT9083-3PH	Pass	Pass	Stable	Pass	Pass	Stable
FLT9084-3PH	Pass	Pass	Stable	Pass	Pass	Stable
FLT9085-3PH	Pass	Pass	Stable	Pass	Pass	Stable

The results of the Scenario 2 dynamic stability showed several existing base case issues that were found in both the original DISIS-2021-001 model and the model with GEN-2025-SR27 included. These issues were not attributed to the GEN-2025-SR27 surplus request and detailed in Appendix C.

There were no damping or voltage recovery violations attributed to the GEN-2025-SR27 surplus request observed during the simulated faults. Additionally, the project was found to stay connected during the contingencies that were studied and, therefore, will meet the Low Voltage Ride Through (LVRT) requirements of FERC Order #661A.

6.0 Necessary Interconnection Facilities and Network Upgrades

This study identified the impact of the Surplus Interconnection Service on the transmission system reliability and any additional Interconnection Facilities or Network Upgrades necessary. The Surplus Interconnection Service is only available up to the amount that can be accommodated without requiring additional Network Upgrades unless (a) those additional Network Upgrades are either (1) located at the Point of Interconnection substation and at the same voltage level as the Generating Facility with an effective GIA, or (2) are System Protection Facilities; and (b) there are no material adverse impacts on the cost or timing of any Interconnection Requests pending at the time the Surplus Interconnection Service request is submitted.

6.1 Interconnection Facilities

This study did not identify any additional Interconnection Facilities required by the addition of the SGF.

6.2 Network Upgrades

This study did not identify any Network Upgrades required by the addition of the SGF. SPP will reach out to the TO and/or TOP to determine if there are any additional Network Upgrades that are either (1) located at the Point of Interconnection substation and at the same voltage level as the Generating Facility with an effective GIA, or (2) are System Protection Facilities.

7.0 Surplus Interconnection Service Determination and Requirements

In accordance with Attachment V of the SPP Tariff, SPP shall evaluate the request for Surplus Interconnection Service and inform the Interconnection Customer in writing of whether the Surplus Interconnection Service can be utilized without negatively impacting the reliability of the Transmission System and without any additional Network Upgrades necessary except those specified in the SPP Tariff.

7.1 Surplus Service Determination

SPP determined the request for Surplus Interconnection Service does not negatively impact the reliability of the Transmission System and no required Network Upgrades or Interconnection Facilities were identified by this Surplus Interconnection Service Impact Study performed by Aneden. Aneden evaluated the impact of the requested Surplus Interconnection Service on the prior study results and determined that the requested Surplus Interconnection Service resulted in similar dynamic stability and short circuit analyses and that the prior study steady-state results are not negatively impacted.

SPP has determined that GEN-2025-SR27 may utilize the requested 50 MW of Surplus Interconnection Service being made available by GEN-2014-033.

7.2 Surplus Service Requirements

The amount of Surplus Interconnection Service available to be used is limited by the amount of Interconnection Service granted to the existing interconnection customer at the same POI. The combined generation from both the SGF and the EGF may not exceed 70 MW at the POI, which is the total Interconnection Service amount currently granted to the EGF.

The customer must install monitoring and control equipment as needed to ensure that the SGF does not exceed the granted surplus amount and to ensure that combination of the SGF and EGF power injected at the POI does not exceed the Interconnection Service amount listed in the EGF's GIA. The monitoring and control scheme may be reviewed by the TO and documented in Appendix C of the SGF GIA.

SPP will reach out to the TO and/or TOP to determine if there are any additional Network Upgrades that are either (1) located at the Point of Interconnection substation and at the same voltage level as the Generating Facility with an effective GIA, or (2) are System Protection Facilities.