



Report on

GEN-2023-SR9 Surplus Service Impact Study

Revision R1 May 19, 2023

Submitted to
Southwest Power Pool



anedenconsulting.com

TABLE OF CONTENTS

Revision History R-1

Executive Summary ES-1

1.0 Scope of Study 1

 1.1 Reactive Power Analysis..... 1

 1.2 Short Circuit Analysis 1

 1.3 Stability Analysis 1

 1.4 Steady-State Analysis..... 1

 1.5 Necessary Interconnection Facilities & Network Upgrades 2

 1.6 Study Limitations 2

2.0 Surplus Interconnection Service Request 3

3.0 Reactive Power Analysis..... 6

 3.1 Methodology and Criteria 6

 3.2 Results..... 6

4.0 Short Circuit Analysis 8

 4.1 Methodology 8

 4.2 Results..... 8

5.0 Dynamic Stability Analysis..... 10

 5.1 Methodology and Criteria 10

 5.2 Fault Definitions 11

 5.3 Scenario 1 Results 14

 5.4 Scenario 2 Results 15

6.0 Necessary Interconnection Facilities and Network Upgrades 16

 6.1 Interconnection Facilities 16

 6.2 Network Upgrades 16

7.0 Surplus Interconnection Service Determination and Requirements..... 17

 7.1 Surplus Service Determination 17

 7.2 Surplus Service Requirements..... 17

LIST OF TABLES

Table ES-1: EGF & SGF Configuration	ES-1
Table ES-2: SGF Interconnection Configuration	ES-2
Table 2-1: EGF & SGF Configuration	3
Table 2-2: SGF Interconnection Configuration	5
Table 4-1: Short Circuit Model Parameters*	8
Table 4-2: POI Short Circuit Comparison Results	8
Table 4-3: 25SP Short Circuit Comparison Results	9
Table 5-1: Study Scenarios (Generator Dispatch MW)	10
Table 5-2: Fault Definitions	11
Table 5-3: Scenario 1 Dynamic Stability Results (EGF = 0 MW, SGF = 50 MW)	14
Table 5-4: Scenario 2 Dynamic Stability Results (EGF = 29.96 MW, SGF = 50 MW)	15

LIST OF FIGURES

Figure 2-1: GEN-2011-025 Single Line Diagram (EGF Existing Configuration*)	4
Figure 2-2: GEN-2011-025 & GEN-2023-SR9 Single Line Diagram (EGF & SGF Configuration)	4
Figure 3-1: GEN-2023-SR9 Single Line Diagram (Shunt Sizes)	7

APPENDICES

APPENDIX A: GEN-2023-SR9 Generator Dynamic Model

APPENDIX B: Short Circuit Results

APPENDIX C: Dynamic Stability Results with Existing Base Case Issues & Simulation Plots

Revision History

DATE OR VERSION NUMBER	AUTHOR	CHANGE DESCRIPTION
05/19/2023	Aneden Consulting	Initial Report Issued

Executive Summary

Aneden Consulting (Aneden) was retained by the Southwest Power Pool (SPP) to perform a Surplus Interconnection Service Impact Study (Study) for GEN-2023-SR9 to utilize the Surplus Interconnection Service being made available by GEN-2011-025 at its existing Point of Interconnection (POI) on the Floyd County to Crosby County 115 kV line in the Southwestern Public Service (SPS) control area.

GEN-2023-SR9, the proposed Surplus Generating Facility (SGF), will connect to the existing GEN-2011-025 main collection substation and share its main power transformer.

GEN-2011-025, the Existing Generating Facility (EGF), has an effective Generator Interconnection Agreement (GIA) with a POI capacity of 79.96 MW and is making 50 MW of Surplus Interconnection Service available at its point of interconnection. Per the SPP Open Access Transmission Tariff (SPP Tariff), the amount of Surplus Interconnection Service available to the SGF is limited by the amount of Interconnection Service granted to the EGF at the same POI. In addition, the Surplus Interconnection Service is only available up to the amount that can be accommodated without requiring Network Upgrades except those specified in the SPP Tariff¹.

The proposed SGF configuration consists of 14 x PE HEM FP4200M Battery Energy Storage System (BESS) inverters operating at 3.5714 MW for a total assumed dispatch of 50 MW. The inverters are rated at 4.2 MW, thus the generating capability of the SGF (58.8 MW) exceeds its requested Surplus Interconnection Service of 50 MW. The injection amount of the SGF must be limited to 50 MW at the POI. The combined generation from both the SGF and the EGF may not exceed 79.96 MW at the POI. GEN-2023-SR9 includes the use of a Power Plant Controller (PPC) to limit the power injection as required. The SGF and EGF information is shown in Table ES-1 below.

The detailed SGF configuration is captured in Table ES-2 below.

Table ES-1: EGF & SGF Configuration

Request	Interconnection Queue Capacity (MW)	Fuel Type	Point of Interconnection
GEN-2023-SR9 (SGF)	50	Battery/Storage	Tap on Floyd County 115 kV (525780) to Crosby County 115 kV (525926) (Blanco 115 kV 525803)
GEN-2011-025 (EGF)	79.96	Wind	Tap on Floyd County 115 kV (525780) to Crosby County 115 kV (525926) (Blanco 115 kV 525803)

¹ Allowed Network Upgrades detailed in SPP Open Access Transmission Tariff Attachment V Section 3.3

Table ES-2: SGF Interconnection Configuration

Facility	SGF Configuration
Point of Interconnection	Tap on Floyd County 115 kV (525780) to Crosby County 115 kV (525926) (Blanco 115 kV 525803)
Configuration/Capacity	14 x PE HEM FP4200M operating at 3.5714 MW (BESS) = 50 MW [dispatch] Units are rated at 4.2 MW, PPC to limit GEN-2023-SR9 to 50 MW at the POI and total POI injection w/ GEN-2011-025 to 79.96 MW
Generation Interconnection Line (Shared with the EGF and unchanged)	Length = 0.01 miles R = 0.000010 pu X = 0.000020 pu B = 0.000200 pu Rating MVA = 0 MVA
Main Substation Transformer ¹ (Shared with the EGF and unchanged)	X = 6.947%, R = 0.211%, Winding MVA = 57.4 MVA, Rating A/B/C MVA = 57/76/96 MVA
Equivalent GSU Transformer ¹	Gen 1 Equivalent Qty: 14 X = 8.998 %, R = 0.874 %, Winding MVA = 58.898 MVA, Rating MVA ² = 58.9 MVA
Generator Dynamic Model ³ & Power Factor	14 x PE HEM FP4200M 4.2 MVA (REGCAU1) ³ Leading: 0.8503 Lagging: 0.8503
Reactive Power Devices (Shared with the EGF and unchanged)	1 x 5 MVAR 34.5 Capacitor Bank

1) X and R based on Winding MVA, 2) Rating rounded in PSS/E, 3) DYR stability model name

SPP determined that steady-state analysis was not required because the addition of the SGF does not increase the maximum active power output of 79.96 MW. In addition, the EGF was previously studied at maximum Interconnection Service under all necessary reliability conditions.

The scope of this study included reactive power analysis, short circuit analysis, and dynamic stability analysis.

Aneden performed the analyses using the study data provided for the SGF and the DISIS-2017-002-1 study models:

- 2025 Summer Peak (25SP),
- 2025 Winter Peak (25WP)

All analyses were performed using the Siemens PTI PSS/E² version 34 software and the results are summarized below.

The results of the reactive power analysis using the 25SP model showed that the SGF project did not need a shunt reactor at the project substation to reduce the POI MVAR to zero when the EGF project had a shunt compensating for its charging effects. No additional compensation was necessary to offset the capacitive effect on the transmission network caused by the project during reduced generation conditions. The information gathered from the reactive power analysis is provided as information to the Interconnection Customer and Transmission Owner (TO) and/or Transmission Operator (TOP). The applicable reactive power requirements will be further reviewed by the TO and/or TOP.

² Power System Simulator for Engineering

The short circuit analysis was performed using the 25SP stability model modified for short circuit analysis. The results from the short circuit analysis compared the 25SP model with the EGF online and SGF not connected to the SGF study model (EGF and SGF online). The maximum contribution to three-phase fault currents in the immediate transmission systems due to the addition of the SGF was not greater than 0.14 kA. The maximum three-phase fault current level within 5 buses of the POI with the EGF and SGF generators online was below 28 kA for the 25SP model.

The dynamic stability analysis was performed using Siemens PTI PSS/E version 34.8.0 software for the two modified study models: 25SP and 25WP, each with two dispatch scenarios. 28 events were simulated, which included three-phase faults and single-line-to-ground stuck breaker faults.

- Scenario 1: SGF at maximum assumed dispatch, 50 MW, and EGF disconnected.
- Scenario 2: SGF at maximum assumed dispatch, 50 MW, and EGF dispatched with the remaining 29.96 MW for a total combination of 79.96 MW.

The results of the dynamic stability analysis showed several existing base case issues that were found in both the original DISIS-2017-002-1 model and in the model with GEN-2023-SR9 included. These issues were not attributed to the GEN-2023-SR9 surplus request and are detailed in Appendix C.

There were no damping or voltage recovery violations attributed to the GEN-2023-SR9 surplus request observed during the simulated faults. Additionally, the project was found to stay connected during the contingencies that were studied and, therefore, will meet the Low Voltage Ride Through (LVRT) requirements of FERC Order #661A.

The results of the study showed that the Surplus Interconnection Service Request by GEN-2023-SR9 did not negatively impact the reliability of the Transmission System. There were no additional Interconnection Facilities or Network Upgrades identified by the analyses.

SPP has determined that GEN-2023-SR9 may utilize the requested 50 MW of Surplus Interconnection Service being made available by the EGF. The combined generation from both the SGF and the EGF may not exceed 79.96 MW at the POI.

The customer must install monitoring and control equipment as needed to ensure that the SGF does not exceed the granted surplus amount and to ensure that combination of the SGF and EGF power injected at the POI does not exceed the Interconnection Service amount listed in the EGF's GIA. The monitoring and control scheme may be reviewed by the TO and documented in Appendix C of the SGF GIA.

In accordance with FERC Order No. 827, both the SGF and EGF will be required to provide dynamic reactive power within the range of 0.95 leading to 0.95 lagging at the high-side of the generator substation.

It is likely that the customer may be required to reduce its generation output to 0 MW in real-time, also known as curtailment, under certain system conditions to allow system operators to maintain the reliability of the transmission network.

Nothing in this study should be construed as a guarantee of transmission service or delivery rights. If the customer wishes to obtain deliverability to final customers, a separate request for transmission service must be requested on Southwest Power Pool's OASIS by the customer.

1.0 Scope of Study

Aneden Consulting (Aneden) was retained by the Southwest Power Pool (SPP) to perform a Surplus Service Impact Study (Study) for GEN-2023-SR9, the Surplus Generating Facility (SGF). A Surplus Service Impact Study is performed to identify the impact of the Surplus Interconnection Service on the transmission system reliability and any additional Interconnection Facilities necessary pursuant to the SPP Generator Interconnection Procedures (“GIP”) contained in Attachment V Section 3.3 of the SPP Open Access Transmission Tariff (SPP Tariff). The amount of Surplus Interconnection Service available to the SGF is limited by the amount of Interconnection Service granted to the existing interconnection customer for the Existing Generating Facility (EGF) at the same POI. The Surplus Interconnection Service is only available up to the amount that can be accommodated without requiring additional Network Upgrades except those specified in the SPP Tariff³. The required scope of the study is dependent upon the EGF and SGF specifications. The criteria sections below include the basis of the analyses included in the scope of study.

All analyses were performed using the Siemens PTI PSS/E version 34 software. The results of each analysis are presented in the following sections.

1.1 Reactive Power Analysis

SPP requires that a reactive power analysis be performed on the requested configuration if it is a non-synchronous resource. The reactive power analysis determines the added capacitive effect at the POI caused by the project’s collection system and transmission line’s capacitance. A shunt reactor size was determined for the SGF to offset the capacitive effect and maintain zero (0) MVAR injection at the POI while the plant’s generators and capacitors were offline, and the EGF project had a shunt compensating for its charging effects.

1.2 Short Circuit Analysis

SPP requires that a short circuit analysis be performed to determine the maximum available fault current requiring interruption by protective equipment with both the SGF and EGF online, along with the amount of increase in maximum fault current due to the addition of the SGF. The analysis was performed on two scenarios, with the EGF in service and SGF offline, and the modified model with both EGF and SGF in service.

1.3 Stability Analysis

SPP requires that a dynamic stability analysis be performed to determine whether the SGF, EGF, and the transmission system will remain stable and within applicable criteria. Dynamic stability analysis was performed on two dispatch scenarios, the first where the SGF was online at 100% of the assumed dispatch with the EGF offline and disconnected, and the second where the SGF was online at 100% of the assumed dispatch and the EGF was picking up the remaining EGF GIA capacity. The stability analyses will identify any additional Interconnection Facilities and Network Upgrades necessary.

1.4 Steady-State Analysis

The steady-state (thermal/voltage) analyses may be performed as necessary to ensure that all required reliability conditions are studied. If the EGF was not studied under off-peak conditions, off-peak steady state analyses shall be performed to the required level necessary to demonstrate reliable operation of the Surplus Interconnection Service. If the original system impact study is not available for the

³ Allowed Network Upgrades detailed in SPP Open Access Transmission Tariff Attachment V Section 3.3

Interconnection Service, both off-peak and peak analysis may need to be performed for the EGF associated with the request.

An SGF that includes a fuel type (synchronous/non-synchronous) different from the EGF may require a steady-state analysis to study impacts resultant from changes in dispatch to all equal and lower queued requests. The steady-state analyses will identify any additional Interconnection Facilities and Network Upgrades necessary.

1.5 Necessary Interconnection Facilities & Network Upgrades

The SPP Tariff⁴ states that the reactive power, short circuit/fault duty, stability, and steady-state analyses (where applicable) for the Surplus Interconnection Service will identify any additional Interconnection Facilities necessary. In addition, the analyses will determine if any Network Upgrades are required for mitigation. The Surplus Interconnection Service is only available up to the amount that can be accommodated without requiring additional Network Upgrades except (a) those additional Network Upgrades are either (1) located at the Point of Interconnection substation and at the same voltage level as the Generating Facility with an effective GIA, or (2) are System Protection Facilities; and (b) there are no material adverse impacts on the cost or timing of any Interconnection Requests pending at the time the Surplus Interconnection Service request is submitted

1.6 Study Limitations

The assessments and conclusions provided in this report are based on assumptions and information provided to Aneden by others. While the assumptions and information provided may be appropriate for the purposes of this report, Aneden does not guarantee that those conditions assumed will occur. In addition, Aneden did not independently verify the accuracy or completeness of the information provided. As such, the conclusions and results presented in this report may vary depending on the extent to which actual future conditions differ from the assumptions made or information used herein.

⁴ SPP Open Access Transmission Tariff Section 3.3.4.1

2.0 Surplus Interconnection Service Request

The GEN-2023-SR9 Interconnection Customer has requested a Surplus Interconnection Service Impact Study (Study) for GEN-2023-SR9 to utilize the Surplus Interconnection Service being made available by GEN-2011-025 at its existing Point of Interconnection (POI) on the Floyd County to Crosby County 115 kV line in the Southwestern Public Service (SPS) control area.

GEN-2023-SR9, the proposed SGF, will connect to the existing GEN-2011-025 main collection substation and share its main power transformer.

GEN-2011-025, the EGF, has an effective Generation Interconnection Agreement (GIA) with a POI capacity of 79.96 MW and is making 50 MW of Surplus Interconnection Service available at its point of interconnection. Per the SPP Tariff the amount of Surplus Interconnection Service available to the SGF is limited by the amount of Interconnection Service granted to the EGF at the same POI. In addition, the Surplus Interconnection Service is only available up to the amount that can be accommodated without requiring additional Network Upgrades except those specified in the SPP Tariff.

At the time of the posting of this report, GEN-2011-025 (EGF) is an active existing generator at the same POI with a queue status of “IA FULLY EXECUTED/COMMERCIAL OPERATION”. GEN-2011-025 is a wind farm, has a maximum summer and winter queue capacity of 79.96 MW, and has Energy Resource Interconnection Service (ERIS). The EGF was originally studied in the DISIS-2011-001 cluster study. Figure 2-1 shows the power flow model single line diagram for the EGF configuration.

The proposed SGF configuration consists of 14 x PE HEM FP4200M Battery Energy Storage System (BESS) inverters operating at 3.5714 MW for a total assumed dispatch of 50 MW. The inverters are rated at 4.2 MW, thus the generating capability of the SGF (58.8 MW) exceeds its requested Surplus Interconnection Service of 50 MW. The injection amount of the SGF must be limited to 50 MW at the POI. The combined generation from both the SGF and the EGF may not exceed 79.96 MW at the POI. GEN-2023-SR9 includes the use of a Power Plant Controller (PPC) to limit the power injection as required. The SGF and EGF information is shown in Table 2-1 below.

Table 2-1: EGF & SGF Configuration

Request	Interconnection Queue Capacity (MW)	Fuel Type	Point of Interconnection
GEN-2023-SR9 (SGF)	50	Battery/Storage	Tap on Floyd County 115 kV (525780) to Crosby County 115 kV (525926) (Blanco 115 kV 525803)
GEN-2011-025 (EGF)	79.96	Wind	Tap on Floyd County 115 kV (525780) to Crosby County 115 kV (525926) (Blanco 115 kV 525803)

The proposed detailed SGF configuration is captured in Figure 2-2 and Table 2-2 below.

Figure 2-1: GEN-2011-025 Single Line Diagram (EGF Existing Configuration*)

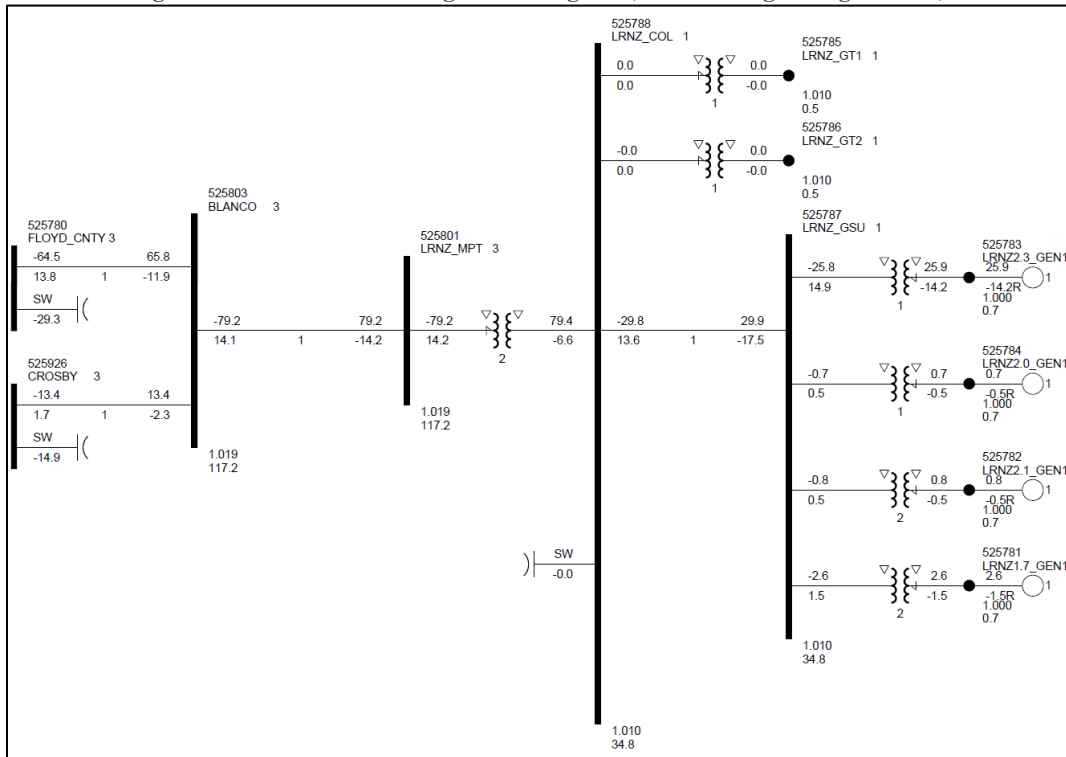

*based on the DISIS-2017-002-1 stability models

Figure 2-2: GEN-2011-025 & GEN-2023-SR9 Single Line Diagram (EGF & SGF Configuration)

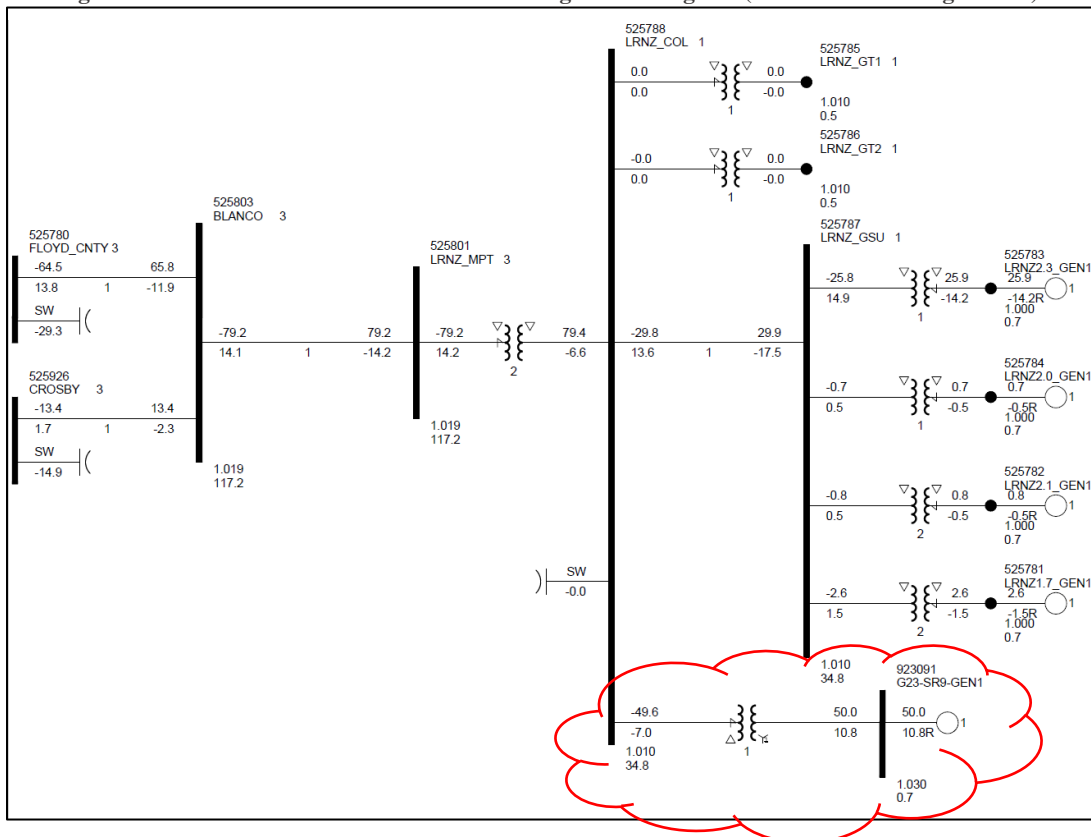

Table 2-2: SGF Interconnection Configuration

Facility	SGF Configuration
Point of Interconnection	Tap on Floyd County 115 kV (525780) to Crosby County 115 kV (525926) (Blanco 115 kV 525803)
Configuration/Capacity	14 x PE HEM FP4200M operating at 3.5714 MW (BESS) = 50 MW [dispatch] Units are rated at 4.2 MW, PPC to limit GEN-2023-SR9 to 50 MW at the POI and total POI injection w/ GEN-2011-025 to 79.96 MW
Generation Interconnection Line (Shared with the EGF and unchanged)	Length = 0.01 miles R = 0.000010 pu X = 0.000020 pu B = 0.000200 pu Rating MVA = 0 MVA
Main Substation Transformer ¹ (Shared with the EGF and unchanged)	X = 6.947%, R = 0.211%, Winding MVA = 57.4 MVA, Rating A/B/C MVA = 57/76/96 MVA
Equivalent GSU Transformer ¹	Gen 1 Equivalent Qty: 14 X = 8.998 %, R = 0.874 %, Winding MVA = 58.898 MVA, Rating MVA ² = 58.9 MVA
Generator Dynamic Model ³ & Power Factor	14 x PE HEM FP4200M 4.2 MVA (REGCAU1) ³ Leading: 0.8503 Lagging: 0.8503
Reactive Power Devices (Shared with the EGF and unchanged)	1 x 5 MVAR 34.5 Capacitor Bank

1) X and R based on Winding MVA, 2) Rating rounded in PSS/E, 3) DYR stability model name

3.0 Reactive Power Analysis

The reactive power analysis was performed for GEN-2023-SR9 to determine the capacitive charging effects due to the SGF during reduced generation conditions (unsuitable wind speeds, unsuitable solar irradiance, insufficient state of charge, idle conditions, curtailment, etc.) at the generation site, and to size shunt reactors that would reduce the project reactive power contribution to the POI to approximately zero.

3.1 Methodology and Criteria

In order to determine the required shunt reactor the SGF would need to compensate for the current charging attributed to its collection system, the reactive power analysis for the EGF was determined first. Once the shunt size for the EGF was determined, the SGF incremental shunt reactor size was then calculated.

For each of the shunt reactor sizes calculated, all project generators and capacitors were switched offline while other collector system elements remained in-service. For the SGF reactor size calculation, the EGF generators were also switched offline. A shunt reactor was tested at the project's collection substation 34.5 kV bus to set the MVAR flow into the POI to approximately zero. The size of the shunt reactor is equivalent to the charging current value at unity voltage and the compensation provided is proportional to the voltage effects on the charging current (i.e., for voltages above unity, reactive compensation is greater than the size of the reactor).

Aneden performed the reactive power analysis using the SGF data based on the 25SP DISIS-2017-002-1 stability study model.

3.2 Results

Per the methodology described above, the shunt size was determined for the EGF prior to calculating the shunt reactor size for the SGF. The shunt size was found to be a 3.92 MVAR reactor for the EGF to reduce the POI MVAR to approximately zero.

The results from the analysis showed that the SGF did not need a shunt reactor at the project substation to reduce the POI MVAR to zero with the pre-determined shunt for the EGF in-service. Figure 3-1 illustrates that no additional compensation was necessary to offset the capacitive effect on the transmission network caused by the project during reduced generation conditions.

The information gathered from the reactive power analysis is provided as information to the Interconnection Customer and Transmission Owner (TO) and/or Transmission Operator (TOP). The applicable reactive power requirements will be further reviewed by the TO and/or TOP.

Figure 3-1: GEN-2023-SR9 Single Line Diagram (Shunt Sizes)

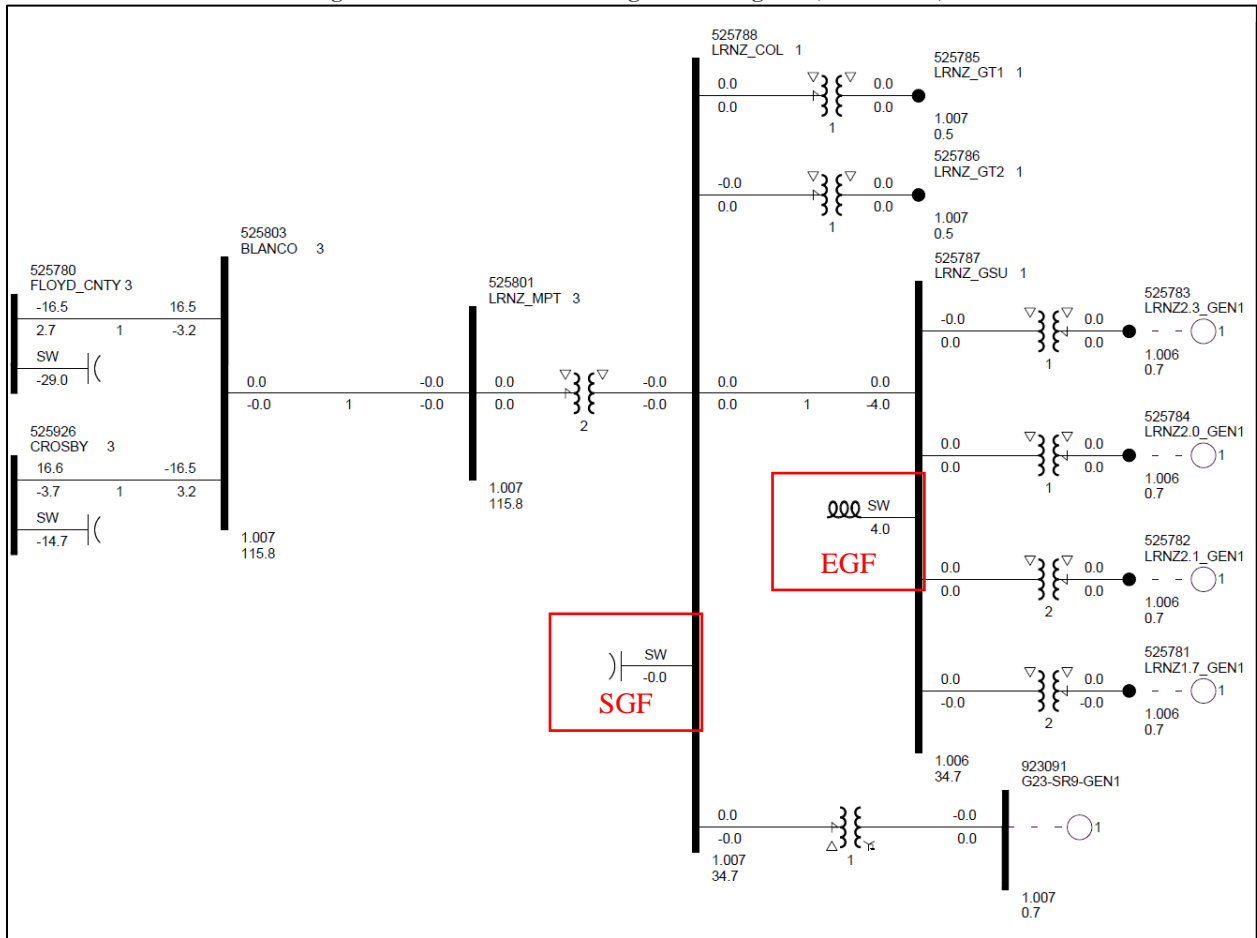

4.0 Short Circuit Analysis

A short circuit study was performed using the 25SP model to determine the maximum available fault current requiring interruption by protective equipment with both the SGF and EGF online for each bus in the relevant subsystem, and the amount of increase in maximum fault current due to the addition of the SGF. The detailed results of the short circuit analysis are provided in Appendix B.

4.1 Methodology

The short circuit analysis included applying a 3-phase fault on buses up to 5 levels away from the 115 kV POI bus. The PSS/E “Automatic Sequence Fault Calculation (ASCC)” fault analysis module was used to calculate the fault current levels in the transmission system with and without the SGF online. The first scenario was studied with both the SGF and EGF in service. In the second scenario the SGF was disconnected while the EGF stayed online in order to determine the impact of the SGF.

Aneden created a short circuit model using the 25SP DISIS-2017-002-1 stability study model by adjusting the SGF short circuit parameters consistent with the submitted data. The adjusted parameters used in the short circuit analysis are shown in Table 4-1 below.

Table 4-1: Short Circuit Model Parameters*

Parameter	Value by Generator Bus#
	923091
Machine MVA Base	58.8
R (pu)	0.0
X'' (pu)	0.893

*pu values based on Machine MVA Base

4.2 Results

The results of the short circuit analysis compared the 25SP model with the EGF online and SGF not connected to the stability Scenario 2 dispatch model with both the EGF and SGF in service as described in Section 5.1. The GEN-2023-SR9 POI bus (Blanco 115 kV - 525803) fault current magnitudes for the comparison cases are provided in Table 4-2 showing a fault current of 6 kA with the EGF and SGF online. The addition of the SGF configuration increased the POI bus fault current by 0.14 kA. Table 4-3 shows the maximum fault current magnitudes and fault current increases with the SGF project online.

The maximum fault current calculated within 5 buses of the POI was less than 28 kA for the 25SP model. The maximum contribution to three-phase fault currents due to the addition of the SGF was about 2.4% and 0.14 kA.

Table 4-2: POI Short Circuit Comparison Results

Case	EGF Only Current (kA)	SGF & EGF Current (kA)	kA Change	%Change
25SP	5.86	6.00	0.14	2.4%

Table 4-3: 25SP Short Circuit Comparison Results

Voltage (kV)	Max. Current (EGF & SGF) (kA)	Max kA Change	Max %Change
69	8.0	0.04	0.7%
115	19.6	0.14	2.4%
230	27.4	0.02	0.1%
345	12.6	0.00	0.0%
Max	27.4	0.14	2.4%

5.0 Dynamic Stability Analysis

Aneden performed a dynamic stability analysis to identify the impact of the SGF project. The analysis was performed according to SPP's Disturbance Performance Requirements⁵. The project details are described in Section 2.0 above and the dynamic modeling data is provided in Appendix A. The existing base case issues and simulation plots can be found in Appendix C.

5.1 Methodology and Criteria

The dynamic stability analysis was performed using models developed with the requested 14 x PE HEM FP4200M 3.5714 MW (REGCAU1) SGF generating facility configuration included in the models. This stability analysis was performed using Siemens PTI's PSS/E version 34.8.0 software.

Two stability model scenarios were developed using the models from DISIS-2017-002-1. The first scenario (Scenario 1) was comprised of the SGF online at 100% of the assumed dispatch (SGF = 50 MW) while the EGF generator was offline and disconnected. The second scenario (Scenario 2) was comprised of the SGF online at 100% of the assumed dispatch (SGF = 50 MW) while the EGF was picking up the remaining EGF GIA capacity (EGF = 29.96 MW). The study scenarios are shown in Table 5-1.

Table 5-1: Study Scenarios (Generator Dispatch MW)

Scenario	GEN-2011-025 EGF (MW)	GEN-2023-SR9 SGF (MW)	EGF + SGF (MW)
1	0 (Offline)	50	50
2	29.96	50	79.96

The GEN-2023-SR9 project details were used to create modified stability models for this impact study based on the DISIS-2017-002-1 stability study models:

- 2025 Summer Peak (25SP),
- 2025 Winter Peak (25WP)

The dynamic model data for the GEN-2023-SR9 project is provided in Appendix A. The power flow models and associated dynamic database were initialized (no-fault test) to confirm that there were no errors in the initial conditions of the system and the dynamic data.

The following system adjustments were made to address existing base case issues that are not attributed to the surplus request:

- The frequency protective relays at bus 579433 were disabled after observing the generator tripping during initial three phase fault simulations. This frequency tripping issue is a known PSS/E limitation when calculating bus frequency as it relates to non-conventional type devices.
- The voltage protective relays at buses 761442, 761445, 761449, 761447, and 579433 were disabled to avoid generator tripping due to an instantaneous over voltage spike after fault clearing.

⁵ [SPP Disturbance Performance Requirements:](https://www.spp.org/documents/28859/spp%20disturbance%20performance%20requirements%20(twg%20approved).pdf)

[https://www.spp.org/documents/28859/spp%20disturbance%20performance%20requirements%20\(twg%20approved\).pdf](https://www.spp.org/documents/28859/spp%20disturbance%20performance%20requirements%20(twg%20approved).pdf)

- The fault simulation file acceleration factor was reduced as needed to resolve stability simulation crashes.

During the fault simulations, the active power (PELEC), reactive power (QELEC), and terminal voltage (ETERM) were monitored for the EGF and SGF and other current and prior queued projects in their cluster group⁶. In addition, voltages of five (5) buses away from the POI of the SGF were monitored and plotted. The machine rotor angle for synchronous machines and speed for asynchronous machines within the study areas including 520 (AEPW), 524 (OKGE), 526 (SPS), and 652 (WAPA) were monitored. The voltages of all 100 kV and above buses within the study area were monitored as well.

5.2 Fault Definitions

Aneden developed and simulated fault events as required to study the SGF. The new set of faults was simulated using the modified study models. The fault events included three-phase faults and single-line-to-ground stuck breaker faults. Single-line-to-ground faults are approximated by applying a fault impedance to bring the faulted bus positive sequence voltage to 0.6 pu. The simulated faults are listed and described in Table 5-2 below. These contingencies were applied to the modified 25SP and 25WP models.

Table 5-2: Fault Definitions

Fault ID	Planning Event	Fault Descriptions
FLT9001-3PH	P1	3 phase fault on the BLANCO 3 (525803) to CROSBY 3 (525926) 115 kV line CKT 1, near BLANCO 3. a. Apply fault at the BLANCO 3 115 kV bus. b. Clear fault after 7 cycles by tripping the faulted line. c. Wait 20 cycles, and then re-close the line in (b) back into the fault. d. Leave fault on for 7 cycles, then trip the line in (b) and remove fault.
FLT9002-3PH	P1	3 phase fault on the BLANCO 3 (525803) to FLOYD_CNTY 3 (525780) 115 kV line CKT 1, near BLANCO 3. a. Apply fault at the BLANCO 3 115 kV bus. b. Clear fault after 7 cycles by tripping the faulted line. c. Wait 20 cycles, and then re-close the line in (b) back into the fault. d. Leave fault on for 7 cycles, then trip the line in (b) and remove fault.
FLT9003-3PH	P1	3 phase fault on the VON 13867-1 115 kV (525926) /69 kV (525925) /13.2 kV (525923) XFMR CKT 1, near CROSBY 3 115 kV. a. Apply fault at the CROSBY 3 115 kV bus. b. Clear fault after 7 cycles and trip the faulted transformer.
FLT9004-3PH	P1	3 phase fault on the CROSBY 3 (525926) to LUBBCK_EST 3 (526298) 115 kV line CKT 1, near CROSBY 3. a. Apply fault at the CROSBY 3 115 kV bus. b. Clear fault after 7 cycles by tripping the faulted line. c. Wait 20 cycles, and then re-close the line in (b) back into the fault. d. Leave fault on for 7 cycles, then trip the line in (b) and remove fault.
FLT9005-3PH	P1	3 phase fault on the LUBBCK_EST 3 (526298) to LUBBCK_STH 3 (526268) 115 kV line CKT 1, near LUBBCK_EST 3. a. Apply fault at the LUBBCK_EST 3 115 kV bus. b. Clear fault after 7 cycles by tripping the faulted line. c. Wait 20 cycles, and then re-close the line in (b) back into the fault. d. Leave fault on for 7 cycles, then trip the line in (b) and remove fault.
FLT9006-3PH	P1	3 phase fault on the ENRCO 136712 115 kV (526298) /69 kV (526297) /13.2 kV (526295) XFMR CKT 1, near LUBBCK_EST 3 115 kV. a. Apply fault at the LUBBCK_EST 3 115 kV bus. b. Clear fault after 7 cycles and trip the faulted transformer.

⁶ Based on the DISIS-2017-002 Cluster Groups

Table 5-2 Continued

Fault ID	Planning Event	Fault Descriptions
FLT9007-3PH	P1	3 phase fault on the LUBBCK_EST 3 (526298) to TUCO_INT 3 (525828) 115 kV line CKT 1, near LUBBCK_EST 3. a. Apply fault at the LUBBCK_EST 3 115 kV bus. b. Clear fault after 7 cycles by tripping the faulted line. c. Wait 20 cycles, and then re-close the line in (b) back into the fault. d. Leave fault on for 7 cycles, then trip the line in (b) and remove fault.
FLT9008-3PH	P1	3 phase fault on the ENRCO 136162 115 kV (526298) /230 kV (526299) /13.2 kV (526294) XFMR CKT 1, near LUBBCK_EST 3 115 kV. a. Apply fault at the LUBBCK_EST 3 115kV bus. b. Clear fault after 7 cycles and trip the faulted transformer.
FLT9009-3PH	P1	3 phase fault on the FLOYD_CNTY 3 (525780) to CALLAHAN 3 (525763) 115 kV line CKT 1, near FLOYD_CNTY 3. a. Apply fault at the FLOYD_CNTY 3 115 kV bus. b. Clear fault after 7 cycles by tripping the faulted line. c. Wait 20 cycles, and then re-close the line in (b) back into the fault. d. Leave fault on for 7 cycles, then trip the line in (b) and remove fault.
FLT9010-3PH	P1	3 phase fault on the FLOYD_CNTY 3 (525780) to TUCO_INT 3 (525828) 115 kV line CKT 1, near FLOYD_CNTY 3. a. Apply fault at the FLOYD_CNTY 3 115 kV bus. b. Clear fault after 7 cycles by tripping the faulted line. c. Wait 20 cycles, and then re-close the line in (b) back into the fault. d. Leave fault on for 7 cycles, then trip the line in (b) and remove fault.
FLT9011-3PH	P1	3 phase fault on the ENRCO 136711 115 kV (525780) /69 kV (525779) /13.2 kV (525777) XFMR CKT 1, near FLOYD_CNTY 3 115 kV. a. Apply fault at the FLOYD_CNTY 3 115 kV bus. b. Clear fault after 7 cycles and trip the faulted transformer.
FLT9012-3PH	P1	3 phase fault on the CALLAHAN 3 (525763) to COX 3 (525326) 115 kV line CKT 1, near CALLAHAN 3. a. Apply fault at the CALLAHAN 3 115 kV bus. b. Clear fault after 7 cycles by tripping the faulted line. c. Wait 20 cycles, and then re-close the line in (b) back into the fault. d. Leave fault on for 7 cycles, then trip the line in (b) and remove fault.
FLT9013-3PH	P1	3 phase fault on the GE M102345 115 kV (525828) /230 kV (525830) /13.2 kV (525821) XFMR CKT 1, near TUCO_INT 3 115 kV. a. Apply fault at the TUCO_INT 3 115kV bus. b. Clear fault after 7 cycles and trip the faulted transformer.
FLT9014-3PH	P1	3 phase fault on the NA 70430B 115 kV (525828) /69 kV (525826) /13.2 kV (525823) XFMR CKT 1, near TUCO_INT 3 115 kV. a. Apply fault at the TUCO_INT 3 115kV bus. b. Clear fault after 7 cycles and trip the faulted transformer.
FLT9015-3PH	P1	3 phase fault on the DS F78800913 115 kV (525828) /69 kV (525816) /13.2 kV (525814) XFMR CKT 1, near TUCO_INT 3 115 kV. a. Apply fault at the TUCO_INT 3 115kV bus. b. Clear fault after 7 cycles and trip the faulted transformer.
FLT9016-3PH	P1	3 phase fault on the TUCO_INT 3 (525828) to HALE_CNTY 3 (525454) 115 kV line CKT 1, near TUCO_INT 3. a. Apply fault at the TUCO_INT 3 115 kV bus. b. Clear fault after 7 cycles by tripping the faulted line. c. Wait 20 cycles, and then re-close the line in (b) back into the fault. d. Leave fault on for 7 cycles, then trip the line in (b) and remove fault.
FLT9017-3PH	P1	3 phase fault on the TUCO_INT 3 (525828) to STANTON_W 3 (526076) 115 kV line CKT 1, near TUCO_INT 3. a. Apply fault at the TUCO_INT 3 115 kV bus. b. Clear fault after 7 cycles by tripping the faulted line. c. Wait 20 cycles, and then re-close the line in (b) back into the fault. d. Leave fault on for 7 cycles, then trip the line in (b) and remove fault.

Table 5-2 Continued

Fault ID	Planning Event	Fault Descriptions
FLT9018-3PH	P1	3 phase fault on the LUBBCK_EST 6 (526299) to JONES 6 (526337) 230 kV line CKT 1, near LUBBCK_EST 6. a. Apply fault at the LUBBCK_EST 6 230 kV bus. b. Clear fault after 7 cycles by tripping the faulted line. c. Wait 20 cycles, and then re-close the line in (b) back into the fault. d. Leave fault on for 7 cycles, then trip the line in (b) and remove fault.
FLT9019-3PH	P1	3 phase fault on the TUCO 230 kV (525830) /345 kV (525832) /13.2 kV (525824) XFMR CKT 1, near TUCO_INT 6 230 kV. a. Apply fault at the TUCO_INT 6 230 kV bus. b. Clear fault after 7 cycles and trip the faulted transformer.
FLT9020-3PH	P1	3 phase fault on the TUCO 230 kV (525830) /13 kV (525820) XFMR CKT 1, near TUCO_INT 6 230 kV. a. Apply fault at the TUCO_INT 6 230 kV bus. b. Clear fault after 7 cycles and trip the faulted transformer. Trip generator TUCO_SVC 1 (525820).
FLT9021-3PH	P1	3 phase fault on the TUCO_INT 6 (525830) to TOLK 6 (525531) 230 kV line CKT 1, near TUCO_INT 6. a. Apply fault at the TUCO_INT 6 230 kV bus. b. Clear fault after 7 cycles by tripping the faulted line. c. Wait 20 cycles, and then re-close the line in (b) back into the fault. d. Leave fault on for 7 cycles, then trip the line in (b) and remove fault.
FLT9022-3PH	P1	3 phase fault on the TUCO_INT 6 (525830) to HALE_WNDCL16 (525957) 230 kV line CKT 1, near TUCO_INT 6. a. Apply fault at the TUCO_INT 6 230 kV bus. b. Clear fault after 7 cycles by tripping the faulted line. Trip generator on bus HALE_WNDG1 10.7000 (525951) Trip generator on bus HALE_WNDG2 10.7000 (525952) Trip generator on bus HALE_WNDG3 10.7000 (525953) c. Wait 20 cycles, and then re-close the line in (b) back into the fault. d. Leave fault on for 7 cycles, then trip the line in (b) and remove fault.
FLT9023-3PH	P1	3 phase fault on the TUCO_INT 6 (525830) to ANTELOPE_1 6 (525840) 230 kV line CKT 1, near TUCO_INT 6. a. Apply fault at the TUCO_INT 6 230 kV bus. b. Clear fault after 7 cycles by tripping the faulted line. c. Wait 20 cycles, and then re-close the line in (b) back into the fault. d. Leave fault on for 7 cycles, then trip the line in (b) and remove fault.
FLT9024-3PH	P1	3 phase fault on the TUCO_INT 6 (525830) to SWISHER 6 (525213) 230 kV line CKT 1, near TUCO_INT 6. a. Apply fault at the TUCO_INT 6 230 kV bus. b. Clear fault after 7 cycles by tripping the faulted line. c. Wait 20 cycles, and then re-close the line in (b) back into the fault. d. Leave fault on for 7 cycles, then trip the line in (b) and remove fault.
FLT9025-3PH	P1	3 phase fault on the TUCO_INT 6 (525830) to CARLISLE 6 (526161) 230 kV line CKT 1, near TUCO_INT 6. a. Apply fault at the TUCO_INT 6 230 kV bus. b. Clear fault after 7 cycles by tripping the faulted line. c. Wait 20 cycles, and then re-close the line in (b) back into the fault. d. Leave fault on for 7 cycles, then trip the line in (b) and remove fault.
FLT9026-3PH	P1	3 phase fault on the TUCO_INT 6 (525830) to JOHNS 6 (526337) 230 kV line CKT 1, near TUCO_INT 6. a. Apply fault at the TUCO_INT 6 230 kV bus. b. Clear fault after 7 cycles by tripping the faulted line. c. Wait 20 cycles, and then re-close the line in (b) back into the fault. d. Leave fault on for 7 cycles, then trip the line in (b) and remove fault.
FLT1001-SB	P4	Stuck Breaker at FLOYD_CNTY 3 (525780) 115 kV bus a. Apply single phase fault at FLOYD_CNTY 3 bus. b. Clear fault after 16 cycles and trip the following elements c. Trip the Bus FLOYD_CNTY 3 (525780).
FLT1002-SB	P4	Stuck Breaker at CROSBY 3 (525926) 115 kV bus a. Apply single phase fault at CROSBY 3 bus. b. Clear fault after 16 cycles and trip the following elements c. Trip the Bus CROSBY 3 (525926). Trip generator on bus PLSNTHLLWND10.7000 (525910) Trip generator on bus A11-003-GEN10.6900 (579433)

5.3 Scenario 1 Results

Table 5-3 shows the relevant results of the fault events simulated for each of the modified models in Scenario 1. Existing DISIS base case issues are documented separately in Appendix C. The associated stability plots are also provided in Appendix C.

Table 5-3: Scenario 1 Dynamic Stability Results (EGF = 0 MW, SGF = 50 MW)

Fault ID	25SP			25WP		
	Voltage Violation	Voltage Recovery	Stable	Voltage Violation	Voltage Recovery	Stable
FLT9001-3PH	Pass	Pass	Stable	Pass	Pass	Stable
FLT9002-3PH	Pass	Pass	Stable	Pass	Pass	Stable
FLT9003-3PH	Pass	Pass	Stable	Pass	Pass	Stable
FLT9004-3PH	Pass	Pass	Stable	Pass	Pass	Stable
FLT9005-3PH	Pass	Pass	Stable	Pass	Pass	Stable
FLT9006-3PH	Pass	Pass	Stable	Pass	Pass	Stable
FLT9007-3PH	Pass	Pass	Stable	Pass	Pass	Stable
FLT9008-3PH	Pass	Pass	Stable	Pass	Pass	Stable
FLT9009-3PH	Pass	Pass	Stable	Pass	Pass	Stable
FLT9010-3PH	Pass	Pass	Stable	Pass	Pass	Stable
FLT9011-3PH	Pass	Pass	Stable	Pass	Pass	Stable
FLT9012-3PH	Pass	Pass	Stable	Pass	Pass	Stable
FLT9013-3PH	Pass	Pass	Stable	Pass	Pass	Stable
FLT9014-3PH	Pass	Pass	Stable	Pass	Pass	Stable
FLT9015-3PH	Pass	Pass	Stable	Pass	Pass	Stable
FLT9016-3PH	Pass	Pass	Stable	Pass	Pass	Stable
FLT9017-3PH	Pass	Pass	Stable	Pass	Pass	Stable
FLT9018-3PH	Pass	Pass	Stable	Pass	Pass	Stable
FLT9019-3PH	Pass	Pass	Stable	Pass	Pass	Stable
FLT9020-3PH	Pass	Pass	Stable	Pass	Pass	Stable
FLT9021-3PH	Pass	Pass	Stable	Pass	Pass	Stable
FLT9022-3PH	Pass	Pass	Stable	Pass	Pass	Stable
FLT9023-3PH	Pass	Pass	Stable	Pass	Pass	Stable
FLT9024-3PH	Pass	Pass	Stable	Pass	Pass	Stable
FLT9025-3PH	Pass	Pass	Stable	Pass	Pass	Stable
FLT9026-3PH	Pass	Pass	Stable	Pass	Pass	Stable
FLT1001-SB	Pass	Pass	Stable	Pass	Pass	Stable
FLT1002-SB	Pass	Pass	Stable	Pass	Pass	Stable

The results of the Scenario 1 dynamic stability showed several existing base case issues that were found in both the original DISIS-2017-002-1 model and the model with GEN-2023-SR9 included. These issues were not attributed to the GEN-2023-SR9 surplus request and detailed in Appendix C.

There were no damping or voltage recovery violations attributed to the GEN-2023-SR9 surplus request observed during the simulated faults. Additionally, the project was found to stay connected during the contingencies that were studied and, therefore, will meet the Low Voltage Ride Through (LVRT) requirements of FERC Order #661A.

5.4 Scenario 2 Results

Table 5-4 shows the relevant results of the fault events simulated for each of the modified models in Scenario 2. Existing DISIS base case issues are documented separately in Appendix C. The associated stability plots are also provided in Appendix C.

Table 5-4: Scenario 2 Dynamic Stability Results (EGF = 29.96 MW, SGF = 50 MW)

Fault ID	25SP			25WP		
	Voltage Violation	Voltage Recovery	Stable	Voltage Violation	Voltage Recovery	Stable
FLT9001-3PH	Pass	Pass	Stable	Pass	Pass	Stable
FLT9002-3PH	Pass	Pass	Stable	Pass	Pass	Stable
FLT9003-3PH	Pass	Pass	Stable	Pass	Pass	Stable
FLT9004-3PH	Pass	Pass	Stable	Pass	Pass	Stable
FLT9005-3PH	Pass	Pass	Stable	Pass	Pass	Stable
FLT9006-3PH	Pass	Pass	Stable	Pass	Pass	Stable
FLT9007-3PH	Pass	Pass	Stable	Pass	Pass	Stable
FLT9008-3PH	Pass	Pass	Stable	Pass	Pass	Stable
FLT9009-3PH	Pass	Pass	Stable	Pass	Pass	Stable
FLT9010-3PH	Pass	Pass	Stable	Pass	Pass	Stable
FLT9011-3PH	Pass	Pass	Stable	Pass	Pass	Stable
FLT9012-3PH	Pass	Pass	Stable	Pass	Pass	Stable
FLT9013-3PH	Pass	Pass	Stable	Pass	Pass	Stable
FLT9014-3PH	Pass	Pass	Stable	Pass	Pass	Stable
FLT9015-3PH	Pass	Pass	Stable	Pass	Pass	Stable
FLT9016-3PH	Pass	Pass	Stable	Pass	Pass	Stable
FLT9017-3PH	Pass	Pass	Stable	Pass	Pass	Stable
FLT9018-3PH	Pass	Pass	Stable	Pass	Pass	Stable
FLT9019-3PH	Pass	Pass	Stable	Pass	Pass	Stable
FLT9020-3PH	Pass	Pass	Stable	Pass	Pass	Stable
FLT9021-3PH	Pass	Pass	Stable	Pass	Pass	Stable
FLT9022-3PH	Pass	Pass	Stable	Pass	Pass	Stable
FLT9023-3PH	Pass	Pass	Stable	Pass	Pass	Stable
FLT9024-3PH	Pass	Pass	Stable	Pass	Pass	Stable
FLT9025-3PH	Pass	Pass	Stable	Pass	Pass	Stable
FLT9026-3PH	Pass	Pass	Stable	Pass	Pass	Stable
FLT1001-SB	Pass	Pass	Stable	Pass	Pass	Stable
FLT1002-SB	Pass	Pass	Stable	Pass	Pass	Stable

The results of the Scenario 2 dynamic stability showed several existing base case issues that were found in both the original DISIS-2017-002-1 model and the model with GEN-2023-SR9 included. These issues were not attributed to the GEN-2023-SR9 surplus request and detailed in Appendix C.

There were no damping or voltage recovery violations attributed to the GEN-2023-SR9 surplus request observed during the simulated faults. Additionally, the project was found to stay connected during the contingencies that were studied and, therefore, will meet the Low Voltage Ride Through (LVRT) requirements of FERC Order #661A.

6.0 Necessary Interconnection Facilities and Network Upgrades

This study identified the impact of the Surplus Interconnection Service on the transmission system reliability and any additional Interconnection Facilities or Network Upgrades necessary. The Surplus Interconnection Service is only available up to the amount that can be accommodated without requiring additional Network Upgrades except (a) those additional Network Upgrades are either (1) located at the Point of Interconnection substation and at the same voltage level as the Generating Facility with an effective GIA, or (2) are System Protection Facilities; and (b) there are no material adverse impacts on the cost or timing of any Interconnection Requests pending at the time the Surplus Interconnection Service request is submitted.

6.1 Interconnection Facilities

This study did not identify any additional Interconnection Facilities required by the addition of the SGF.

6.2 Network Upgrades

This study did not identify any Network Upgrades required by the addition of the SGF. SPP will reach out to the TO and/or TOP to determine if there are any additional Network Upgrades that are either (1) located at the Point of Interconnection substation and at the same voltage level as the Generating Facility with an effective GIA, or (2) are System Protection Facilities.

7.0 Surplus Interconnection Service Determination and Requirements

In accordance with Attachment V of the SPP Tariff, SPP shall evaluate the request for Surplus Interconnection Service and inform the Interconnection Customer in writing of whether the Surplus Interconnection Service can be utilized without negatively impacting the reliability of the Transmission System and without any additional Network Upgrades except those specified in the SPP Tariff.

7.1 Surplus Service Determination

SPP determined the request for Surplus Interconnection Service does not negatively impact the reliability of the Transmission System and no required Network Upgrades or Interconnection Facilities were identified by this Surplus Interconnection Service Impact Study performed by Aneden. Aneden evaluated the impact of the requested Surplus Interconnection Service on the prior study results and determined that the requested Surplus Interconnection Service resulted in similar dynamic stability and short circuit analyses and that the prior study steady-state results are not negatively impacted.

SPP has determined that GEN-2023-SR9 may utilize the requested 50 MW of Surplus Interconnection Service being made available by GEN-2011-025.

7.2 Surplus Service Requirements

The amount of Surplus Interconnection Service available to be used is limited by the amount of Interconnection Service granted to the existing interconnection customer at the same POI. The combined generation from both the SGF and the EGF may not exceed 79.96 MW at the POI, which is the total Interconnection Service amount currently granted to the EGF.

The customer must install monitoring and control equipment as needed to ensure that the SGF does not exceed the granted surplus amount and to ensure that combination of the SGF and EGF power injected at the POI does not exceed the Interconnection Service amount listed in the EGF's GIA. The monitoring and control scheme may be reviewed by the TO and documented in Appendix C of the SGF GIA.

SPP will reach out to the TO and/or TOP to determine if there are any additional Network Upgrades that are either (1) located at the Point of Interconnection substation and at the same voltage level as the Generating Facility with an effective GIA, or (2) are System Protection Facilities.