



**INTERCONNECTION
FACILITIES STUDY
REPORT**

GEN-2017-033

Published December 2021

By SPP Generator Interconnections Dept.

REVISION HISTORY

DATE OR VERSION NUMBER	AUTHOR	CHANGE DESCRIPTION
12/01/2021	SPP	Initial draft report issued.
12/17/2021	SPP	Final report issued.

CONTENTS

Revision History.....	i
Summary.....	1
Introduction	1
Phase(s) of Interconnection Service.....	1
Compensation for Amounts Advanced for Network Upgrade(s).....	1
Interconnection Customer Interconnection Facilities	2
Transmission Owner Interconnection Facilities and Non-Shared Network Upgrade(s)	3
Shared Network Upgrade(s).....	4
Contingent Network Upgrade(s).....	5
Affected System Upgrade(s)	6
Conclusion.....	7
Appendices.....	8
A: Transmission Owner’s Interconnection Facilities Study Report and Network Upgrades Report(s).....	9

SUMMARY

INTRODUCTION

This Interconnection Facilities Study (IFS) for Interconnection Request GEN-2017-033 is for a 200 MW generating facility located in Wilbarger County, TX. The Interconnection Request was studied in the DISIS-2017-001 Impact Study and the DISIS-2017-001-1 Impact Restudy for Network Resource Interconnection Service (NRIS). The Interconnection Customer's requested in-service date is December 31, 2023.

The interconnecting Transmission Owner, American Electric Power (AEP), performed a detailed IFS at the request of SPP. The full report is included in Appendix A. SPP has determined that full Interconnection Service will be available after the assigned Transmission Owner Interconnection Facilities (TOIF), Non-Shared Network Upgrades, Shared Network Upgrades, Contingent Network Upgrades, and Affected System Upgrades that are required for full interconnection service are completed.

The primary objective of the IFS is to identify necessary Transmission Owner Interconnection Facilities, Network Upgrades, other direct assigned upgrades, cost estimates, and associated upgrade lead times needed to grant the requested Interconnection Service.

PHASE(S) OF INTERCONNECTION SERVICE

It is not expected that Interconnection Service will occur in phases. However, full Interconnection Service will not be available until all Interconnection Facilities and Network Upgrade(s) can be placed in service.

COMPENSATION FOR AMOUNTS ADVANCED FOR NETWORK UPGRADE(S)

FERC Order ER20-1687-000 eliminated the use of Attachment Z2 revenue crediting as an option for compensation. The Incremental Long Term Congestion Right (ILTCR) process will be the sole process to compensate upgrade sponsors as of July 1st, 2020.

INTERCONNECTION CUSTOMER INTERCONNECTION FACILITIES

The Generating Facility is proposed to consist of eighty (80) G.E. 2.52-116 2.5 MW Wind Turbine Generator for a total generating nameplate capacity of 200 MW.

The Interconnection Customer's Interconnection Facilities to be designed, procured, constructed, installed, maintained, and owned by the Interconnection Customer at its sole expense include:

- 34.5 kV underground cable collection circuits;
- 34.5 kV to 345 kV transformation substation with associated 34.5 kV and 345 kV switchgear;
- Two 345/34.5 kV 80/107/133 MVA (ONAN/ONAF/ONAF) step-up transformer to be owned and maintained by the Interconnection Customer at the Interconnection Customer's substation;
- An approximately 26.5 mile overhead mile overhead kV line to connect the Interconnection Customer's substation to the Point of Interconnection ("POI") at the 345 kV bus at existing Transmission Owner substation ("Oklaunion 345kV Substation") that is owned and maintained by Transmission Owner;
- All transmission facilities required to connect the Interconnection Customer's substation to the POI;
- Equipment at the Interconnection Customer's substation necessary to maintain a composite power delivery at continuous rated power output at the high-side of the generator substation at a power factor within the range of 95% lagging and 95% leading in accordance with Federal Energy Regulatory Commission (FERC) Order 827. The Interconnection Customer may use inverter manufacturing options for providing reactive power under no/reduced generation conditions. The Interconnection Customer will be required to provide documentation and design specifications demonstrating how the requirements are met; and,
- All necessary relay, protection, control and communication systems required to protect Interconnection Customer's Interconnection Facilities and Generating Facilities and coordinate with Transmission Owner's relay, protection, control and communication systems.

TRANSMISSION OWNER INTERCONNECTION FACILITIES AND NON-SHARED NETWORK UPGRADE(S)

To facilitate interconnection, the interconnecting Transmission Owner will perform work as shown below necessary for the acceptance of the Interconnection Customer’s Interconnection Facilities.

Table 1 and **Table 2** lists the Interconnection Customer’s estimated cost responsibility for Transmission Owner Interconnection Facilities (TOIF) and Non-Shared Network Upgrade(s) and provides an estimated lead time for completion of construction. The estimated lead time begins when the Generator Interconnection Agreement has been fully executed.

Table 1: Transmission Owner Interconnection Facilities (TOIF)

Transmission Owner Interconnection Facilities (TOIF)	Total Cost Estimate (\$)	Allocated Percent (%)	Allocated Cost Estimate (\$)	Estimated Lead Time
<u>Oklaunion 345 kV Substation GEN-2017-033 Interconnection (TOIF) (AEPW) (132982)</u> : Construct one (1) 345 kV line terminal, line switches, dead end structure, line relaying, communications, revenue metering, line arrestor, and all associated equipment and facilities necessary to accept transmission line from Interconnection Customer’s Generating Facility.	\$1,436,587	100%	\$1,436,587	24 Months
Total	\$1,436,587		\$1,436,587	

Table 2: Non-Shared Network Upgrade(s)

Non-Shared Network Upgrades Description	ILTCR	Total Cost Estimate (\$)	Allocated Percent (%)	Allocated Cost Estimate (\$)	Estimated Lead Time
<u>Oklaunion 345 kV Substation GEN-2017-033 Interconnection (Non-Shared NU) (AEPW) (132983)</u> : Construct two (2) new 345kV breakers, control panels, line relaying, disconnect switches, structures, foundations, conductors, insulators, and all other associated work and materials.	Ineligible	\$4,000,000	100%	\$4,000,000	24 Months
Total		\$4,000,000		\$4,000,000	

SHARED NETWORK UPGRADE(S)

The Interconnection Customer’s share of costs for Shared Network Upgrades is estimated in **Table 3** below.

Table 3: Interconnection Customer Shared Network Upgrade(s)

Shared Network Upgrades Description	ILTCR	Total Cost Estimate (\$)	Allocated Percent (%)	Allocated Cost Estimate (\$)	Estimated Lead Time
None	N/A	\$0	N/A	\$0	N/A
Total		\$0		\$0	

All studies have been conducted assuming that higher-queued Interconnection Request(s) and the associated Network Upgrade(s) will be placed into service. If higher-queued Interconnection Request(s) withdraw from the queue, suspend or terminate service, the Interconnection Customer’s share of costs may be revised. Restudies, conducted at the customer’s expense, will determine the Interconnection Customer’s revised allocation of Shared Network Upgrades.

CONTINGENT NETWORK UPGRADE(S)

Certain Contingent Network Upgrades are **currently not the cost responsibility** of the Interconnection Customer but will be required for full Interconnection Service.

Table 4: Interconnection Customer Contingent Network Upgrade(s)

Contingent Network Upgrade(s) Description	Current Cost Assignment	Estimated In-Service Date
<u>Border 345kV Reactive Support (NTC 210609):</u> Add 275 MVAR of reactive support at Border 345kV	\$0	4/20/2024

Depending upon the status of higher- or equally-queued customers, the Interconnection Request’s in-service date is at risk of being delayed or Interconnection Service is at risk of being reduced until the in-service date of these Contingent Network Upgrades.

AFFECTED SYSTEM UPGRADE(S)

To facilitate interconnection, the Affected System Transmission Owner will be required to perform the facilities study work as shown below necessary for the acceptance of the Interconnection Customer’s Interconnection Facilities. **Table 5** displays the current impact study costs provided by either MISO or AECI as part of the Affected System Impact review. The Affected System facilities study could provide revised costs and will provide each Interconnection Customer’s allocation responsibilities for the upgrades.

Table 5: Interconnection Customer Affected System Upgrade(s)

Affected System Upgrades Description	Total Cost Estimate (\$)	Allocated Percent (%)	Allocated Cost Estimate (\$)
None	\$0	N/A	\$0
Total	\$0		\$0

CONCLUSION

After all Interconnection Facilities and Network Upgrades have been placed into service, Interconnection Service for 200 MW can be granted. Full Interconnection Service will be delayed until the TOIF, Non-Shared NU, Shared NU, Contingent NU, Affected System Upgrades that are required for full interconnection service are completed. The Interconnection Customer’s estimated cost responsibility for full interconnection service is summarized in the table below.

Table 6: Cost Summary

Description	Allocated Cost Estimate
Transmission Owner Interconnection Facilitie Upgrade(s)	\$1,436,587
Non-Shared Network Upgrade(s)	\$4,000,000
Shared Network Upgrade(s)	\$0
Affected System Upgrade(s)	\$0
Total	\$5,436,587

Use the following link for Quarterly Updates on upgrades from this report: <https://spp.org/spp-documents-filings/?id=18641>

A draft Generator Interconnection Agreement will be provided to the Interconnection Customer consistent with the final results of this IFS report. The Transmission Owner and Interconnection Customer will have 60 days to negotiate the terms of the GIA consistent with the SPP Open Access Transmission Tariff (OATT).

APPENDICES

**A: TRANSMISSION OWNER'S INTERCONNECTION FACILITIES STUDY
REPORT AND NETWORK UPGRADES REPORT(S)**

See next page for the Transmission Owner's Interconnection Facilities Study Report and Network Upgrades Report(s).



AEP Generation Interconnection

Facilities Study Report

for

DISIS 2017-001

GEN-2017-033

Oklaunion 345 kV

Wilbarger County, Texas

September 2021

1 Facilities Study Summary

American Electric Power (AEP) Southwest Transmission Planning performed the following study at the request of the Southwest Power Pool (SPP) for SPP Generation Interconnection request DISIS-2017-001, GEN-2017-033. Per the SPP Generator Interconnection Procedures (GIP), SPP requested that AEP perform an Interconnection Facilities Studies (IFS) for Network Upgrade(s) in accordance with the Scope of Interconnection Facilities Study in GIP 8.10 and the Interconnection Facilities Study Procedures in accordance with GIP 8.13.

1.1 Project Description

Gen-2017-033 proposes to install a 200 MW wind generating facility in Wilbarger County, Texas (Figure 2). The point of interconnection for the generating facility will be AEP's 345 kV Oklaunion substation (Figure 1).

1.2 AEP's Scope of Work to Facilitate Interconnection

- To accommodate the interconnection AEP's existing Oklaunion 345 kV substation will have to have two 345 kV breakers installed in order to terminate the generator Gen-2017-033. The design and construction of the new terminal will meet all AEP specifications. Bus work and disconnect switches will be designed to accommodate the loading requirements, and circuit breakers will be rated to ensure adequate load and fault interrupting capability.
- Installation of associated protection and control equipment, SCADA, and revenue metering will be required at the 345 kV Oklaunion substation. AEP reserves the right to specify the final acceptable configuration considering design practices, future expansion, and compliance requirements.
- AEP will extend one span of 345 kV transmission line from the generators terminal at Oklaunion going to the Gen-2017-033 POI. AEP will build and own the first transmission line structure outside of Oklaunion substation, to which AEP's transmission line conductor will attach. Right of Way (ROW) will be required for this span.
- It is understood that the Interconnection Customer is responsible for all of the connection costs associated with interconnecting Gen-2017-033 to the AEP transmission system. The cost of the customer's generating facility and the costs for the line connecting the generating facility to AEP's transmission system (Beyond the first span exiting the POI station) are not included in this report; these are assumed to be the Customer's responsibility.

- The customer will be responsible for the cost of constructing a fiber-optic connection from their telecom equipment to AEP’s Oklaunion controlhouse.

1.3 ShortCircuitEvaluation

- It is standard practice for AEP to recommend replacing a circuit breaker when the current through the breaker for a fault exceeds 100% of its interrupting rating with recloser de-rating applied, as determined by the ANSI/IEEE C37.5-1979, C37.010-1979 & C37.04-1979 breaker rating methods.
- In the AEP system, no breakers were found to exceed their interrupting capability after the addition of the generation and related facilities. Therefore, there are no additional short circuit upgrade costs associated with the DISIS-2017-001, GEN-2017-033 interconnection.

1.4 Stability Evaluation

- Based on the results of the 2017-001 DISIS Short Circuit and Stability report, the AEP system meets the stability performance requirements for all Planning events that were considered in the study.

1.5 Interconnection Cost of Facilities Included in the Facilities Study:

Network Upgrades (Install two 345 kV breakers and associated PCE work)	\$4,000,000.00
Transmission Owner Interconnection Facilities (TOIF)	\$1,436,587.00
Total Cost	\$5,436,587.00

The estimates do not include the impact that delays in obtaining ROW, permits, or other approvals may have.

1.6 Project Lead time

Project in-service date is projected to be 24 months after the issuance of Authorization to Proceed from the Interconnection Customer.

Figure 1: Point of Interconnection (POI INFORMATION) One-Line Diagram

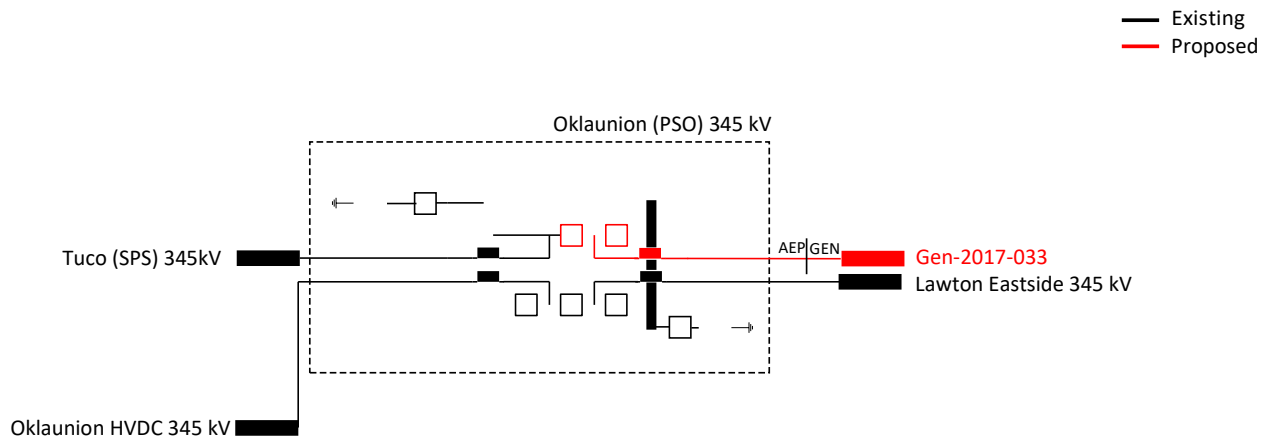

Figure 2: Point of Interconnection Map

