



INTERCONNECTION FACILITIES STUDY REPORT

GEN-2016-121
(IFS-2016-002-26)

Published December 2020

By SPP Generator Interconnections Dept.

REVISION HISTORY

DATE OR VERSION NUMBER	AUTHOR	CHANGE DESCRIPTION
12/19/2019	SPP	Initial draft report issued.
02/21/2020	SPP	Final report issued.
12/18/2020	SPP	Updated final report issued based on DISIS cost allocation changes and OG&E Facility Study update
10/13/2023	SPP	Updated final report issued based on DISIS cost allocation changes and OG&E Facility Study update
04/03/2024	SPP	Updated final report to reflect updated cost for UID 112307

CONTENTS

Revision History.....	i
Summary.....	1
Introduction	1
Phase(s) of Interconnection Service	1
Credits/Compensation for Amounts Advanced for Network Upgrade(s).....	1
Interconnection Customer Interconnection Facilities	2
Transmission Owner Interconnection Facilities and Non-Shared Network Upgrade(s)	3
Shared Network Upgrade(s)	4
Previous Network Upgrade(s).....	6
Affected System Upgrade(s)	7
Conclusion.....	7
Appendices.....	8
A: Transmission Owner’s Interconnection Facilities Study Report and Network Upgrades Report(s)	9

SUMMARY

INTRODUCTION

This Interconnection Facilities Study (IFS) for Interconnection Request GEN-2016-121/IFS-2016-002-28 is for a 110 MW generating facility located in Lea County, New Mexico. The Interconnection Request was initially studied in the DISIS-2016-002 Impact Study for Network Resource Interconnection Service (NRIS) and Energy Resource Interconnection Service (ERIS) and only ERIS in Restudies. The Interconnection Customer's original requested commercial operation date is 12/31/2018. The commercial operation date was revised in the Facility Study Agreement to 12/01/2022.

The interconnecting Transmission Owner, Southwestern Power Service (SPS) performed a detailed IFS at the request of SPP. The full report is included in Appendix A. SPP has determined that full Interconnection Service will be available after the assigned Transmission Owner Interconnection Facilities (TOIF), Non-Shared Network Upgrades, Shared Network Upgrades, Previous Network Upgrades, and Affected System Upgrades that are required for full interconnection service are completed.

The primary objective of the IFS is to identify necessary Transmission Owner Interconnection Facilities, Network Upgrades, other direct assigned upgrades, cost estimates, and associated upgrade lead times needed to grant the requested Interconnection Service.

PHASE(S) OF INTERCONNECTION SERVICE

It is not expected that Interconnection Service will occur in phases. However, full Interconnection Service will not be available until all Interconnection Facilities and Network Upgrade(s) can be placed in service.

CREDITS/COMPENSATION FOR AMOUNTS ADVANCED FOR NETWORK UPGRADE(S)

Interconnection Customer shall be entitled to compensation in accordance with Attachment Z2 of the SPP OATT for the cost of SPP creditable-type Network Upgrades, including any tax gross-up or any other tax-related payments associated with the Network Upgrades, that are not otherwise refunded to the Interconnection Customer. Compensation shall be in the form of either revenue credits or incremental Long Term Congestion Rights (iLTCR).

INTERCONNECTION CUSTOMER INTERCONNECTION FACILITIES

The Generating Facility is proposed to consist of forty four (44) SMA 2.5 MW solar inverters for a total generating nameplate capacity of 110 MW.

The Interconnection Customer's Interconnection Facilities to be designed, procured, constructed, installed, maintained, and owned by the Interconnection Customer at its sole expense include:

- 34.5 kV underground cable collection circuits;
- 34.5 kV to 115 kV transformation substation with associated 34.5 kV and 115 kV switchgear;
- One (1) 115/34.5 kV 69/92/115 MVA step-up transformer to be owned and maintained by the Interconnecting Customer at the Interconnection Customer's substation;
- A 115 kV transmission line to connect the Interconnection Customer's substation to the Point of Interconnection ("POI") at the 115 kV bus at existing Transmission Owner substation ("Roadrunner Substation") that is owned and maintained by Transmission Owner;
- All transmission facilities required to connect the Interconnection Customer's substation to the POI;
- Equipment at the Interconnection Customer's substation necessary to maintain a composite power delivery at continuous rated power output at the high-side of the generator substation at a power factor within the range of 95% lagging and 95% leading in accordance with Federal Energy Regulatory Commission (FERC) Order 827. The Interconnection Customer may use inverter manufacturing options for providing reactive power under no/reduced generation conditions. The Interconnection Customer will be required to provide documentation and design specifications demonstrating how the requirements are met; and,
- All necessary relay, protection, control and communication systems required to protect Interconnection Customer's Interconnection Facilities and Generating Facilities and coordinate with Transmission Owner's relay, protection, control and communication systems.

TRANSMISSION OWNER INTERCONNECTION FACILITIES AND NON-SHARED NETWORK UPGRADE(S)

To facilitate interconnection, the interconnecting Transmission Owner will perform work as shown below necessary for the acceptance of the Interconnection Customer’s Interconnection Facilities.

Table 1 and **Table 2** lists the Interconnection Customer’s estimated cost responsibility for Transmission Owner Interconnection Facilities (TOIF) and Non-Shared Network Upgrade(s) and provides an estimated lead time for completion of construction. The estimated lead time begins when the Generator Interconnection Agreement has been fully executed.

Table 1: Transmission Owner Interconnection Facilities (TOIF)

Transmission Owner Interconnection Facilities (TOIF)	Total Cost Estimate (\$)	Allocated Percent (%)	Allocated Cost Estimate (\$)	Estimated Lead Time
Transmission Owner Roadrunner 115 kV Interconnection Substation: Construct one (1) 115 kV line terminal, line switches, dead end structure, line relaying, communications, revenue metering, line arrester, and all associated equipment and facilities necessary to accept transmission line from Interconnection Customer’s Generating Facility.	\$483,969	100%	\$483,969	14-16 Months
Total	\$483,969		\$483,969	

Table 2: Non-Shared Network Upgrade(s)

Non-Shared Network Upgrades Description	Z2 Type¹	Total Cost Estimate (\$)	Allocated Percent (%)	Allocated Cost Estimate (\$)	Estimated Lead Time
Transmission Owner Roadrunner 115 kV Interconnection Substation: Add an additional 115 kV breaker and associated equipment to the southern-most rung of the 115 kV breaker and half configuration at the Roadrunner substation.	non-creditable	\$637,138	100%	\$637,138	14-16 Months
Total		\$637,138	100%	\$637,138	

¹ Indicates the method used for calculating credit impacts under Attachment Z2 of the Tariff.

SHARED NETWORK UPGRADE(S)

The Interconnection Customer’s share of costs for Shared Network Upgrades is estimated in **Table 3** below.

Table 3: Interconnection Customer Shared Network Upgrade(s)

Shared Network Upgrades Description	Z2 Type	Total Cost Estimate (\$)	Allocated Percent (%)	Allocated Cost Estimate (\$)	Estimated Lead Time
<p>OKGE: Border & Beckham 345 kV Capacitive Reactive Support: Install 1-345kV 39 Mvar Capacitor Bank, 1-345kV Capacitor Breaker, and associated switches, relaying, and control equipment at Border substation.</p> <p>Install 1-345kV 39 Mvar Capacitor Bank, 1-345kV breaker, 1-345kV Capacitor Breaker, and associated switches, relaying, and control equipment at Beckham substation.</p>	creditable	\$12,000,000	17.76%	\$2,131,200	36 Months
<p>AEP: Oklaunion 345 kV Capacitive Reactive Support: Install a minimum of +200Mvar of Capacitor Bank(s) at Oklaunion 345 kV</p>	creditable	\$36,148,953	17.69%	\$6,394,750	24 Months
<p>SPS: Crossroads 345 kV Capacitive Reactive Support: Install +100 Mvar Capacitor Bank(s) at Crossroad 345 kV</p>	creditable	\$7,075,779	8.35%	\$590,828	12/2020
<p>SPS: Deaf Smith-Plant X 230 kV Rebuild: Rebuild line to achieve minimum system emergency rating of 430 MVA</p>	creditable	\$4,578,401	16.35%	\$748,569	12/2020
<p>SPS: Newhart-Plant X 230 kV CKT 1 Rebuild: Rebuild line to achieve minimum system intact/emergency rating of 456 MVA</p>	creditable	\$697,514	15.93%	\$111,113	12/2020
<p>SPS: Curry County-Deaf Smith 115 kV CKT 1 Rebuild: Rebuild line to achieve minimum normal/emergency rating of 90/90 MVA</p>	creditable	\$4,852,215	18.15%	\$880,677	12/2020
<p>SPS: Tolk East-Tuco 230 kV CKT 1 Rebuild: Rebuild line to achieve minimum normal/emergency rating of 478 MVA</p>	creditable	\$968,567	14.06%	\$136,181	12/2020
<p>SPS: Tuco 230 kV Capacitive Reactive Power Support: Install +100 MVar at Tuco 230 kV Substation</p>	creditable	\$5,943,138	17.76%	\$1,055,501	06/2021

SPS: Deaf Smith 115 kV Capacitive Reactive Power Support: Build 100 MVar at Deaf Smith 115 kV Substation	creditable	\$3,318,137	16.35%	\$542,515	11/2021
Total		\$75,582,704		\$12,591,334	

All studies have been conducted assuming that higher-queued Interconnection Request(s) and the associated Network Upgrade(s) will be placed into service. If higher-queued Interconnection

Southwest Power Pool, Inc.

Request(s) withdraw from the queue, suspend or terminate service, the Interconnection Customer's share of costs may be revised. Restudies, conducted at the customer's expense, will determine the Interconnection Customer's revised allocation of Shared Network Upgrades.

PREVIOUS NETWORK UPGRADE(S)

Certain Previous Network Upgrades are **currently not the cost responsibility** of the Interconnection Customer but will be required for full Interconnection Service.

Table 4: Interconnection Customer Previous Network Upgrade(s)

Previous Network Upgrade(s) Description	Current Cost Assignment	Estimated In-Service Date
<u>SPP NTC 200309 Hobbs - Yoakum 345 kV CKT 1:</u> Construct new 52-mile 345 kV line from Hobbs to Yoakum.	\$87,349,796	6/1/2020
<u>SPP NTC 200395 Tuco - Yoakum 345 kV CKT 1:</u> Construct new 107-mile 345 kV line from Tuco to Yoakum. Install any necessary 345 kV terminal equipment at Yoakum associated with new 345/230 kV transformer.	\$123,902,322	6/1/2020
<u>SPP NTC 210484 Yoakum 345/230 kV CKT 1 Transformer:</u> Install new 345/230 kV 640 MVA transformer at Yoakum substation. Install any necessary 230 kV terminal equipment.	\$4,703,455	6/1/2019
<u>SPP NTC 210507 Eddy County - Kiowa 345 kV CKT 1:</u> Build new 34 mile 345 kV line from Eddy County to Kiowa.	\$63,730,259	11/15/2020

Depending upon the status of higher- or equally-queued customers, the Interconnection Request’s in-service date is at risk of being delayed or Interconnection Service is at risk of being reduced until the in-service date of these Previous Network Upgrades.

AFFECTED SYSTEM UPGRADE(S)

To facilitate interconnection, the Affected System Transmission Owner will be required to perform the facilities study work as shown below necessary for the acceptance of the Interconnection Customer’s Interconnection Facilities. **Table 5** displays the current impact study costs as part of the Affected System Impact review. The Affected System facilities study could provide revised costs and will provide each Interconnection Customer’s allocation responsibilities for the upgrades.

Table 5: Interconnection Customer Affected System Upgrade(s)

Affected System Upgrades Description	Total Cost Estimate (\$)	Allocated Share (%)	Allocated Cost Estimate (\$)
None	\$0	N/A	\$0
Total	\$0		\$0

CONCLUSION

After all Interconnection Facilities and Network Upgrades have been placed into service, Interconnection Service for 110 MW can be granted. Interconnection Customer Limited Operation Interconnection Service (LOIS) amount studied in DISIS-2016-002-2 is 0 MW. Full Interconnection Service will be delayed until the TOIF, Non-Shared NU, Shared NU, Previous NU, Affected System Upgrades that are required for full interconnection service are completed. The Interconnection Customer’s estimated cost responsibility for TOIF, Non-Shared NU and Shared NU that is required for full interconnection service is summarized in the table below.

Table 6: Cost Summary

Description	Allocated Cost Estimate
Transmission Owner Interconnection Facilities	\$483,969
Network Upgrades	\$13,228,472
Total	\$13,712,441

A draft Generator Interconnection Agreement will be provided to the Interconnection Customer consistent with the final results of this IFS report. The Transmission Owner and Interconnection Customer will have 60 days to negotiate the terms of the GIA consistent with the SPP Open Access Transmission Tariff (OATT).

APPENDICES

A: TRANSMISSION OWNER'S INTERCONNECTION FACILITIES STUDY REPORT AND NETWORK UPGRADES REPORT(S)

See next page for the Transmission Owner's Interconnection Facilities Study Report and Network Upgrades Report(s).



Facilities Study For Southwest Power Pool (SPP)

GEN-2016-121
Total Output: 110 MW
Lea Co, NM

Xcel Energy Services, Inc.
Transmission Planning South
Updated 12/17/2019

Executive Summary

The Southwest Power Pool (SPP or Transmission Provider) evaluated the request GEN-2016-121 to interconnect the generation facility to the SPS transmission system in the Definitive Interconnection System Impact Study (DISIS-2016-002), which was completed in December 2019.

GEN-2016-121 requested the interconnection of a 110 MW solar energy generation facility, located in Lea County, New Mexico, to the Southwestern Public Service Company (SPS or Transmission Owner) transmission network. To accommodate the Interconnection Customer's (IC) request, SPS will add an additional 115 kV breaker (and associated equipment) to the southern-most rung of the 115 kV breaker and half configuration at the SPS Roadrunner substation. After the addition, the IC will connect to the SPS 115 kV bus. The IC is required to build a 115 kV transmission line from their substation facility to the SPS's Roadrunner substation. The IC will be required to maintain a Power Factor between 0.95 lagging and 0.95 leading at the Point of Interconnection (POI).

SPP requires that each generator shall implement automatic Under Frequency Load Shedding (UFLS) according to the SPP UFLS Plan for SPS found in the Xcel Energy interconnection document for "Large Generation Interconnection Guidelines (>20MW)" found at the following link:

<https://www.transmission.xcelenergy.com/Interconnections>

To fulfill this requirement, coordination with Xcel Energy is required during the under-frequency relay-setting phase for the generation. The IC is required to report their generation off-nominal frequency tripping relay settings to SPP and SPS. SPS specifies that generators shall not trip at frequencies above 58.5 Hz unless exceptions in the Transmission Provider Criteria are met. The IC agrees that the energy generating units installed at this interconnection will not be tripped for under-frequency conditions above 58.5 Hz in compliance with Transmission Provider criteria. This means that the generation subject to this Interconnection Agreement may not trip for under-frequency conditions on the transmission system until all under-frequency load shedding relays have operated. SPS will also require that the IC be in compliance with all applicable criteria, guidelines, standards, requirements, regulations, and procedures issued by the North American Electric Reliability Corporation (NERC), SPP, and the Federal Energy Regulatory Commission (FERC) or their successor organizations.

The IC is responsible for all the cost of the Interconnection Facilities, installation of the direct assigned Transmission Owner Interconnection Facilities (TOIF) which are facilities paid for by the IC but are owned, operated and maintained by SPS; inclusive of all construction required for the IC to interconnect at SPS's Roadrunner substation.

The shared network upgrades will be determined at a later date by SPP and may impact the total overall costs for interconnection of the IC.

It is anticipated that the entire process of adding the additional 115 kV breaker (and associated equipment) for the acceptance of the IC facility output and the network upgrades allocated to this project will require approximately 14-16 months to complete after an Interconnection Agreement is signed and an authorization to proceed is received. The IC's cost for the interconnection of this generation facility is shown below in Table 1, with the detailed description of the cost shown in Table 2.

Table 1 – Cost Summary¹

Shared Network Upgrades Total:	\$ See DISIS Report
Network Upgrades:	\$ 637,138
Transmission Owner Interconnection Facilities:	\$ 483,969
Total:	\$ 1,121,107

¹ The cost estimates are 2019 dollars with an accuracy level of ±20%.

General Description of SPS² Facilities

1. **Construction at the SPS Roadrunner substation:** See Appendix A, Figure A-1 for general vicinity location map of the SPS facility.
 - a. **Location:** IC will build a new 115 kV line from their substation to SPS's 115 kV facilities at the Roadrunner Substation, in Lea Co, NM.
 - b. **Bus Design:** The new 115 kV breaker (and associated equipment) will be added to the sixth row of the breaker and a half configuration at the Roadrunner substation to accommodate the output from the solar energy facility. Appendix A, Figure A-2, shows a preliminary one-line of the new 115 kV breaker at Roadrunner, while Figure A-3 shows a typical elevation view of the normal Point of Interconnection (POI).
 - c. **Revenue Metering:** An individual billing meter will be installed at the SPS substation on the line terminal from the IC's substation, which meets the standards: ANSI C12.1 accuracy class 0.2 (3-PT's IEEE C57.13 accuracy class 0.3 and 3-CT's IEEE C57.13 accuracy class 0.15) for full 3-phase 4-wire metering. Pulses out of the billing meter will be sent via SCADA to the Transmission Owner's Control Center in Amarillo, Texas.
 - i. Wind Interconnections: two meters per line terminal will be installed
 1. One will be primary and the other will be a back up
 - ii. Solar Interconnections: a single meter per line terminal will be installed
 - iii. Coal, Natural Gas, hydro, other: a single meter per line terminal will be installed
 - d. **Disturbance Monitoring Device:** A Disturbance Fault Recorder (DFR), capable of recording faults, swings, and long term trending, will be installed to monitor and record conditions in the substation and on the transmission lines. The disturbance equipment shall also be equipped with a GPS time synching clock. This equipment will have communication capability with a dedicated communication circuit. The disturbance equipment will have its own dedicated communications circuit.
 - e. **Remote Terminal Unit (RTU):** A RTU will be utilized for communications with the new IC facilities. A Communication SEL Relay will be utilized for relay communications and other functions as required; these costs will be directly assigned to the IC. The IC will provide and install a RTU for metering and telemetry at the IC's facility as required by the latest Xcel Energy Interconnection Guidelines.
 - f. **Communications:** To meet its Communications obligations, the IC shall be responsible for making arrangements with the local phone company to provide a communication circuit as required by the Transmission Owner. Transmission Owner equipment may include, but is not limited to the following: relay communication equipment, RTU, and disturbance monitoring equipment. Prior to any construction, the IC is required to contact the Transmission Owner substation-engineering department for all communication details and provide detail of the method to be used in communication.

The following communications schematic diagram, which includes communication equipment information for the IC, Transmission Provider (Southwest Power Pool) and Transmission Owner

² All modifications to SPS facilities will be owned, maintained and operated by SPS

(Southwestern Public Service), is provided to assist the Parties as a template.

A schematic outlining the proposed communications is provided below:

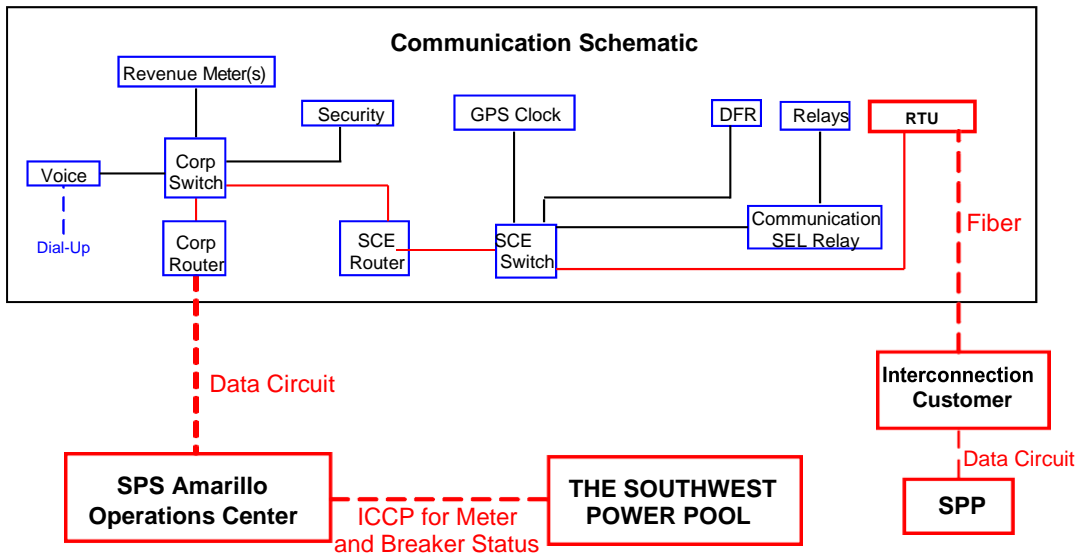

IC shall be responsible for providing the fiber optic communication circuit installed in the overhead transmission line static wire from the customer substation to the SPS substation for protective relaying and for transmitting metering and status data to SPS. Utilizing this fiber optic connection, SPS will establish a direct connection to the IC's RTU.

SPS will not serve as a proxy for communication from the IC to SPP.

2. Transmission Work – Engineering and Construction

- a. **Coordination:** The SPS Transmission Engineering and Design group requires an engineering review of the customer's design prior to any construction by the IC or its contractor on any customer transmission lines or doing work in close proximity to any SPS transmission line. It is the IC's responsibility to initiate the design review in a timely manner before construction of any transmission line begins. If the review has not been made or the design at any of the aforementioned locations is deemed inadequate, the crossing(s) and or termination into the interchange will be delayed until the matters are resolved. SPS will not be held responsible for these delays
- b. **Fault or Short Circuit Study:** The IC will coordinate with the System Protection department at SPS on the available fault current at the interconnection location following the acceptance of the Generator Interconnection Agreement (GIA) and prior to final design on the IC's facilities.
- c. **Schedule:** An engineering and construction schedule for this project is estimated at approximately 14-16 months. Other factors associated with clearances, equipment delays and work schedules could cause additional delays. This is applicable after all required agreements are signed and internal approvals are granted

3. Right-Of-Way

- a. **Permitting:** The IC will be responsible for any permitting and right of way of their substation and their transmission line from their substation to the Point of Interconnection (POI).
- b. **Construction Power and Retail Service:** It is the sole responsibility of the IC to make arrangements for both construction and station power. The IC needs to make arrangements for retail service from the local retail provider. Retail provider and Customer will be responsible for making any necessary transmission service arrangements as required under the SPP OATT.

4. Project and Operating Concerns:

- a. Close work between the Transmission group, the IC’s personnel and local operating groups will be imperative in order to meet any in-service date that has been established.
- b. The IC will be required to maintain a power factor between 0.95 lagging and a 0.95 leading at the Point of Interconnection (POI). All capacitors required will be installed on the lower voltage bus at IC’s substation. This is required to maintain acceptable dynamic voltage rise as per latest revision of the Xcel Energy Interconnection Guidelines for Transmission Interconnection Producer-Owned Generation Greater than 20 MW. If switched reactive devices are used on the IC’s system, they need to be switched in stages where the voltage rise is less than 3%.

5. Estimated Construction Costs

- a. The projects required for the interconnection of GEN-2016-121 consist of the projects summarized in the table below:

Table 2 - Required Interconnection Projects³

Project	Description	Estimated Cost
	Shared Network Upgrades:	
1	The current estimated shared network upgrades to be determined (TBD)	See DISIS Report
	Network Upgrades (at the IC’s expense)	
2	Install new 115 kV breaker (and associated equipment)	\$ 637,138
	Subtotal:	\$637,138
	Transmission Owner Interconnection Facilities (at the IC’s expense)	
3	Communications ⁴	\$ See footnote
4	TOIF	\$ 483,969
	Subtotal:	\$483,969
	Total Cost	\$1,121,107

³ The cost estimates are 2019 dollars with an accuracy level of ±20%.

⁴ It is the Requester’s responsibility to provide both the data circuit and communication circuits, see Section 1.f

Appendix A

Figure A-1. General vicinity location map of the SPS facility



Figure A-2. One-line Diagram at Roadrunner

DIAGRAMS ARE NOT FOR CONSTRUCTION PURPOSES

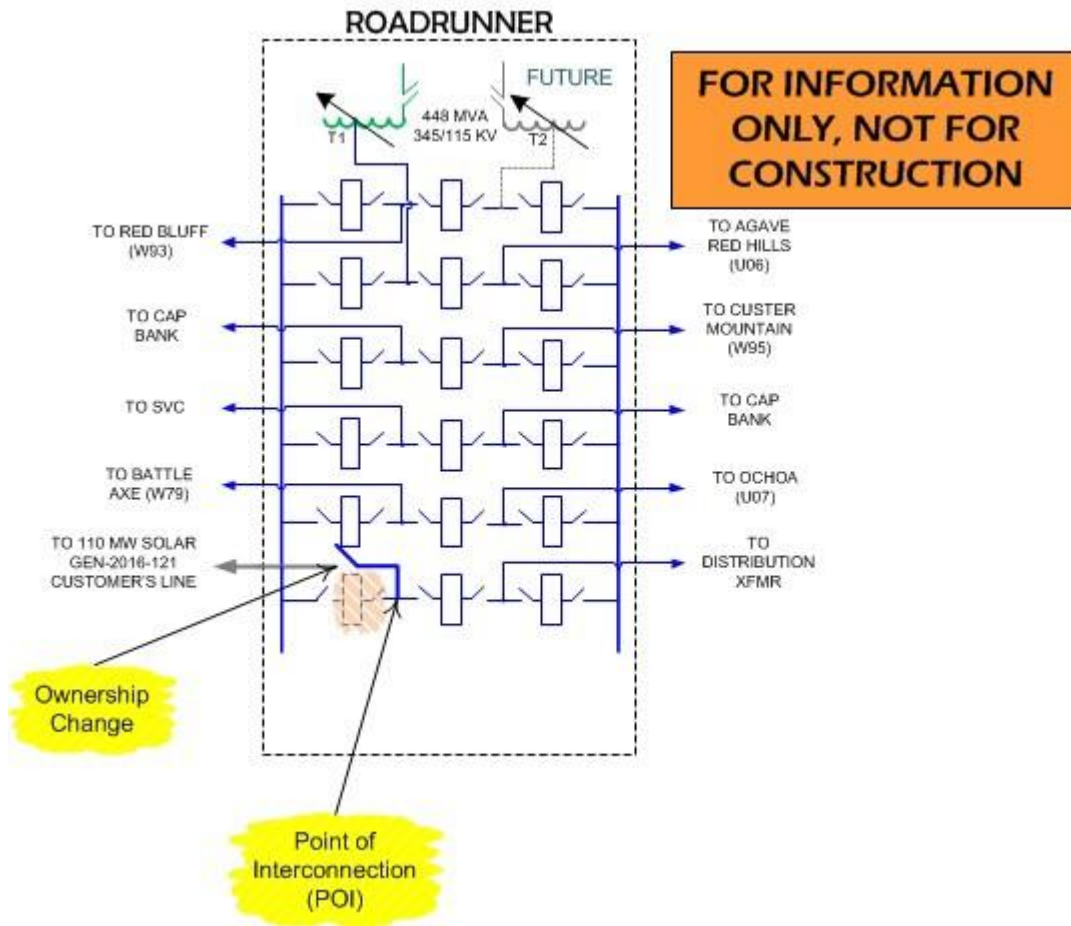
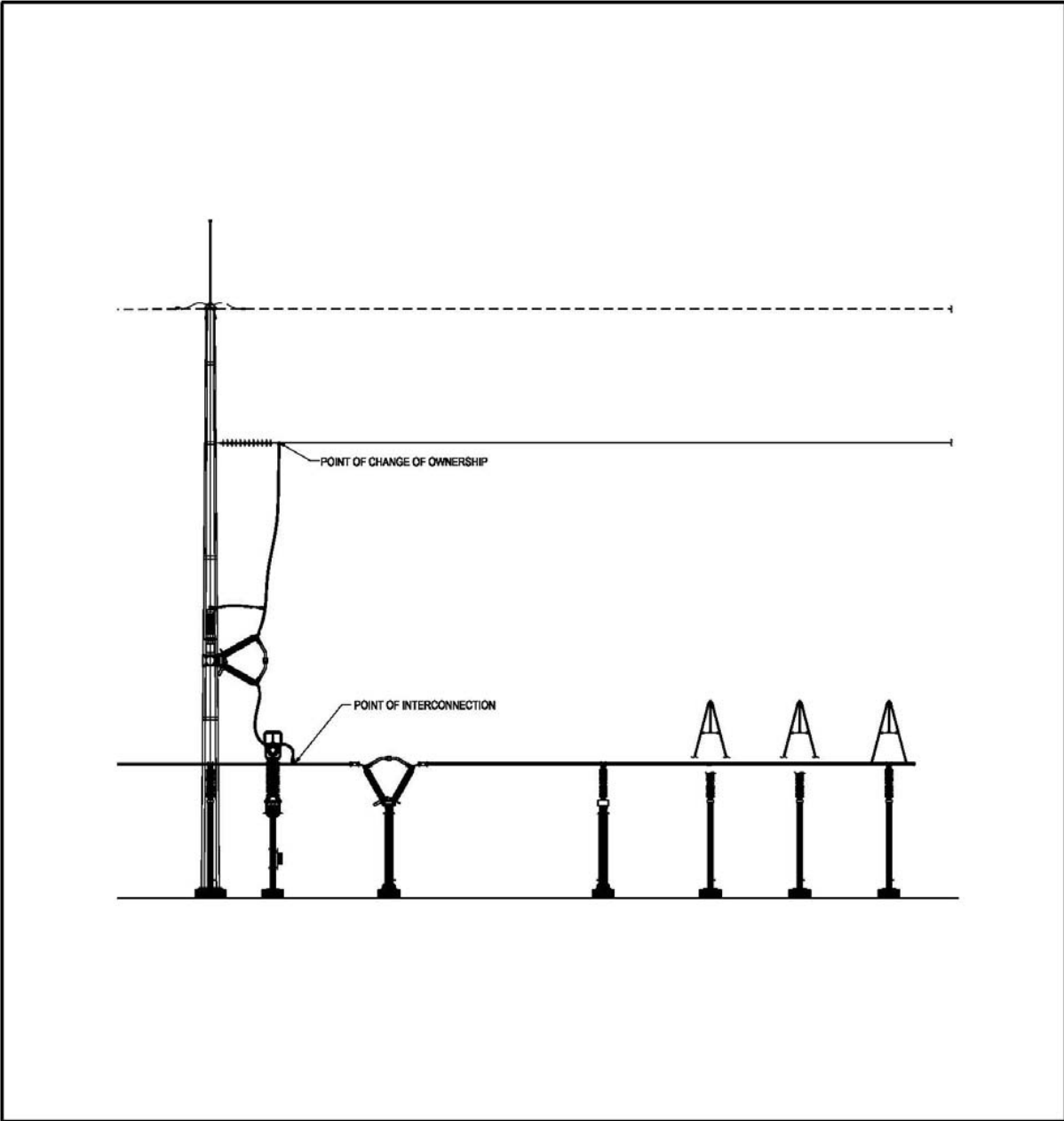

Figure A-3 Point of Interconnection & Change of Ownership Elevation (Typical)

DIAGRAMS ARE NOT FOR CONSTRUCTION PURPOSES



– END OF REPORT –



BOUNDLESS ENERGYSM

***Interconnection Facilities Study for
Oklaunion 345 kV Capacitor
Network Upgrade***

March 2024

Summary

American Electric Power Southwest Transmission Planning (AEP) performed the following study at the request of the Southwest Power Pool (SPP) for SPP Generation Interconnection request DISIS-2016-002. Per the SPP Generator Interconnection Procedures (GIP), SPP requested that AEPW perform an Interconnection Facilities Studies (IFS) for Network Upgrade(s) in accordance with the Scope of Interconnection Facilities Study in GIP 8.10 and the Interconnection Facilities Study Procedures in accordance with GIP 8.13 for the following Network Upgrades:

- Oklaunion 345 kV
 - Install a minimum of + 200 MVAR of capacitor banks

Interconnection Facilities (See Figure 1)

Oklaunion 345 kV Substation

A new 345 kV, 200 MVAR minimum capacitor bank will be added at Oklaunion Station for the generation interconnection. This will consist of three 345 kV capacitor banks and associated breakers, microprocessor relays, circuit disconnects, and other associated equipment.

The design and construction of the new terminals will meet all AEP specifications for stations. Bus work and disconnect switches will be designed to accommodate the loading requirements, and circuit breakers will be rated to ensure adequate load and fault interrupting capability. AEP will own, operate and maintain the station.

Short Circuit Fault Duty Evaluation

It is standard practice for AEP to recommend replacing a circuit breaker when the current through the breaker for a fault exceeds 100% of its interrupting rating with recloser de-rating applied, as determined by the ANSI/IEEE C37.5-1979, C37.010-1979 & C37.04-1979 breaker rating methods.

In the AEP system, no breakers were found to exceed their interrupting capability after the addition of the generation and related facilities. Therefore, there are no short circuit upgrade costs associated with the DISIS-2016-002, UID:112307.

Interconnection Costs

Listed below are the associated costs.

SYSTEM IMPROVEMENT	COST (2019 DOLLARS)
Install a minimum of +200Mvar of Capacitor Bank(s) at Oklaunion 345 kV Including all metering, protection, and SCADA	\$36,148,953
TRANSMISSION INTERCONNECTION FACILITY TOTAL COSTS	\$36,148,953

TABLE 1

Project Lead Time

Project in-service date is projected to be 24 months after the issuance of a NTC from the Southwest Power Pool.

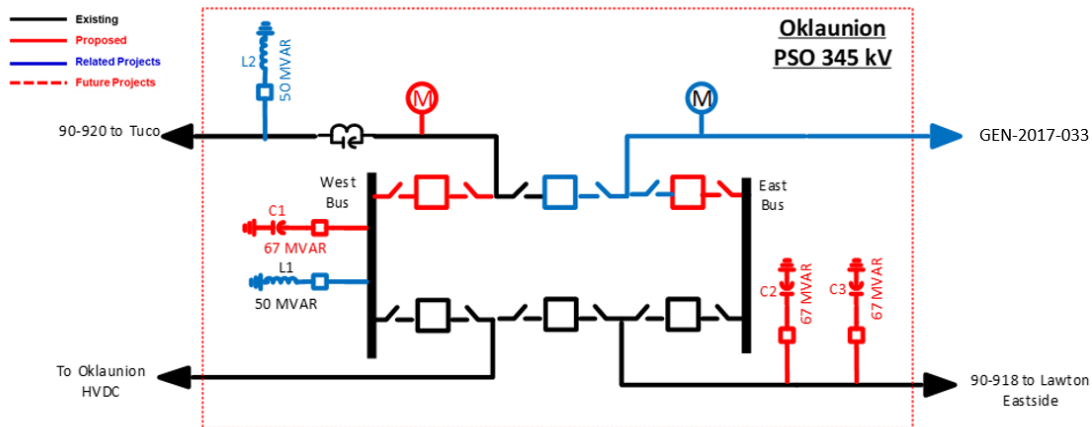

FIGURE 1



**Facility Study for Network Upgrades
as Requested by Southwest Power Pool (SPP)**

DISIS 2016-002-2
Group 6

Xcel Energy Services, Inc.
Transmission Planning South
Updated 12/18/2019

Executive Summary

The Southwest Power Pool (SPP or Transmission Provider) evaluated the generation facilities requesting to interconnect to the SPS transmission system in the Definitive Interconnection System Impact Study (DISIS-2016-002-2), which was completed in December 2019. The requests for interconnection were placed with SPP in accordance with SPP's Open Access Transmission Tariff (OATT).

To accommodate the Interconnection Customer's (IC) requests, SPP identified multiple network upgrades required as part of the DISIS study results. Southwestern Public Service Company (SPS or Transmission Owner) performed this Facility Study for the Network Upgrades to identify costs associated with the identified network upgrades. Below are the projects identified by SPP:

Upgrade Name

Crossroads - Tolk 345 kV Circuit #1 Rating Increase (956 MVA)
Crossroads - Eddy County 345 kV Circuit #1 Rating Increase (956 MVA)
Tolk 345/230 kV Transformer #2
Deaf Smith - Plant X 230 kV Circuit #1 Rating Increase (430 MVA)
Newhart - Plant X 230 kV Circuit #1 Rating Increase (456 MVA)
Curry County- Deaf Smith 115 kV Circuit #1 Rebuild (90 MVA)
Tolk East - Tuco 230 kV Circuit #1 Rating Increase (478 MVA)
Crossroads 345 kV Capacitive Reactive Power Support (100 MVAR)
Tuco 230 kV Capacitive Reactive Power Support (100 MVAR)
Deaf Smith 115 kV Capacitive Reactive Power Support (100 MVAR)
Tolk West - Plant X 230 kV Circuit #1 Rating Increase (796 MVA)*
Tolk East - Plant X 230 kV Circuit #2 Rating Increase (796 MVA)*

*Note: Rating increase identified by SPP DISIS Report is already being completed by SPS

General Description of Network Upgrades

The Objective of this study is to identify the network upgrades and the costs associated with them. Below is a high level description of the different projects and the scoping level costs¹ associated with each. All costs identified below are without escalation. All design and construction of the following projects will meet SPS standards and align with SPS standard equipment sizing. SPS will own, operate, and maintain all equipment identified in this report.

NOTE: All scopes, projects, schedules, and costs below are subject to change as detailed engineering moves forward. Outages, resource availability, federal and state approvals, etc. can impact the costs and schedules.

Crossroads - Tolk 345 kV Circuit 1 Rating Increase (956 MVA)

This existing line rating is currently limited by clearance issues. Approximately 2 structures will have to be replaced to increase the line rating to the required value.

Cost: \$184,650.00

Tentative Schedule: 12/2020

Crossroads - Eddy County 345 kV Circuit 1 Rating Increase (956 MVA)

This existing line rating is currently limited by clearance issues. Approximately 2 structures will have to be replaced to increase the line rating to the required value.

Cost: \$210,533.00

Tentative Schedule: 12/2020

Tolk 345/230 kV Transformer #2

The existing Tolk substation will have a 2nd 345/230 kV 560 MVA transformer installed. The existing 345 kV yard will be expanded to a ring bus configuration. The 345 kV line from Tolk to Crossroads will have to be re-terminated into a new position. Three breakers and 14 switches will be installed on the 345 kV portion and two breakers and four switches will be installed on the 230 kV portion. Relaying upgrades will be required at Crossroads.

Cost: \$14,055,360.00

Tentative Schedule: 3/2022

Deaf Smith - Plant X 230 kV Circuit 1 Rating Increase (430 MVA)

This existing line rating is currently limited by clearance issues. Approximately 100 structures will have to be replaced to increase the line rating to the required value.

Cost: \$4,578,401.00

Tentative Schedule: 12/2020

Newhart - Plant X 230 kV Circuit 1 Rating Increase (456 MVA)

This existing line rating is currently limited by clearance issues. Approximately 12 structures will have to be replaced to increase the line rating to the required value.

Cost: \$697,514.00

Tentative Schedule: 12/2020

Curry County - Deaf Smith 115 kV Circuit 1 Rebuild (90 MVA)

The existing conductor cannot meet the required rating identified by SPP so the line will be rebuilt in the existing corridor. The line is approximately 13 mile long, with 8.3 miles of the line double circuited with a 69 kV line.

Cost: \$4,852,215.00

Tentative Schedule: 12/2021

Tolk East - Tuco 230 kV Circuit 1 Rating Increase (478 MVA)

¹The cost estimates are 2019 dollars with an accuracy level of ±20%.

This existing line rating is currently limited by clearance issues. Approximately 20 structures will have to be replaced to increase the line rating to the required value.

Cost: \$968,567.00

Tentative Schedule: 12/2020

Crossroads 345 kV Capacitive Reactive Power Support (100 MVAR)

The existing Crossroads substation ring bus will be expanded to a breaker and a half configuration and 4 new 345 kV breakers will be installed. There will be two switchable capacitor banks at 50 MVAR each. Each capacitor bank will have its own breaker. The substation footprint will be expanded to the east.

Cost: \$7,075,779.00

Tentative Schedule: 12/2020

Tuco 230 kV Capacitive Reactive Power Support (100 MVAR)

The existing Tuco substation breaker and a half configuration will be expanded to incorporate the proposed new 100 MVAR capacitor banks. Two new 230 kV breakers will be installed. There will be two switchable capacitor banks at 50 MVAR each. Each capacitor bank will have its own breaker. A pending EMTP study is still required to be run and the results may change the proposed scope.

Cost: \$5,943,138

Tentative Schedule: 6/2021

Deaf Smith 115 kV Capacitive Reactive Power Support (100 MVAR)

SPS has a planned project to rebuild the existing Deaf Smith 115 kV bus at a new location called Tierra Blanca substation. The capacitor banks identified by SPP will be installed at this new location. The Tierra Blanca substation will be built in a breaker and a half configuration. Current proposal is to install 3 x 40 MVAR capacitor banks. Four new 115 kV breakers and four new switches will be installed. A pending EMTP study is still required to be run and the results may change the proposed scope.

Cost: \$3,318,137.00

Tentative Schedule: 11/2021

Tolk West - Plant X 230 kV Circuit 1 Rating Increase (796 MVA)

This rating will be already met with an existing SPS project

Cost: \$0

Tentative Schedule: N/A

Tolk East - Plant X 230 kV Circuit 2 Rating Increase (796 MVA)

This rating will be already met with an existing SPS project

Cost: \$0

Tentative Schedule: N/A

– END OF REPORT –



FACILITY STUDY

for

IFS-2016-002-1 Network Upgrades For DISIS-2016-002-1

New 39 Mvar Capacitor Bank at Border Substation
and new 39 Mvar Capacitor Bank at Beckham Substation
In Beckham County, Oklahoma

September 5, 2023

Matt Ritz, P.E.
Senior Engineer
Transmission Planning
OG&E Electric Services

Summary

Pursuant to the tariff and at the request of the Southwest Power Pool (SPP), Oklahoma Gas and Electric (OG&E) performed the following Facility Study for Network Upgrades to satisfy the Facility Study Agreement executed by the requesting customer for SPP IFS-2016-002-1 for Network Upgrades. The request for interconnection was placed with SPP in accordance SPP's Open Access Transmission Tariff, which covers new generation interconnections on SPP's transmission system. The requirements for the Network Upgrade are to install two 39 MVar 345kV capacitor bank, and associated control and protection equipment. One at Border substation and one at Beckham substation in Beckham County, OK. The total estimated cost to complete these upgrades is \$12M.

Table of Contents

Table of Contents	3
Introduction	4
Interconnection Facilities	5
Interconnection Costs	6
One-Line diagram of Interconnection	7

Introduction

The Southwest Power Pool has requested a Facility Study for Network Upgrades within the service territory of OG&E Electric Services (OKGE) in Beckham County Oklahoma. The proposed Network Upgrade Facilities are for the addition of a 345kV 39 Mvar capacitor bank at Border substation, and an identical 39 Mvar capacitor bank at Beckham substation in Beckham county Oklahoma.

Other Network Constraints in the American Electric Power West (AEPW), Southwest Public Service (SPS), OKGE and Western Farmers Electric Cooperative (WFEC) systems may be verified with a transmission service request and associated studies.

Network Upgrade Facilities

The primary objective of this study is to identify network upgrades. The requirements for this Network Upgrade consist of installing a 39 Mvar capacitor bank at Border substation, and an identical 39 Mvar capacitor bank at Beckham substation, on the 345kV OG&E transmission system to accommodate generator interconnection requests identified in SPP-GI DISIS-2016-002-1. These 345kV network upgrades shall be constructed and maintained by OKGE.

The total cost for OKGE to install 345kV switches, two 345kV 39 Mvar capacitor banks, two 345kV capacitor breakers, and associated protection and control equipment in Border and Beckham substations is estimated at \$12,000,000 as of August 2023.

This Facility Study does not guarantee the availability of transmission service necessary to deliver the additional generation to any specific point inside or outside the Southwest Power Pool (SPP) transmission system. The transmission network facilities may not be adequate to deliver the additional generation output to the transmission system. If the customer requests firm transmission service under the SPP Open Access Transmission Tariff at a future date, Network Upgrades or other new construction may be required to provide the service requested under the SPP OATT.

The estimated costs of interconnecting the facility to the OKGE transmission system are listed in Table 1.

Short Circuit Fault Duty Evaluation

It is standard practice for OG&E to recommend replacing a circuit breaker when the current through the breaker for a fault exceeds 100% of its interrupting rating with re-closer de-rating applied, as determined by the ANSI/IEEE C37.5-1979, C37.010-1979 & C37.04-1979 breaker rating methods.

For this Network Upgrade, no breakers were found to exceed their interrupting capability after the addition of the capacitors and related facilities. OG&E found no breakers that exceeded their interrupting capabilities on their system. Therefore, there is no short circuit upgrade costs associated with this DISIS-2016-002-1 Network Upgrade.

Table 1: Required Interconnection Network Upgrade Facilities

Facility	ESTIMATED COST (2023 DOLLARS) Estimated 36 month lead time
OKGE – Network Upgrades	\$12,000,000.
Install 1-345kV 39 Mvar Capacitor Bank, 1-345kV Capacitor Breaker, and associated switches, relaying, and control equipment at Border substation.	
Install 1-345kV 39 Mvar Capacitor Bank, 1-345kV breaker, 1-345kV Capacitor Breaker, and associated switches, relaying, and control equipment at Beckham substation.	
Total	\$12,000,000.

Prepared by:
 Matt Ritz, P.E.
 Senior Engineer, Transmission Planning
 Email ritzjm@oge.com

Reviewed by:
 Adam Snapp, P.E.
 Manager, Transmission Planning
 Email snappad@oge.com

Border Substation: Oonline Diagram (preliminary)

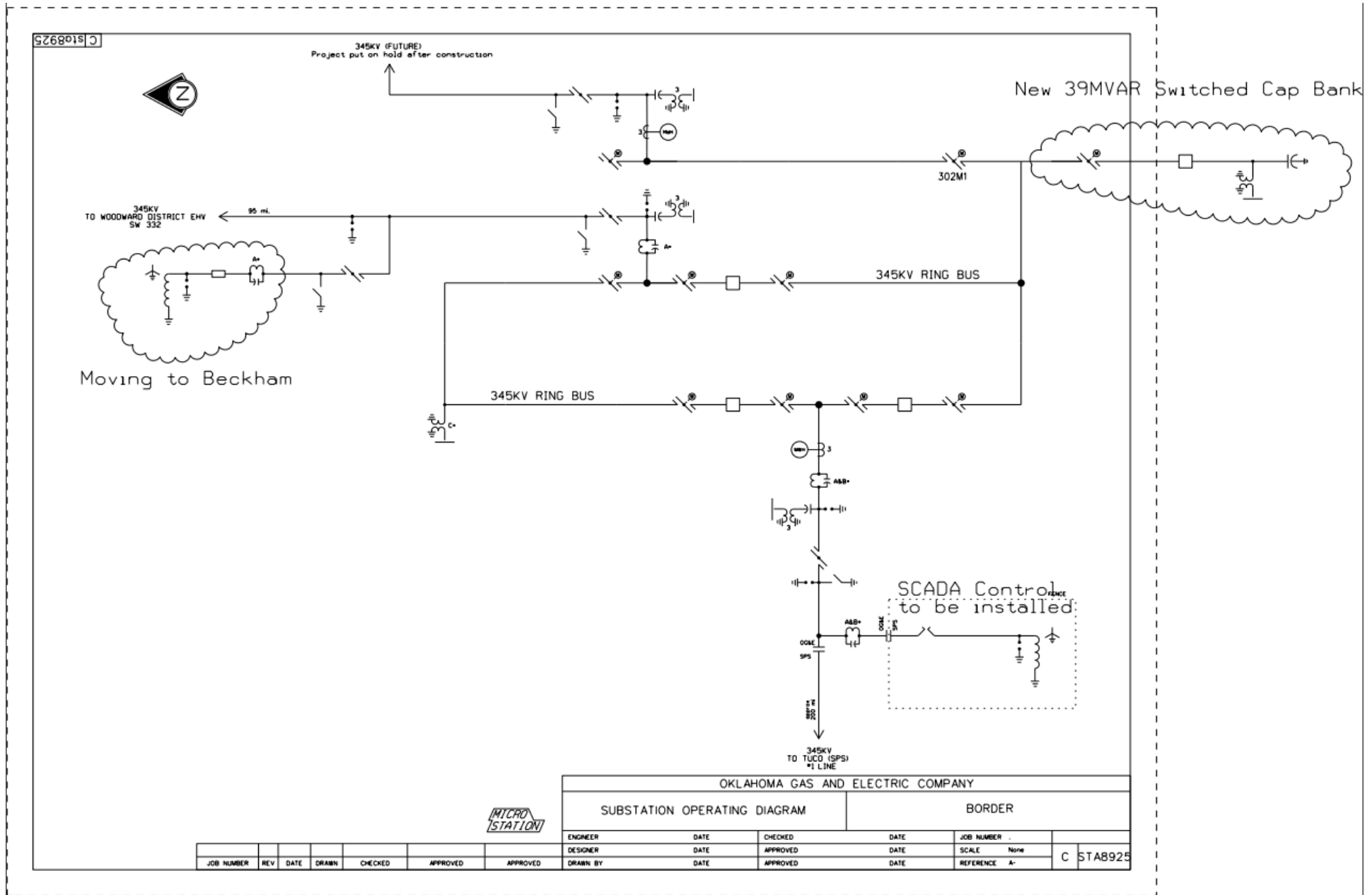

OKLAHOMA GAS AND ELECTRIC COMPANY					
SUBSTATION OPERATING DIAGRAM			BORDER		
ENGINEER	DATE	CHECKED	DATE	JOB NUMBER	
DESIGNER	DATE	APPROVED	DATE	SCALE None	C STAB925
DRAWN BY	DATE	APPROVED	DATE	REFERENCE A-	

JOB NUMBER	REV	DATE	DRAWN	CHECKED	APPROVED	APPROVED
------------	-----	------	-------	---------	----------	----------

Beckham County Substation: Oneline Diagram (preliminary)

