



**INTERCONNECTION
FACILITIES STUDY
REPORT**

NPPD
(IFS-2015-002)

Published March 2017

By SPP Generator Interconnections Dept.

REVISION HISTORY

DATE OR VERSION NUMBER	AUTHOR	CHANGE DESCRIPTION	COMMENTS
1/24/2017	SPP	Initial draft report issued.	
3/16/2017	SPP	Initial final report issued.	Table 9 Updates to include NPPD required "Other Upgrades"

CONTENTS

Revision History.....	i
Summary.....	1
Introduction	1
Phase(s) of Interconnection Service	1
Credits/Compensation for Amounts Advanced for Network Upgrade(s).....	2
Interconnection Customer Interconnection Facilities	2
Transmission Owner Interconnection Facilities and Non-Shared Network Upgrade(s).....	4
Shared Network Upgrade(s)	8
Other Network Upgrade(s)	1
Affected System Upgrade(s)	1
Conclusion.....	1
Appendices.....	2
A: Transmission Owner’s Interconnection Facilities Study Report.....	3
B: Affected System Facilities Study Report.....	4
C: Customer Comments For Facilities Study Report.....	5

SUMMARY

INTRODUCTION

This Interconnection Facilities Study (IFS) is for Interconnection Requests listed in **Table 1**.

Table 1: IFS-2015-002 NPPD Interconnection Facilities Request(s)

Request Number	Location	Fuel Source	Service Type	Amount (MW)	Original Customer Proposed In-Service Date
GEN-2015-053 ¹ IFS-2015-002-12	Antelope County, Nebraska	Wind	ERIS	50.12	12/31/2017
GEN-2015-076 ¹ IFS-2015-002-35	Cedar County, Nebraska	Wind	ERIS	158.40	7/31/2017
GEN-2015-087 IFS-2015-002-31	Thayer County, Nebraska	Wind	ERIS/NRIS	66.00	1/1/2019
GEN-2015-088 IFS-2015-002-32	Saline County, Nebraska	Wind	ERIS/NRIS	300.00	1/1/2019

The interconnecting Transmission Owner, Nebraska Public Power District (NPPD), performed a detailed IFS at the request of SPP. The full report is included in Appendix A. Additionally, the Affected System, Midcontinent Independent System Operator (MISO), has identified the need to perform a detailed Affected System Facilities Study for impacts on the MISO transmission system. SPP has determined that full Interconnection Service will be available after the assigned Transmission Owner Interconnection Facilities, Non-Shared Network Upgrades, Shared Network Upgrades, and Affected System Upgrades are completed.

The primary objective of the IFS is to identify necessary Transmission Owner Interconnection Facilities, Network Upgrade(s), other direct assigned upgrade(s), and associated upgrade lead times needed to grant the requested Interconnection Service at the specified Point of Interconnection (POI).

PHASE(S) OF INTERCONNECTION SERVICE

It is not expected that Interconnection Service will occur in phases. However, Interconnection Service will not be available until all Interconnection Facilities and Network Upgrade(s) can be placed in service.

¹ The Interconnection Request was studied in the DISIS-2015-002 Impact Study for Energy Resource Interconnection Service (ERIS) and Network Resource Interconnection Service (NRIS). Prior to an executed IFS agreement, the Interconnection Customer requested to withdraw NRIS per Section 4.4.1 of the Southwest Power Pool (SPP) Generator Interconnection Procedures (GIP), therefore ERIS-only was analyzed for this request in the DISIS-2015-002-1 Impact Restudy and DISIS-2015-002-2 Impact Restudy.

CREDITS/COMPENSATION FOR AMOUNTS ADVANCED FOR NETWORK UPGRADE(S)

Interconnection Customer shall be entitled to compensation in accordance with Attachment Z2 of the SPP OATT for the cost of SPP Network Upgrades, including any tax gross-up or any other tax-related payments associated with the Network Upgrades, that are not otherwise refunded to the Interconnection Customer. Compensation shall be in the form of either revenue credits or incremental Long Term Congestion Rights (iLTCR).

INTERCONNECTION CUSTOMER INTERCONNECTION FACILITIES

The Generating Facilities for each Interconnection Customer are described in **Table 2** and **Table 3**.

Table 2: IFS-2015-002 Generator Lead and POI

Request Number	Generator Lead Voltage/Length	POI
GEN-2015-053 IFS-2015-002-12	Less than (<1) mile 115kV overhead	Antelope 115kV
GEN-2015-076 IFS-2015-002-35	Fourteen (14) mile 115kV overhead	Belden 115kV
GEN-2015-087 IFS-2015-002-31	Two-and-a-half (2.5) mile 115kV overhead	Tap Fairbury - Hebron 115kV
GEN-2015-088 IFS-2015-002-32	Two-and-a-half (2.5) mile 345kV overhead	Tap Moore - Pauline 345kV

Table 3: IFS-2015-002 Generating Facilities

Request Number	Generators	Step Up Transformer	Minimum Mvar Required
GEN-2015-053 IFS-2015-002-12	Twenty-Eight (28) G.E. 1.79MW = 50.12MW	One (1) 115/34.5kV 100/133/166 MVA (ONAN/ONAF/ONAF)	7.70
GEN-2015-076 IFS-2015-002-35	Forty-eight (48) Vestas 3.3MW = 158.4MW	Two (2) 115/34.5kV 66/88/110 MVA (ONAN/ONAF/ONAF)	5.2
GEN-2015-087 IFS-2015-002-31	Thirty-three (33) Vestas 2.0MW = 66.00MW	One (1) 115/34.5kV 51/68/85 MVA (ONAN/ONAF/ONAF)	6.1
GEN-2015-088 IFS-2015-002-32	One-hundred-fifty (150) Vestas 2.0MW = 300.00MW	Two (2) 345/34.5kV 100/133/167 MVA (ONAN/ONAF/ONAF)	26.85

Each Interconnection Customer’s Interconnection Facilities to be designed, procured, constructed, installed, maintained, and owned by the Interconnection Customer at its sole expense include:

- A 34.5kV collector system;
- Step-up transformer as listed in **Table 3** to be owned and maintained by the Interconnection Customer at the Interconnection Customer’s substation;
- Overhead transmission line as listed in **Table 2** to connect the Interconnection Customer’s substation to the POI;

Southwest Power Pool, Inc.

- All transmission facilities required to connect the Interconnection Customer's substation to the POI;
- Equipment at the Interconnection Customer's substation necessary to maintain a power factor at the POI between 95% lagging and 95% leading, including the amount listed in **Table 3**² of reactors to compensate for injection of reactive power into the transmission system under no/reduced generating conditions. The Interconnection Customer may use wind turbine manufacturing options for providing reactive power under no/reduced generation conditions. The Interconnection Customer will be required to provide documentation and design specifications demonstrating how the requirements are met.

The Interconnection Customer shall coordinate relay, protection, control, and communication system configurations and schemes with the Transmission Owner.

² This approximate minimum reactor amount is needed for the current configuration of the wind farm as studied in the DISIS-2015-002 Impact Study.

TRANSMISSION OWNER INTERCONNECTION FACILITIES AND NON-SHARED NETWORK UPGRADE(S)

To facilitate interconnection, the interconnecting Transmission Owner will perform work as shown below necessary for the acceptance of the Interconnection Customer’s Interconnection Facilities.

Table 4 through **Table 7** lists the Interconnection Customer’s estimated cost responsibility for Transmission Owner Interconnection Facilities (TOIF) and Non-Shared Network Upgrade(s) and provides an estimated lead time for completion of construction. The estimated lead time begins when the Generator Interconnection Agreement has been fully executed.

Table 4: Interconnection Customer, GEN-2015-053 TOIF and Non-Shared Network Upgrade(s)

TOIF and Non-Shared Network Upgrades Description	Allocated Cost Estimate (\$)	Allocated Percent (%)	Total Cost Estimate (\$)	Estimated Lead Time
<u>NPPD Antelope Substation: Transmission Owner Interconnection Facilities</u> Construct one (1) 115 kV line terminal, line switches, dead end structure, line relaying, communications, revenue metering, line arrester and all associated equipment and facilities necessary to accept transmission line from Interconnection Customer’s Generating Facility.	\$300,000	100%	\$300,000	24-36 Months
<u>NPPD Antelope Substation - Non-Shared Network Upgrades</u> Construct two (2) 2000 continuous ampacity breakers, line relaying, disconnect switches, structures, foundations, conductors, insulators, and all other associated work and materials.	\$2,600,000	100%	\$2,600,000	
<u>Albion - Petersburg - North Petersburg 115kV Circuit #1</u> Re-conductor approximately twelve (12) miles of 115kV and upgrade associated terminal equipment.	\$2,500,000	100%	\$2,500,000	
Total	\$5,400,000	100%	\$5,400,000	

Table 5: Interconnection Customer, GEN-2015-076 TOIF and Non-Shared Network Upgrade(s)

TOIF and Non-Shared Network Upgrades Description	Allocated Cost Estimate (\$)	Allocated Percent (%)	Total Cost Estimate (\$)	Estimated Lead Time
<u>NPPD Belden Substation: Transmission Owner Interconnection Facilities</u> Construct one (1) 115 kV line terminal, line switches, dead end structure, line relaying, communications, revenue metering, line arrester and all associated equipment and facilities necessary to accept transmission line from Interconnection Customer’s Generating Facility.	\$300,000	100%	\$300,000	24-36 Months
<u>NPPD Belden Substation - Non-Shared Network Upgrades</u> Construct two (2) 2000 continuous ampacity breakers, line relaying, disconnect switches, structures, foundations, conductors, insulators, and all other associated work and materials.	\$2,900,000	100%	\$2,900,000	
<u>WAPA/Northwestern Gavins Point - Yankton Junction 115kV</u> Rebuild approximately five (5) miles of 115kV and replace associated terminal equipment	\$5,000,000 (Preliminary)	100%	\$5,000,000 ³ (Preliminary)	TBD
Total	\$8,200,000	100%	\$8,200,000	

³ Western Area Power Administration and Northwestern Energy are currently performing their facilities studies for this particular upgrade. Once the studies are received, SPP will update the report with the facility study grade cost estimate.

Table 6: Interconnection Customer, GEN-2015-087 TOIF and Non-Shared Network Upgrade(s)

TOIF and Non-Shared Network Upgrades Description	Allocated Cost Estimate (\$)	Allocated Percent (%)	Total Cost Estimate (\$)	Estimated Lead Time
<u>NPPD Belvidere Substation: Transmission Owner Interconnection Facilities</u> Construct one (1) 115 kV line terminal, line switches, dead end structure, line relaying, communications, revenue metering, line arrester and all associated equipment and facilities necessary to accept transmission line from Interconnection Customer’s Generating Facility.	\$300,000	100%	\$300,000	48 Months
<u>NPPD Belvidere Substation - Non-Shared Network Upgrades</u> Construct new substation and three (3) line terminals, three (3) 2000 continuous ampacity breakers, cut in transmission line and re-terminate, line relaying, disconnect switches, structures, foundations, conductors, insulators, and all other associated work and materials.	\$5,300,000	100%	\$5,300,000	
<u>NPPD Belvidere – Fairbury 115kV circuit #1</u> uprate Belvidere – Fairbury to at least 107 MVA	\$1,700,000	100%	\$1,700,000	36-48 Months
<u>NPPD Beatrice – Harbine 115kV circuit #1</u> uprate Beatrice – Harbine to at least 102 MVA	\$900,000	100%	\$900,000	36-48 Months
Total	\$8,200,000	100%	\$8,200,000	

Table 7: Interconnection Customer, GEN-2015-088 TOIF and Non-Shared Network Upgrade(s)

TOIF and Non-Shared Network Upgrades Description	Allocated Cost Estimate (\$)	Allocated Percent (%)	Total Cost Estimate (\$)	Estimated Lead Time
<u>NPPD Tobias Substation: Transmission Owner Interconnection Facilities</u> Construct one (1) 345 kV line terminal, line switches, dead end structure, line relaying, communications, revenue metering, line arrester and all associated equipment and facilities necessary to accept transmission line from Interconnection Customer’s Generating Facility.	\$700,000	100%	\$700,000	48 Months
<u>NPPD Tobias Substation - Non-Shared Network Upgrades</u> Construct new substation with three (3) terminal, five (5) 3000 continuous ampacity breakers, cut in transmission line and re-terminate, control panel replacement, line relaying, disconnect switches, structures, foundations, conductors, insulators, and all other associated work and materials.	\$11,700,000	100%	\$11,700,000	
Total	\$12,400,000	100%	\$12,400,000	

SHARED NETWORK UPGRADE(S)

The Interconnection Customer’s share of costs for Shared Network Upgrades is estimated in **Table 8** below.

Table 8: GEN-2015-053 Shared Network Upgrades

Shared Network Upgrades Description	GEN-2015-053 Allocated Cost (\$)/Percent (%)	GEN-2015-076 Allocated Cost (\$)/Percent (%)	GEN-2015-087 Allocated Cost (\$)/Percent (%)	GEN-2015-088 Allocated Cost (\$)/Percent (%)	Total Cost Estimate (\$)
<u>Currently None</u>	\$0/NA	\$0/NA	\$0/NA	\$0/NA	\$0
Total	\$0/NA	\$0/NA	\$0/NA	\$0/NA	\$0

All studies have been conducted assuming that higher-queued Interconnection Request(s) and the associated Network Upgrade(s) will be placed into service. If higher-queued Interconnection Request(s) withdraw from the queue, suspend or terminate service, the Interconnection Customer’s share of costs may be revised. Restudies, conducted at the customer’s expense, will determine the Interconnection Customer’s revised allocation of Shared Network Upgrades.

OTHER NETWORK UPGRADE(S)

Certain Other Network Upgrades listed in **Table 9** for each Interconnection Request are currently not the cost responsibility of the Interconnection Customer but will be required for full Interconnection Service based on the SPP DISIS and NPP facility study results.

Table 9: Other Network Upgrades

Other Network Upgrades Description	GEN-2015-053	GEN-2015-076	GEN-2015-087	GEN-2015-088	Current Cost Estimate (\$)	Estimate In-Service Date
Battle Creek – County Line – Neligh East (Antelope) 115kV Circuit #1 assigned to DISIS-2013-002 Interconnection Customer(s)	X				\$4,000,000	5/1/2017
Gentleman – Thedford – Holt 345kV (R-plan) Project assigned in the SPP 2012 Integrated Transmission Plan – 10 Yea Assessment (2012 ITP10) per SPP-200220	X	X	X	X	\$323,613,423	10/1/2019
Twin Church – Dixon County 230kV Circuit #1 increase conductor clearances assigned to DISIS-2010-002 and DISIS-2011-001 Interconnection Customer(s)	X		X	X	\$500,000	11/1/2018

GEN-2015-087 and GEN-2015-088 are currently be evaluated in a Limited Operation Impact Study (LOIS) for determination of limited operation Interconnection Service amounts prior to the in-service of the “R-plan”. The LOIS results will be incorporated into the executed GIA. The LOIS results will be posted in a separate report.

Depending upon the status of higher- or equally-queued customers, the Interconnection Request’s in-service date is at risk of being delayed or Interconnection Service is at risk of being reduced until the in-service date of these Other Network Upgrades.

AFFECTED SYSTEM UPGRADE(S)

To facilitate interconnection, the Affected System Transmission Owner will be required to perform the facilities study work as shown below necessary for the acceptance of the Interconnection Customer’s Interconnection Facilities. The Affected System Transmission Owner is currently waiting on executed facilities agreements from SPP Interconnection Customers mentioned in this report. The Affected System Upgrades will be required for full SPP Interconnection Service. **Table 10** displays the current impact study costs provided by MISO as part of the Affected System Impact review. The Affected System facilities study could provide revised costs and will provide each Interconnection Customer’s allocation responsibilities for the upgrades.

Table 10: Interconnection Customer Affected System Upgrades

Affected System Upgrades Description	GEN-2015-053 Allocated Cost (\$)/Percent (%)	GEN-2015-076 Allocated Cost (\$)/Percent (%)	GEN-2015-087 Allocated Cost (\$)/Percent (%)	GEN-2015-088 Allocated Cost (\$)/Percent (%)	Total Cost Estimate (\$)
<u>Bondurant – Montezuma 345kV circuit #1</u> Replace structures, wave trap, update CT and relay settings.	TBD	TBD	TBD	TBD	TBD
Total	TBD	TBD	TBD	TBD	TBD

CONCLUSION

After all Interconnection Facilities, Network Upgrades, and Affected System Upgrades have been placed into service, Interconnection Service for requests listed in **Table 1** can be granted. Interconnection Service will be delayed until the Transmission Owner Interconnection Facilities, Non-Shared Network Upgrades, Shared Network Upgrades, Other Network Upgrades, and Affected System Upgrades are completed. The Interconnection Customer’s estimated cost responsibility for Transmission Owner Interconnection Facilities, Non-Shared Network Upgrades is summarized in the table below.

Table 11: Cost Summary

Request Number	Transmission Owner Interconnection Facilities	Network Upgrades	Affected System Upgrades	Total
GEN-2015-053 IFS-2015-002-12	\$300,000	\$5,100,000	TBD	\$5,400,000
GEN-2015-076 IFS-2015-002-35	\$300,000	\$7,900,000	TBD	\$8,200,000
GEN-2015-087 IFS-2015-002-31	\$300,000	\$7,900,000	TBD	\$8,200,000
GEN-2015-088 IFS-2015-002-32	\$700,000	11,700,000	TBD	\$12,400,000

A draft Generator Interconnection Agreement will be provided to the Interconnection Customer consistent with the final results of this IFS report. The Transmission Owner and Interconnection Customer will have 60 days to negotiate the terms of the GIA consistent with the SPP Open Access Transmission Tariff (OATT).

APPENDICES

A: TRANSMISSION OWNER'S INTERCONNECTION FACILITIES STUDY REPORT

See next page for the Transmission Owner's Interconnection Facilities Study Report.

**DISIS-2015-002-1
GENERATION INTERCONNECTION
FACILITY STUDY**

**SPP GEN-2015-053 50.0 MW at Antelope 115 kV Substation
SPP GEN-2015-076 158.4 MW at Belden 115 kV Substation
SPP GEN-2015-087 66.0 MW at Belvidere 115 kV Substation
SPP GEN-2015-088 300.0 MW at Tobias 345 kV Substation**

DECEMBER 2016

**PREPARED FOR:
SOUTHWEST POWER POOL**

**PREPARED BY:
NEBRASKA PUBLIC POWER DISTRICT OPERATIONS
TRANSMISSION ASSET PLANNING
T&D ASSET MANAGEMENT
T&D ENGINEERING**



Nebraska Public Power District

"Always there when you need us"

Table of Contents

EXECUTIVE SUMMARY	
1.0	INTRODUCTION 1
2.0	STUDY SCOPE..... 2
2.1	Overview..... 2
2.2	Loadflow Analysis 4
2.3	Short Circuit Analysis..... 5
2.4	Stability Analysis..... 5
2.5	Detailed Cost Estimates and Project Schedule 6
3.0	MODEL DEVELOPMENT 7
4.0	STUDY CRITERIA..... 9
5.0	LOADFLOW ANALYSIS 10
5.1	Phase 1 Results (P0-P1 events)..... 10
5.2	Phase 2 Results (P2-P7 Events) 13
5.3	Phase 3 Results (N-2 Contingency Analysis) 15
6.0	SHORT CIRCUIT ANALYSIS..... 17
6.1	Model Development..... 17
6.2	Study Methodology..... 19
6.3	Results..... 19
7.0	STABILITY ANALYSIS 21
7.1	Model 21
7.2	Results (P1-P7, Extreme Events)..... 22
7.3	Stability Analysis Summary 22
8.0	DETAILED COST ESTIMATES AND PROJECT SCHEDULE 25

Executive Summary

The *NPPD DISIS-2015-002-1 Facility Study* was performed to document the reliability impacts of generation projects that are proposed to interconnect to the NPPD transmission system. These projects have developed through the SPP Definitive Interconnection System Impact Study process and have advanced to the facility study stage. SPP has requested that NPPD perform the Facility Study associated with the generation interconnection projects listed below:

<u>Project</u>	<u>MW</u>	<u>Type</u>	<u>Point-of-Interconnection</u>
GEN-2015-053	+50.0	Wind	Antelope 115 kV Substation
GEN-2015-076	+158.4	Wind	Belden 115 kV Substation
GEN-2015-087	+66.0	Wind	Belvidere 115 kV Substation
GEN-2015-088	<u>+300.0</u>	Wind	Tobias 345 kV Substation
	+574.4		

SPP entered into a facility study agreement with each of the generation interconnection customers and subsequently requested that NPPD perform the Facility Study for each request. This facility study focused on the impacts of the generation interconnection projects which included a detailed loadflow analysis, short circuit analysis and stability analysis. The Facility Study also includes detailed cost estimates and estimated project schedules for the interconnection and network upgrades identified in the System Impact and Facility Study.

The DISIS-2015-002-1 Facility Study includes a loadflow analysis, short circuit analysis and stability analysis.

The Loadflow Analysis documents the steady-state performance of the network following the generation interconnection projects. The loadflow analysis was split into three phases.

Phase 1 of the loadflow analysis was a system intact and N-1 contingency analysis of the Nebraska transmission system in accordance with NERC Standard TPL-001-4. The Phase 1 screening did not identify any significantly impacted NPPD facilities for system intact conditions. Two facilities were found to overload for N-1 conditions:

<u>Facility</u>	<u>Contingency</u>	<u>Rating (MVA)</u>	<u>Loading</u>
Belvidere-Fairbury 115kV	McCool-Moore 345kV	99	107.9%
Belvidere-Fairbury 115kV	Tobias-Moore 345kV	99	104.5%
Beatrice-Harbine 115kV	Knob Hill-Steel City 115kV	99	103.1%

The Phase 1 screening did not discover any impacted bus voltages outside of limits for system intact or N-1 conditions.

Phase 2 of the loadflow analysis involved a comprehensive multiple element contingency analysis of the Nebraska transmission system in accordance with NERC Standard TPL-

001-4. The Phase 2 screening identified several NPPD facilities that were loaded in excess of facility ratings for multiple element contingencies. Each of the contingencies and overloaded facilities may require curtailment of firm transmission and/or load shed to mitigate these issues. Five facilities in the WAPA system were found to overload for multiple element contingency conditions. SPP and WAPA will need to assess and address these issues as necessary. The Phase 2 screening did not discover any impacted bus voltages outside of limits for multiple element contingency conditions.

Phase 3 of the loadflow analysis evaluated the impacts of worst case independent N-2 double contingency conditions for the local area transmission outlet paths associated with the generation interconnection projects. This phase did identify several independent N-2 contingencies that would require prior outage generation limitations of the proposed generation interconnection projects. These prior outage limitations would be developed through an operational study and/or operational guides if the projects continue to be developed. The limiting prior outages are listed below:

Limiting Prior Outage Facilities

1.	HEBRN N7	115.00-HEBRON 7	115.00
2.	BEATRCE7	115.00-HARBINE7	115.00
3.	HOSKINS3	345.00-HOSKINS4	230.00
4.	HOSKINS3	345.00-ANTELOPE	3345.00
5.	ANTELOPE	3345.00-ANTELOPE	7115.00
6.	PETRSBG7	115.00-PETERSBRG.N7	115.00
7.	CARLJCT7	115.00-HEBRN N7	115.00
8.	G15087_T	115.00-HEBRN N7	115.00
9.	BELDEN 7	115.00-TWIN CH7	115.00
10.	HARTGTN7	115.00-GAVINS 7	115.00
11.	BELDEN 7	115.00-HOSKINS7	115.00
12.	AXTELL 3	345.00-PAULINE3	345.00
13.	FAIRBRY7	115.00-HARBINE7	115.00
14.	MCCOOL 3	345.00-MOORE 3	345.00
15.	G15088_T	345.00-MOORE 3	345.00
16.	BLMFLD 7	115.00-CREITON7	115.00
17.	TWIN CH4	230.00-TWIN CH7	115.00
18.	KNOB HL3	115.00-STEELEC7	115.00
19.	G10-51T	230.00-TWIN CH4	230.00
20.	ALBION 7	115.00-PETRSBG7	115.00
21.	BLMFLD 7	115.00-GAVINS 7	115.00
22.	BELDEN 7	115.00-HARTGTN7	115.00
23.	BATTLER7	115.00-NORFK.N7	115.00
24.	BATTLER7	115.00-CO.LINE7	115.00
25.	CO.LINE7	115.00-ANTELOPE	7115.00
26.	G15087_T	115.00-FAIRBRY7	115.00
27.	G15088_T	345.00-PAULINE3	345.00
28.	ALBION 7	115.00-GENOA 7	115.00

The Short Circuit Analysis was performed to evaluate the fault interrupting capability of existing devices in the area and protection coordination issues following the generation interconnection projects and network upgrades. The results of this analysis showed that no existing protective devices were subject to replacement due to the proposed interconnection projects.

The Stability Analysis was performed to evaluate the impact of the proposed generation interconnection projects and network upgrades on the existing GGS Stability constrained interface in Nebraska. Based on the results of this analysis, the NPPD transmission system with the current planned future projects meets the stability performance requirements for all Planning Event and Extreme Event conditions that were considered in this study.

Overall, the *NPPD DISIS-2015-002-1 Facility Study* documents the performance of the network following the addition of the generation interconnection projects and network upgrades. The Facility Study has documented the transmission plan required for interconnection to the NPPD transmission system and the details of this plan are listed below. There is no generation interconnection capability available until the projects listed below are completed as required.

DISIS-2015-002-1 Interconnection Plan

Interconnection Facilities

- GEN-2015-053: Expand Antelope 115 kV Substation to accommodate new GI.

\$ 2,900,000
- GEN-2015-076: Expand Belden 115 kV Substation to accommodate new GI.

\$ 3,200,000
- GEN-2015-087: Construct Belvidere 115 kV Substation to accommodate new GI.

\$ 5,600,000
- GEN-2015-088: Construct Tobias 345 kV Substation to accommodate new GI.

\$ 12,400,000

Network Upgrades

- Re-Conductor Petersburg North-Petersburg-Albion 115 kV.
\$ 2,500,000
- Uprate Belvidere-Fairbury 115 kV line.
\$ 1,700,000
- Uprate Beatrice-Harbine 115 kV line.
\$ 900,000

Previously-allocated Network Upgrades

- Hoskins – Neligh (Antelope) 345/115 kV Transmission expansion project
- Gentleman – Thedford - Holt County (R-Project) and Thedford 345/115 kV Transformer project

Previously-identified Required Transmission Upgrades for prior queued requests

- Dixon County 230 kV substation (for GEN-2010-051)
- Upgrade Twin Church-DixonCounty-Hoskins 230kV line
- Antelope 115 kV substation expansion (for GEN-2013-032)
- Upgrade Antelope-County Line-Battle Creek 115 kV line
- Upgrade Meadow Grove-Prairie Breeze 230 kV Gen-Tie line
- Friend 115 kV substation (for GEN-2014-039)
- Rosemont 115 kV substation (for GEN-2008-123N)
- Hoskins 345 kV substation expansion (for GEN-2015-007)
- Holt County 345 kV substation expansion (for GEN-2015-023)

1.0 Introduction

In September 2016, NPPD was notified that several generation interconnection requests in the SPP generation interconnection queue had advanced to the facility study stage. These generation interconnection requests were evaluated by SPP in multiple Definitive Interconnection System Impact Studies (DISIS-2015-002, DISIS-2015-002-1). The generation interconnection requests are listed below:

<u>Project</u>	<u>MW</u>	<u>Type</u>	<u>Point-of-Interconnection</u>
GEN-2015-053	+50.0	Wind	Antelope 115 kV Substation
GEN-2015-076	+158.4	Wind	Belden 115 kV Substation
GEN-2015-087	+66.0	Wind	Belvidere 115 kV Substation
GEN-2015-088	+300.0	Wind	Tobias 345 kV Substation
	+574.4		

SPP entered into a facility study agreement with each of the generation interconnection customers and subsequently requested that NPPD perform the Facility Study for each request. In response to the SPP request, NPPD has performed a Facility Study for the generation interconnection requests.

This facility study (NPPD-DISIS-2015-002-1) includes a detailed loadflow, stability and short circuit analysis. The Facility Study also includes detailed cost estimates and estimated project schedules for the interconnection and network upgrades identified in the System Impact Study and Facility Study. The System Impact Study did identify several network upgrades required for interconnection of the new generation projects. Both of these generation interconnection requests are contingent upon the completion of the Hoskins-Neligh 345 kV projects and the GGS-Thedford-Holt 345 kV R-project which were previously approved through the SPP ITP processes. The GGS-Thedford-Holt 345 kV R-project is being developed and slightly behind the original project schedule. The current projected in-service date for the R-project is 10/1/2019.

2.0 Study Scope

2.1 Overview

This Facility Study will evaluate the impact of the requested generation interconnection projects on the NPPD transmission system. This study will evaluate generator interconnection requests in the SPP Generator Interconnection Queue studied in the SPP Definitive Interconnection System Impact Study, SPP DISIS-2015-002-1, and progressed to the facilities study stage. The GI projects on the NPPD transmission system included in the DISIS-2015-002-1 study are as follows:

<u>Project</u>	<u>MW</u>	<u>Type</u>	<u>Point-of-Interconnection</u>
GEN-2015-053	+50.0	Wind	Antelope 115 kV Substation
GEN-2015-076	+158.4	Wind	Belden 115 kV Substation
GEN-2015-087	+66.0	Wind	Belvidere 115 kV Substation
GEN-2015-088	+300.0	Wind	Tobias 345 kV Substation
	+574.4		

NPPD will perform a Facility Study of the generation interconnection requests that includes a detailed loadflow and short circuit analysis. The facility study will also include stability analysis to assess the impacts of the proposed generation interconnection requests on existing stability constraints (GGS Eastflow) and potential stability issues highlighted in the System Impact Study. The Facility Study also includes detailed cost estimates and estimated project schedules for the interconnection and network upgrades identified in the System Impact Study and Facility Study. All of these generation interconnection requests are contingent upon the completion of the GGS-Theford-Holt 345 kV R-projects which were previously approved through the SPP ITP processes. The following network upgrades are also required per the System Impact Study:

- Uprate and rebuild of the Albion-Petersburg-Petersburg North 115 kV line (GEN-2015-053)
- Uprate and rebuild of the Gavins Point – Yankton Junction 115 kV line (GEN-2015-076) – WAPA/COE Upgrade

At the time of this facility study, there were several active generation interconnection requests in the SPP GI queue in the Nebraska area. Due to time constraints, this facility study must proceed assuming the following generation interconnection projects and associated network upgrades remain active projects in the SPP GI process. If any of these GI projects or network upgrades withdraw from the SPP GI queue, then a re-study of this DISIS-2015-002-1 facility study will be required. The previously-queued GI projects and network upgrades in the Nebraska area are as follows:

Generation Interconnection Number	MW	CA	Substation	Status
GEN-2010-051	200	NPPD	Dixon County 230kV	IA FULLY EXECUTED/ON SCHEDULE
GEN-2011-027	120	NPPD	Dixon County 230kV	IA FULLY EXECUTED/ON SCHEDULE
GEN-2013-032	204	NPPD	Antelope 115kV	IA FULLY EXECUTED/ON SCHEDULE
GEN-2014-032	10.2	NPPD	Meadow Grove 230kV	IA FULLY EXECUTED/ON SCHEDULE
GEN-2014-039	73.4	NPPD	Friend 115kV	IA FULLY EXECUTED/ON SCHEDULE
GEN-2008-123N	89.7	NPPD	Rosemont 115kV	IA FULLY EXECUTED/ON SCHEDULE
GEN-2015-007	160	NPPD	Hoskins 345 kV	IA PENDING
GEN-2015-023	300.7	NPPD	Holt County 345kV	IA PENDING

Previously allocated interconnection facilities & network upgrades

- Dixon County 230 kV substation (for GEN-2010-051)
- Upgrade Twin Church-DixonCounty-Hoskins 230kV line
- Antelope 115 kV substation expansion (for GEN-2013-032)
- Upgrade Antelope-County Line-Battle Creek 115 kV line
- Upgrade Meadow Grove-Prairie Breeze 230 kV Gen-Tie line
- Friend 115 kV substation (for GEN-2014-039)
- Rosemont 115 kV substation (for GEN-2008-123N)
- Hoskins 345 kV substation expansion (for GEN-2015-007)
- Holt County 345 kV substation expansion (for GEN-2015-023)

This facility study will assess the new system state with the generation interconnection requests. The facility study will also identify any additional transmission issues that would require mitigation to meet mandatory NERC reliability standards following the addition of the generation interconnection projects and network upgrades. The Facility Study will include the following study phases:

1. Loadflow Analysis
2. Stability Analysis
3. Short Circuit Analysis

The loadflow analysis will be an assessment of the transmission system following the addition of the generation interconnection projects and network upgrades. The loadflow analysis will evaluate the transmission system for compliance with NERC Reliability Standards and identify any thermal and voltage issues that would require mitigation. The stability analysis will evaluate the impacts of the generation interconnection projects on the transmission system and existing stability constraints (GGS Eastflow). The short circuit analysis will evaluate the impacts of the generation interconnection project and network upgrades on existing fault currents in the area and determine if the capability of existing fault interrupting devices are adequate.

The intent of the facility study is to perform a detailed assessment of the proposed generation interconnection facility and associated transmission and validate adherence to system reliability criteria. This study will be performed in accordance with NERC Reliability Standards and the criteria set forth under those standards. This facility study will document the required transmission facility interconnection plan for the proposed uprate and will be performed in accordance with the methodologies described in NPPD's Facility Connection Requirements Document.

2.2 Loadflow Analysis

NPPD Transmission Planning will perform a loadflow analysis to screen the steady state performance of the network following the addition of the generation interconnection project and network upgrades. The powerflow models used for the loadflow analysis will be 2015 Series SPP MDWG models. These models will represent expected near-term system conditions with the generation interconnection projects and will represent worst-case seasonal conditions. The powerflow models utilized for the analysis will be:

2016 Spring Load Case (16G)
2016 Light Load Case (16L)
2016 Summer Peak Case (16S)
2016-17 Winter Peak Case (16W)

The base SPP MDWG powerflow models will be updated with planned transmission facility additions in the area of the generation interconnection requests. Specifically, the base models will be updated to include the GGS-Thedford-Holt 345 kV project as it was found to be a required network upgrade to accommodate the generation interconnection projects. Also, the models were updated to include the Nebraska City – Mullin Creek – Sibley 345 kV project in eastern Nebraska.

The loadflow analysis will be split into three phases:

Phase 1 : System-wide Single Contingency N-1 Analysis (P1)

Phase 2 : System-wide Multiple Element Contingency N-2 Analysis (P2-P7)

Phase 3 : Local Area Full N-2 Contingency Analysis

PHASE 1: This Phase is considered a comprehensive single contingency analysis of the entire Nebraska subregion. Every single element rated from 115 kV – 345 kV in the NPPD, OPPD, and LES areas plus ties will be outaged and monitored through activity ACCC. The results of the contingency screening will be assessed and documented.

Phase 1 will also further investigate all critical contingencies identified from the ACCC contingency screening. Phase 1 will be utilized to document the performance characteristics of the system in accordance with NERC Reliability Standards.

PHASE 2: This Phase is considered a comprehensive multiple element contingency analysis of the entire Nebraska region. Multiple element contingencies rated from 115 kV – 345 kV will be outaged and monitored through activity ACCC. The multiple element contingencies consist of stuck breaker contingencies and double circuit tower contingencies identified by Nebraska transmission owners and utilized during MRO and SPP screening processes. The results of the contingency screening will be assessed and documented. Phase 2 will also further investigate all critical contingencies identified from the ACCC contingency screening comparison. Phase 2 will be utilized to document the performance characteristics of the system in accordance with NERC Reliability Standards.

PHASE 3: This Phase will evaluate the impacts of worst case independent N-2 double contingency conditions for the local area transmission outlet paths associated with the generation interconnection projects. The purpose of this Phase will be to evaluate sufficient generator outlet transmission capacity for the generation interconnection requests and evaluate potential prior outage limitations.

2.3 Stability Analysis

The purpose of the Stability Analysis will be to evaluate the impacts of the proposed generation interconnection projects on an existing stability constraint on the NPPD transmission system (GGS Eastflow). The analysis will evaluate worst-case disturbances impacting stability limitations in western Nebraska. The analysis will also evaluate disturbances and prior outage combinations near the proposed generation interconnection projects to evaluate any potential stability issues.

2.4 Short Circuit Analysis

The purpose of the Short Circuit Analysis will be to evaluate the impacts of the proposed generation interconnection projects on the existing substation equipment fault duty ratings in the area. The substations to be evaluated are those electrically close to the interconnection points of the generation interconnection projects.

The Short Circuit Analysis will include short circuit calculations, an evaluation of the adequacy of existing circuit breaker interrupting ratings and an evaluation of the adequacy of the fault withstand capability of other substation equipment located at the monitored substations. The Short Circuit Analysis will be performed by NPPD Engineering Protection & Control personnel.

2.5 Detailed Cost Estimates & Project Schedule

NPPD Engineering, Asset Management, and Project Management departments will review any additional transmission upgrades identified in the SPP DISIS-2015-002-1 facility study. Detailed cost estimates and project schedules will be developed by these groups to implement the proposed transmission upgrades using standard NPPD construction and procurement practices. If any additional transmission upgrades are identified in this facility study, a detailed cost estimate and project schedule for these additional upgrades will be developed and provided as required.

3.0 Model Development

Overview

This study was conducted using Power Technology Inc.’s (PTI’s) Power System Simulator (PSS/E) software package and the following SPP 2015 Series MDWG powerflow models:

- 2016 Spring Peak Load Case
- 2016 Light Load Case
- 2016 Summer 100% Peak Load Case
- 2016-17 Winter 100% Peak Load Case

The powerflow models were updated to include the generation interconnection projects and network upgrades as well as the latest transmission upgrades documented in the latest regional transmission plans. Specifically, the base models were updated to include the GGS-Thedford-Holt 345 kV project as it was found to be a required network upgrade to accommodate the generation interconnection projects. Also, the models were re-dispatched to ramp up wind generation and adjacent generators to the new proposed generation interconnection locations. The 16W case was also re-dispatched to stress transfer limitations in western Nebraska and the GGS Stability Interface. A base 16W model was established with GGS Eastflow at the 1850 MW transfer level with the projected system topology for 2016 (without the R-Project). The prior-queued wind generation, R-Project, and DISIS-2015-002 wind projects were then added to this model to establish the baseline for the stability analysis.

The following prior-queued generation interconnection projects were included in the base powerflow models:

Generation Interconnection Number	MW	CA	Substation	Status
GEN-2010-051	200	NPPD	Dixon County 230kV	IA FULLY EXECUTED/ON SCHEDULE
GEN-2011-027	120	NPPD	Dixon County 230kV	IA FULLY EXECUTED/ON SCHEDULE
GEN-2013-032	204	NPPD	Antelope 115kV	IA FULLY EXECUTED/ON SCHEDULE
GEN-2014-032	10.2	NPPD	Meadow Grove 230kV	IA FULLY EXECUTED/ON SCHEDULE
GEN-2014-039	73.4	NPPD	Friend 115kV	IA FULLY EXECUTED/ON SCHEDULE
GEN-2008-123N	89.7	NPPD	Rosemont 115kV	IA FULLY EXECUTED/ON SCHEDULE
GEN-2015-007	160	NPPD	Hoskins 345 kV	IA PENDING
GEN-2015-023	300.7	NPPD	Holt County 345kV	IA PENDING

The proposed future generation interconnection projects were dispatched off-system. The new generation interconnection projects listed below were then added to the models and dispatched at 100%. The total output from the new generation interconnection projects was dispatched off-system.

Generation Interconnection Number	MW	CA	Substation	Status
GEN-2015-053	50	NPPD	Antelope 115 kV	FACILITY STUDY
GEN-2015-076	158.4	NPPD	Belden 115 kV	FACILITY STUDY
GEN-2015-087	66	NPPD	Belvidere 115kV	FACILITY STUDY
GEN-2015-088	300	NPPD	Tobias 345 kV	FACILITY STUDY

Two network upgrades were incorporated into the models with the new generation interconnection projects that were identified in the SPP DISIS report. These network upgrades are listed below:

- Uprate and rebuild of the Albion-Petersburg-Petersburg North 115 kV line (GEN-2015-053)
- Uprate and rebuild of the Gavins Point – Yankton Junction 115 kV line (GEN-2015-076) – WAPA/COE Upgrade

Wind Generation Models

Each of the new wind generation interconnection projects were modeled with a +/- 0.95 power factor range with voltage control capability at the designated point-of-interconnection. Some of the new projects may have a larger reactive power range available, but the reactive capability of each generation interconnection project was limited to +/- 0.95 power factor to match the power factor requirements identified in the system impact study. The dynamics models for the new wind projects were standard PSS/E Type 3 WTG models.

4.0 Study Criteria

The following criteria were used for the Steady-State Analysis:

Facility Loading Criteria

Overloads of equipment are defined as greater than 100% of the normal continuous rating (Rate A).

Voltage Criteria

Normal steady-state voltage levels are defined as 0.95 to 1.05 pu. Emergency steady-state voltage levels are defined as 0.90 – 1.10 pu and may be utilized for less than 30 minutes.

The following criteria were used for the Stability Analysis:

Transient Voltage Criteria

Bus voltage excursions outside the band of 0.70 to 1.2 PU any time after the fault is cleared is considered unacceptable.

Damping Criteria

All significant machine rotor angle oscillations must be positively damped and meet the criteria below. The criteria does not apply to bus voltages. The Damping Factor will be calculated from the "Successive Positive Peak Ratio" (SPPR) of the peak-to-peak amplitude of the rotor oscillation. SPPR and the associated Damping Factor will be calculated as:

$$\text{SPPR} = \text{Successive swing amplitude} / \text{Previous swing amplitude}$$

$$\text{Damping Factor} = (1 - \text{SPPR}) * 100 \text{ (in \%)}$$

The Damping Criteria are as follows (with increased damping required for higher probability events):

$$\text{For Disturbances with faults: SPPR (maximum)} = 0.95$$

$$\text{Damping Factor (minimum)} = 5\%$$

$$\text{For Line Trips: SPPR (maximum)} = 0.90$$

$$\text{Damping Factor (minimum)} = 10\%$$

5.0 Loadflow Analysis

5.1 Phase 1 Results (P0-P1 events)

PSS/E activity ACCC was used as a screening tool on each of the base cases to identify those contingencies which deserve closer study. ACCC analyzed the system by sequentially taking each transmission element greater than 100kV in the NPPD, OPPD, and LES areas out of service. P1 events for each of these areas were also included in this analysis. Transmission facilities in the NPPD, OPPD, and LES areas were then monitored for violations of loading or bus voltage criteria. Contingencies which resulted in facility loadings or bus voltages outside of acceptable limits will be discussed in the summary of each case. The Phase 1 ACCC analysis is performed to assess the performance of the transmission system following the addition of the generation interconnection projects and proposed new network upgrades according to NERC standards.

Phase 1 analysis further addressed contingencies flagged in the screened ACCC run with additional AC powerflow analysis as required. In the NPPD area, there are loadflow solution issues associated with voltage regulation bandwidths. Consequently, most of the capacitors and reactors are modeled as fixed mode switched shunts, which must be manually switched to achieve optimal voltage profiles.

Phase 1 – 2016 Light Load

System Intact Results:

There were no impacted transmission facility overloads or bus voltages outside of limits under system intact or base case conditions.

N-1 Contingency Results:

There were no impacted transmission facility overloads or bus voltages outside of limits that were discovered under N-1 conditions (P1).

Phase 1 – 2016 Spring Peak Load

System Intact Results:

There were no impacted transmission facility overloads or bus voltages outside of limits under system intact or base case conditions.

N-1 Contingency Results:

There were no impacted transmission facility overloads or bus voltages outside of limits that were discovered under N-1 conditions (P1).

Phase 1 – 2016 Summer Peak

System Intact Results:

There were no impacted transmission facility overloads or bus voltages outside of limits under system intact or base case conditions.

N-1 Contingency Results:

There were no impacted transmission facility overloads or bus voltages outside of limits that were discovered under N-1 conditions (P1).

Phase 1 – 2016 Winter Peak

System Intact Results:

There were no impacted transmission facility overloads or bus voltages outside of limits under system intact or base case conditions.

N-1 Contingency Results:

There were two impacted transmission facility overloads that were discovered under N-1 conditions. Both of these transmission facility overloads are near proposed generation interconnection locations and would require mitigation. Two other transmission facility overloads were identified that were mitigated through the use of the Sidney DC RAS.

<u>Facility</u>	<u>Contingency</u>	<u>Rating (MVA)</u>	<u>Loading</u>
Belvidere-Fairbury 115kV	McCool-Moore 345kV	99	107.9%
Belvidere-Fairbury 115kV	Tobias-Moore 345kV	99	104.5%
Beatrice-Harbine 115kV	Knob Hill-Steel City 115kV	99	103.1%
GGs-Ogallala 230kV	GGs-Keystone 345kV	320	106.4% ^A
Sidney-Ogallala 230kV	Sidney-Keystone 345kV	320	134.4% ^A

A - Loading mitigated through implementation of Sidney DC RAS

There were no impacted bus voltages discovered outside of limits under N-1 conditions.

Phase 1 Results Summary

The Phase 1 screening did not identify any significantly impacted NPPD facilities for system intact conditions.

Two facilities were found to overload for N-1 conditions. The 115 kV line from the new Belvedere 115 kV substation to Fairbury 115 kV was found to overload due to the new generation interconnections. The Beatrice – Harbine 115 kV line was also found to overload in this same general area. Both facilities would need to be updated to accommodate the new generation interconnection facilities.

The Phase 1 screening did not discover any impacted bus voltages outside of limits for system intact or N-1 conditions.

5.2 Phase 2 Results (P2-P7 Events)

PSS/E activity ACCC was used as a screening tool on each of the base cases to identify those multiple element contingencies which deserve closer study. ACCC analyzed the system by sequentially taking select multiple element contingencies in the Nebraska area out-of-service. P2-P7 contingency events from these areas were utilized in this analysis. Transmission facilities in the NPPD, OPPD, and LES areas were then monitored for violations of loading or bus voltage criteria. The Phase 2 ACCC analysis is performed to assess the performance of the transmission system following the addition of the generation interconnection projects and proposed new network upgrades according to NERC standards.

Phase 2 – 2016 Light Load

There were no impacted transmission facility overloads or bus voltages outside of limits that were discovered under multiple element contingency conditions.

Phase 2 – 2016 Spring Peak Load

There were no impacted transmission facility overloads or bus voltages outside of limits that were discovered under multiple element contingency conditions.

Phase 2 – 2016 Summer Peak

There was one transmission facility overload that was discovered under multiple element contingency conditions.

<u>Facility</u>	<u>Contingency</u>	<u>Rating (MVA)</u>	<u>Loading</u>
Belden-Twin Church 115kV	P24:230:NPPD:TWIN CH4:2220	110.0	100.7%

There were no impacted bus voltages discovered outside of limits under multiple element conditions.

Phase 2 – 2016 Winter Peak

There were nine transmission facility overloads that were discovered under multiple element contingency conditions. Three of the overloads are on WAPA transmission facilities that would need further review to determine the appropriate mitigation.

<u>Monitored Facility</u>	<u>Contingency</u>	<u>Rating</u>	<u>% Flow</u>
Belvidere-FAIRBRY7 115 CKT 1	P22:115:NPPD:PAULINE7:115KV	99	100.4

FTRANDL4-UTICAJC4 230 CKT 1	P22:230:NPPD:COLMBUS4:NORTH	320	107.4 ^B
FTRANDL4-UTICAJC4 230 CKT 1	P22:230:NPPD:COLMBUS4:SOUTH	320	107.4 ^B
BELDEN 7-TWIN CH7 115 CKT 1	P24:230:NPPD:TWIN CH4:2220	110	107.8
GR ISLD4-GI KU1B WND 2 CKT 2	P42:115:NPPD:BKR-GRI-1396	250	101.5 ^B
BROKENB7-LOUPCTY7 115 CKT 1	P42:230:NPPD:BKR-CC-2204	120	102.4
GENTLMN3-GGS T2 WND 2 CKT 2	P42:345:NPPD:BKR-GGS-3304	336	106.5
GENTLMN3-GGS T1 WND 2 CKT 1	P42:345:NPPD:BKR-GGS-3316	336	158.8 ^A
GENTLMN4-OGALALA4 230 CKT 1	P42:345:NPPD:BKR-GGS-3316	320	102.0 ^A
N.PLATT7-STOCKVL7 115 CKT 1	P42:345:NPPD:BKR-GGS-3322	137	104.0
GR ISLD3-GR ISLD-LNX3 345 CKT Z	P42:345:NPPD:BKR-GGS-3322	720	100.1 ^B
Belvidere-FAIRBRY7 115 CKT 1	P42:345:NPPD:BKR-MOR-3306	99	108.5
Belvidere-FAIRBRY7 115 CKT 1	P42:345:NPPD:BKR-MOR-3310	99	107.9
E.COL. 4-COL.EAST T3 WND 2 CKT 1	P42:345:NPPD:BKR-SC-3306	187	102.0
GR ISLD3-GR ISLD-LNX3 345 CKT Z	P42:345:NPPD:BKR-SW-3308	720	100.4 ^B
GENTLMN4-OGALALA4 230 CKT 1	P71:345:NPPD:TWR-GK-PS	320	128.1 ^A

A - Loading mitigated through implementation of Sidney DC RAS
B - WAPA-owned Facility

There were no impacted bus voltages discovered outside of limits under multiple element conditions.

Phase 2 Results Summary

The Phase 2 screening identified several facilities that were loaded in excess of facility ratings for multiple element contingencies. Each of the contingencies and overloaded facilities may require curtailment of firm transmission and/or load shed to mitigate these issues. Five facilities in the WAPA system were found to overload for multiple element contingency conditions. SPP and WAPA will need to assess and address these issues as necessary. The Phase 2 screening did not discover any impacted bus voltages outside of limits for multiple element contingency conditions.

5.3 Phase 3 Results (N-2 Contingency Analysis)

This phase of the analysis evaluated a select set of independent N-2 contingencies in the local area of the generation interconnection projects. PSS/E activity ACCC was used as a screening tool on the 2016 Winter Peak model with the generation interconnection projects to identify those contingencies which deserve closer study. ACCC analyzed the system by sequentially taking out all independent N-2 contingencies in the local area and monitoring facilities in the NPPD, OPPD, and LES areas for violations of loading or bus voltage criteria.

Phase 3 – (Independent N-2 Contingencies)

There were a number of overloaded transmission facilities discovered in the monitored study areas in the independent N-2 ACCC analysis of the 2016 Spring Peak, Light Load, and Winter Peak cases with the generation interconnection additions. Prior outage generation restrictions would be required to ensure the transmission system is able to be operated reliably when certain transmission lines are taken out-of-service. The generation interconnection project curtailments will be subject to “first on, last off” curtailment priorities and operating guides will need to be developed to ensure the transmission system is operated in accordance with mandatory reliability standards. Based on a review of the N-2 contingencies that were flagged in the ACCC analysis, the following list was prepared of transmission facilities that would need detailed prior outage review or operating guides established if all the projects are developed. These transmission facilities were found to be part of an N-2 contingency pairing that resulted in a facility overload on the NPPD transmission system.

Limiting Prior Outage Facilities

1.	HEBRN N7	115.00-HEBRON 7	115.00
2.	BEATRCE7	115.00-HARBINE7	115.00
3.	HOSKINS3	345.00-HOSKINS4	230.00
4.	HOSKINS3	345.00-ANTELOPE	3345.00
5.	ANTELOPE	3345.00-ANTELOPE	7115.00
6.	PETRSBG7	115.00-PETERSBRG.N7	115.00
7.	CARLJCT7	115.00-HEBRN N7	115.00
8.	G15087_T	115.00-HEBRN N7	115.00
9.	BELDEN 7	115.00-TWIN CH7	115.00
10.	HARTGTN7	115.00-GAVINS 7	115.00
11.	BELDEN 7	115.00-HOSKINS7	115.00
12.	AXTELL 3	345.00-PAULINE3	345.00
13.	FAIRBRY7	115.00-HARBINE7	115.00
14.	MCCOOL 3	345.00-MOORE 3	345.00
15.	G15088_T	345.00-MOORE 3	345.00
16.	BLMFLD 7	115.00-CREITON7	115.00

17.	TWIN CH4	230.00-TWIN CH7	115.00
18.	KNOB HL3	115.00-STEELEC7	115.00
19.	G10-51T	230.00-TWIN CH4	230.00
20.	ALBION 7	115.00-PETRSBG7	115.00
21.	BLMFLD 7	115.00-GAVINS 7	115.00
22.	BELDEN 7	115.00-HARTGTN7	115.00
23.	BATTLCR7	115.00-NORFK.N7	115.00
24.	BATTLCR7	115.00-CO.LINE7	115.00
25.	CO.LINE7	115.00-ANTELOPE	7115.00
26.	G15087_T	115.00-FAIRBRY7	115.00
27.	G15088_T	345.00-PAULINE3	345.00
28.	ALBION 7	115.00-GENOA 7	115.00

Phase 3 Results Summary

There were several independent N-2 contingencies that resulted in overloads and would require prior-outage generation limitations to mitigate the identified issues if all the proposed projects are developed. Future planned outages of the facilities listed above could result in significant curtailment of the output levels for the proposed generation interconnection facilities.

6.0 Short Circuit Study

6.1 Model Development

Computer Programs

The Aspen OneLiner software program was utilized to perform short circuit simulations and studies on the transmission system. Where elements were added to the short-circuit model, best estimates for impedance parameters were used based on available data and typical modeling practices. Short-circuit calculation options used were as follows:

- Flat voltage profile with $V(\text{pu}) = 1.0$
- Generator Impedance = Subtransient
- Ignore loads, transmission line $G+jB$, and shunts with positive sequence values

OneLiner was used to calculate three-phase (3PH) and single-line-to-ground (SLG) system-intact bus fault currents for all system buses associated with interrupting devices being evaluated in this study. For devices that the full bus fault current approached or exceeded the device's interrupting rating, more detailed fault calculations were done, calculating the maximum phase current through the breaker for close-in faults, close-in faults with the remote end open, and bus faults with all other branches to the bus open. The maximum phase current of these faults was recorded. For comparison with the breaker interrupting ratings, maximum phase current was multiplied by a factor of 1.05 to account for the possibility of the system operating at up to the maximum normal operating voltage of 1.05 per-unit.

Base System Model Additions (“Base Case”)

The base system model used by the transmission system protection department as of September 19, 2016 was used as the starting point for the short-circuit model used for this study. The base system model included all projects that were in-service at the time the model was copied. All Nebraska-area generation in the short-circuit model was enabled in order to provide maximum short-circuit current. For the study base case, planned system upgrades in the area of the studied projects and prior-queued large generator interconnections expected to be in-service prior to the projects being studied were added to the base case model. The following table lists the prior-queued large generator interconnections that were added to the base model for this study.

Prior Queued Large Generator Interconnections

Queue Designation	Proposed POI	Capacity (MW)
GEN-2008-123N GEN-2013-014	Rosemont 115 kV (New substation)	89.7
GEN-2010-051	Wakefield 230 kV (New substation)	200
GEN-2011-027	Wakefield 230 kV (New substation)	120
GEN-2013-032	Antelope 115 kV (Expand new substation)	204
GEN-2013-002	New substation tapping L1197 Sheldon – SW 7 th & Bennett	50.6
GEN-2013-019	New substation tapping L1197Sheldon – SW 7 th & Bennett	73.6
GEN-2014-039	Friend 115 kV Substation	73.4
GEN-2015-007	Hoskins 345 kV Substation	160
GEN-2015-023	Holt County 345 kV Substation	300.7

Along with the prior-queued large generator interconnections, system upgrades previously identified to accommodate the prior-queued projects were added to the study model.

In addition to the prior-queued large generator interconnections, planned system upgrades in the area of the studied projects were added to the base model. The planned 345 kV line from GGS – Thedford – Holt County was included with a 345 – 115 kV tie transformer at Thedford 115 kV. The planned 115 kV line from Ord to Broken Bow Wind/Muddy Creek substation was included. The planned Monolith 345 – 115 kV tie adjacent to Mark Moore 345 kV / Sheldon 115 kV was also included.

Model Additions for Projects Being Studied (“Study Case”)

The base-case study model was modified to include the new generation interconnections being considered in this study as well as the system upgrades identified to accommodate this additional generation. The following table lists the large generator interconnections that were added to the study-case model for this study.

Large Generator Interconnections Added to Study Case

Queue Designation	Proposed POI	Capacity (MW)
GEN-2015-053	Antelope 115 kV (Expand substation)	50
GEN-2015-076	Belden 115 kV	158.4
GEN-2015-087	Belvidere 115 kV Substation (New, tap on N Hebron - Fairbury)	66
GEN-2015-088	Tobias 345 kV Substation (New, tap on Pauline - Moore)	300

Network upgrades to the Albion – Petersburg – Petersburg North lines (L1168B and L1368) were modeled with the phase conductor replaced with 556 ACSR.

6.2 Study Methodology

Circuit breaker, circuit switcher, and fuse ratings were identified by querying NPPD’s SAP equipment database and extracting equipment data including short-circuit ratings. Breaker ratings given on an asymmetrical (total current) basis were converted to symmetrical current ratings using an assumed maximum system operating voltage of 1.05 per unit.

The calculated short-circuit current at the equipment bus was extracted from the short-circuit results from Aspen OneLiner and compared against the interrupting device interrupting rating. It is recommended that all equipment be replaced if it is found to be at or above 95% of its interrupting rating and seeing an increase of 1% or more in its interrupting duty as a result of the studied projects.

6.3 Results

The following devices were found to be above 95% of their interrupting rating or short-circuit capability with an increase of 1% due to the addition of the projects considered in this study.

Location - Breaker	Manuf.	Model Number	Interrupting Rating	Max Expected Interrupting (A)	Max Current (% of Rating)	Relative Change (%)
BELDEN 1112	GENERAL ELECTRIC	FK-439-115-1500-3	6520	9294	142.5%	46.0%
SHELDON 1136	WESTINGHOUSE	1150-GM-10000	36511	50932	137.2%	1.7%
SHELDON 1134	WESTINGHOUSE	1150-GM-10000	36511	48896	131.7%	1.7%
SHELDON 1132	WESTINGHOUSE	1150-GM-10000	39845	50932	125.7%	1.7%
SHELDON 1102	WESTINGHOUSE	121-GMA-40	40000	50932	125.2%	1.7%
SHELDON 1106	WESTINGHOUSE	121-GMA-40	40000	50932	125.2%	1.7%
SHELDON 1108	WESTINGHOUSE	121-GMA-40	40000	50932	125.2%	1.7%
SHELDON 1112	MITSUBISHI	100-SFMT-40HE	40000	50932	125.2%	1.7%
SHELDON 1114	WESTINGHOUSE	121-GMA-40	40000	50932	125.2%	1.7%
SHELDON 1118	WESTINGHOUSE	121-GMA-40	40000	50932	125.2%	1.7%
SHELDON 1120	WESTINGHOUSE	121-GMA-40	40000	50932	125.2%	1.7%
SHELDON 1124	MITSUBISHI	100-SFMT-40HE	40000	50932	125.2%	1.7%
SHELDON 1126	WESTINGHOUSE	121-GMA-40	40000	50765	124.8%	1.7%
SHELDON 1116	WESTINGHOUSE	121-GMA-40	40000	49809	122.5%	1.7%
SHELDON 1110	WESTINGHOUSE	121-GMA-40	40000	49251	121.1%	1.7%
SHELDON 1104	WESTINGHOUSE	121-GMA-40	40000	47240	115.9%	1.9%
SHELDON 1122	GENERAL ELECTRIC	FK-121-40000-6	40000	48794	120.1%	1.5%

Belden PCB1112 is planned to be replaced with a new circuit switcher. (NPPD Notification 11022638.) The Sheldon breakers are recommended for replacement with the addition of the new Monolith 345 – 115 kV tie adjacent to the Sheldon substation.

No interrupting device replacements are recommended for replacement as the responsibility of the studied projects.

7.0 Stability Analysis

7.1 Model

The stability case was created from the 2016 Winter Peak power flow base case from the 2015 Series SPP MDWG dynamics package. The power flow base case includes re-dispatched western Nebraska resources to maximum output with the various western NE/SD DC ties flowing at maximum capacity from west to east. The net generation and DC tie dispatch levels are listed below:

GGs #1	=	678.0 MW
GGs #2	=	700.0 MW
Laramie River Station #1	=	570.0 MW
Sidney DC West-to-East	=	200.0 MW
Stegall DC West-to-East	=	110.0 MW
Rapid City DC West-to-East	=	200.0 MW
Kingsley Hydro #1	=	50.0 MW

Additional wind generation to the north and south of NPPD was dispatched to provide a worst-case system bias of west to east across the NPPD system and establish a GGS Eastflow transfer level of 1850 MW. Next, additional prior queued wind generation resources in eastern Nebraska were added to the base model as well as the R-project (GGs-Thedford-Holt County 345 kV). Finally, the new DISIS-2015-002 generation interconnection projects were added to the base model. The following lists the Nebraska area wind generation dispatched in the base model.

GI #	MW	Substation or Line
GEN-2003-021N	59.4	Ainsworth Wind Tap 115kV
GEN-2006-020N	42.0	Bloomfield 115kV
GEN-2006-037N1	75.0	Broken Bow 115kV
GEN-2006-038N005	80.0	Broken Bow 115kV
GEN-2006-038N019	80.0	Petersburg North 115kV
GEN-2006-044N	40.5	North Petersburg 115kV
GEN-2007-011N08	81.0	Bloomfield 115kV
GEN-2008-086N02	201.0	Meadow Grove 230kV
GI-0717	166.0	Grand Prairie 345 kV
GI-0718	234.0	Grand Prairie 345 kV
GEN-2008-123N	89.7	Rosemont
GEN-2010-051	200.0	Tap Twin Church - Hoskins 230kV
GEN-2011-018	73.6	Steele City 115kV
GEN-2011-027	120.0	Tap Twin Church @Hoskins 230kV
GEN-2013-008	1.2	Steele City 115kV
GEN-2013-032	204.0	Antelope 115 kV
GEN-2014-013	73.5	Meadow Grove (GEN-2008-086N2 Sub) 230kV
GEN-2014-031	35.8	Meadow Grove 230kV
GEN-2015-007	160.0	Hoskins 345 kV
GEN-2015-023	300.7	Holt County 345kV substation
GEN-2015-053	50	Antelope 115 kV
GEN-2015-076	158.4	Belden
GEN-2015-087	76	Belvedere
GEN-2015-088	300	Tobias
	2317.4	prior-queued DISIS-2015-002
	584.4	included in DISIS-2015-002
	2901.8	Total Wind

7.2 Results (P1-P7 and Extreme Events)

To assess the impact of the generation interconnection projects, a number of Planning Event and Extreme Event faults were evaluated on the base model. Localized faults near the interconnection locations were considered as well as worst-case faults for the GGS Stability Interface. The stability simulations performed are listed in the table titled, *Disturbance Code Description and Summary Results*. The list of contingencies was developed in accordance with the methodologies described previously in this report. Summary of findings for the disturbances applied in this study can be found in the table. All the NPPD area contingencies listed in the table were performed on the base model. The complete study results are available upon request subject to CEII restrictions. Worst-case critical disturbances that are expected to produce more severe system impacts on the NPPD transmission system were simulated in the stability analysis included in this assessment. Disturbances applicable to NERC Standard TPL-001-4 demonstrated a stable system response with acceptable transient voltage swings for all Planning Events (P1-P7) and Extreme Events that were evaluated. A total of 53 separate disturbance runs were performed for this stability analysis.

7.3 Stability Analysis Summary

Based on the results of this analysis, the NPPD transmission system meets the stability performance requirements for all Planning Event and Extreme Event conditions that were considered in this study.

FAULT CODE	NERC CATEGORY	FAULT DESCRIPTION	2016 WIPK	
			STABILITY RESULTS	VOLTAGE RESULTS
2008	P1.2	3PH FAULT ON GENTLMN4-N.PLATT4	STABLE	NO TVV
2014	P1.2	3PH FAULT ON HOSKINS4-TWIN CH4	STABLE	NO TVV
2016	P1.2	3PH FAULT ON TWIN CH4-SIOUXCY4	STABLE	NO TVV
2018	P1.2	3PH FAULT ON MEADOWGROVE4-PR BRZ 4	STABLE	NO TVV
2019	P1.2	3PH FAULT ON MEADOWGROVE4-FTRANDL4	STABLE	NO TVV
3001	P1.2	3PH FAULT ON POSTROCK7-AXTELL 3	STABLE	NO TVV
3002	P1.2	3PH FAULT ON MINGO 7-REDWILO3	STABLE	NO TVV
3004	P1.2	3PH FAULT ON RAUN 3-HOSKINS3	STABLE	NO TVV
3005	P1.2	3PH FAULT ON AXTELL 3-PAULINE3	STABLE	NO TVV
3006	P1.2	3PH FAULT ON AXTELL 3-SWEET W3	STABLE	NO TVV
3007	P1.2	3PH FAULT ON COLMB.E3-SHELCRK3	STABLE	NO TVV
3008	P1.2	3PH FAULT ON COLMB.E3-NW68HOLDRG3	STABLE	NO TVV
3010	P1.2	3PH FAULT ON GENTLMN3-KEYSTON3	STABLE	NO TVV
3011	P1.2	3PH FAULT ON GENTLMN3-REDWILO3	STABLE	NO TVV
3012	P1.2	3PH FAULT ON GENTLMN3-SWEET W3	STABLE	NO TVV
3013	P1.2	3PH FAULT ON GENTLMN3-SWEET W3	STABLE	NO TVV
3014	P1.2	3PH FAULT ON HOSKINS3-SHELCRK3	STABLE	NO TVV
3015	P1.2	3PH FAULT ON HOSKINS3-ANTELOPE 3	STABLE	NO TVV
3018	P1.2	3PH FAULT ON MCCOOL 3-GR ISLD3	STABLE	NO TVV
3019a	P1.2	3PH FAULT ON MOORE 3-TOBIAS 3	STABLE	NO TVV
3019b	P1.2	3PH FAULT ON TOBIAS 3-PAULINE3	STABLE	NO TVV
3020	P1.2	3PH FAULT ON SWEET W3-GR ISLD3	STABLE	NO TVV
3021	P1.2	3PH FAULT ON HOLT.CO3-THEDFRD3	STABLE	NO TVV
3022	P1.2	3PH FAULT ON HOLT.CO3-GRPRAR1-LNX3	STABLE	NO TVV
3023	P1.2	3PH FAULT ON HOLT.CO3-GR ISLD3	STABLE	NO TVV
3024	P1.2	3PH FAULT ON GENTLMN3-THEDFRD3	STABLE	NO TVV
3025	P1.2	3PH FAULT ON GRPRAR2-LNX3-FTTHOM2-LNX33	STABLE	NO TVV
2020	P1.2	3PH FAULT ON HOSKINS4-G10-51T	STABLE	NO TVV
2021	P1.2	3PH FAULT ON G10-51T-TWIN CH4	STABLE	NO TVV
4009	P1.3	3PH FAULT ON HOSKINS T1	STABLE	NO TVV
4023	P1.3	3PH FAULT ON HOSKN T4	STABLE	NO TVV
4029	P1.3	3PH FAULT ON ANTELOPE T1	STABLE	NO TVV
4033	P1.3	3PH FAULT ON GGS T2	STABLE	NO TVV
4034	P1.3	3PH FAULT ON GI KU3A	STABLE	NO TVV
4035	P1.3	3PH FAULT ON HOSKINS T2	STABLE	NO TVV

FAULT CODE	NERC CATEGORY	FAULT DESCRIPTION	2016 WIPK	
			STABILITY RESULTS	VOLTAGE RESULTS
4036	P1.3	3PH FAULT ON SHELLCREEKT1	STABLE	NO TVV
7154	P4.2	SLG Fault on GENTLMN3-SWEET W3; Delayed Clear; GENTLMN3-THEDFRD3	STABLE	NO TVV
7005	P4.2	SLG Fault on GENTLMN3-SWEET W3; Delayed Clear; GENTLMN3-REDWILO3	STABLE	NO TVV
7008	P4.2	SLG Fault on GENTLMN3-KEYSTON3; Delayed Clear; GGS T2	STABLE	NO TVV
7017	P4.2	SLG Fault on GENTLMN4-N.PLATT4; Delayed Clear; N.PLATT4-GENTLMN4	STABLE	NO TVV
7020	P4.2	SLG Fault on GENTLMN4-OGALALA4; Delayed Clear; GGS T2	STABLE	NO TVV
7071	P4.2	SLG Fault on HOSKINS3-SHELCKR3; DELAYED Clear; HOSKINS T4	STABLE	NO TVV
7072	P4.2	SLG Fault on HOSKINS3-SHELCKR3; DELAYED Clear; HOSKINS T2	STABLE	NO TVV
7073	P4.2	SLG Fault on HOSKINS3-RAUN 3; DELAYED Clear; HOSKINS T2	STABLE	NO TVV
7074	P4.2	SLG Fault on HOSKINS3-RAUN 3; DELAYED Clear; HOSKINS T4	STABLE	NO TVV
7164	P4.2	SLG Fault on HOLT.CO3-GRPRAR1-LNX3; DELAYED Clear; HOLT.CO3-GR ISLD-LNX3	STABLE	NO TVV
7165	P4.2	SLG Fault on HOLT.CO3-GR ISLD-LNX3; DELAYED Clear; HOLT.CO3-THEDFRD3	STABLE	NO TVV
7012	P7.1	SLG Fault on GENTLMN3-SWEET W3 and GENTLMN3-REDWILO3 Double Circuit	STABLE	NO TVV
7024	P7.1	SLG Fault on GENTLMN4-N.PLATT4 and GENTLMN4-N.PLATT4 Double Circuit	STABLE	NO TVV
7077	P7.1	SLG Fault on HOSKINS3-SHELCKR3 and MADISON7-NORFOLK7 Double Circuit	STABLE	NO TVV
7078	P7.1	SLG Fault on HOSKINS3-SHELCKR3 and HOSKINS7-NORFOLK7 Double Circuit	STABLE	NO TVV
7156	Extreme Event	SLG Fault on GENTLMN3-SWEET W3 and GENTLMN3-SWEET W3 Cross Point	STABLE	NO TVV
7160	Extreme Event	SLG Fault on GRPRAR2-LNX3-FTTHOM2-LNX33 and MEADOWGROVE4-FTRANDL4 Cross Point	STABLE	NO TVV
7161	Extreme Event	SLG Fault on HOSKINS3-RAUN 3 and HOSKINS4-TWIN CH4 Cross Point	STABLE	NO TVV

8.0 Detailed Cost Estimates & Project Schedule

NPPD's Engineering, Asset Management, and Project Management groups have reviewed the list of interconnection facility upgrades that are required for DISIS-2015-002-1 projects. Detailed cost estimates have been prepared for the facility upgrades that were identified in the system impact study for the requests. The prepared cost estimates are budgetary level estimates (+75%/-25%) and assume implementation of standard NPPD construction and procurement practices. The cost estimates for the interconnection facilities and network upgrades are below:

Interconnection Facilities

- GEN-2015-053: Expand Antelope 115 kV Substation to accommodate new GI.
\$ 2,900,000
- GEN-2015-076: Expand Belden 115 kV Substation to accommodate new GI.
\$ 3,200,000
- GEN-2015-087: Construct Belvidere 115 kV Substation to accommodate new GI.
\$ 5,600,000
- GEN-2015-088: Construct Tobias 345 kV Substation to accommodate new GI.
\$ 12,400,000

Network Upgrades

- Re-Conductor Petersburg North-Petersburg-Albion 115 kV.
\$ 2,500,000
- Uprate Belvidere-Fairbury 115 kV line.
\$ 1,700,000
- Uprate Beatrice-Harbine 115 kV line.
\$ 900,000

The results of DISIS-2015-002-1 documented that these two requests are contingent on the completion of the following previously-allocated required network upgrades:

- Hoskins – Neligh (Antelope) 345/115 kV Transmission expansion project
- Gentleman – Thedford - Holt County (R-Project) and Thedford 345/115 kV Transformer project

The substation one-line diagrams highlighting the required facility upgrades for each generator interconnection are on the following pages. NPPD will work with the generation interconnection projects to develop project schedules for the interconnection facilities and network upgrade projects listed above during the development of the generation interconnection agreement. Typical implementation schedules for new transmission lines (≥ 115 kV) are roughly 4 years or longer to accommodate the public routing process and construction schedules. Substation additions require less land acquisition and typically can be implemented in less time or approximately 2-3 years. Project schedule details will be further discussed in the development of the generator interconnection agreement (GIA) and the milestones associated with the generation interconnection projects.

It should also be noted that the interconnection plan for the DISIS-2015-002-1 generation projects are dependent on the transmission upgrades/additions that are required as part of the previous SPP DISIS GI Studies and SPP ITP Studies. If there are any modifications to these previous studies and related upgrades, then the interconnection plan for the DISIS-2015-002-1 projects could be affected. There is no interconnection capacity for the DISIS-2015-002-1 projects without the previously identified upgrades.

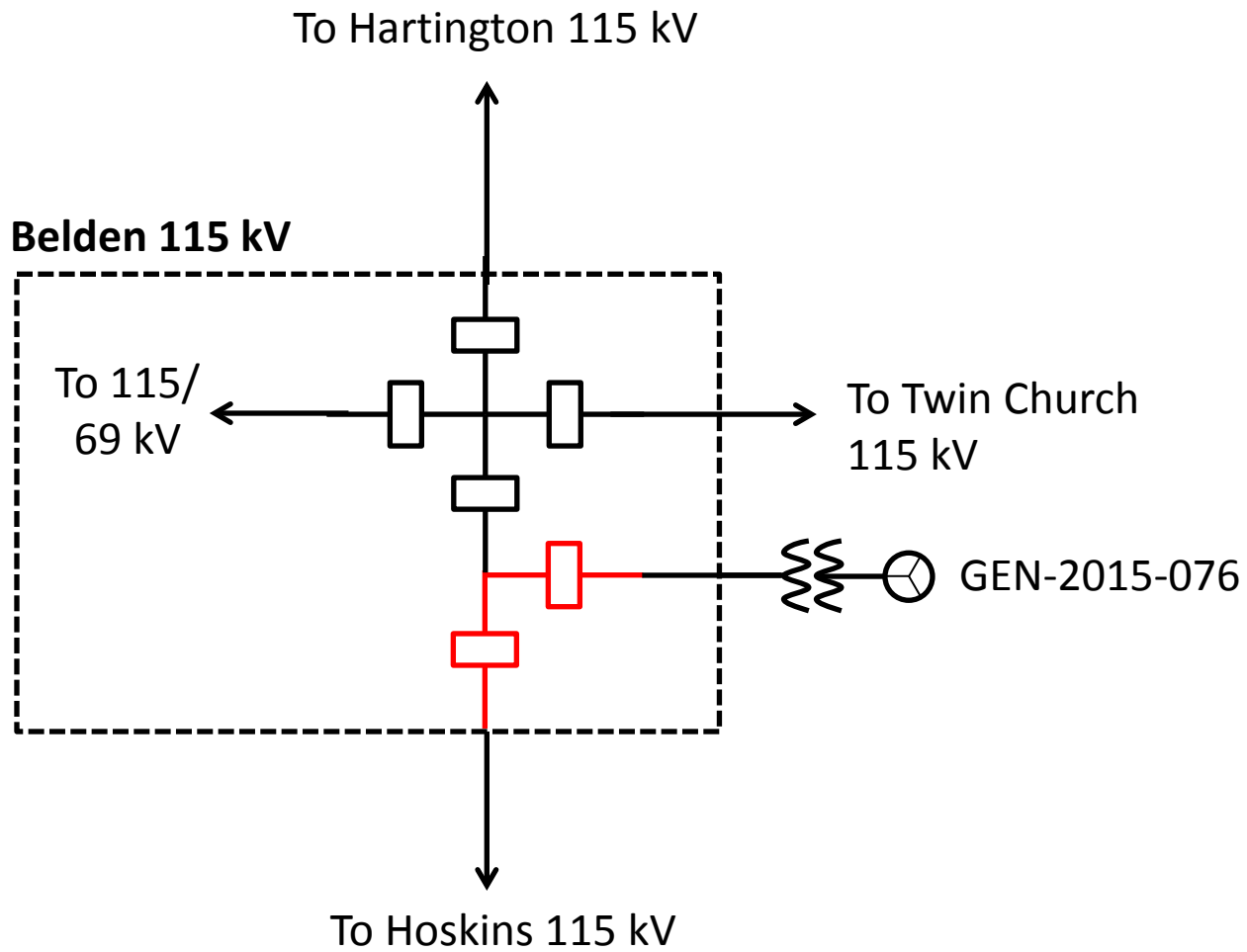

Belvidere 115 kV Substation

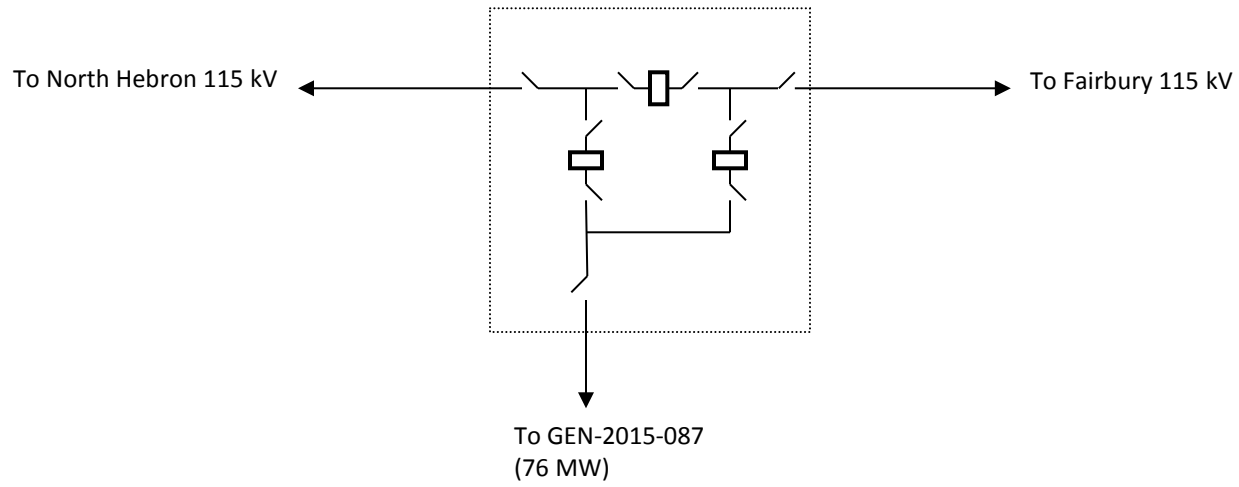

**Neligh East 345/115 kV Substation
(Antelope)**

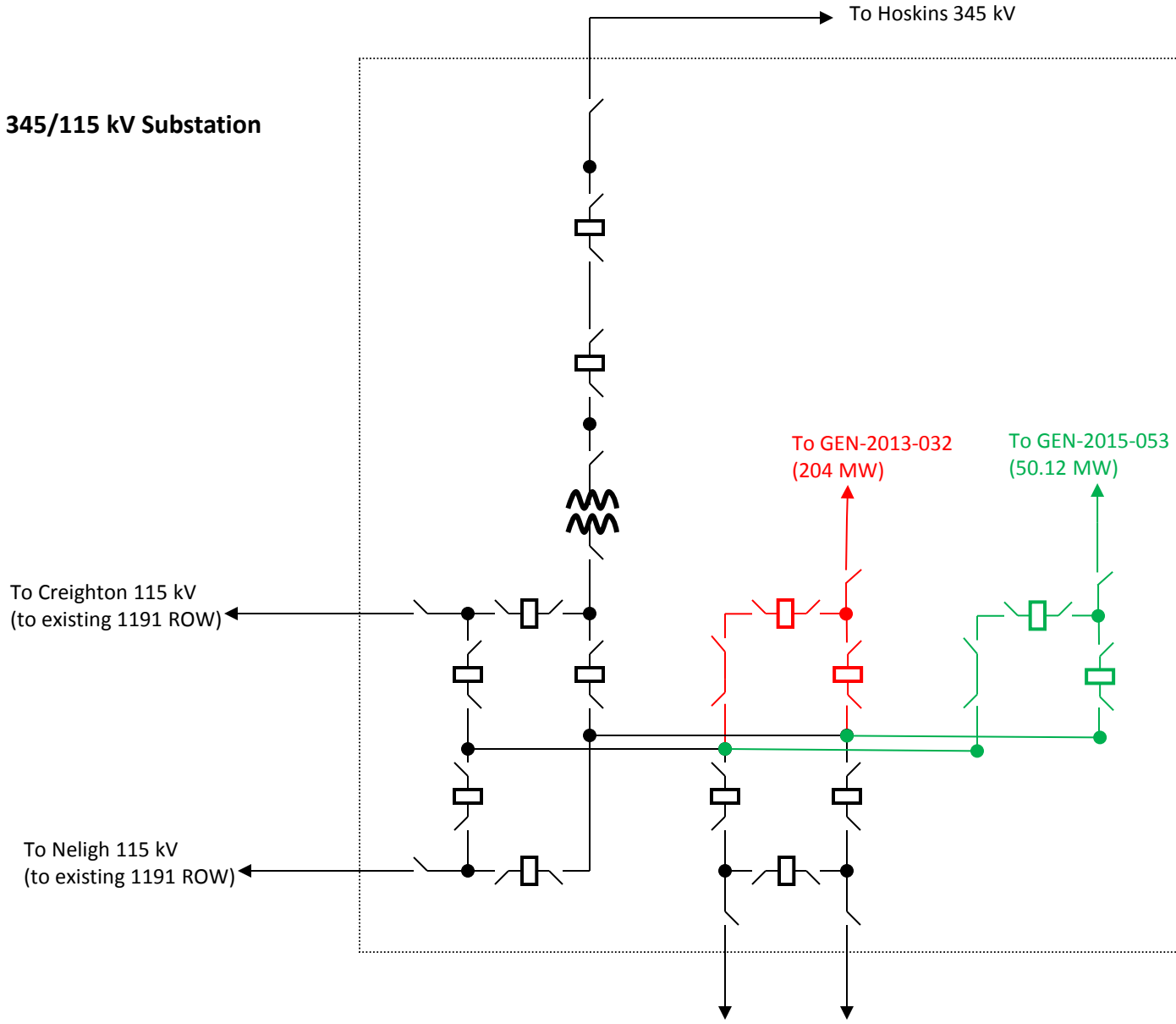

- DISIS-2013-002 Network Upgrades for GEN-2013-032
- DISIS-2015-002 Network Upgrades for GEN-2015-053

To Neligh 115 kV (to existing 1163D ROW) To County Line 115 kV (to existing 1163D ROW)

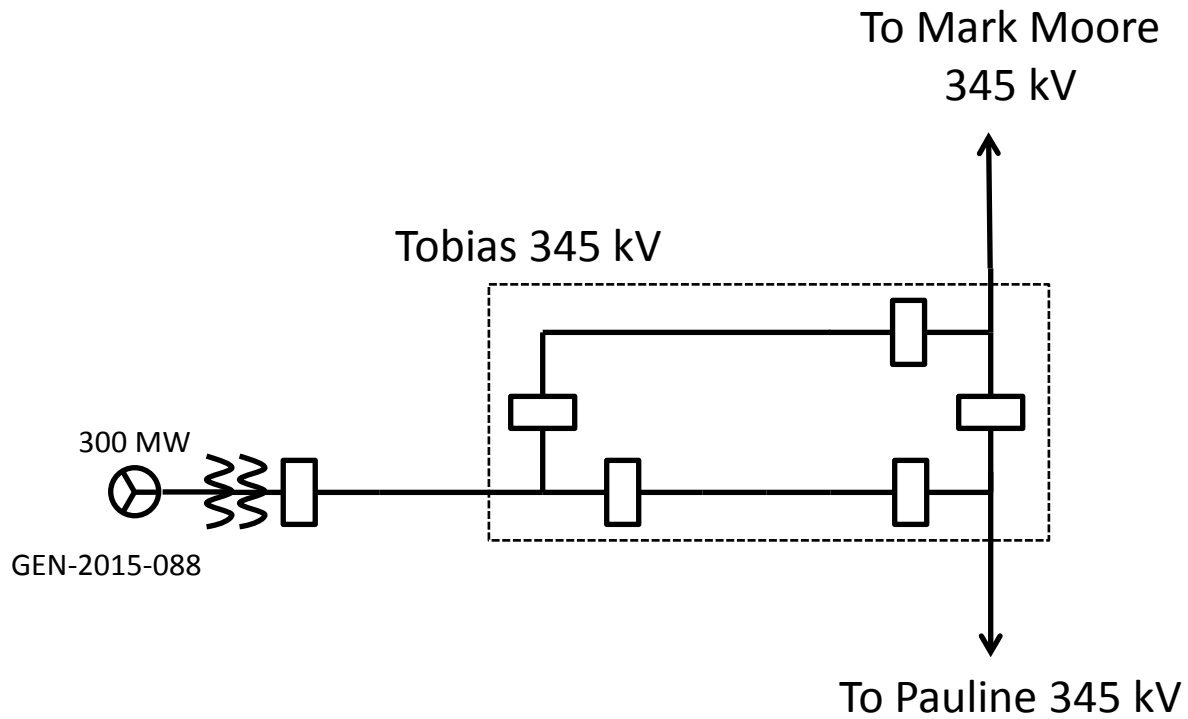

B: AFFECTED SYSTEM FACILITIES STUDY REPORT

See next page for the Affected System Facilities Study Report.

C: CUSTOMER COMMENTS FOR FACILITIES STUDY REPORT

See next page for the Customer Comments.

Customer comments and SPP responses:

The Interconnection Customer (IC) for GEN-2015-087 and GEN-2015-088 requests that SPP investigate the inconsistencies in the facility study report. Specifically the items below:

- IC: There is a disparity between the SPP summary and NPPD results for the studies for GEN-2015-087, and -088
 - *SPP: SPP has reviewed the differences between the SPP summary and NPPD report. The results are consistent with each party's respective model assumptions and scope. Due to the differences in the study results, a Limited Operation Impact Study (LOIS) is warranted to provide clarification on operating amounts prior to the completion of the "R-Plan".*
- IC: There is not clear identification of the model assumptions made by NPPD and these seem inconsistent with the SPP assumptions from the DISIS
 - *SPP: NPPD verified that the "R-Plan" was included within their models and study assumptions.*
- IC: The impact of the R-Plan project on GEN-2015-087, and -088
 - *SPP: SPP is to provide the IC with an LOIS report clearly defining the available interconnection service amount based on the SPP GI criteria by 3/16/2017.*