



INTERCONNECTION FACILITIES STUDY REPORT

GEN-2015-099
(IFS-2016-002-30)

Published February 2020

By SPP Generator Interconnections Dept.

REVISION HISTORY

| DATE OR VERSION NUMBER | AUTHOR | CHANGE DESCRIPTION |
|-------------------------------|---------------|------------------------------|
| 12/19/2019 | SPP | Initial draft report issued. |
| 02/21/2020 | SPP | Final report issued. |
| | | |

CONTENTS

| | |
|---|---|
| Revision History..... | i |
| Summary..... | 1 |
| Introduction | 1 |
| Phase(s) of Interconnection Service | 1 |
| Credits/Compensation for Amounts Advanced for Network Upgrade(s)..... | 1 |
| Interconnection Customer Interconnection Facilities | 2 |
| Transmission Owner Interconnection Facilities and Non-Shared Network Upgrade(s)..... | 3 |
| Shared Network Upgrade(s) | 4 |
| Previous Network Upgrade(s)..... | 6 |
| Affected System Upgrade(s) | 7 |
| Conclusion..... | 7 |
| Appendices..... | 8 |
| A: Transmission Owner’s Interconnection Facilities Study Report and Network Upgrades Report(s) | 9 |

SUMMARY

INTRODUCTION

This Interconnection Facilities Study (IFS) for Interconnection Request GEN-2015-099/IFS-2016-002-30 is for a 73.3 MW generating facility located in Lea County, NM. The Interconnection Request was studied in the DISIS-2016-001 Impact Study and Restudies for Energy Resource Interconnection Service (ERIS). The Interconnection Customer's original requested commercial operation date is 12/31/2018. The commercial operation date was revised in the Facility Study Agreement to 12/31/2019.

The interconnecting Transmission Owner, Southwestern Power Service (SPS) performed a detailed IFS at the request of SPP. The full report is included in Appendix A. SPP has determined that full Interconnection Service will be available after the assigned Transmission Owner Interconnection Facilities (TOIF), Non-Shared Network Upgrades, Shared Network Upgrades, Previous Network Upgrades, and Affected System Upgrades that are required for full interconnection service are completed.

The primary objective of the IFS is to identify necessary Transmission Owner Interconnection Facilities, Network Upgrades, other direct assigned upgrades, cost estimates, and associated upgrade lead times needed to grant the requested Interconnection Service.

PHASE(S) OF INTERCONNECTION SERVICE

It is not expected that Interconnection Service will occur in phases. However, full Interconnection Service will not be available until all Interconnection Facilities and Network Upgrade(s) can be placed in service.

CREDITS/COMPENSATION FOR AMOUNTS ADVANCED FOR NETWORK UPGRADE(S)

Interconnection Customer shall be entitled to compensation in accordance with Attachment Z2 of the SPP OATT for the cost of SPP creditable-type Network Upgrades, including any tax gross-up or any other tax-related payments associated with the Network Upgrades, that are not otherwise refunded to the Interconnection Customer. Compensation shall be in the form of either revenue credits or incremental Long Term Congestion Rights (iLTCR).

INTERCONNECTION CUSTOMER INTERCONNECTION FACILITIES

The Generating Facility is proposed to consist of thirty three (33) Power Electronics HEC 2.220 MW solar inverters for a total generating nameplate capacity of 73.26 MW.

The Interconnection Customer's Interconnection Facilities to be designed, procured, constructed, installed, maintained, and owned by the Interconnection Customer at its sole expense include:

- 34.5 kV underground cable collection circuits;
- 34.5 kV to 115 kV transformation substation with associated 34.5 kV and 115 kV switchgear;
- One (1) 115/34.5 kV step-up transformer to be owned and maintained by the Interconnection Customer at the Interconnection Customer's substation;
- A 1.7 mile overhead 115 kV line to connect the Interconnection Customer's substation to the Point of Interconnection ("POI") at the 115 kV bus at new Transmission Owner substation ("Lipan Substation") that is owned and maintained by Transmission Owner;
- All transmission facilities required to connect the Interconnection Customer's substation to the POI;
- Equipment at the Interconnection Customer's substation necessary to maintain a composite power delivery at continuous rated power output at the high-side of the generator substation at a power factor within the range of 95% lagging and 95% leading in accordance with Federal Energy Regulatory Commission (FERC) Order 827. The Interconnection Customer may use inverter manufacturing options for providing reactive power under no/reduced generation conditions. The Interconnection Customer will be required to provide documentation and design specifications demonstrating how the requirements are met; and,
- All necessary relay, protection, control and communication systems required to protect Interconnection Customer's Interconnection Facilities and Generating Facilities and coordinate with Transmission Owner's relay, protection, control and communication systems.

TRANSMISSION OWNER INTERCONNECTION FACILITIES AND NON-SHARED NETWORK UPGRADE(S)

To facilitate interconnection, the interconnecting Transmission Owner will perform work as shown below necessary for the acceptance of the Interconnection Customer’s Interconnection Facilities.

Table 1 and **Table 2** lists the Interconnection Customer’s estimated cost responsibility for Transmission Owner Interconnection Facilities (TOIF) and Non-Shared Network Upgrade(s) and provides an estimated lead time for completion of construction. The estimated lead time begins when the Generator Interconnection Agreement has been fully executed.

Table 1: Transmission Owner Interconnection Facilities (TOIF)

| Transmission Owner Interconnection Facilities (TOIF) | Total Cost Estimate (\$) | Allocated Percent (%) | Allocated Cost Estimate (\$) | Estimated Lead Time |
|--|---------------------------------|------------------------------|-------------------------------------|----------------------------|
| Transmission Owner Lipan 115 kV level Interconnection Substation: Construct one (1) 115 kV line terminal, line switches, dead end structure, line relaying, communications, revenue metering, line arrester, and all associated equipment and facilities necessary to accept transmission line from Interconnection Customer’s Generating Facility. | \$613,702 | 100% | \$613,702 | 24 Months |
| Total | \$613,702 | | \$613,702 | |

Table 2: Non-Shared Network Upgrade(s)

| Non-Shared Network Upgrades Description | Z2 Type¹ | Total Cost Estimate (\$) | Allocated Percent (%) | Allocated Cost Estimate (\$) | Estimated Lead Time |
|---|----------------------------|---------------------------------|------------------------------|-------------------------------------|----------------------------|
| Transmission Owner Lipan 115 kV level Interconnection Substation: Construct a new 115 kV substation near the Maddox substation on the 115 kV line between Maddox substation and Taylor Switching Station, tentatively named Lipan Substation. The new Lipan substation will be configured in a 3 position ring. The existing Maddox substation would be rebuilt to accommodate an additional line in the substation. | non-creditable | \$6,685,024 | 100% | \$6,685,024 | 24 Months |
| Total | | \$6,685,024 | | \$6,685,024 | |

¹ Indicates the method used for calculating credit impacts under Attachment Z2 of the Tariff.

SHARED NETWORK UPGRADE(S)

The Interconnection Customer's share of costs for Shared Network Upgrades is estimated in **Table 3** below.

Table 3: Interconnection Customer Shared Network Upgrade(s)

| Shared Network Upgrades Description | Z2 Type | Total Cost Estimate (\$) | Allocated Percent (%) | Allocated Cost Estimate (\$) | Estimated Lead Time |
|--|------------|--------------------------|-----------------------|------------------------------|---------------------|
| OKGE: Border 345 kV Capacitive Reactive Support: Install +275 Mvar Capacitor Bank(s) at Border 345kV | creditable | \$5,929,000 | 10.6% | \$627,786 | 24 Months |
| AEP: Oklaunion 345 kV Capacitive Reactive Support: Install +200 Mvar Capacitor Bank(s) at Oklaunion 345kV. | creditable | \$9,453,182 | 10.5% | \$996,039 | 24 Months |
| SPS: Crossroads 345 kV Capacitive Reactive Support: Install +100 Mvar Capacitor Bank(s) at Crossroad 345 kV | creditable | \$7,075,779 | 4.7% | \$331,713 | 12/2020 |
| SPS: Deaf Smith-Plant X 230 kV Rebuild: Rebuild line to achieve minimum system emergency rating of 430 MVA | creditable | \$4,578,401 | 9.7% | \$445,754 | 12/2020 |
| SPS: Newhart-Plant X 230 kV CKT 1 Rebuild: Rebuild line to achieve minimum system intact/emergency rating of 456 MVA | creditable | \$697,514 | 9.4% | \$65,661 | 12/2020 |
| SPS: Curry County-Deaf Smith 115 kV CKT 1 Rebuild: Rebuild line to achieve minimum normal/emergency rating of 90/90 MVA | creditable | \$4,852,215 | 10.2% | \$496,617 | 12/2020 |
| SPS: Tolk East-Tuco 230 kV CKT 1 Rebuild: Rebuild line to achieve minimum normal/emergency rating of 478 MVA | creditable | \$968,567 | 8.1% | \$78,893 | 12/2020 |
| SPS: Tuco 230 kV Capacitive Reactive Power Support: Install +100 MVar at Tuco 230 kV Substation | creditable | \$5,943,138 | 10.6% | \$629,283 | 06/2021 |
| SPS: Deaf Smith 115 kV Capacitive Reactive Power Support: Build 100 MVar at Deaf Smith 115 kV Substation | creditable | \$3,318,137 | 9.8% | \$323,985 | 11/2021 |
| Total | | \$42,815,933 | | \$3,995,731 | |

All studies have been conducted assuming that higher-queued Interconnection Request(s) and the associated Network Upgrade(s) will be placed into service. If higher-queued Interconnection

Southwest Power Pool, Inc.

Request(s) withdraw from the queue, suspend or terminate service, the Interconnection Customer's share of costs may be revised. Restudies, conducted at the customer's expense, will determine the Interconnection Customer's revised allocation of Shared Network Upgrades.

PREVIOUS NETWORK UPGRADE(S)

Certain Previous Network Upgrades are **currently not the cost responsibility** of the Interconnection Customer but will be required for full Interconnection Service.

Table 4: Interconnection Customer Previous Network Upgrade(s)

| Previous Network Upgrade(s) Description | Current Cost Assignment | Estimated In-Service Date |
|---|--------------------------------|----------------------------------|
| <u>SPP NTC 200309 Hobbs - Yoakum 345 kV CKT 1:</u> Construct new 52-mile 345 kV line from Hobbs to Yoakum. | \$87,349,796 | 6/1/2020 |
| <u>SPP NTC 200395 Tuco - Yoakum 345 kV CKT 1:</u> Construct new 107-mile 345 kV line from Tuco to Yoakum. Install any necessary 345 kV terminal equipment at Yoakum associated with new 345/230 kV transformer. | \$123,902,322 | 6/1/2020 |
| <u>SPP NTC 210484 Yoakum 345/230 kV CKT 1 Transformer:</u> Install new 345/230 kV 640 MVA transformer at Yoakum substation. Install any necessary 230 kV terminal equipment. | \$4,703,455 | 6/1/2019 |
| <u>SPP NTC 210507 Eddy County - Kiowa 345 kV CKT 1:</u> Build new 34 mile 345 kV line from Eddy County to Kiowa. | \$63,730,259 | 11/15/2020 |

Depending upon the status of higher- or equally-queued customers, the Interconnection Request’s in-service date is at risk of being delayed or Interconnection Service is at risk of being reduced until the in-service date of these Previous Network Upgrades.

AFFECTED SYSTEM UPGRADE(S)

To facilitate interconnection, the Affected System Transmission Owner will be required to perform the facilities study work as shown below necessary for the acceptance of the Interconnection Customer’s Interconnection Facilities. **Table 5** displays the current impact study costs as part of the Affected System Impact review. The Affected System facilities study could provide revised costs and will provide each Interconnection Customer’s allocation responsibilities for the upgrades.

Table 5: Interconnection Customer Affected System Upgrade(s)

| Affected System Upgrades Description | Total Cost Estimate (\$) | Allocated Share (%) | Allocated Cost Estimate (\$) |
|--------------------------------------|--------------------------|---------------------|------------------------------|
| None | \$0 | N/A | \$0 |
| Total | \$0 | | \$0 |

CONCLUSION

After all Interconnection Facilities and Network Upgrades have been placed into service, Interconnection Service for 73.3 MW can be granted. Interconnection Customer Limited Operation Interconnection Service (LOIS) amount studied in DISIS-2016-002-2 is 0 MW. Full Interconnection Service will be delayed until the TOIF, Non-Shared NU, Shared NU, Previous NU, Affected System Upgrades that are required for full interconnection service are completed. The Interconnection Customer’s estimated cost responsibility for TOIF, Non-Shared NU and Shared NU that is required for full interconnection service is summarized in the table below.

Table 6: Cost Summary

| Description | Allocated Cost Estimate |
|---|-------------------------|
| Transmission Owner Interconnection Facilities | \$613,702 |
| Network Upgrades | \$10,680,755 |
| Total | \$11,294,457 |

A draft Generator Interconnection Agreement will be provided to the Interconnection Customer consistent with the final results of this IFS report. The Transmission Owner and Interconnection Customer will have 60 days to negotiate the terms of the GIA consistent with the SPP Open Access Transmission Tariff (OATT).

APPENDICES

A: TRANSMISSION OWNER'S INTERCONNECTION FACILITIES STUDY REPORT AND NETWORK UPGRADES REPORT(S)

See next page for the Transmission Owner's Interconnection Facilities Study Report and Network Upgrades Report(s).



Facilities Study For Southwest Power Pool (SPP)

GEN-2015-099
Total Output: 73.3 MW
Lea County, New Mexico

Xcel Energy Services, Inc.
Transmission Planning South
Updated 12/17/2019

Executive Summary

The Southwest Power Pool (SPP or Transmission Provider) evaluated the request GEN-2015-099 to interconnect the generation facility to the SPS transmission system in the Definitive Interconnection System Impact Study (DISIS-2016-002), which was completed in December 2019.

GEN-2015-099 requested the interconnection of a 73.3 MW solar energy generation facility, located in Lea County, New Mexico, to the Southwestern Public Service Company (SPS or Transmission Owner) transmission network. To accommodate the Interconnection Customer's (IC) request, SPS will need to build a new 115 kV substation near the SPS Maddox substation on the 115 kV line between Maddox substation and Taylor Switching Station, tentatively named Lipan Substation. The new Lipan substation will be configured in a 3 position ring. The existing SPS Maddox substation would need to be rebuilt to accommodate an additional line in the substation so a new 115 kV substation located nearby is more cost effective and could be accomplished in a faster timeline. After the new SPS Lipan substation is constructed, the IC will connect to the SPS 115 kV bus. The IC is required to build a 115 kV transmission line from their substation facility to the new SPS Lipan substation. The IC will be required to maintain a Power Factor between 0.95 lagging and 0.95 leading at the Point of Interconnection (POI).

SPP requires that each generator shall implement automatic Under Frequency Load Shedding (UFLS) according to the SPP UFLS Plan for SPS found in the Xcel Energy interconnection document for "Large Generation Interconnection Guidelines (>20MW)" found at the following link:

<https://www.transmission.xcelenergy.com/Interconnections>

To fulfill this requirement, coordination with Xcel Energy is required during the under-frequency relay-setting phase for the generation. The IC is required to report their generation off-nominal frequency tripping relay settings to SPP and SPS. SPS specifies that generators shall not trip at frequencies above 58.5 Hz unless exceptions in the Transmission Provider Criteria are met. The IC agrees that the energy generating units installed at this interconnection will not be tripped for under-frequency conditions above 58.5 Hz in compliance with Transmission Provider criteria. This means that the generation subject to this Interconnection Agreement may not trip for under-frequency conditions on the transmission system until all under-frequency load shedding relays have operated. SPS will also require that the IC be in compliance with all applicable criteria, guidelines, standards, requirements, regulations, and procedures issued by the North American Electric Reliability Corporation (NERC), SPP, and the Federal Energy Regulatory Commission (FERC) or their successor organizations.

The IC is responsible for all the cost of the Interconnection Facilities, installation of the direct assigned Transmission Owner Interconnection Facilities (TOIF) which are facilities paid for by the IC but are owned, operated and maintained by SPS; inclusive of all construction required for the IC to interconnect near SPS's Maddox Substation.

The shared network upgrades will be determined at a later date by SPP and may impact the total overall costs for interconnection of the IC.

It is anticipated that the entire process of building the new 115 kV Lipan substation for the acceptance of the IC facility output and the network upgrades allocated to this project will require approximately 24 months to complete after an Interconnection Agreement is signed and an authorization to proceed is received. The IC's cost for the interconnection of this generation facility is shown below in Table 1, with the detailed description of the cost shown in Table 2.

Table 1 – Cost Summary¹

| | |
|--|----------------------------|
| Shared Network Upgrades Total: | \$ See DISIS Report |
| Network Upgrades: | \$ 6,685,024 |
| Transmission Owner Interconnection Facilities: | \$ 613,702 |
| Total: | \$ 7,298,726 |

¹ The cost estimates are 2019 dollars with an accuracy level of ±20%.

General Description of SPS² Facilities

1. **Construction of the new SPS Lipan Substation:** See Appendix A, Figure A-1 for general vicinity location map of the SPS facility.
 - a. **Location:** IC will build a new 115 kV line from their substation to SPS's 115 kV Lipan Substation in Lea Co, NM near structure #12 on the existing SPS 115 kV line from Maddox to Taylor Switching Station.
 - b. **Bus Design:** The new 115 kV substation will be laid out in a 3 position ring at SPS Lipan to accommodate the output from the solar energy facility. The three position ring bus will be built for future expansion of more breakers and/or lines. Appendix A, Figure A-2, shows a preliminary one-line of the new 115 kV at SPS's Lipan Substation, while Figure A-3 shows a typical elevation view of the normal Point of Interconnection (POI).
 - c. **Revenue Metering:** An individual billing meter will be installed at the SPS substation on the line terminal from the IC's substation, which meets the standards: ANSI C12.1 accuracy class 0.2 (3-PT's IEEE C57.13 accuracy class 0.3 and 3-CT's IEEE C57.13 accuracy class 0.15) for full 3-phase 4-wire metering. Pulses out of the billing meter will be sent via SCADA to the Transmission Owner's Control Center in Amarillo, Texas.
 - i. Wind Interconnections: two meters per line terminal will be installed
 1. One will be primary and the other will be a back up
 - ii. Solar Interconnections: a single meter per line terminal will be installed
 - iii. Coal, Natural Gas, hydro, other: a single meter per line terminal will be installed
 - d. **Disturbance Monitoring Device:** A Disturbance Fault Recorder (DFR), capable of recording faults, swings, and long term trending, will be installed to monitor and record conditions in the substation and on the transmission lines. The disturbance equipment shall also be equipped with a GPS time synching clock. This equipment will have communication capability with a dedicated communication circuit. The disturbance equipment will have its own dedicated communications circuit.
 - e. **Remote Terminal Unit (RTU):** A RTU will be utilized for communications with the new IC facilities. A Communication SEL Relay will be utilized for relay communications and other functions as required; these costs will be directly assigned to the IC. The IC will provide and install a RTU for metering and telemetry at the IC's facility as required by the latest Xcel Energy Interconnection Guidelines.
 - f. **Communications:** To meet its Communications obligations, the IC shall be responsible for making arrangements with the local phone company to provide a communication circuit as required by the Transmission Owner. Transmission Owner equipment may include, but is not limited to the following: relay communication equipment, RTU, and disturbance monitoring equipment. Prior to any construction, the IC is required to contact the Transmission Owner substation-engineering department for all communication details and provide detail of the method to be used in communication.

The following communications schematic diagram, which includes communication equipment

² All modifications to SPS facilities will be owned, maintained and operated by SPS

information for the IC, Transmission Provider (Southwest Power Pool) and Transmission Owner (Southwestern Public Service), is provided to assist the Parties as a template.

A schematic outlining the proposed communications is provided below:

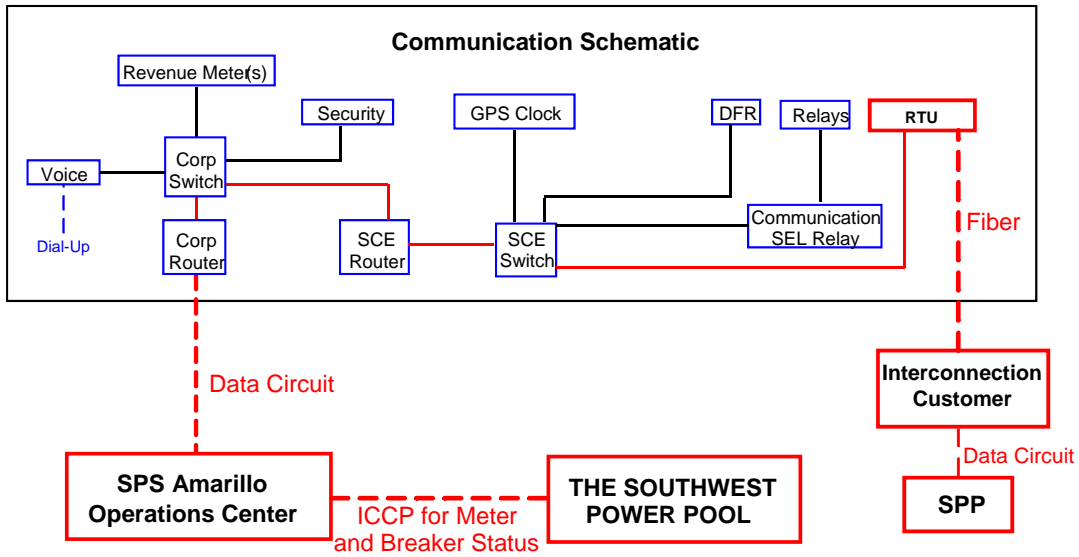

IC shall be responsible for providing the fiber optic communication circuit installed in the overhead transmission line static wire from the customer substation to the SPS substation for protective relaying and for transmitting metering and status data to SPS. Utilizing this fiber optic connection, SPS will establish a direct connection to the IC's RTU.

SPS will not serve as a proxy for communication from the IC to SPP.

2. Transmission Work – Engineering and Construction

- a. **Coordination:** The SPS Transmission Engineering and Design group requires an engineering review of the customer's design prior to any construction by the IC or its contractor on any customer transmission lines or doing work in close proximity to any SPS transmission line. It is the IC's responsibility to initiate the design review in a timely manner before construction of any transmission line begins. If the review has not been made or the design at any of the aforementioned locations is deemed inadequate, the crossing(s) and or termination into the interchange will be delayed until the matters are resolved. SPS will not be held responsible for these delays
- b. **Fault or Short Circuit Study:** The IC will coordinate with the System Protection department at SPS on the available fault current at the interconnection location following the acceptance of the Generator Interconnection Agreement (GIA) and prior to final design on the IC's facilities.
- c. **Schedule:** An engineering and construction schedule for this project is estimated at approximately 24 months. Other factors associated with clearances, equipment delays and work schedules could cause additional delays. This is applicable after all required agreements are signed and internal approvals are granted

3. Right-Of-Way

- a. **Permitting:** The IC will be responsible for any permitting and right of way of their substation and their transmission line from their substation to the Point of Interconnection (POI).
- b. **Construction Power and Retail Service:** It is the sole responsibility of the IC to make arrangements for both construction and station power. The IC needs to make arrangements for retail service from the local retail provider. Retail provider and Customer will be responsible for making any necessary transmission service arrangements as required under the SPP OATT.

4. Project and Operating Concerns:

- a. Close work between the Transmission group, the IC's personnel and local operating groups will be imperative in order to meet any in-service date that has been established.
- b. The IC will be required to maintain a power factor between 0.95 lagging and a 0.95 leading at the Point of Interconnection (POI). All capacitors required will be installed on the lower voltage bus at IC's substation. This is required to maintain acceptable dynamic voltage rise as per latest revision of the Xcel Energy Interconnection Guidelines for Transmission Interconnection Producer-Owned Generation Greater than 20 MW. If switched reactive devices are used on the IC's system, they need to be switched in stages where the voltage rise is less than 3%.

5. Estimated Construction Costs

- a. The projects required for the interconnection of GEN-2015-099 consist of the projects summarized in the table below:

Table 2 - Required Interconnection Projects³

| Project | Description | Estimated Cost |
|---------|--|-------------------------|
| | Shared Network Upgrades: | |
| 1 | The current estimated shared network upgrades to be determined (TBD) | See DISIS Report |
| | | |
| | Network Upgrades (at the IC's expense) | |
| 2 | New 115 kV Lipan Substation | \$ 4,755,281 |
| | Transmission Line Cut-ins | \$ 783,867 |
| | Substation/relaying work at Remote ends | \$ 697,634 |
| | New 115 kV Lipan Substation communications | \$ 448,242 |
| | Subtotal: | \$6,685,024 |
| | Transmission Owner Interconnection Facilities (at the IC's expense) | |
| 3 | Communications ⁴ | \$ See footnote |
| 4 | TOIF | \$ 613,702 |
| | Subtotal: | \$613,702 |
| | Total Cost | \$7,298,726 |

³ The cost estimates are 2019 dollars with an accuracy level of ±20%.

⁴ It is the Requester's responsibility to provide both the data circuit and communication circuits, see Section 1.f

Appendix A

Figure A-1. General vicinity location map of the SPS facility



Figure A-2. One-line Diagram at Maddox Substation

DIAGRAMS ARE NOT FOR CONSTRUCTION PURPOSES

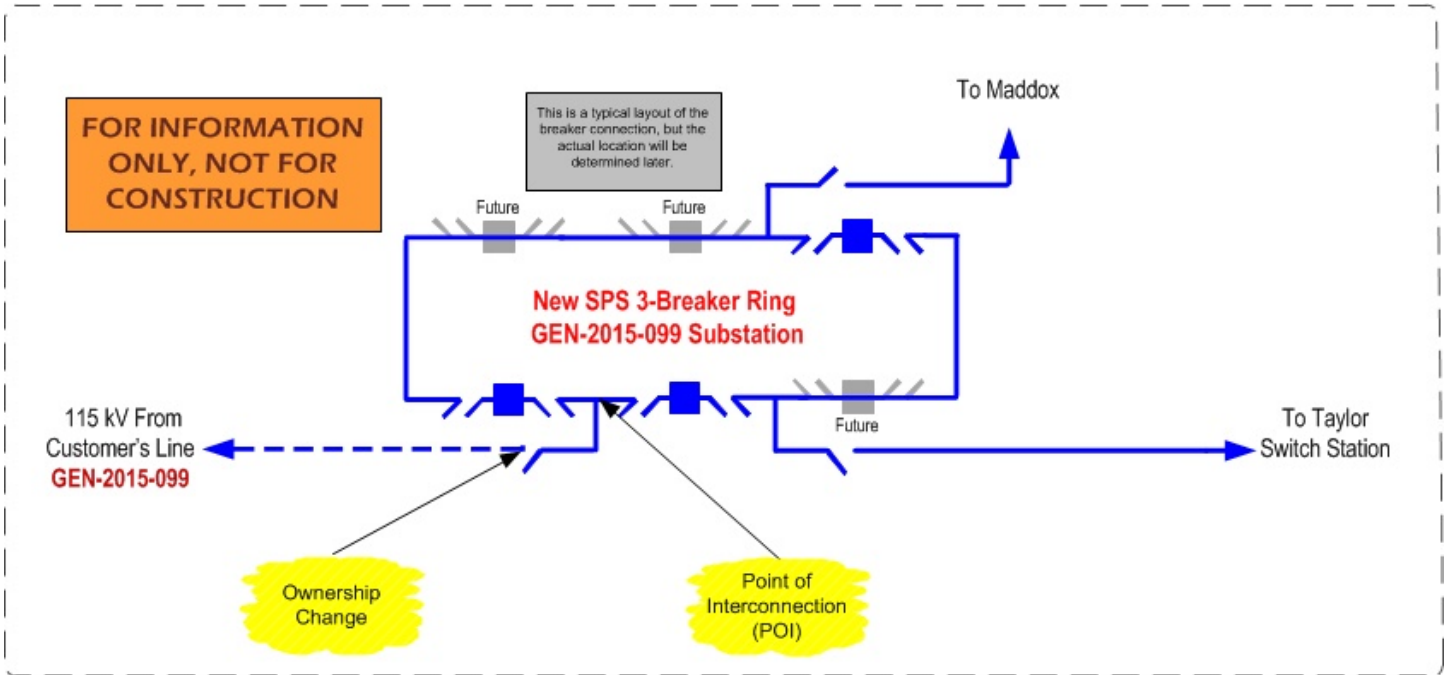
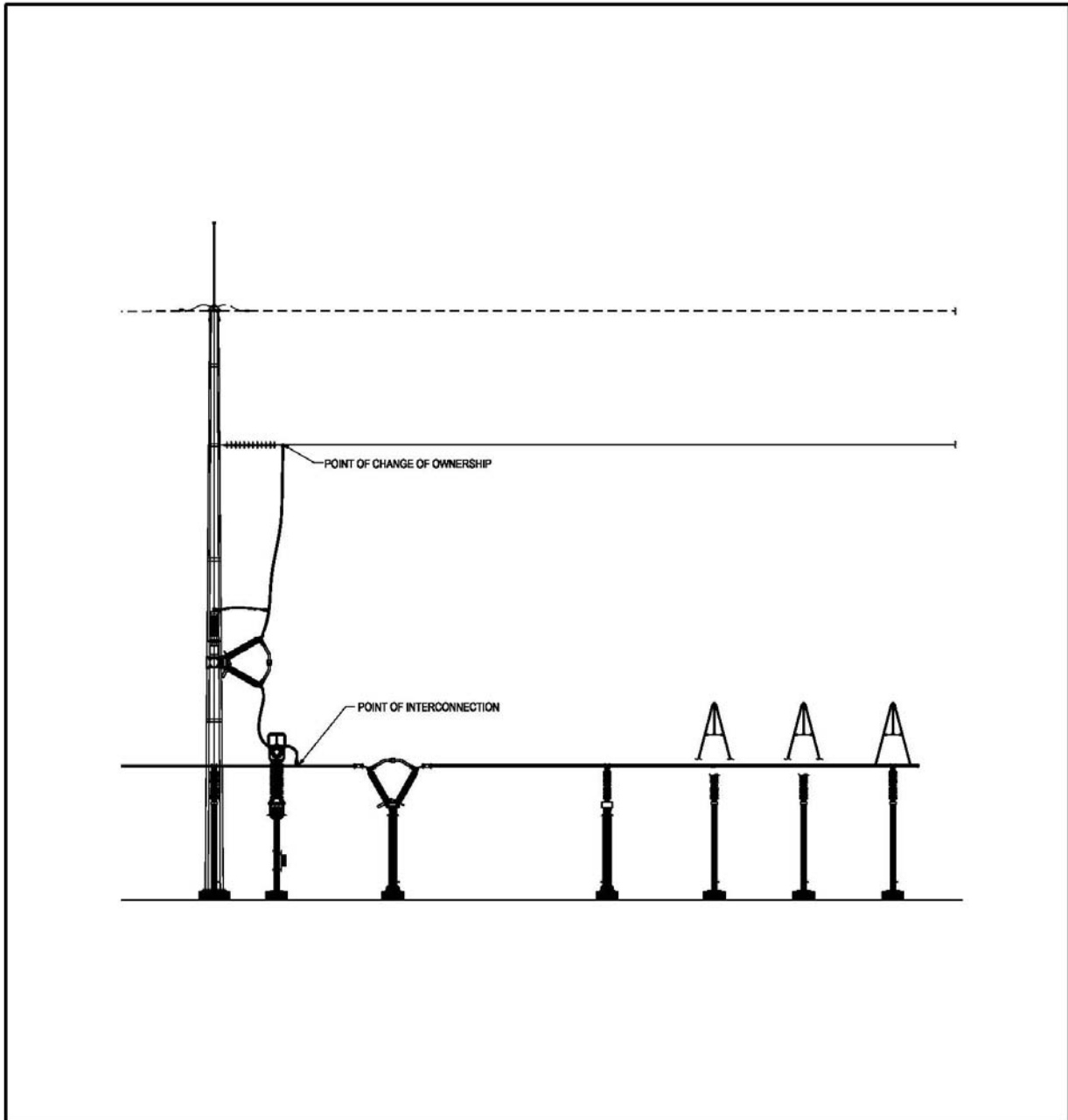

Figure A-3 Point of Interconnection & Change of Ownership Elevation (Typical)

DIAGRAMS ARE NOT FOR CONSTRUCTION PURPOSES



– END OF REPORT –



FACILITY STUDY

for

**IFS-2016-002-2 Network Upgrades
For
DISIS-2016-002-2**

New 275 Mvar Capacitor Bank at Border Substation
In Beckham County
Oklahoma

November 20, 2019

Adam Snapp, P.E.
Lead Engineer
Transmission Planning
OG&E Electric Services

Summary

Pursuant to the tariff and at the request of the Southwest Power Pool (SPP), Oklahoma Gas and Electric (OG&E) performed the following Facility Study for Network Upgrades to satisfy the Facility Study Agreement executed by the requesting customer for SPP DISIS-2016-002-2 for Network Upgrades. The request for interconnection was placed with SPP in accordance SPP's Open Access Transmission Tariff, which covers new generation interconnections on SPP's transmission system. The requirements for the Network Upgrade are to install 6-345kV switches, one 345kV breaker, one 345kV 275 Mvar capacitor bank consisting of 6 steps, and associated relay and control equipment in Border substation. The total cost for OKGE to complete these upgrades is \$5,929,000.

Table of Contents

| | |
|-------------------------------------|---|
| Table of Contents | 3 |
| Introduction | 4 |
| Interconnection Facilities | 5 |
| Interconnection Costs | 6 |
| One-Line diagram of Interconnection | 7 |

Introduction

The Southwest Power Pool has requested a Facility Study for Network Upgrades within the service territory of OG&E Electric Services (OKGE) in Beckham County Oklahoma. The proposed Network Upgrade Facilities are for the addition of a 345kV 275 Mvar capacitor bank at Border substation in Beckham county Oklahoma.

Network Constraints in the Southwest Public Service (SPS), OKGE and Western Farmers Electric Cooperative (WFEC) systems may be verified with a transmission service request and associated studies.

Other Network Constraints in the American Electric Power West (AEPW), Southwest Public Service (SPS), OKGE and Western Farmers Electric Cooperative (WFEC) systems may be verified with a transmission service request and associated studies.

Network Upgrade Facilities

The primary objective of this study is to identify network upgrades. The requirements for this Network Upgrade consist of installing a 345kV 275 Mvar capacitor bank at Border substation on the OG&E transmission system to accommodate generator interconnection requests identified in SPP-GI DISIS-2016-002-2. These 345kV network upgrades shall be constructed and maintained by OKGE.

The total cost for OKGE to install six 345kV switches, one 345kV 275 Mvar capacitor bank, one 345kV capacitor breaker, and associated relay and control equipment in Border substation is estimated at \$5,929,000.

This Facility Study does not guarantee the availability of transmission service necessary to deliver the additional generation to any specific point inside or outside the Southwest Power Pool (SPP) transmission system. The transmission network facilities may not be adequate to deliver the additional generation output to the transmission system. If the customer requests firm transmission service under the SPP Open Access Transmission Tariff at a future date, Network Upgrades or other new construction may be required to provide the service requested under the SPP OATT.

The costs of interconnecting the facility to the OKGE transmission system are listed in Table 1.

Short Circuit Fault Duty Evaluation

It is standard practice for OG&E to recommend replacing a circuit breaker when the current through the breaker for a fault exceeds 100% of its interrupting rating with re-closer de-rating applied, as determined by the ANSI/IEEE C37.5-1979, C37.010-1979 & C37.04-1979 breaker rating methods.

For this Network Upgrade, no breakers were found to exceed their interrupting capability after the addition of the 275 Mvar capacitor and related facilities. OG&E found no breakers that exceeded their interrupting capabilities on their system. Therefore, there is no short circuit upgrade costs associated with this DISIS-2016-002-2 Network Upgrade.

Table 1: Required Interconnection Network Upgrade Facilities

| Facility | ESTIMATED COST (2019 DOLLARS) |
|---|----------------------------------|
| OKGE – Network Upgrades Install 1-345kV 275 Mvar Capacitor Bank, 6-345kV Switches, 1-345kV Capacitor Breaker and associated relay and control equipment. | \$5,929,000. |
| Total | \$5,929,000. |

Prepared by:
Adam Snapp, P.E.
Lead Engineer, Transmission Planning
Email snappad@oge.com

November 20, 2019

Reviewed by:
Steve M Hardebeck PE, PMP
Manager- Transmission Planning
Phone 405-553-8225
Cell 405-317-0181
Email hardebsm@oge.com

Border Substation

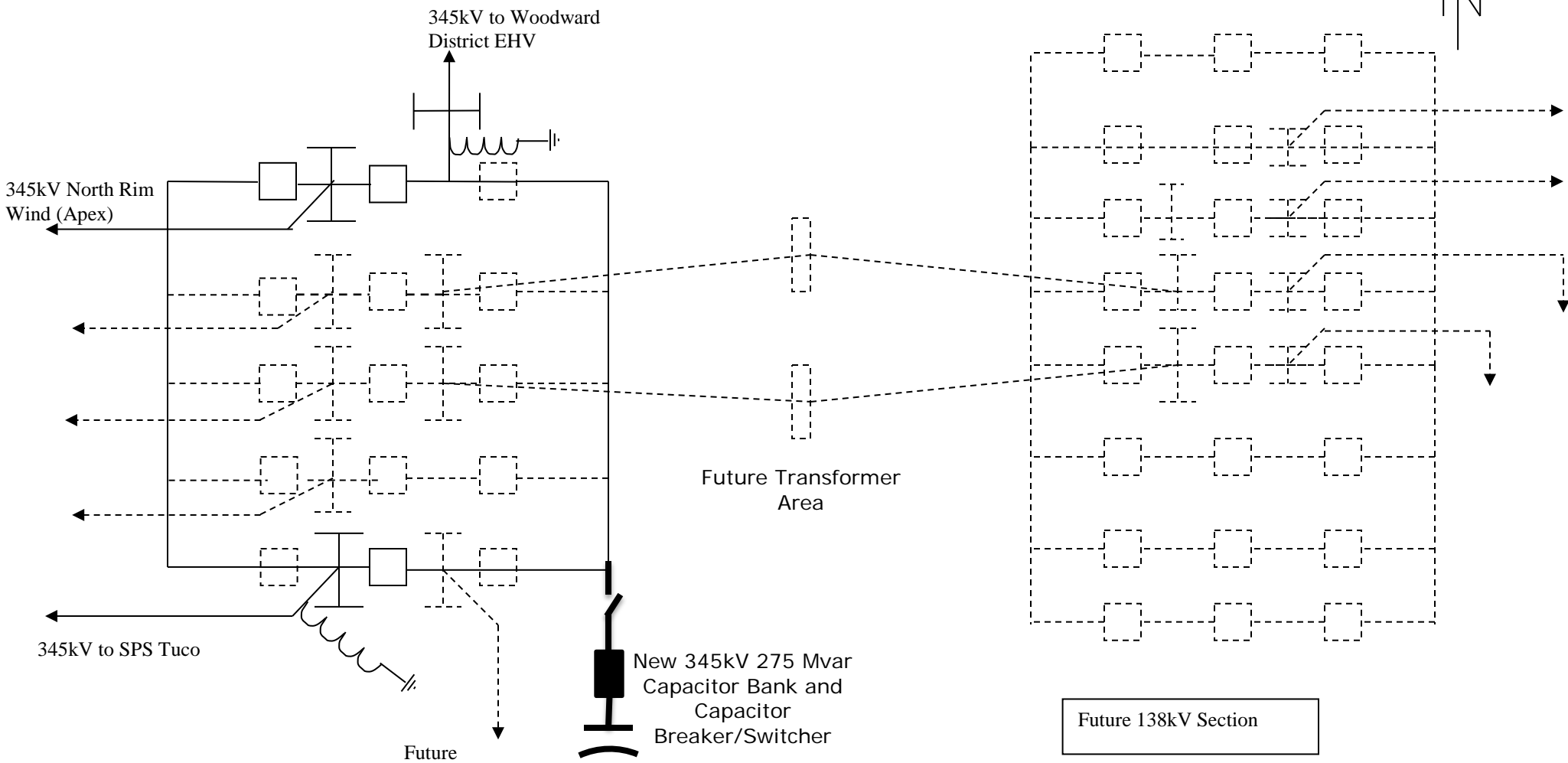
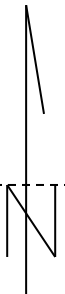

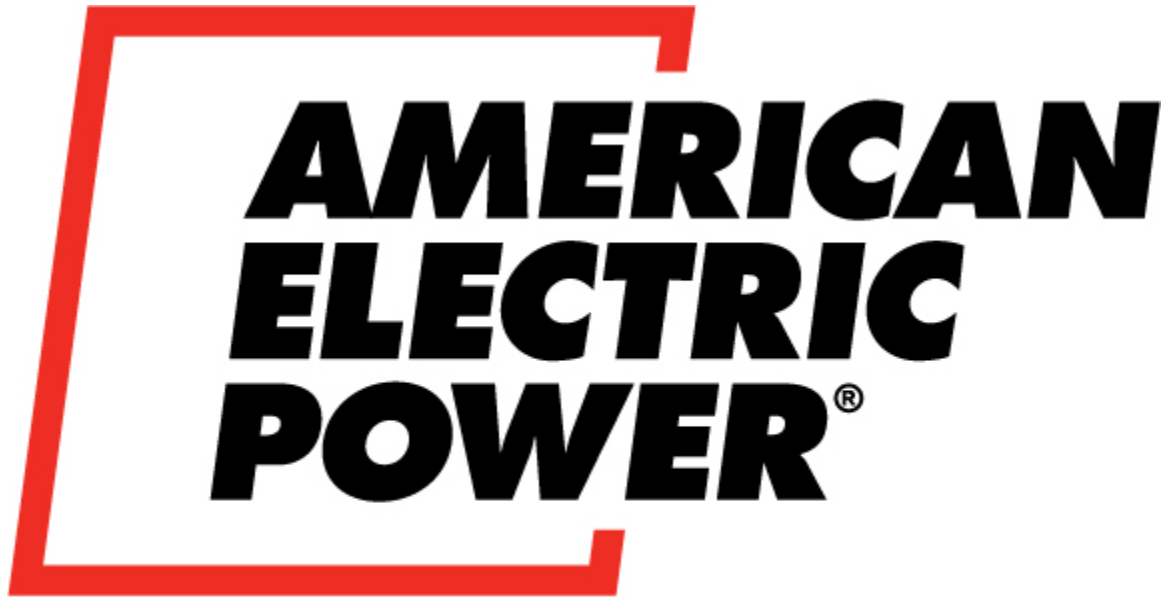

BOUNDLESS ENERGYSM

***Interconnection Facilities Study for
Oklaunion 345 kV Capacitor
Network Upgrade***

December 2019

Table of Contents

| | |
|---|---|
| Table of Contents | 2 |
| Summary | 3 |
| Interconnection Facilities | 4 |
| Interconnection Costs/Project Lead Time | 5 |
| One-line Diagram of Oklaunion Transmission Facility | 6 |

Summary

American Electric Power Southwest Transmission Planning (AEP) performed the following study at the request of the Southwest Power Pool (SPP) for SPP Generation Interconnection request DISIS-2016-002. Per the SPP Generator Interconnection Procedures (GIP), SPP requested that AEPW perform an Interconnection Facilities Studies (IFS) for Network Upgrade(s) in accordance with the Scope of Interconnection Facilities Study in GIP 8.10 and the Interconnection Facilities Study Procedures in accordance with GIP 8.13 for the following Network Upgrades:

- Oklaunion 345 kV
 - Install a minimum of + 200 MVAR of capacitor banks

Interconnection Facilities (See Figure 1)

Oklaunion 345 kV Substation

A new 345 kV, 200 MVAR minimum capacitor bank will be added at Oklaunion Station for the generation interconnection. This will consist of two 345 kV capacitor banks and associated breakers, microprocessor relays, circuit disconnects, and other associated equipment.

The design and construction of the new terminals will meet all AEP specifications for stations. Bus work and disconnect switches will be designed to accommodate the loading requirements, and circuit breakers will be rated to ensure adequate load and fault interrupting capability. AEP will own, operate and maintain the station.

Short Circuit Fault Duty Evaluation

It is standard practice for AEP to recommend replacing a circuit breaker when the current through the breaker for a fault exceeds 100% of its interrupting rating with recloser de-rating applied, as determined by the ANSI/IEEE C37.5-1979, C37.010-1979 & C37.04-1979 breaker rating methods.

In the AEP system, no breakers were found to exceed their interrupting capability after the addition of the generation and related facilities. Therefore, there are no short circuit upgrade costs associated with the GEN-2015-020 and 056 interconnections.

Interconnection Costs

Listed below are the associated costs.

| SYSTEM IMPROVEMENT | COST (2019 DOLLARS) |
|---|--------------------------------|
| Install a minimum of +200Mvar of Capacitor Bank(s) at Oklaunion 345 kV Including all metering, protection, and SCADA | \$9,453,182 |
| TRANSMISSION INTERCONNECTION FACILITY TOTAL COSTS | \$9,453,182 |

TABLE 1

Project Lead Time

Project in-service date is projected to be 24 months after the issuance of a NTC from the Southwest Power Pool.

(Stations Not Shown Completely)

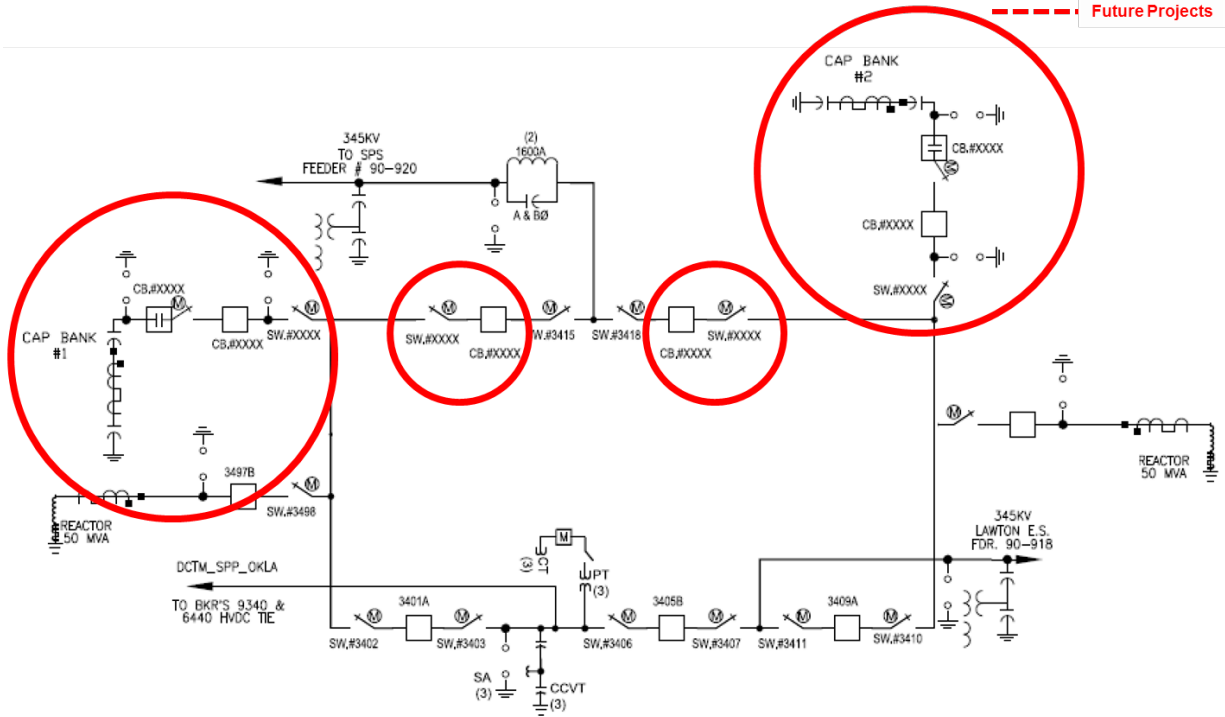

FIGURE 1



**Facility Study for Network Upgrades
as Requested by Southwest Power Pool (SPP)**

DISIS 2016-002-2

Group 6

Xcel Energy Services, Inc.
Transmission Planning South
Updated 12/18/2019

Executive Summary

The Southwest Power Pool (SPP or Transmission Provider) evaluated the generation facilities requesting to interconnect to the SPS transmission system in the Definitive Interconnection System Impact Study (DISIS-2016-002-2), which was completed in December 2019. The requests for interconnection were placed with SPP in accordance with SPP's Open Access Transmission Tariff (OATT).

To accommodate the Interconnection Customer's (IC) requests, SPP identified multiple network upgrades required as part of the DISIS study results. Southwestern Public Service Company (SPS or Transmission Owner) performed this Facility Study for the Network Upgrades to identify costs associated with the identified network upgrades. Below are the projects identified by SPP:

Upgrade Name

| |
|--|
| Crossroads - Tolk 345 kV Circuit #1 Rating Increase (956 MVA) |
| Crossroads - Eddy County 345 kV Circuit #1 Rating Increase (956 MVA) |
| Tolk 345/230 kV Transformer #2 |
| Deaf Smith - Plant X 230 kV Circuit #1 Rating Increase (430 MVA) |
| Newhart - Plant X 230 kV Circuit #1 Rating Increase (456 MVA) |
| Curry County- Deaf Smith 115 kV Circuit #1 Rebuild (90 MVA) |
| Tolk East - Tuco 230 kV Circuit #1 Rating Increase (478 MVA) |
| Crossroads 345 kV Capacitive Reactive Power Support (100 MVAR) |
| Tuco 230 kV Capacitive Reactive Power Support (100 MVAR) |
| Deaf Smith 115 kV Capacitive Reactive Power Support (100 MVAR) |
| Tolk West - Plant X 230 kV Circuit #1 Rating Increase (796 MVA)* |
| Tolk East - Plant X 230 kV Circuit #2 Rating Increase (796 MVA)* |

*Note: Rating increase identified by SPP DISIS Report is already being completed by SPS

General Description of Network Upgrades

The Objective of this study is to identify the network upgrades and the costs associated with them. Below is a high level description of the different projects and the scoping level costs¹ associated with each. All costs identified below are without escalation. All design and construction of the following projects will meet SPS standards and align with SPS standard equipment sizing. SPS will own, operate, and maintain all equipment identified in this report.

NOTE: All scopes, projects, schedules, and costs below are subject to change as detailed engineering moves forward. Outages, resource availability, federal and state approvals, etc. can impact the costs and schedules.

Crossroads - Tolk 345 kV Circuit 1 Rating Increase (956 MVA)

This existing line rating is currently limited by clearance issues. Approximately 2 structures will have to be replaced to increase the line rating to the required value.

Cost: \$184,650.00

Tentative Schedule: 12/2020

Crossroads - Eddy County 345 kV Circuit 1 Rating Increase (956 MVA)

This existing line rating is currently limited by clearance issues. Approximately 2 structures will have to be replaced to increase the line rating to the required value.

Cost: \$210,533.00

Tentative Schedule: 12/2020

Tolk 345/230 kV Transformer #2

The existing Tolk substation will have a 2nd 345/230 kV 560 MVA transformer installed. The existing 345 kV yard will be expanded to a ring bus configuration. The 345 kV line from Tolk to Crossroads will have to be re-terminated into a new position. Three breakers and 14 switches will be installed on the 345 kV portion and two breakers and four switches will be installed on the 230 kV portion. Relaying upgrades will be required at Crossroads.

Cost: \$14,055,360.00

Tentative Schedule: 3/2022

Deaf Smith - Plant X 230 kV Circuit 1 Rating Increase (430 MVA)

This existing line rating is currently limited by clearance issues. Approximately 100 structures will have to be replaced to increase the line rating to the required value.

Cost: \$4,578,401.00

Tentative Schedule: 12/2020

Newhart - Plant X 230 kV Circuit 1 Rating Increase (456 MVA)

This existing line rating is currently limited by clearance issues. Approximately 12 structures will have to be replaced to increase the line rating to the required value.

Cost: \$697,514.00

Tentative Schedule: 12/2020

Curry County - Deaf Smith 115 kV Circuit 1 Rebuild (90 MVA)

The existing conductor cannot meet the required rating identified by SPP so the line will be rebuilt in the existing corridor. The line is approximately 13 mile long, with 8.3 miles of the line double circuited with a 69 kV line.

Cost: \$4,852,215.00

Tentative Schedule: 12/2021

Tolk East - Tuco 230 kV Circuit 1 Rating Increase (478 MVA)

¹ The cost estimates are 2019 dollars with an accuracy level of ±20%.

This existing line rating is currently limited by clearance issues. Approximately 20 structures will have to be replaced to increase the line rating to the required value.

Cost: \$968,567.00

Tentative Schedule: 12/2020

Crossroads 345 kV Capacitive Reactive Power Support (100 MVAR)

The existing Crossroads substation ring bus will be expanded to a breaker and a half configuration and 4 new 345 kV breakers will be installed. There will be two switchable capacitor banks at 50 MVAR each. Each capacitor bank will have its own breaker. The substation footprint will be expanded to the east.

Cost: \$7,075,779.00

Tentative Schedule: 12/2020

Tuco 230 kV Capacitive Reactive Power Support (100 MVAR)

The existing Tuco substation breaker and a half configuration will be expanded to incorporate the proposed new 100 MVAR capacitor banks. Two new 230 kV breakers will be installed. There will be two switchable capacitor banks at 50 MVAR each. Each capacitor bank will have its own breaker. A pending EMTP study is still required to be run and the results may change the proposed scope.

Cost: \$5,943,138

Tentative Schedule: 6/2021

Deaf Smith 115 kV Capacitive Reactive Power Support (100 MVAR)

SPS has a planned project to rebuild the existing Deaf Smith 115 kV bus at a new location called Tierra Blanca substation. The capacitor banks identified by SPP will be installed at this new location. The Tierra Blanca substation will be built in a breaker and a half configuration. Current proposal is to install 3 x 40 MVAR capacitor banks. Four new 115 kV breakers and four new switches will be installed. A pending EMTP study is still required to be run and the results may change the proposed scope.

Cost: \$3,318,137.00

Tentative Schedule: 11/2021

Tolk West - Plant X 230 kV Circuit 1 Rating Increase (796 MVA)

This rating will be already met with an existing SPS project

Cost: \$0

Tentative Schedule: N/A

Tolk East - Plant X 230 kV Circuit 2 Rating Increase (796 MVA)

This rating will be already met with an existing SPS project

Cost: \$0

Tentative Schedule: N/A

– END OF REPORT –