



**INTERCONNECTION  
FACILITIES STUDY  
REPORT**

GEN-2015-067  
(IFS-2015-002-39)

Published March 2017

By SPP Generator Interconnections Dept.

## REVISION HISTORY

---

DATE OR VERSION NUMBER	AUTHOR	CHANGE DESCRIPTION	COMMENTS
3/15/2017	SPP	Initial draft report issued.	
3/16/2017	SPP	Initial draft report issued.	Correction to append GEN-2015-067 TO facility study report

DRAFT

# CONTENTS

---

Revision History.....	i
Summary.....	1
Introduction .....	1
Phase(s) of Interconnection Service .....	1
Credits/Compensation for Amounts Advanced for Network Upgrade(s).....	1
Interconnection Customer Interconnection Facilities .....	2
Transmission Owner Interconnection Facilities and Non-Shared Network Upgrade(s).....	2
Affected System Upgrade(s) .....	3
Shared Network Upgrade(s) .....	4
Other Network Upgrade(s) .....	4
Conclusion.....	5
Appendices.....	6
A: Transmission Owner’s Interconnection Facilities Study Report.....	7
B: Affected System Transmission Owner’s Affected System Interconnection Facilities Study Report	8

DRAFT

## SUMMARY

---

### *INTRODUCTION*

This Interconnection Facilities Study (IFS) for Interconnection Request GEN-2015-067/IFS-2015-002-39 is for a 150.30 MW generating facility located in Noble County, Oklahoma. The Interconnection Request was studied in the DISIS-2015-002 Impact Study for Energy Resource Interconnection Service (ERIS). The Interconnection Customer's requested in-service date is October 1, 2017.

The interconnecting Transmission Owner, Oklahoma Gas and Electric Company (OKGE), performed a detailed IFS at the request of SPP. The full report is included in Appendix A. Additionally, the Affected System Transmission Owner, Associated Electric Cooperative Inc. (AECI) has performing a detailed Affected System Interconnection Facilities Study (AS-IFS) for impacts on the AECI transmission system. The full report is included in Appendix B. SPP has determined that full Interconnection Service will be available after the assigned Transmission Owner Interconnection Facilities and Non-Shared Network Upgrades are completed.

The primary objective of the IFS is to identify necessary Transmission Owner Interconnection Facilities, Network Upgrade(s), other direct assigned upgrade(s), and associated upgrade lead times needed to grant the requested Interconnection Service at the specified Point of Interconnection (POI).

### *PHASE(S) OF INTERCONNECTION SERVICE*

It is not expected that Interconnection Service will occur in phases. However, Interconnection Service will not be available until all Interconnection Facilities and Network Upgrade(s) can be placed in service.

### *CREDITS/COMPENSATION FOR AMOUNTS ADVANCED FOR NETWORK UPGRADE(S)*

Interconnection Customer shall be entitled to compensation in accordance with Attachment Z2 of the SPP OATT for the cost of SPP Network Upgrades, including any tax gross-up or any other tax-related payments associated with the Network Upgrades, that are not otherwise refunded to the Interconnection Customer. Compensation shall be in the form of either revenue credits or incremental Long Term Congestion Rights (iLTCR).

### ***INTERCONNECTION CUSTOMER INTERCONNECTION FACILITIES***

The Generating Facility is proposed to consist of ninety (90) 1.667 MW Power Electronic Solar Ware inverters for a total generating nameplate capacity of 150.3 MW.

The Interconnection Customer's Interconnection Facilities to be designed, procured, constructed, installed, maintained, and owned by the Interconnection Customer at its sole expense include:

- A 34.5kV collector system;
- One (1) 138/34.5kV 99/132/165 MVA (ONAN/ONAF/ONAF) step-up transformer to be owned and maintained by the Interconnection Customer at the Interconnection Customer's substation;
- A one-and-a-half (1.5) mile overhead 138 kV line to connect the Interconnection Customer's substation to the POI at the 138 kV bus at the existing OKGE substation ("Sooner") that is owned and maintained by OKGE;
- All transmission facilities required to connect the Interconnection Customer's substation to the POI;
- Equipment at the Interconnection Customer's substation necessary to maintain a power factor at the POI between 95% lagging and 95% leading, including approximately 1.5Mvars<sup>1</sup> of reactors to compensate for injection of reactive power into the transmission system under no/reduced generating conditions. The Interconnection Customer may use wind turbine manufacturing options for providing reactive power under no/reduced generation conditions. The Interconnection Customer will be required to provide documentation and design specifications demonstrating how the requirements are met.

The Interconnection Customer shall coordinate relay, protection, control, and communication system configurations and schemes with the Transmission Owner.

### ***TRANSMISSION OWNER INTERCONNECTION FACILITIES AND NON-SHARED NETWORK UPGRADE(S)***

To facilitate interconnection, the interconnecting Transmission Owner will perform work as shown below necessary for the acceptance of the Interconnection Customer's Interconnection Facilities.

**Table 1** lists the Interconnection Customer's estimated cost responsibility for Transmission Owner Interconnection Facilities (TOIF) and Non-Shared Network Upgrade(s) and provides an estimated lead time for completion of construction. The estimated lead time begins when the Generator Interconnection Agreement has been fully executed.

---

<sup>1</sup> This approximate minimum reactor amount is needed for the current configuration of the wind farm as studied in the DISIS-2015-002 Impact Study.

Table 1: Interconnection Customer TOIF and Non-Shared Network Upgrade(s)

TOIF and Non-Shared Network Upgrades Description	Allocated Cost Estimate (\$)	Allocated Percent (%)	Total Cost Estimate (\$)	Estimated Lead Time
<b><u>OKGE Interconnection Substation: Transmission Owner Interconnection Facilities</u></b> 138kV Substation work for one (1) new line terminal, line switch, dead end structure, line relaying, communications, revenue metering, and line arrester. Transmission line work from PCO to POI.	\$2,361,000	100%	\$2,361,000	10 Months
<b><u>OKGE Interconnection Substation - Non-Shared Network Upgrades</u></b> Construct two (2) 2000A circuit breaker, control panel replacement, line relaying, disconnect switches, and associated material and equipment.	\$1,160,000	100%	\$1,160,000	
<b>Total</b>	<b>\$3,521,000</b>	<b>100%</b>	<b>\$3,521,000</b>	

***AFFECTED SYSTEM UPGRADE(S)***

To facilitate interconnection, the Affected System Transmission Owner, performed study work necessary for the acceptance of the Interconnection Customer’s Interconnection Facilities.

The Interconnection Customer’s costs for Affected System Upgrade(s) are estimated in **Table 2** below.

Table 2: Interconnection Customer Affected System Upgrades

Shared Network Upgrades Description	Allocated Cost Estimate (\$)	Allocated Percent (%)	Total Cost Estimate (\$)
<b><u>AECI Upgrades</u></b>	\$0	N/A	\$0
<b>Total</b>	<b>\$0</b>	<b>N/A</b>	<b>\$0</b>

**SHARED NETWORK UPGRADE(S)**

The Interconnection Customer’s share of costs for Shared Network Upgrades is estimated in **Table 3** below.

*Table 3: Interconnection Customer Shared Network Upgrades*

Shared Network Upgrades Description	Allocated Cost Estimate (\$)	Allocated Percent (%)	Total Cost Estimate (\$)
<u>Currently none</u>	\$0	N/A	\$0
<b>Total</b>	<b>\$0</b>	<b>N/A</b>	<b>\$0</b>

All studies have been conducted assuming that higher-queued Interconnection Request(s) and the associated Network Upgrade(s) will be placed into service. If higher-queued Interconnection Request(s) withdraw from the queue, suspend or terminate service, the Interconnection Customer’s share of costs may be revised. Restudies, conducted at the customer’s expense, will determine the Interconnection Customer’s revised allocation of Shared Network Upgrades.

**OTHER NETWORK UPGRADE(S)**

Certain Other Network Upgrades are currently not the cost responsibility of the Interconnection Customer but will be required for full Interconnection Service.

- 1) Currently None

Depending upon the status of higher- or equally-queued customers, the Interconnection Request’s in-service date is at risk of being delayed or Interconnection Service is at risk of being reduced until the in-service date of these Other Network Upgrades.

**CONCLUSION**

After all Interconnection Facilities, Network Upgrades, and Affected System Upgrade(s) have been placed into service, Interconnection Service for 150.30 MW can be granted. Interconnection Service will be delayed until the Transmission Owner Interconnection Facilities and Non-Shared Network Upgrades are completed. The Interconnection Customer’s estimated cost responsibility for Transmission Owner Interconnection Facilities, Non-Shared Network Upgrades is summarized in the table below.

*Table 4: Cost Summary*

<b>Description</b>	<b>Allocated Cost Estimate</b>
Transmission Owner Interconnection Facilities	\$2,361,000
Network Upgrades	\$1,160,000
Affected System Upgrades	\$0
<b>Total</b>	<b>\$3,521,000</b>

A draft Generator Interconnection Agreement will be provided to the Interconnection Customer consistent with the final results of this IFS report. The Transmission Owner and Interconnection Customer will have 60 days to negotiate the terms of the GIA consistent with the SPP OATT.

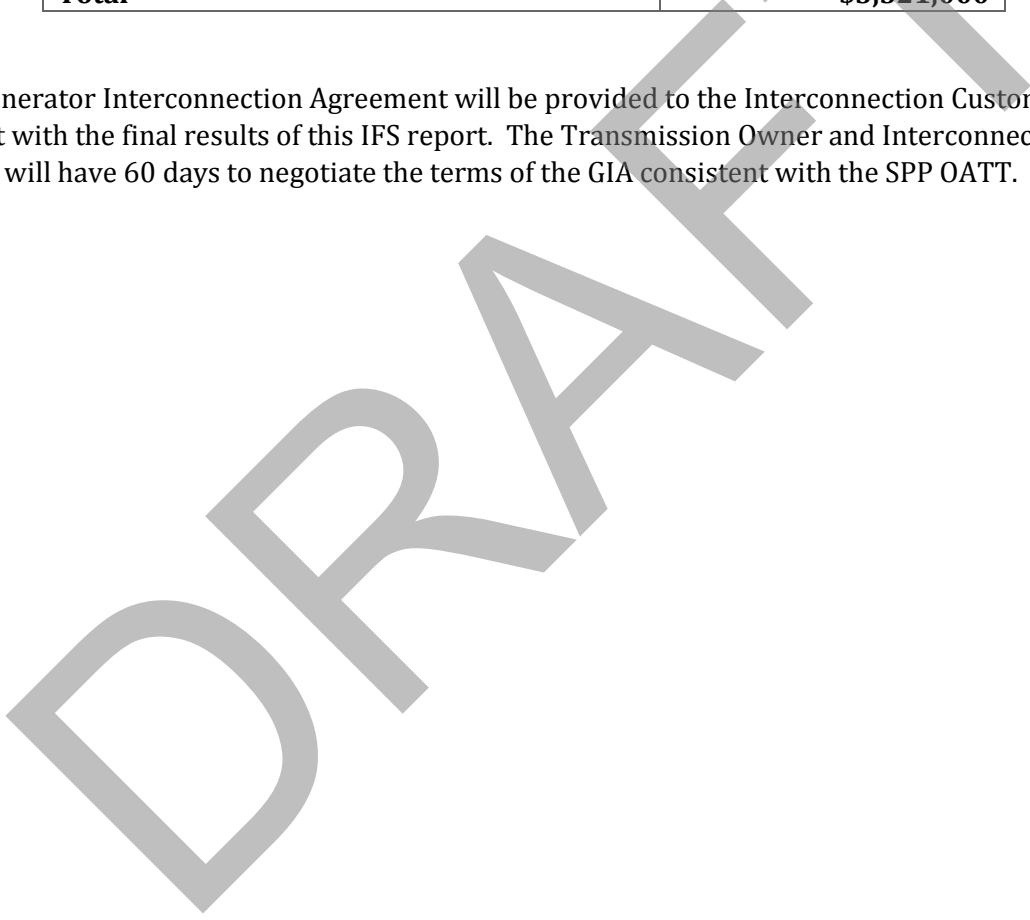



**APPENDICES**

---

DRAFT

# A: TRANSMISSION OWNER'S INTERCONNECTION FACILITIES STUDY REPORT

---

See next page for the Transmission Owner's Interconnection Facilities Study Report.

DRAFT



## **FACILITY STUDY**

**for**

### **Generation Interconnection Request 2015-067**

150 MW Wind Generating Facility  
In Noble County  
Oklahoma

January 19, 2016

Andrew R. Aston, PE  
Lead Engineer  
Transmission Planning  
**OG&E Electric Services**

## Summary

Pursuant to the tariff and at the request of the Southwest Power Pool (SPP), Oklahoma Gas and Electric (OG&E) performed the following Facility Study to satisfy the Facility Study Agreement executed by the requesting customer for SPP Generation Interconnection request Gen-2015-067. The request for interconnection was placed with SPP in accordance SPP's Open Access Transmission Tariff, which covers new generation interconnections on SPP's transmission system. The requirements for interconnection consist of adding two breakers, a line terminal, and a 138kV transmission line to the point of change of ownership with the generator lead outside of Power Plant property at Sooner 138kV substation. The total cost for OKGE to add two breakers, a terminal, and 138kV line in Sooner substation property, the interconnection facility, is estimated at \$3,521,000.

## Table of Contents

Table of Contents	3
Introduction	4
Interconnection Facilities	5
Interconnection Costs	6
One-Line diagram of Interconnection	7

DRAFT

## **Introduction**

The Southwest Power Pool has requested a Facility Study for the purpose of interconnecting a wind generating facility within the service territory of OG&E Electric Services (OKGE) in Noble County Oklahoma. The proposed 138kV point of interconnection is at Sooner 138kV Substation in Noble County Oklahoma. This substation is owned by OKGE.

The cost for adding a new 138kV terminal to the Substation, the required interconnection facility, is estimated at \$410,000.

Network Constraints in the Southwest Public Service (SPS), OKGE and Western Farmers Electric Cooperative (WFEC) systems may be verified with a transmission service request and associated studies.

## Interconnection Facilities

The primary objective of this study is to identify attachment facilities. The requirements for interconnection consist of adding a new 138kV terminal in Sooner Substation. This 138kV addition shall be constructed and maintained by OKGE. The Customer did not propose a route of its 138kV line to serve its 138kV facilities. It is assumed that obtaining all necessary right-of-way for the line into the new OKGE 138kV substation facilities will not be a significant expense.

The total cost for OKGE to add a new 138kV terminal in Sooner 138kV Substation, the interconnection facility, is estimated at \$410,000. This cost does not include building the 138kV line from the Customer substation to the point of the change of ownership outside of power plant property. The Customer is responsible for this 138kV line up to the point of change of ownership. This cost does not include the Customer's 138-34.5kV substation and the cost estimate should be determined by the Customer.

This Facility Study does not guarantee the availability of transmission service necessary to deliver the additional generation to any specific point inside or outside the Southwest Power Pool (SPP) transmission system. The transmission network facilities may not be adequate to deliver the additional generation output to the transmission system. If the customer requests firm transmission service under the SPP Open Access Transmission Tariff at a future date, Network Upgrades or other new construction may be required to provide the service requested under the SPP OATT.

The costs of interconnecting the facility to the OKGE transmission system are listed in Table 1.

Short Circuit Fault Duty Evaluation

It is standard practice for OG&E to recommend replacing a circuit breaker when the current through the breaker for a fault exceeds 100% of its interrupting rating with re-closer de-rating applied, as determined by the ANSI/IEEE C37.5-1979, C37.010-1979 & C37.04-1979 breaker rating methods.

For this generator interconnection, no breakers were found to exceed their interrupting capability after the addition of the Customer’s generation and related facilities. OG&E found no breakers that exceeded their interrupting capabilities on their system. Therefore, there is no short circuit upgrade costs associated with the Gen-2015-067 interconnection.

**Table 1: Required Interconnection Network Upgrade Facilities**

Facility	ESTIMATED COST (2016 DOLLARS)
OKGE – <b>Interconnection Facilities</b> - Add a single 138kV line terminal to an existing 138kV Substation. Dead end structure, line switch, line relaying, revenue metering including CTs and PTs	\$410,000
OKGE – <b>Transmission Line</b> - Build 138kV Transmission line to terminate generator lead outside of Power Plant property.	\$1,951,000
OKGE – <b>Network Upgrades</b> at an existing substation, Install 2-138kV 2000A breaker, line relaying, disconnect switches, and associated equipment	\$1,160,000
OKGE - Right-of-Way for 138kV terminal addition	No Additional ROW
<b>Total</b>	<b>\$3,521,000</b>

Prepared by Andrew R. Aston, P.E.  
Lead Engineer, Transmission Planning  
OG&E Electric Services

January 19, 2016

Reviewed by:  
*Steve M Hardebeck P. E.*  
Steve M. Hardebeck, P.E.  
Manager, Transmission Planning



# Sooner Substation

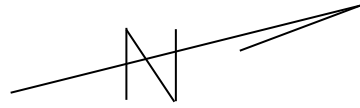
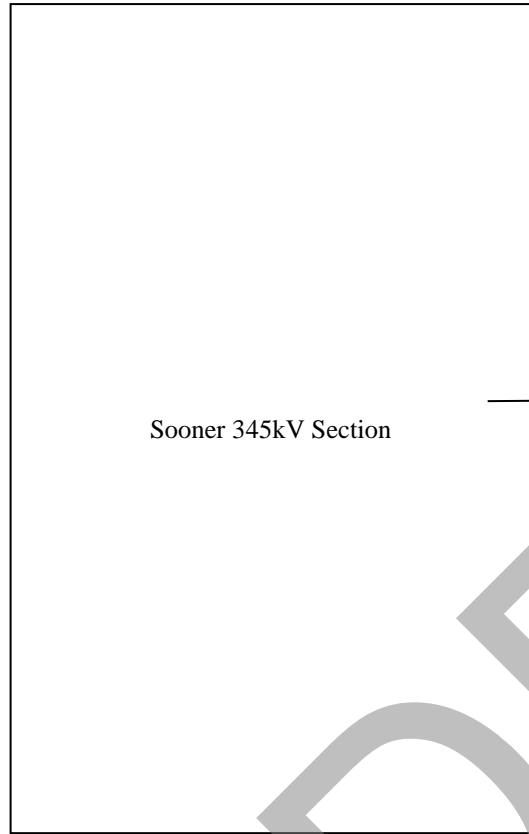

Point of Change of Ownership.  
OG&E to install and own Dead-  
End Structure

OG&E Property Line

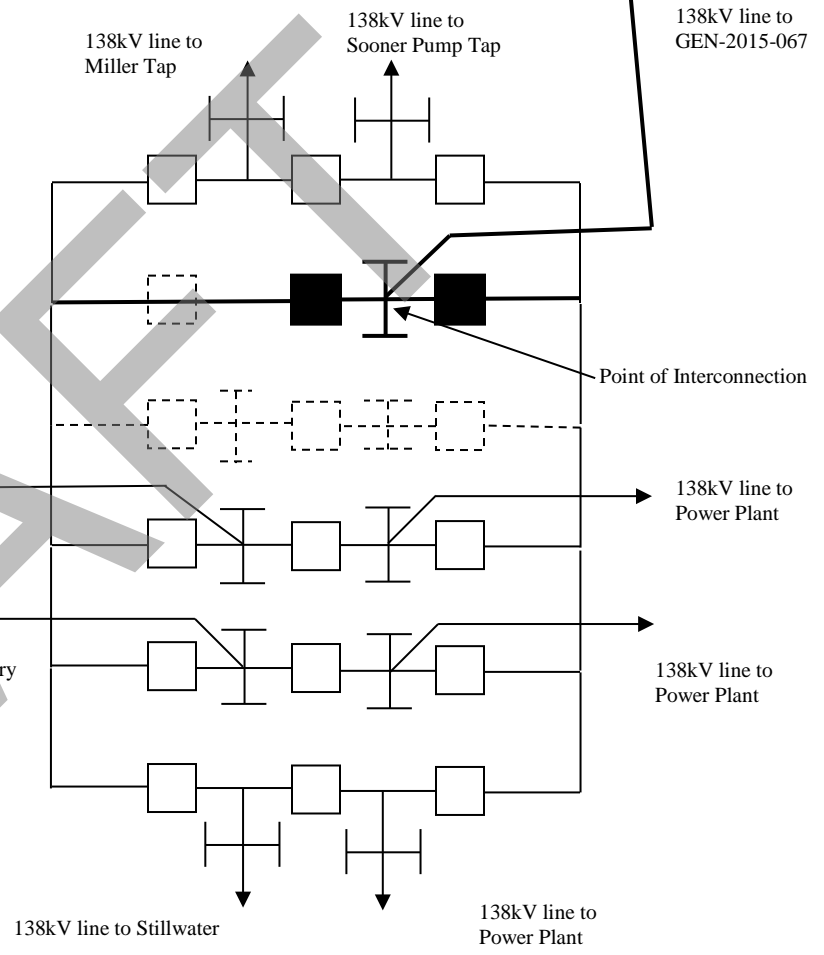

## **B: AFFECTED SYSTEM TRANSMISSION OWNER'S AFFECTED SYSTEM INTERCONNECTION FACILITIES STUDY REPORT**

---

See next page for the Affected System Transmission Owner's Affected System Interconnection Facilities Study Report.

DRAFT



Associated Electric Cooperative, Inc.

Your Touchstone Energy® Partner 

# Affected System Study

Omitted Text



December 2016

## Contents

---

Executive Summary .....	3
Introduction.....	4
System Representation.....	4
N-1 Results.....	7
N-1 Sensitivity Results .....	7
N-2 Results.....	8
Assessment.....	9

DRAFT

## Executive Summary

Associated Electric Cooperative, Inc. (AECI) was identified as a potentially Affected System in the Southwest Power Pool's (SPP) Definitive Interconnection System Impact Study for Generation Interconnection Requests (DISIS-2015-002) analysis of their GEN-2015-067 interconnection request. Omitted Text requested AECI perform an Affected System Study for the interconnection of 150 MW of solar generation at the Sooner 138 kV Substation.

The impact was evaluated against NERC Reliability Standard TPL-001-4 category P0, P1, and P6 events using AECI's Planning Criteria. The Affected System Study was a load flow analysis only. Stability and short circuit analysis have been performed by SPP and were not performed as part of the Affected System Study.

The interconnection request does not constitute a request for transmission service nor do the results of the Affected System Study confer upon Omitted Text any right to receive transmission service neither on the AECI transmission system nor on neighboring systems. All requests for transmission service must be requested in accordance with the AECI Open Access Transmission Tariff as well as in accordance with the rules of neighboring systems, if such request is made of them.

The results of the N-1 simulations show that the generators in the DISIS-2015-002 study cause the Cleveland-Silver City 138 kV line to overload for the loss of the Cleveland –North Tulsa 345 kV line. In the 2020 light load case the loading increases 39.0% from 80.4% to 119.4%.

The sensitivity results show the Omitted Text (GEN-2015-067) has a 4.6% impact on the Cleveland-Silver City 138 kV line loading.

Since the Omitted Text (GEN-2015-067) has less than a 5% impact (based upon the facility rating) on the overloaded facilities, the Project is not required to mitigate the overload.

**Introduction**

Associated Electric Cooperative, Inc. (AECI) was identified as a potentially Affected System in the Southwest Power Pool’s (SPP) Definitive Interconnection System Impact Study for Generation Interconnection Requests (DISIS-2015-002) analysis of their GEN-2015-067 interconnection request. **Omitted Text** requested AECI perform an Affected System Study for the interconnection of 150 MW of solar generation at the Sooner 138 kV Substation.

The objective of the affected system study is to confirm SPP’s study and evaluate the impact of the addition of solar generation at the Sooner 138 kV substation upon AECI’s transmission system, develop solutions/system improvements with cost estimates, and determine a schedule for completing the improvements.

The impact was evaluated against NERC Reliability Standard TPL-001-4 category P0, P1, and P6 events using AECI’s Planning Criteria. The Affected System Study was a load flow analysis only. Stability and short circuit analysis have been performed by SPP and were not performed as part of the Affected System Study.

**System Representation**

The base models used for the Affected System Study were models SPP developed for the July 8, 2016 DISIS-2015-002 generation interconnection requests as shown in Table 1.

**Table 1 Models**

<u>Year</u>	<u>Season</u>	<u>Base Case</u>	<u>Generation Case</u>
2016	Winter	BC0016WP0-C	TC0016WP0-C
2016	Winter	BC00NR16WP0-C	TC00NR16WP0-C
2016	Winter	BC08ALL16WP0-C	TC08ALL16WP0-C
2017	Summer	BC0017SP0-C	TC0017SP0-C
2017	Spring	BC08ALL17G0-C	TC08ALL17G0-C
2017	Spring	BC08NR17G0-C	TC08NR17G0-C
2020	Summer	BC0020SP0-C	TC0020SP0-C
2020	Winter	BC0020WP0-C	TC0020WP0-C
2020	Summer	BC00NR20SP0-C	TC00NR20SP0-C
2020	Winter	BC00NR20WP0-C	TC00NR20WP0-C
2020	Light Load	BC08NR20L0-C	TC08NR20L0-C
2020	Light Load	BC08ALL20L0-C	TC08ALL20L0-C
2020	Summer	BC08ALL20SP0-C	TC08ALL20SP0-C
2020	Winter	BC08ALL20WP0-C	TC08ALL20WP0-C
2025	Summer	BC0025SP0-C	TC0025SP0-C
2025	Summer	BC00NR25SP0-C	TC00NR25SP0-C
2025	Summer	BC08ALL25SP0-C	TC08ALL25SP0-C

These models were checked against AECI models to identify any needed topology changes and updated as appropriate.

Figure 1 below shows a one-line of the Proposed Point of Interconnection for GEN-2015-067.

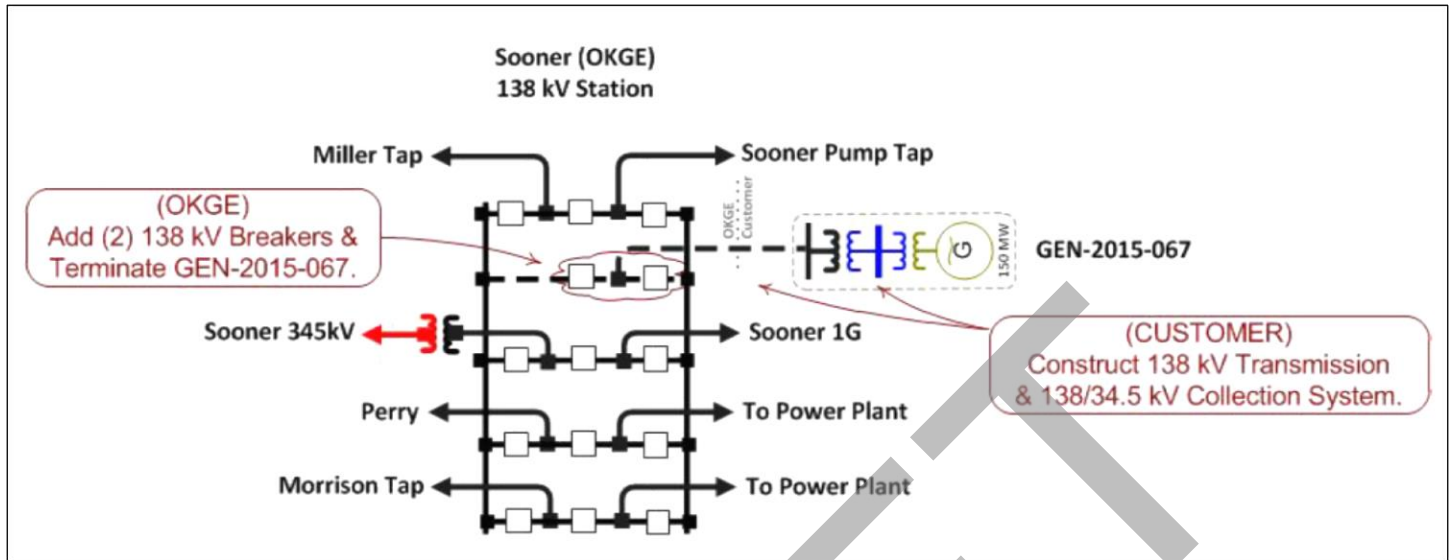

Figure 1: GEN-2015-067 Proposed Point of Interconnection

### System Analysis Methodology

Normal conditions and Contingency analysis were simulated on the July 8, 2016 updated DISIS-2015-002 SPP models.

- Normal conditions (TPL-001-4 P0)
- All N-1 single-element contingencies 69 kV and above in the following areas were simulated (TPL-001-4 P2):
  - AREA 330 /\*AECI
  - AREA 333 /\*City of Columbia
  - AREA 523 /\*GRDA
  - AREA 347 /\*TVA
  - AREA 327 /\*EES-ARK
  - AREA 351 /\*EES
  - AREA 356 /\*AMMO
  - AREA 515 /\*SWPA
  - AREA 520 /\*AEPW
  - AREA 524 /\*OKGE
  - AREA 525 /\*WFEC
  - AREA 536 /\*WERE
  - AREA 540 /\*MIPU
  - AREA 541 /\*KACP
  - AREA 544 /\*EMDE
  - AREA 545 /\*INDN
  - AREA 546 /\*SPRM
  - AREA 627 /\*ALTW
  - AREA 635 /\*MEC
  - AREA 640 /\*NPPD
  - AREA 645 /\*OPPD
  - AREA 650 /\*LES
  - AREA 652 /\*WAPA

- Select N-2 Contingencies 69 kV and above in the project area were evaluated (TPL-001-4 P6).

#### Monitoring of Facilities

- AECI monitored all AECI 69 kV and above facilities for criteria violations
- AECI developed corrective plans for all N-1 violations identified.

#### Sensitivity

If criteria violations were observed, then GEN-2015-067 was removed from service, and the problem contingencies were simulated again to determine the impact of the generator.

The generator was deemed to have a negative impact on a facility if it caused more than a 5% impact on a post-project criteria violation that was not already a pre-project violation (based upon the impacted facility's rating).

DRAFT



**N-1 Results**

The N-1 simulation results as shown in Table 1 below shows DISIS-2015-002 Projects' impacts to the Cleveland-Silver City 138 kV line.

**Table 2: Impacts of All DISIS-2015-002 Projects**

CASE	ELEMENT	CONTINGENCY	MVA RATING	Pre-Projects		Post-Projects		% Delta
				MVA Flow	% Load	MVA Flow	% Load	
<b>2020 Light Load 08ALL</b>	Cleveland-Silver City 138kV Ckt 1 Line Loading	Cleveland-T.NO.--7 345kV Ckt #1 Out	174	145	80.4%	213.5	119.4%	39.0%

**N-1 Sensitivity Results**

GEN-2015-067, was turned off and the contingencies in Table 2 were simulated again to determine the impacts attributable to GEN-2015-067. Table 3 below shows the impacts with GEN-2015-067 turned off. The results indicate that GEN-2015-067 has a less than 5% impact on the overloaded Cleveland-Silver City 138kV Ckt 1 line (2020LL).

**Table 3: Sensitivity Results of Gen-067 Impacts**

CASE	ELEMENT	CONTINGENCY	Pre-Projects % Load	Post-Projects % Load	Post-Projects without Gen-067 % Load	% Delta (Gen-067 Impact)
<b>2020 Light Load 08ALL</b>	Cleveland-Silver City 138kV Ckt 1 Line Loading	Cleveland-T.NO.--7 345kV Ckt #1 Out	80.4%	<b>119.4%</b>	<b>114.8%</b>	<b>4.6%</b>

**N-2 Results**

For informational purposes, select N-2 (TPL-001-4 P6) contingencies were simulated. Table 4 below shows the results of those simulations.

**Table 4: Impacts of All DISIS-2015-002 Projects for N-2 Contingencies**

CASE	ELEMENT	CONTINGENCY	MVA RATING	Pre-Project		Post-Project		% Delta
				MVA Flow	% Load	MVA Flow	% Load	
<b>2017 Spring 08ALL</b>	Cleveland-Silver City 138kV Ckt 1 Line Loading	Cleveland-T.NO.--7 345kV & Sooner-SpringCreek Out	174	124.4	71.5%	208.4	<b>119.8%</b>	48.3%
<b>2020 Light Load 08ALL</b>	Cleveland-Silver City 138kV Ckt 1 Line Loading	Cleveland-T.NO.--7 345kV & Cleveland 161/69kV Xfmr#1 Out	174	141.6	81.4%	210.0	<b>120.7%</b>	39.3%
	Cleveland-Silver City 138kV Ckt 1 Line Loading	Cleveland-T.NO.--7 345kV & Cleveland 161/69kV Xfmr#1 Out	174	167.8	96.4%	249.3	<b>143.3%</b>	46.8%
<b>2020 Summer 08ALL</b>	Cleveland-Dist.-Osage 69kV Ckt 1 Line Loading	Cleveland-T.NO.--7 345kV & Cleveland-SilverCity 138kV Out	44	38.9	88.5%	50.1	<b>113.9%</b>	25.4%
	Cleveland-Osage 69kV Ckt 1 Line Loading	Cleveland-T.NO.--7 345kV & Cleveland-SilverCity 138kV Out	87	67.0	77.0%	87.7	<b>100.9%</b>	23.9%
	Cleveland-Silver City 138kV Ckt 1 Line Loading	Cleveland-T.NO.--7 345kV & Sooner-SpringCreek Out	174	119.6	68.7%	197.4	<b>113.5%</b>	44.7%
	Cleveland 138/69kV Xfmr #2 Loading	Cleveland-T.NO.--7 345kV & Cleveland 161/69kV Xfmr#1 Out	494	455.8	92.3%	571.3	<b>115.7%</b>	23.4%
<b>2025 Summer 08ALL</b>	Cleveland-Dist.-Osage 69kV Ckt 1 Line Loading	Cleveland-T.NO.--7 345kV & Cleveland-SilverCity 138kV Out	44	34.4	78.2%	45.6	<b>103.7%</b>	25.5%
	Cleveland-Silver City 138kV Ckt 1 Line Loading	Cleveland-T.NO.--7 345kV & Sooner-SpringCreek Out	174	99.8	57.4%	176.5	<b>101.4%</b>	44.1%
	Cleveland 138/69kV Xfmr #2 Loading	Cleveland-T.NO.--7 345kV & Cleveland 161/69kV Xfmr#1 Out	494	407.2	82.4%	519.0	<b>105.1%</b>	22.6%

## Assessment

The results of the N-1 simulations show that the generators in the DISIS-2015-002 study cause the Cleveland-Silver City 138 kV line to overload for the loss of the Cleveland –North Tulsa 345 kV line. In the 2020 light load case the loading increases 39.0% from 80.4% to 119.4%.

The sensitivity results show the Omitted Text (GEN-2015-067) has a 4.6% impact on the Cleveland-Silver City 138 kV line loading.

Since the Omitted Text (GEN-2015-067) has less than a 5% impact (based upon the facility rating) on the overloaded facilities, the Project is not required to mitigate the overload.

The interconnection request does not constitute a request for transmission service nor do the results of the Affected System Study confer upon Omitted Text any right to receive transmission service neither on the AECI transmission system nor on neighboring systems. All requests for transmission service must be requested in accordance with the AECI Open Access Transmission Tariff as well as in accordance with the rules of neighboring systems, if such request is made of them.

DRAFT