



INTERCONNECTION FACILITIES STUDY REPORT

GEN-2015-061
(IFS-2015-002-14)

Published April 2017

By SPP Generator Interconnections Dept.

REVISION HISTORY

DATE OR VERSION NUMBER	AUTHOR	CHANGE DESCRIPTION	COMMENTS
3/15/2017	SPP	Initial draft report issued.	
3/20/2017	SPP	Draft report issued.	Included additional costs if DISIS-2015-002 requests require only one terminal at Mingo 345kV.
4/18/2017	SPP	Final Interconnection Facilities Study Report Issued	

CONTENTS

Revision History.....	i
Summary.....	1
Introduction	1
Phase(s) of Interconnection Service	1
Credits/Compensation for Amounts Advanced for Network Upgrade(s).....	1
Interconnection Customer Interconnection Facilities	2
Transmission Owner Interconnection Facilities and Non-Shared Network Upgrade(s).....	2
Shared Network Upgrade(s)	3
Other Network Upgrade(s)	4
Conclusion.....	4
Appendices.....	5
A: Transmission Owner’s Interconnection Facilities Study Report.....	6

SUMMARY

INTRODUCTION

This Interconnection Facilities Study (IFS) for Interconnection Request GEN-2015-061/IFS-2015-002-14 is for a 200.00 MW generating facility located in Logan and Thomas Counties, Kansas. The Interconnection Request was studied in the DISIS-2015-002 Impact Study for Energy Resource Interconnection Service (ERIS) and Network Resource Interconnection Service (NRIS). Prior to an executed IFS agreement, the Interconnection Customer requested to withdraw NRIS per Section 4.4.1 of the Southwest Power Pool (SPP) Generator Interconnection Procedures (GIP), therefore ERIS-only was analyzed for this request in the DISIS-2015-002-1 Impact Restudy and DISIS-2015-002-2 Impact Restudy. The Interconnection Customer's requested in-service date is December 31, 2018.

The interconnecting Transmission Owner, Sunflower Electric Power Corporation (SUNC), performed a detailed IFS at the request of SPP. The full report is included in Appendix A. SPP has determined that full Interconnection Service will be available after the assigned Transmission Owner Interconnection Facilities and Shared Network Upgrades are completed.

The primary objective of the IFS is to identify necessary Transmission Owner Interconnection Facilities, Network Upgrade(s), other direct assigned upgrade(s), and associated upgrade lead times needed to grant the requested Interconnection Service at the specified Point of Interconnection (POI).

PHASE(S) OF INTERCONNECTION SERVICE

It is not expected that Interconnection Service will occur in phases. However, Interconnection Service will not be available until all Interconnection Facilities and Network Upgrade(s) can be placed in service.

CREDITS/COMPENSATION FOR AMOUNTS ADVANCED FOR NETWORK UPGRADE(S)

Interconnection Customer shall be entitled to compensation in accordance with Attachment Z2 of the SPP OATT for the cost of SPP Network Upgrades, including any tax gross-up or any other tax-related payments associated with the Network Upgrades, that are not otherwise refunded to the Interconnection Customer. Compensation shall be in the form of either revenue credits or incremental Long Term Congestion Rights (iLTCR).

INTERCONNECTION CUSTOMER INTERCONNECTION FACILITIES

The Generating Facility is proposed to consist of one-hundred (100) 2.0 MW General Electric (G.E.) wind generators for a total generating nameplate capacity of 200.00 MW.

The Interconnection Customer's Interconnection Facilities to be designed, procured, constructed, installed, maintained, and owned by the Interconnection Customer at its sole expense include:

- A 34.5kV collector system;
- Two (2) 345/34.5kV 66/88/110 MVA (ONAN/ONAF/ONAF) step-up transformer to be owned and maintained by the Interconnection Customer at the Interconnection Customer's substation;
- A twelve (12) mile overhead 345kV line to connect the Interconnection Customer's substation to the POI at the 345kV bus at the existing SUNC substation ("Mingo") that is owned and maintained by SUNC;
- All transmission facilities required to connect the Interconnection Customer's substation to the POI;
- Equipment at the Interconnection Customer's substation necessary to maintain a power factor at the POI between 95% lagging and 95% leading, including approximately 26.3Mvars¹ of reactors to compensate for injection of reactive power into the transmission system under no/reduced generating conditions. The Interconnection Customer may use wind turbine manufacturing options for providing reactive power under no/reduced generation conditions. The Interconnection Customer will be required to provide documentation and design specifications demonstrating how the requirements are met.

The Interconnection Customer shall coordinate relay, protection, control, and communication system configurations and schemes with the Transmission Owner.

TRANSMISSION OWNER INTERCONNECTION FACILITIES AND NON-SHARED NETWORK UPGRADE(S)

To facilitate interconnection, the interconnecting Transmission Owner will perform work as shown below necessary for the acceptance of the Interconnection Customer's Interconnection Facilities.

Table 1 lists the Interconnection Customer's estimated cost responsibility for Transmission Owner Interconnection Facilities (TOIF) and Non-Shared Network Upgrade(s) and provides an estimated lead time for completion of construction. The estimated lead time begins when the Generator Interconnection Agreement has been fully executed.

GEN-2015-061/IFS-2015-002-14 and GEN-2015-065/IFS-2015-002-14 are equally queued requests and requested POI at the same bus, Mingo 345kV. As a result the POI Network Upgrades costs for both POI positions totaling to \$13,997,972 is divided equally between the two requests as displayed in **Table 2**. If GEN-2015-061/IFS-2015-002-14 or GEN-2015-065/IFS-2015-002-14 withdraw from the queue, suspend, or terminate service, the Interconnection Customer's share of costs may be revised for expansion of Mingo 345kV to accommodate one new line terminal along with four (4) new breakers currently estimated at \$10,248,063

¹ This approximate minimum reactor amount is needed for the current configuration of the wind farm as studied in the DISIS-2015-002 Impact Study.

Table 1: Interconnection Customer TOIF and Non-Shared Network Upgrade(s)

TOIF and Non-Shared Network Upgrades Description	Allocated Cost Estimate (\$)	Allocated Percent (%)	Total Cost Estimate (\$)	Estimated Lead Time
<u>SUNC Mingo Interconnection Substation: Transmission Owner Interconnection Facilities</u> Construct two (2) 345 kV line terminals, line switches, dead end structure, line relaying, communications, revenue metering, line arrester and all associated equipment and facilities necessary to accept transmission line from Interconnection Customer’s Generating Facility.	\$2,046,000	50.00	\$4,092,000	24Months
Total	\$2,046,000	50.00	\$4,092,000	

SHARED NETWORK UPGRADE(S)

The Interconnection Customer’s share of costs for Shared Network Upgrades is estimated in **Table 2** below.

Table 2: Interconnection Customer Shared Network Upgrades

Shared Network Upgrades Description	Allocated Cost Estimate (\$)	Allocated Percent (%)	Total Cost Estimate (\$)	
<u>SUNC Mingo Interconnection Substation - Shared Network Upgrades</u> Construct five (5) 345kV 3000 continuous ampacity breakers, control panels, line relaying, disconnect switches, structures, foundations, conductors, insulators, and all other associated work and materials.	\$4,942,986	50.00	\$9,885,972	24Months
Total	\$4,942,986	50.00	\$9,885,972	

All studies have been conducted assuming that higher-queued Interconnection Request(s) and the associated Network Upgrade(s) will be placed into service. If higher-queued Interconnection Request(s) withdraw from the queue, suspend or terminate service, the Interconnection Customer’s share of costs may be revised. Restudies, conducted at the customer’s expense, will determine the Interconnection Customer’s revised allocation of Shared Network Upgrades.

OTHER NETWORK UPGRADE(S)

Certain Other Network Upgrades are currently not the cost responsibility of the Interconnection Customer but will be required for full Interconnection Service.

- 1) Currently None

Depending upon the status of higher- or equally-queued customers, the Interconnection Request’s in-service date is at risk of being delayed or Interconnection Service is at risk of being reduced until the in-service date of these Other Network Upgrades.

CONCLUSION

After all Interconnection Facilities and Network Upgrades have been placed into service, Interconnection Service for 200.00 MW can be granted. Interconnection Service will be delayed until the Transmission Owner Interconnection Facilities and Shared Network Upgrades are completed. The Interconnection Customer’s estimated cost responsibility for Transmission Owner Interconnection Facilities, Non-Shared Network Upgrades is summarized in the table below.

Table 3: Cost Summary

Description	Allocated Cost Estimate
Transmission Owner Interconnection Facilities	\$2,046,000
Network Upgrades	\$4,942,986
Total	\$6,988,986

A draft Generator Interconnection Agreement will be provided to the Interconnection Customer consistent with the final results of this IFS report. The Transmission Owner and Interconnection Customer will have 60 days to negotiate the terms of the GIA consistent with the SPP Open Access Transmission Tariff (OATT).

APPENDICES

A: TRANSMISSION OWNER'S INTERCONNECTION FACILITIES STUDY REPORT

See next page for the Transmission Owner's Interconnection Facilities Study Report.

1. Introduction

<OMITTED TEXT> (Interconnection Customer) has requested an Interconnection Facilities Study under the Southwest Power Pool Open Access Transmission Tariff (OATT) for interconnecting a 200.00 MW wind generation facility in Logan and Thomas Counties, Kansas to the transmission system of Sunflower Electric Power Corporation (SUNC). The generator facility, GEN-2015-061, is comprised of one-hundred (100) 2.0 MW General Electric (G.E.) wind generators for a total generating nameplate capacity of 200.00 MW.

2. Transmission Owner Interconnection Facilities and Shared Network Upgrades

The cost for the Transmission Owner Interconnection Facilities and Shared Network Upgrades is listed below in **Table 1**. GEN-2015-061/IFS-2015-002-14 is planned to interconnect at the SUNC owned 345kV bus located at Mingo Substation. The estimated lead time for Transmission Owner Interconnection Facilities and Network Upgrades is twenty-four (24) months after a fully executed Generator Interconnection Agreement (GIA). The one-line diagram is shown in **Figure 1**.

GEN-2015-061/IFS-2015-002-14 and GEN-2016-065/IFS-2015-002-14 are equally queued requests and requested POI at the same bus, Mingo 345kV. As a result the costs for both POI positions totaling to \$13,997,972 is divided equally between the two requests. If GEN-2015-061/IFS-2015-002-14 or GEN-2016-065/IFS-2015-002-14 withdraw from the queue, suspend, or terminate service, the Interconnection Customer’s share of costs may be revised.

Table 1: Required Transmission Owner Interconnection Facilities and Non Shared Network Upgrades

Description	Allocated Cost	Total Project Cost
<p><u>SUNC Mingo Interconnection Substation: Transmission Owner Interconnection Facilities</u> Construct one (1) 345 kV line terminal, line switches, dead end structure, line relaying, communications, revenue metering, line arrestor and all associated equipment and facilities necessary to accept transmission line from Interconnection Customer’s Generating Facility.</p>	\$2,046,000	\$4,092,000
<p><u>SUNC Mingo Interconnection Substation - Shared Network Upgrades</u> Construct five (5) 345kV 3000 continuous ampacity breakers, control panel replacements, line relaying, disconnect switches, structures, foundations, conductors, insulators, and all other associated work and materials.</p>	\$4,942,986	\$9,885,972
Total:	\$6,988,986	\$13,977,972

Figure 1: Interconnection Configuration for GEN-2015-061

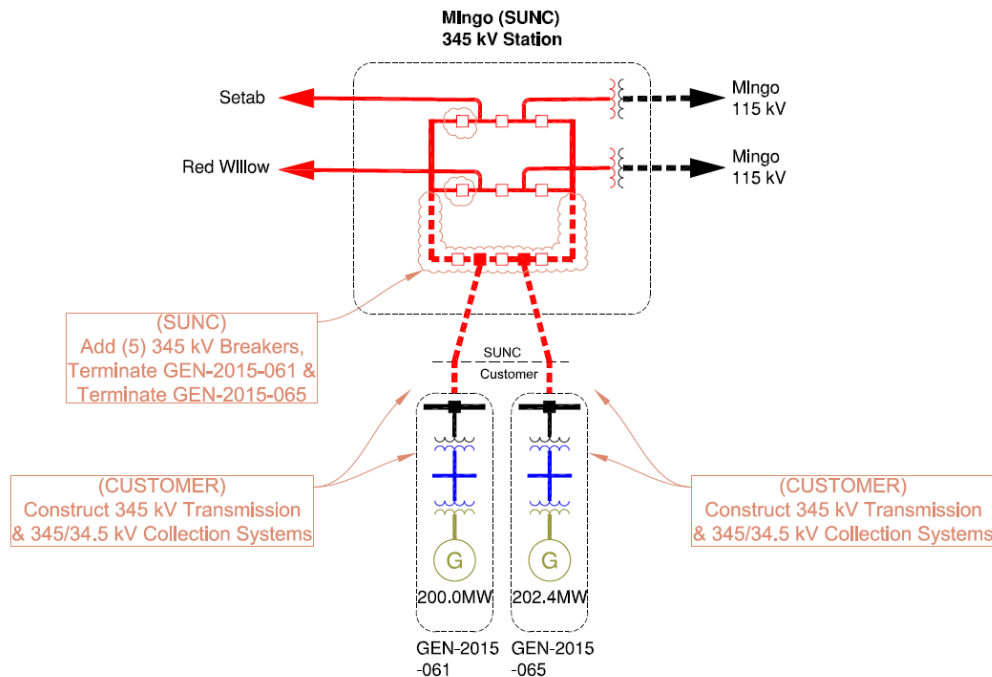

2.1. Interconnection Customer Facilities – The Interconnection Customer will be responsible for its Generating Facility and its one (1) 345/34.5 kV transformer that connect to the wind generators to the Point of Interconnection. In addition, the Interconnection Customer will be required to install the following equipment in its facilities.

2.1.1. Reactive Power Equipment – The Customer will be responsible for reactive power compensation equipment to maintain 95% lagging (providing vars) and 95% leading (absorbing vars) power factor at the POI, which may be provided in part by the reactive power capability of the generators. Any capacitor banks installed by the Interconnection Customer shall not cause voltage distortion in accordance with Article 9.7.4 of the standard SPP Generator Interconnection Agreement.

3. Conclusion

The Interconnection Customer’s Interconnection Facilities and Non-Shared Network Upgrades are estimated at \$6,988,986.