



**INTERCONNECTION
FACILITIES STUDY
REPORT**

GEN-2015-056
(IFS-2015-002-40)

Published November 2018

By SPP Generator Interconnections Dept.

REVISION HISTORY

DATE OR VERSION NUMBER	AUTHOR	CHANGE DESCRIPTION
4/05/2017	SPP	Initial draft report issued.
6/29/2018	SPP	Revised draft report issued due to DISIS-2015-002-4.
10/25/2018	SPP	Final report issued. Updated cost estimates, removed completed Previous Network Upgrade.
11/13/2018	SPP	Revised Final report issued. Updated cost estimates for Potter County Transformer.

CONTENTS

Revision History	i
Summary	1
Introduction	1
Phase(s) of Interconnection Service	1
Credits/Compensation for Amounts Advanced for Network Upgrade(s).....	1
Interconnection Customer Interconnection Facilities	2
Transmission Owner Interconnection Facilities and Non-Shared Network Upgrade(s).....	3
Shared Network Upgrade(s)	4
Previous Network Upgrade(s).....	6
Conclusion.....	6
Appendices.....	7
A: Transmission Owner’s Interconnection Facilities Study Report.....	8

SUMMARY

INTRODUCTION

This Interconnection Facilities Study (IFS) for Interconnection Request GEN-2015-056/IFS-2015-002-40 is for a 101.20 MW generating facility located in Roosevelt County, New Mexico. The Interconnection Request was studied in the DISIS-2015-002 Impact Study, DISIS-2015-002-1 Impact Restudy, DISIS-2015-002-2 Impact Restudy and DISIS-2015-002-4 Impact Restudy for Energy Resource Interconnection Service (ERIS). The Interconnection Customer's requested in-service date is December 1, 2017.

The interconnecting Transmission Owner, Southwestern Public Service Company (SPS), performed a detailed IFS at the request of SPP. The full report is included in Appendix A. SPP has determined that full Interconnection Service will be available after the assigned Transmission Owner Interconnection Facilities, Non-Shared Network Upgrade(s), and Shared Network Upgrade(s) are completed.

The primary objective of the IFS is to identify necessary Transmission Owner Interconnection Facilities, Network Upgrades, other direct assigned upgrades, cost estimates, and associated upgrade lead times needed to grant the requested Interconnection Service.

PHASE(S) OF INTERCONNECTION SERVICE

It is not expected that Interconnection Service will occur in phases. However, Interconnection Service will not be available until all Interconnection Facilities and Network Upgrade(s) can be placed in service.

CREDITS/COMPENSATION FOR AMOUNTS ADVANCED FOR NETWORK UPGRADE(S)

Interconnection Customer shall be entitled to compensation in accordance with Attachment Z2 of the SPP OATT for the cost of SPP creditable-type Network Upgrades, including any tax gross-up or any other tax-related payments associated with the Network Upgrades, that are not otherwise refunded to the Interconnection Customer. Compensation shall be in the form of either revenue credits or incremental Long Term Congestion Rights (iLTCR).

INTERCONNECTION CUSTOMER INTERCONNECTION FACILITIES

The Generating Facility is proposed to consist of forty-four (44) 2.3 MW General Electric (G.E.) wind generators for a total generating nameplate capacity of 101.20 MW.

The Interconnection Customer's Interconnection Facilities to be designed, procured, constructed, installed, maintained, and owned by the Interconnection Customer at its sole expense include:

- 34.5 kV underground cable collection circuits;
- 34.5 kV to 345 kV transformation substation with associated 34.5 kV and 345 kV switchgear;
- One (1) 345/34.5 kV 69/92/115 MVA (ONAN/ONAF/ONAF) step-up transformer to be owned and maintained by the Interconnection Customer at the Interconnection Customer's substation;
- A eight-and-a-half (8.5) mile overhead 345 kV line to connect the Interconnection Customer's substation to the POI at the 345 kV bus at the existing SPS substation ("Crossroads") that is owned and maintained by SPS;
- All transmission facilities required to connect the Interconnection Customer's substation to the POI;
- Equipment at the Interconnection Customer's substation necessary to maintain a power factor at the POI between 95% lagging and 95% leading, including approximately 8.6 Mvars¹ of reactors to compensate for injection of reactive power into the transmission system under no/reduced generating conditions. The Interconnection Customer may use wind turbine manufacturing options for providing reactive power under no/reduced generation conditions. The Interconnection Customer will be required to provide documentation and design specifications demonstrating how the requirements are met.

The Interconnection Customer shall coordinate relay, protection, control, and communication system configurations and schemes with the Transmission Owner.

¹ This approximate minimum reactor amount is needed for the current configuration of the wind farm as studied in the DISIS-2015-002 Impact Study and restudies.

TRANSMISSION OWNER INTERCONNECTION FACILITIES AND NON-SHARED NETWORK UPGRADE(S)

To facilitate interconnection, the interconnecting Transmission Owner will perform work as shown below necessary for the acceptance of the Interconnection Customer’s Interconnection Facilities.

Table 1 lists the Interconnection Customer’s estimated cost responsibility for Transmission Owner Interconnection Facilities (TOIF) and Non-Shared Network Upgrade(s) and provides an estimated lead time for completion of construction. The estimated lead time begins when the Generator Interconnection Agreement has been fully executed.

Table 1: Interconnection Customer TOIF and Non-Shared Network Upgrade(s)

TOIF and Non-Shared Network Upgrades Description	Z2 Type²	Allocated Cost Estimate (\$)	Allocated Percent (%)	Total Cost Estimate (\$)	Estimated Lead Time
<u>SPS Crossroads Interconnection Substation - Transmission Owner Interconnection Facilities:</u> Construct one (1) 345 kV line terminal, line switches, dead end structure, line relaying, communications, revenue metering, line arrester and all associated equipment and facilities necessary to accept transmission line from Interconnection Customer’s Generating Facility.	N/A	\$337,375	100%	\$337,375	24 Months
<u>SPS Crossroads Interconnection Substation - Non-Shared Network Upgrades:</u> Construct four (4) 345 kV 3000 continuous ampacity breakers, control panels, line relaying, disconnect switches, structures, foundations, conductors, insulators, and all other associated work and materials.	Non-Creditable	\$5,298,724	100%	\$5,298,724	
Total		\$5,636,099	100%	\$5,636,099	

An Electro-Magnetic Transient Program (EMTP) Study will be required after a GIA is signed to finalize any 345kV voltage shunt reactor configuration design, sizes, costs, and/or delivery.

² Indicates the method used for calculating credit impacts under Attachment Z2 of the Tariff.

SHARED NETWORK UPGRADE(S)

The Interconnection Customer’s share of costs for Shared Network Upgrades is estimated in **Table 2** below.

Table 2: Interconnection Customer Shared Network Upgrades

Shared Network Upgrades Description	Z2 Type	Allocated Cost Estimate (\$)	Allocated Percent (%)	Total Cost Estimate (\$)
<p><u>Border – Chisholm 345 kV Circuit #1 and #2:</u> Build twenty-four (24) miles of double 345 kV circuit from Border (OKGE) – Chisholm (AEP), convert Border 345 kV bus to breaker-and-a-half configuration for acceptance of the new line terminal and install seven (7) 345 kV 5000 continuous ampacity breakers, and expand Chisholm 345 kV bus for acceptance of the new line terminal by installing three (3) 345 kV 3000 continuous ampacity breakers. Border and Chisholm substations will require upgrades including: control panels, line relaying, disconnect switches, structures, foundations, conductors, insulators, and all other associated work and materials.</p> <p>Estimated Lead Time: 36 Months</p>	Creditable	\$7,627,070	10.46%	\$72,945,000 (AEP: \$42,945,000 OKGE: \$30,000,000)
<p><u>Crawfish Draw – Border 345 kV circuit #2:</u> Build one-hundred-ninety-four (194) miles of second 345 kV circuit from Crawfish Draw (SPS) – Border (OKGE), expand Crawfish Draw substation for acceptance of the new line terminal by installing one (1) 345 kV 3000 continuous ampacity breakers, and expand Crawfish Draw substation for acceptance of the new line terminal by installing one (1) 345 kV 5000 continuous ampacity breakers. Crawfish Drawn and Border substations will require upgrades including: control panels, line relaying, disconnect switches, structures, foundations, conductors, insulators, and all other associated work and materials.</p> <p>Estimated Lead Time: TBD</p>	Creditable	\$25,886,650	10.44%	\$247,951,345 (SPS: \$243,551,345 OKGE: \$4,400,000)
<p><u>SPS Crawfish 345/230 kV Substation Upgrade:</u> Tap Border – TUCO and Tap TUCO - Oklaunion approximately three (3) miles from TUCO, build Crawfish Draw 345 kV substation, add 345/230/13.2 kV transformer, and tie on TUCO – Swisher 230 kV.</p>	Creditable	\$5,476,138	22.11%	\$24,764,205
<p><u>SPS Potter County 345/230/13 kV Transformer Circuit #2:</u> Build second 345/230/13 kV transformer at Potter County. Along with this new 560 MVA transformer, install two (2) 345 kV circuit breakers, one (1) 230 kV</p>	Creditable	\$2,385,505	39.76%	\$6,000,379

Southwest Power Pool, Inc.

circuit breaker and associated substation terminal equipment.				
Total		\$41,375,363		\$351,660,929

All studies have been conducted assuming that higher-queued Interconnection Request(s) and the associated Network Upgrade(s) will be placed into service. If higher-queued Interconnection Request(s) withdraw from the queue, suspend or terminate service, the Interconnection Customer's share of costs may be revised. Restudies, conducted at the customer's expense, will determine the Interconnection Customer's revised allocation of Shared Network Upgrades.

PREVIOUS NETWORK UPGRADE(S)

Certain Previous Network Upgrades are currently not the cost responsibility of the Interconnection Customer but will be required for full Interconnection Service.

- None

Depending upon the status of higher- or equally-queued customers, the Interconnection Request’s in-service date is at risk of being delayed or Interconnection Service is at risk of being reduced until the in-service date of these Other Network Upgrades.

CONCLUSION

After all Interconnection Facilities and Network Upgrades have been placed into service, Interconnection Service for 101.20 MW can be granted. Interconnection Service will be delayed until the Transmission Owner Interconnection Facilities, Non-Shared Network Upgrade(s), and Shared Network Upgrade(s) are completed. The Interconnection Customer’s estimated cost responsibility for Transmission Owner Interconnection Facilities, Non-Shared Network Upgrade(s), and Shared Network Upgrade(s) are summarized in the table below.

Table 3: Cost Summary

Description	Allocated Cost Estimate
Transmission Owner Interconnection Facilities	\$337,375
Network Upgrades	\$46,674,087
Total	\$47,011,462

A draft Generator Interconnection Agreement will be provided to the Interconnection Customer consistent with the final results of this IFS report. The Transmission Owner and Interconnection Customer will have 60 days to negotiate the terms of the GIA consistent with the SPP Open Access Transmission Tariff (OATT).

APPENDICES

A: TRANSMISSION OWNER'S INTERCONNECTION FACILITIES STUDY REPORT

See next page for the Transmission Owner's Interconnection Facilities Study Report.



**Facilities Study For
Southwest Power Pool (SPP)**
GEN-2015-056
Total Output is 101.2 MW
Roosevelt County, New Mexico

Xcel Energy Services, Inc.
Transmission Planning South
January 27, 2016

Executive Summary

Interconnection Customer (IC) in 2015 requested an interconnection of a wind energy facility located in Roosevelt County, New Mexico to the Southwestern Public Service Company (SPS) transmission network to SPS's existing 345 kV Crossroads Switching Station. This facility has a net capacity of 101.2 MW, and the IC's requested commercial operation date of 12-01-2017.

The Southwest Power Pool (SPP) evaluated the request (GEN-2015-056) to interconnect the wind generation facility to the SPS transmission system in a Definitive Interconnection System Impact Study (DISIS-2015-002), which was completed in January 2016. The interconnection request was studied using forty-four (44) turbines, which are G.E. 2.3 MW wind turbines for a total of 101.2 MW. The IC is required to build 345 kV transmission line from their substation wind farm facility to the SPS's Crossroads Switching Station. The IC will be required to maintain a Power Factor between 0.95 lagging and 0.95 leading at the Point of Interconnection (POI).

SPP requires that each generator shall implement automatic Under Frequency Load Shedding (UFLS) according to the SPP UFLS Plan for SPS found in the Xcel Energy Interconnection Guidelines For Transmission Interconnected Producer-Owned Generation Greater Than 20 MW at the following link:

<http://www.transmission.xcelenergy.com/staticfiles/microsites/Transmission/Files/PDF/Interconnection/Interconnections-POL-TransmissionInterconnectionGuidelineGreat20MW.pdf>.

To fulfill this requirement, coordination with Xcel Energy is required during the under-frequency relay-setting phase for the generation. The Interconnection Customer is required to report their generation off-nominal frequency tripping relay settings to SPP and SPS. SPS specifies that generators shall not trip at frequencies above 58.5 Hz unless exceptions in the Transmission Provider Criteria are met. The Interconnection Customer agrees that the energy generating units installed at this interconnection will not be tripped for under-frequency conditions above 58.5 Hz in compliance with Transmission Provider criteria. This means that the generation subject to this Interconnection Agreement may not trip for under-frequency conditions on the transmission system until all under-frequency load shedding relays have operated. SPS will also require that the Interconnection Customer be in compliance with all applicable criteria, guidelines, standards, requirements, regulations, and procedures issued by the North American Electric Reliability Corporation (NERC), SPP, and the Federal Energy Regulatory Commission (FERC) or their successor organizations.

The Interconnection Customer is responsible for all costs of the Interconnection Facilities and Direct Assigned Transmission Owner Interconnection Facilities; inclusive of all construction required for the 345 kV to interconnect at SPS's Crossroads Switching Station.

The shared network upgrades will be determined at a later date by SPP and may impact the total overall costs for interconnection of the IC.

It is anticipated that the entire process of adding 345 kV breakers at Crossroads Switching Station for the acceptance of the IC facility output and the network upgrades allocated to this project will require approximately 24 months to complete after an Interconnection Agreement is signed and an authorization to proceed is received. The IC's cost for the interconnection of this Wind Farm facility is shown below in Table 1, with the detailed description of the cost shown in Table 3.

Table 1, Cost Summary^a

Shared Network Upgrades Total:	\$	TBD
Network Upgrades:	\$	5,298,724
Transmission Owner Interconnection Facilities:	\$	337,375
Total:	\$	5,636,099

^a The cost estimates are 2015 dollars with an accuracy level of ±20%.

General Description of SPS^b Facilities

1. **Construction of adding 345 kV breakers at Crossroads Switching Station:** See Appendix A, Figure A-1 for general vicinity location map.
 - 1.1. **Location:** Customer will build a new 345 kV line from their substation to SPS's 345 kV Crossroads Switching Station which includes three (3) new 345 kV breakers. Appendix A, Figure A-2, shows a preliminary one-line of Crossroads Switching Station, while Figure A-3 shows a typical elevation view of the normal Point of Interconnection (POI).
 - 1.2. **Bus Design:** The 345 kV Crossroads Switching Station will add another 345 kV string with three (3) 345 kV breakers to accommodate the output from the wind energy facility. This is shown in Appendix A, Figure A-2.
 - 1.3. **Line Terminals:** The 345 kV lines and static wire terminals will be designed to accommodate 14,000 pounds per phase conductor (28,000 Bundle) at maximum tension, with a maximum 15-degree pull off from normal.
 - 1.4. **Relay and Protection Scheme:** The new 345 kV breaker line terminal primary protection to the interconnection customer 345 kV transmission line will use line current differential relaying over optical fiber installed in the static of the customer's 345 kV transmission line. Secondary relaying will use mirrored bit, Permissive Overreaching Transfer Trip (POTT) over the optical fiber. An SEL 411L and an SEL 311C will be used as primary and secondary relays, respectively. The SEL 351S will be used for breaker SCADA closing conditions for the 345 kV breakers and for breaker failure.

An SEL 411L will display the line voltage, line amps, MW, MVAR, and fault location. A communication relay will be installed and for other functions as required.
 - 1.5. **Revenue Metering:** An individual billing meter will be installed at Crossroads Switching Station on the 345 kV line terminal from the IC's substation, which meets the standards: ANSI C12.1 accuracy class 0.2 (3-PT's IEEE C57.13 accuracy class 0.3 and 3-CT's IEEE C57.13 accuracy class 0.15) for full 3-phase 4-wire metering. There will be two meters per line terminal: one will be primary and the other will be back up, each will have full 4 quadrant metering. Pulses out of the primary billing meter will be sent via SCADA to the Transmission Owner's Control Center in Amarillo, Texas.
 - 1.6. **Disturbance Monitoring Device:** A Disturbance Fault Recorder (DFR), capable of recording faults, swings, and long term trending, will be installed to monitor and record conditions in the substation and on the transmission lines. The disturbance equipment shall also be equipped with a GPS time synching clock. This equipment will have communication capability with a dedicated communication circuit. The disturbance equipment will have its own dedicated communications circuit.
 - 1.7. **Remote Terminal Unit (RTU):** The existing RTU will be utilized with communications for the new switching station. A Communication SEL Relay will be installed for relay communications and other functions as required; these costs will be directly assigned to the IC. The IC will provide and install an RTU for metering and telemetry at the IC's facility as required by the latest Xcel Energy Interconnection Guidelines.

^b All modifications to SPS facilities will be owned, maintained and operated by SPS.

1.8. Communications: To meet its Communications obligations, the Interconnection Customer shall be responsible for making arrangements with the local phone company to provide a communication circuit as required by the Transmission Owner. Transmission Owner equipment may include, but is not limited to the following: relay communication equipment, RTU, and disturbance monitoring equipment at Crossroads Switching Station. Prior to any construction, the IC is required to contact the Transmission Owner substation-engineering department for all communication details and provide detail of the method to be used in communication.

The following communications schematic diagram, which includes communication equipment information for the IC, Transmission Provider (Southwest Power Pool) and Transmission Owner (Southwestern Public Service), is provided to assist the Parties as a template.

A schematic outlining the proposed communications is provided below:

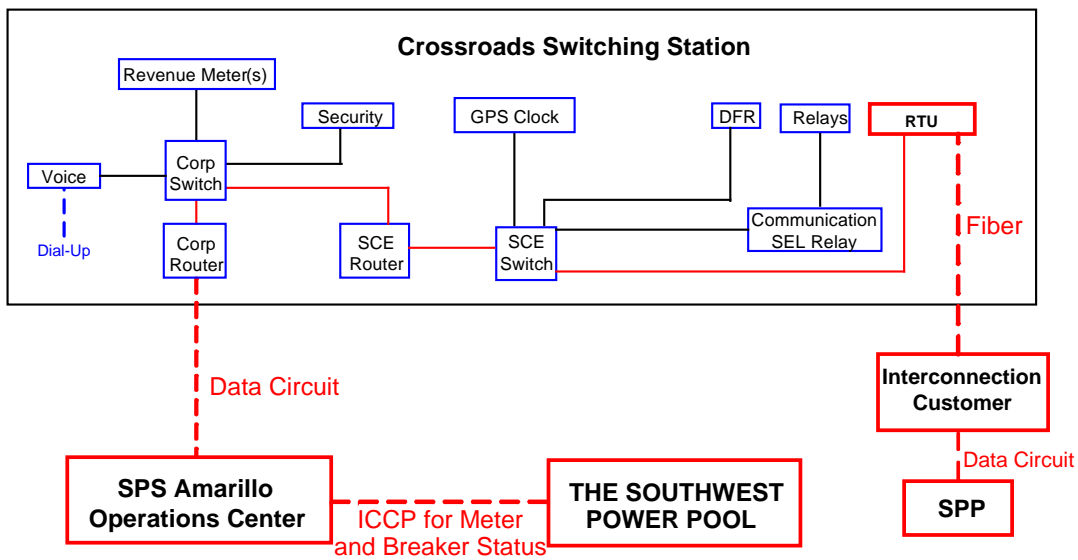

Interconnection Customer shall be responsible for providing fiber optic communication circuit installed in the overhead transmission line static wire from the customer substation to Crossroads Switching Station for protective relaying and for transmitting metering and status data to SPS. Utilizing this fiber optic connection, SPS will establish a direct connection to the IC's RTU.

SPS will not serve as a proxy for communication from the IC to SPP.

2. **Transmission Work:**

- 2.1 The SPS transmission design group prior to any construction by the Interconnection Customer or its contractor on any customer 345 kV transmission lines, or doing work in close proximity to any SPS transmission line, will require an engineering review of the customer's design. It is the Interconnection Customer's responsibility to initiate the design review in a timely manner before construction of any transmission line begins. If the review has not been made or the design at any of the aforementioned locations is deemed inadequate, the crossing(s) and or termination into the interchange will be delayed until the matters are resolved. SPS will not be held responsible for these delays.

3. **Right-Of-Way:**

- 3.1 **Permitting:** The IC will be responsible for any permitting and right of way of their substation and their transmission line from their substation to the Point of Interconnection at SPS's Switching Station.

Construction Power and Retail Service: It is the sole responsibility of the IC to make arrangements for both construction and station power. The IC needs to make arrangements for retail service from the local retail provider. Retail provider and Customer will be responsible for making any necessary transmission service arrangements as required under the SPP OATT.

4. **Project and Operating Concerns:**

- 4.1 Close work between the Transmission group, the Interconnection Customer's personnel and local operating groups will be imperative in order to meet any in-service date that has been established.
- 4.2 The Interconnection customer will be required to maintain a Power Factor between 0.95 lagging and a 0.95 leading at the Point of Interconnection (POI). All capacitors required will be installed on the lower voltage bus 34.5 kV at IC's substation. This is required to maintain acceptable dynamic voltage rise as per latest revision of the Xcel Energy Interconnection Guidelines for Transmission Interconnection Producer-Owned Generation Greater than 20 MW. If switched reactive devices are used on the IC's system, they need to be switched in stages where the voltage rise is less than 3%.

5. **Fault or Short Circuit Study:** The available fault current at the interconnection location using the 2015 MDWG 2020S with MMWG 2019S on the 345 kV at Crossroads Switching Station is shown in Table 2.

Table 2, - Available fault current at interconnection location

Short Circuit Information without contribution from new Generator Facilities (GEN 2015-056)				
Fault Location	Fault Current (Amps)		Impedance (Ω)	
	Line-to-Ground	3-Phase	Z^+	Z^0
345 kV Bus	3,792	4,512	4.46 + j44.38	17.20 + j68.33

Estimated Construction Costs

The projects required for the interconnection of 101.2 MW Wind Generation facilities consist of the projects summarized in the table below.

Table 3, Required Interconnection Projects^c

Project	Description	Estimated Cost
	Shared Network Upgrades:	
1	The shared network upgrades: (GEN-2015-056)	\$ TBD
	Subtotal:	\$ TBD
	Network Upgrades (funded by the IC)	
2	Add 4-345 kV breakers to an existing 4-breaker ring to convert to a breaker and a half.	\$ 5,298,724
	Subtotal:	\$ 5,298,724
	Transmission Owner Interconnection Facilities (direct assigned to the IC)	
3	Communications ^d	\$ See footnote
4	Revenue metering	\$ 280,000
5	345 kV Line arrestors	\$ 57,375
	Subtotal:	\$ 337,375
	Total Cost	\$ 5,727,346

An Electro-magnetic Transient Program (EMTP) Study will be required after an IA is signed. This will finalize any 345 kV or higher voltage shunt reactor sizes, cost and delivery.

Engineering and Construction:

An engineering and construction schedule for this project is estimated at approximately 24 months. Other factors associated with clearances, equipment delays and work schedules could cause additional delays. This is applicable after all required agreements are signed and internal approvals are granted.

All additional cost for work not identified in this study is the sole responsibility of the IC unless other arrangements are made.

^c The cost estimates are 2015 dollars with an accuracy level of ±20%.

^d It is the Requester's responsibility to provide both the data circuit and communication circuits, see Section 1.8.

Appendix A

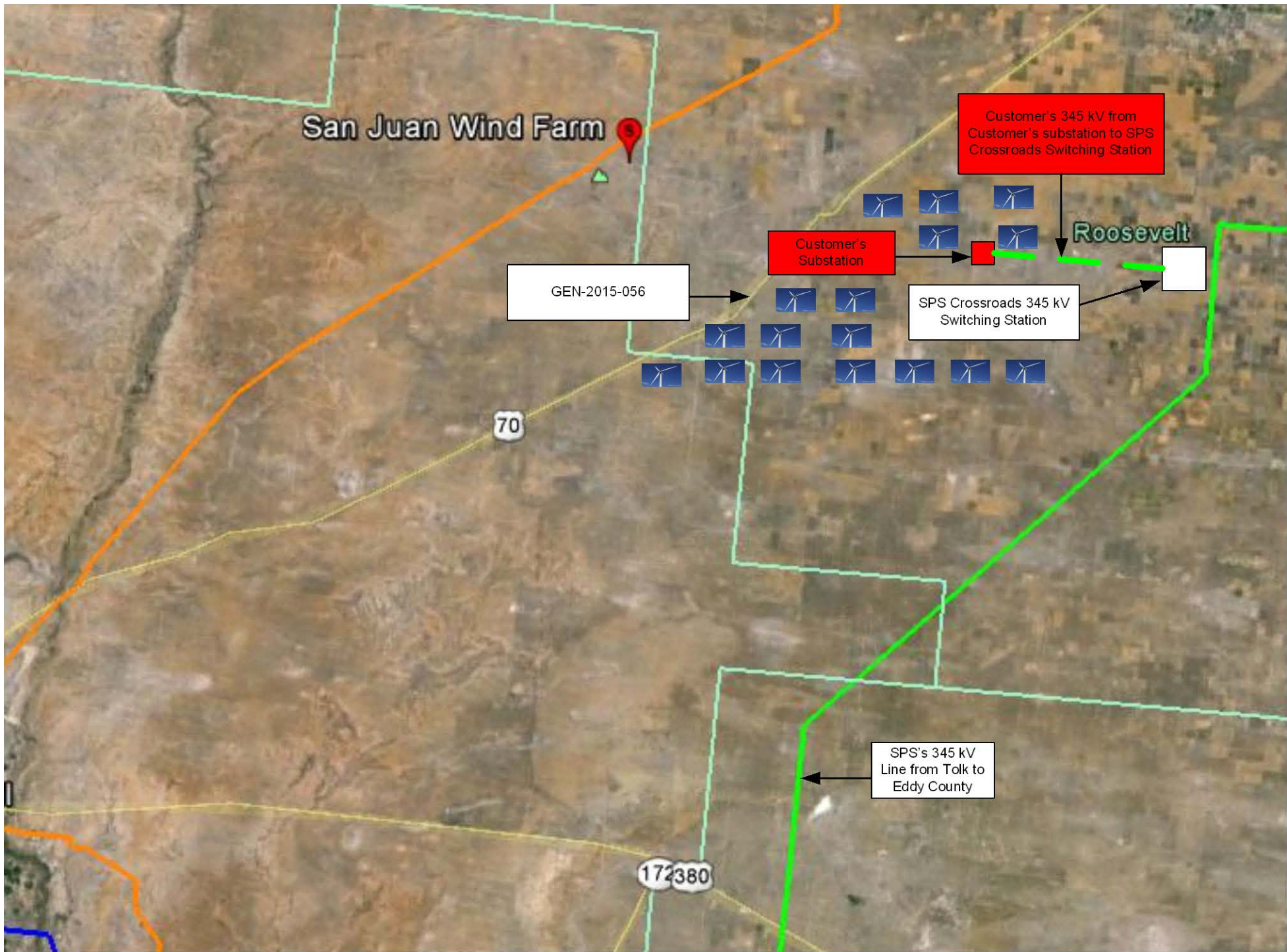
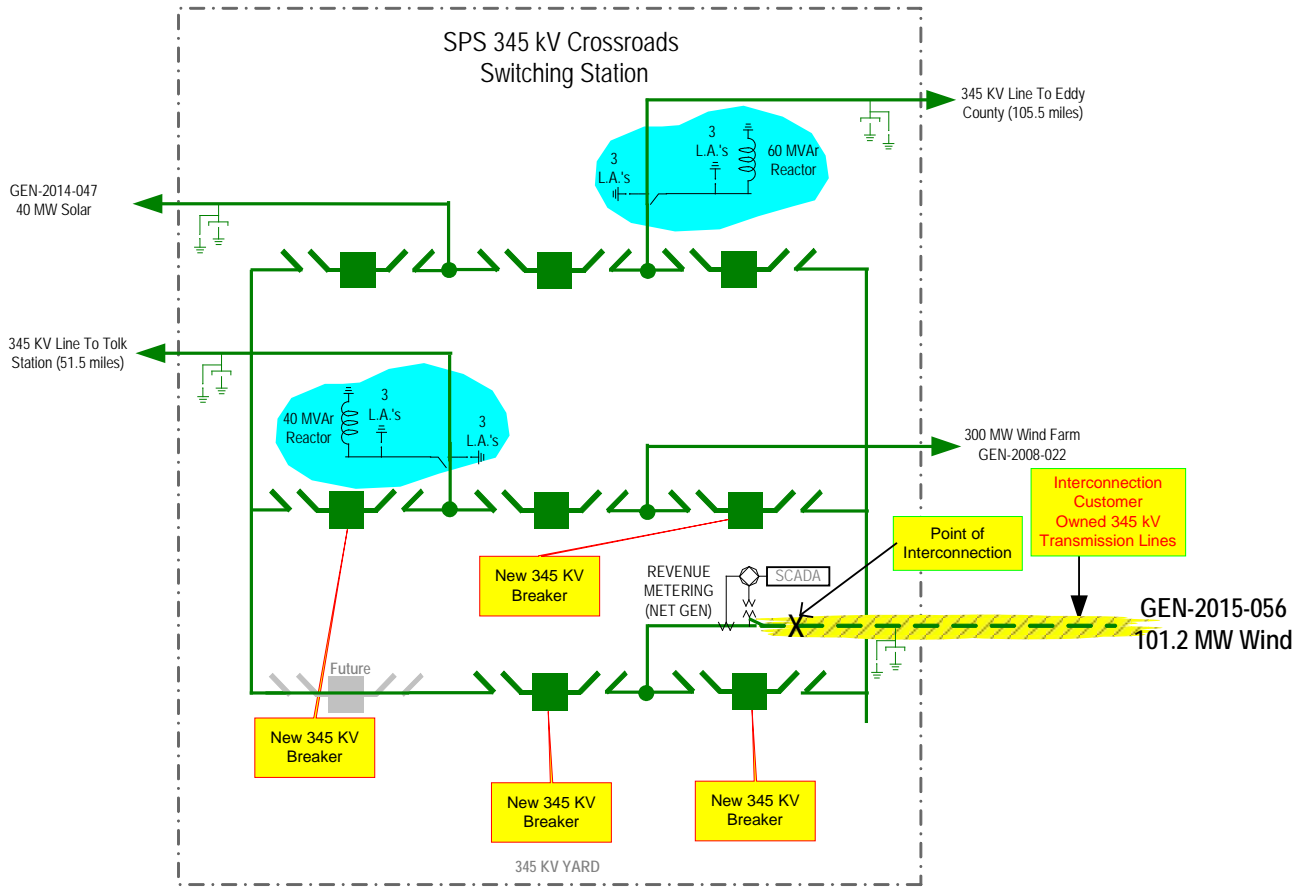

Figure A-1. Approximate location of Crossroads Switching Station and IC's Wind Farm



INTERCONNECTION FACILITY

PRELIMINARY ONE-LINE DRAWING :
FOR ILLUSTRATION PURPOSE ONLY
NOT FOR CONSTRUCTION

This is a typical layout of the breaker connection. Actual location will be determined later.

Figure A-2. One-line Diagram of New Crossroads Switching Station

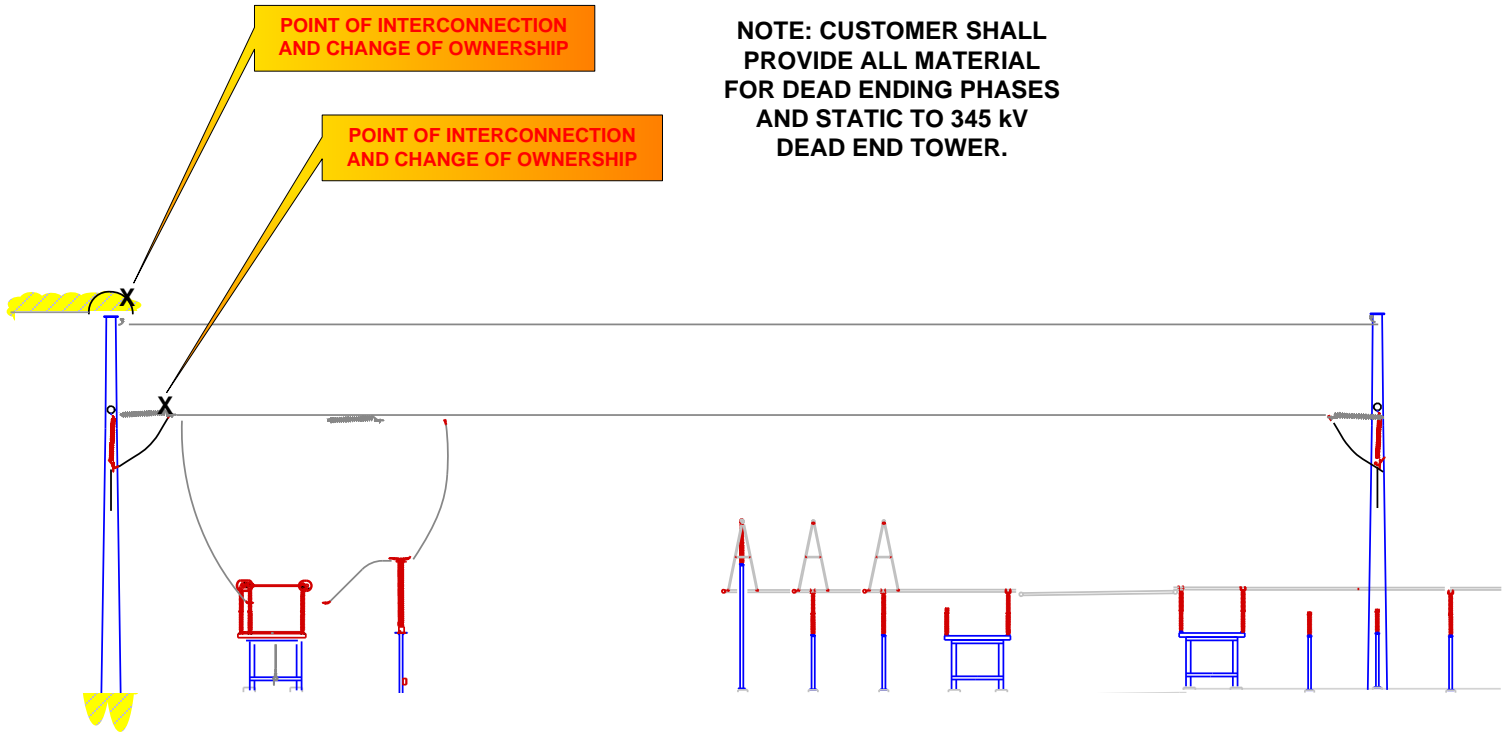

NOTE: CUSTOMER SHALL PROVIDE ALL MATERIAL FOR DEAD ENDING PHASES AND STATIC TO 345 kV DEAD END TOWER.

THIS DRAWING ILLUSTRATES ONLY THE POINT OF INTERCONNECTION AND THE BOUNDARIES OF CUSTOMERS RESPONSIBILITY. IT MAY NOT BE USED FOR CONSTRUCTION

Customer's Responsibility

Figure A-3 Point of Interconnection & Change of Ownership (Typical)

– END OF REPORT –