



Impact Study of Limited Operation for Generator Interconnection

GEN-2014-033

GEN-2014-034

October 2015
Generator Interconnection



Revision History

Date	Author	Change Description
10/15/2015	SPP	Impact Study of Limited Operation for Generator Interconnection GEN-2014-033 and GEN-2014-034 Report Issued

Executive Summary

<OMITTED TEXT> (Customer) has requested a Limited Operation System Impact Study under the Southwest Power Pool Open Access Transmission Tariff (OATT) for 140 MW of solar generation to be interconnected with Energy Resource Interconnection Service (ERIS) into the Transmission System of Southwest Public Service (SPS) in Chaves County, Texas. GEN-2014-033 and GEN-2014-034 under GIA Section 5.9, has requested this Limited Operation Interconnection Study (LOIS) to determine the impacts of interconnecting to the transmission system before all required Network Upgrades identified in the DISIS-2014-002 (or most recent iteration) Impact Study can be placed into service.

This LOIS addresses the effects of interconnecting the generators to the rest of the transmission system for the system topology and conditions as expected on November 1, 2016. GEN-2014-033 and GEN-2014-034 is requesting the interconnection two hundred eighty (280) SMA 0.5 MW SC 500HE/CP 0.5MVA solar inverters and associated facilities interconnecting at the Chaves 115kV substation in Chaves County, Texas. For this LOIS, power flow analysis was conducted. The LOIS assumes that only the higher queued projects listed within Table 1 of this study might go into service before the completion of all Network Upgrades identified within Table 2 of this report. If additional generation projects, listed within Table 3, with queue priority equal to or higher than the study project request rights to go into commercial operation before all Network Upgrades identified within Table 2 of this report are completed, this LOIS may need to be restudied to ensure that interconnection service remains for the customer's request.

Power flow analysis from this LOIS has determined that the GEN-2014-033 and GEN-2014-034 request can interconnect their generation with Energy Resource prior to the completion of the required Network Upgrades, listed within Table 2 of this report. Should any other projects, other than those listed within Table 1 of this report, come into service an additional study may be required to determine if any limited operation service is available. Refer to Table 6, Table 7, Table 8 and Table 9 for the Limited Operation Interconnection Service available due to interconnection constraints. It should be noted that although this LOIS analyzed many of the most probable contingencies, it is not an all-inclusive list that can account for every operational situation. Additionally, the generator may not be able to inject any power onto the Transmission System due to constraints that fall below the threshold of mitigation for a Generator Interconnection request. Because of this, it is likely that the Customers may be required to reduce their generation output to **0 MW** under certain system conditions to allow system operators to maintain the reliability of the transmission network.

Transient stability analysis was not performed for this LOIS study. The results from DISIS 2014-002 or latest iteration remain valid.

Nothing in this study should be construed as a guarantee of delivery or transmission service. If the customer wishes to sell power from the facility, a separate request for transmission service must be requested on Southwest Power Pool's OASIS by the Customer.

Table of Contents

Revision History	i
Executive Summary	i
Table of Contents	ii
Purpose	1
Facilities	5
Generating Facility	5
Interconnection Facilities	5
Base Case Network Upgrades	5
Power Flow Analysis	7
Model Preparation	7
Study Methodology and Criteria	7
Results	7
Curtailment and System Reliability	8
Stability Analysis	11
Conclusion	12

Purpose

<OMITTED TEXT> (Interconnection Customer) has requested a Limited Operation System Impact Study (LOIS) under the Southwest Power Pool (SPP) Open Access Transmission Tariff (OATT) for interconnection requests into the Transmission System of Southwest Public Service (SPS).

The purpose of this study is to reevaluate the impacts of interconnecting GEN-2014-033 and GEN-2014-034 requests are a total of 140 MW comprised of two hundred eighty (280) SMA 0.5 MW SC 500HE/CP 0.5MVA solar inverters and associated facilities interconnecting at the Chaves 115kV substation in Chaves County, Texas. The Customer has requested this amount to be studied with Energy Resource Interconnection Service (ERIS) and Network Resource Interconnection Service (NRIS) to commence on or around November 2016.

Only power flow analysis was conducted for this Limited Operation Interconnection Service. Limited Operation Studies are conducted under GIA Section 5.9.

The LOIS considers the Base Case as well as all Generating Facilities (and with respect to (b) below, any identified Network Upgrades associated with such higher queued interconnection) that, on the date the LOIS is commenced:

- a) are directly interconnected to the Transmission System;
- b) are interconnected to Affected Systems and may have an impact on the Interconnection Request;
- c) have a pending higher queued Interconnection Request to interconnect to the Transmission System listed in Table 1; or
- d) have no Queue Position but have executed an LGIA or requested that an unexecuted LGIA be filed with FERC.

Any changes to these assumptions, for example, one or more of the previously queued requests not included within this study execute an interconnection agreement and commencing commercial operation, may require a re-study of this LOIS at the expense of the Customer.

Nothing within this System Impact Study constitutes a request for transmission service or confers upon the Interconnection Customer any right to receive transmission service rights. Should the Customer require transmission service, those rights should be requested through SPP's Open Access Same-Time Information System (OASIS).

This LOIS study included prior queued generation interconnection requests. Those listed within Table 1 are the generation interconnection requests that are assumed to have rights to either full or partial interconnection service prior to the requested November 2016 in-service for this LOIS. Also listed in Table 1 are both the amount of MWs of interconnection service expected at the effective time of this study and the total MWs requested of interconnection service, the fuel type, the point of interconnection (POI), and the current status of each particular prior queued request.

Table 1: Generation Requests Included within LOIS

Project	MW	Total MW	Fuel Source	POI	Status
ASGI-2010-010	42.2	42.2		Lovington 115kV	
ASGI-2010-020	30	30		Tap LE Tatu – LE Crossroads 69kV	
ASGI-2010-021	15	15		Tap LE-Saunders Tap – LE Anderson 69kV	
ASGI-2011-001	27.3	27.3		Lovington 115kV	
ASGI-2011-003	10	10		Hendricks 115kV	
ASGI-2011-004	20	20		Pleasant Hill 69kV	
ASGI-2012-002	18.15	18.15		FE-Clovis Interchange 115kV	
ASGI-2013-005	1.65	1.65		FE Clovis 115kV	
ASGI-2013-006	2	2		SP-Erskine 115kV	
ASGI-2014-001	2.5	2.5		SP-Erskine 115kV	
ASGI-2014-005	10	10		Strata 69kV	
ASGI-2014-008	10	10		South Loving 69kV	
ASGI-2014-009	10	10		Wood Draw 115kV	
ASGI-2014-010	10	10		Ochoa 115kV	
ASGI-2014-012	10	10		Cooper Ranch 115kV	
GEN-2001-033	120	180	Wind	San Juan Tap 230kV	IA Fully Executed/Commercial Operation
GEN-2001-036	80	80	Wind	Norton 115kV	IA Fully Executed/Commercial Operation
GEN-2006-018	170	170	CT	TUCO Interchange 230kV	IA Fully Executed/Commercial Operation
GEN-2006-026	502	502	Gas	Hobbs 230kV & Hobbs 115kV	IA Fully Executed/Commercial Operation
GEN-2008-022	300	300	Wind	Tap Tolk - Eddy County (Crossroads) 345kV	IA Fully Executed /On Schedule
GEN-2010-006	205	205	Gas	Jones 230kV	IA Fully Executed/Commercial Operation
GEN-2010-046	56	56	Gas		IA Fully Executed /On Schedule
GEN-2011-025	80	80	Wind	Tap Floyd County - Crosby County 115kV	IA Fully Executed /On Schedule
GEN-2011-045	205	205	NG CT		IA Fully Executed/Commercial Operation
GEN-2011-046	27	27	Diesel CT	Lopez 115kV	IA Fully Executed/Commercial Operation
GEN-2011-048	175	175	CT	Mustang 230kV	IA Fully Executed/Commercial Operation
GEN-2012-001	61.2	61.2	Wind	Cirrus Tap 230kV	IA Fully Executed/Commercial Operation
GEN-2012-020	478	478	Wind	TUCO 230kV	IA Fully Executed /On Schedule
GEN-2012-034	7	7	CT	Mustang 230kV	IA Fully Executed /On Schedule
GEN-2012-035	7	7	CT	Mustang 230kV	IA Fully Executed /On Schedule
GEN-2012-036	7	7	CT	Mustang 230kV	IA Fully Executed/Commercial Operation
GEN-2012-037	203	203	CT	TUCO 345kV	IA Fully Executed /On Schedule
GEN-2013-016	203	203	CT	TUCO 345kV	IA Fully Executed /On Schedule
GEN-2013-022	25	25	Solar	Norton 115kV	IA Fully Executed/On Schedule
GEN-2013-027	150	150	Wind	Tap Tolk-Yoakum 230kV	GIA Pending
GEN-2014-035	30	30	Solar	Chaves County 115kV	GIA Pending
GEN-2014-047	20	40	Solar	Tap Tolk - Eddy County (Crossroads) 345kV	GIA Pending
GEN-2014-053	80	80	Wind	Carlisle 230kV	GIA Pending
GEN-2014-054	120	120	Wind	Carlisle 230kV	GIA Pending
GEN-2014-033	70	70	Solar	Chaves County 115kV	GIA Pending
GEN-2014-034	70	70	Solar	Chaves County 115kV	GIA Pending

An additional scenario was studied without GEN 2013-027, GEN 2014-035, GEN 2014-053 and GEN-2014-054 in service.

This LOIS was required because the Customers are requesting interconnection prior to the completion of all of their required upgrades listed within the latest iteration of their Definitive Interconnection System Impact Study (DISIS). Table 2 below lists the required upgrade projects for which these requests have cost responsibility. GEN-2014-033, and GEN-2014-034 were included within the DISIS-2014-002 that was studied in fall 2014 and posted January 31, 2015. The cluster has been restudied since the original posting. These reports can be located at the following Generation Interconnection Study URL:

http://sppoasis.spp.org/documents/swpp/transmission/GenStudies.cfm?YearType=2014_Impact_Studies

Table 2: Upgrade Projects not included but Required for Full Interconnection Service

Upgrade Project	Type	Description	Status
Tolk – Plant X 230kV circuit #1 and #2	Rebuild	Rebuild 230kV circuit #1 and #2 between Tolk and Plant X	
Tuco 2 Substation Upgrade 345kV/230kV	New Substation	Tap Border – Tuco 345kV and build new 345kV substation and 345/230kV transformer and tie on TUCO – Swisher 230kV	

Any changes to these assumptions, for example, one or more of the previously queued requests not included within this study execute an interconnection agreement and commencing commercial operation, may require a re-study of this LOIS at the expense of the Customer.

The higher or equally queued projects that were not included in this study are listed in Table 3. While this list is not all inclusive it is a list of the most probable and affecting prior queued requests that were not included within this LOIS, either because no request for an LOIS has been made or the request is on suspension, etc.

Table 3: Higher or Equally Queued GI Requests not included within LOIS

Project	MW	Total MW	Fuel Source	POI	Status
ASGI-2013-002	0	18.4		FE Tucumcari 115kV	
ASGI-2013-003	0	18.4		FE Clovis 115kV	
ASGI-2014-002	0	49.6		Tap Tucumcari – Santa Rosa 115kV	
GEN-2001-033(uninstalled capacity)	120	180	Wind	San Juan Tap 230kV	IA FULLY EXECUTED/COMMERCIAL OPERATION
GEN-2014-035	0	30	Solar	Chaves 115kV	Facility Study

The customer requested a scenario with the following generation changes listed in Table 4. This scenario was studied with and without GEN 2013-027, GEN 2014-035, GEN 2014-053 and GEN-2014-054 in service.

Table 4: Higher or Equally Queued GI Requests not included within LOIS

Project	MW	Total MW	Fuel Source	POI	Status
GEN-2014-047	20	40	Solar	Tap Tolk - Eddy County (Crossroads) 345kV	Facility Study

Additionally, the customer requested a scenario with the following generation changes listed in Table 5. This scenario was also studied with and without GEN 2013-027, GEN 2014-035, GEN 2014-053 and GEN-2014-054 in service.

Table 5: Higher or Equally Queued GI Requests not included within LOIS

Project	MW	Total MW	Fuel Source	POI	Status
GEN-2012-020	360	478	Wind	TUCO 230kV	IA Fully Executed /On Schedule
GEN-2014-047	20	40	Solar	Tap Tolk - Eddy County (Crossroads) 345kV	Facility Study

Nothing in this System Impact Study constitutes a request for transmission service or grants the Interconnection Customer any rights to transmission service.

Facilities

Generating Facility

The Interconnection Customer’s request to interconnect a total of 140 MW is comprised of two hundred eighty (280) SMA 0.5 MW SC 500HE/CP 0.5MVA solar inverters and associated facilities.

Interconnection Facilities

The POI for GEN-2014-033, and GEN-2014-034 Interconnection Customer is the Chaves 115kV substation in Chaves County, Texas. Figure 1 depicts the one-line diagram of the local transmission system including the POI as well as the power flow model representing the requests.

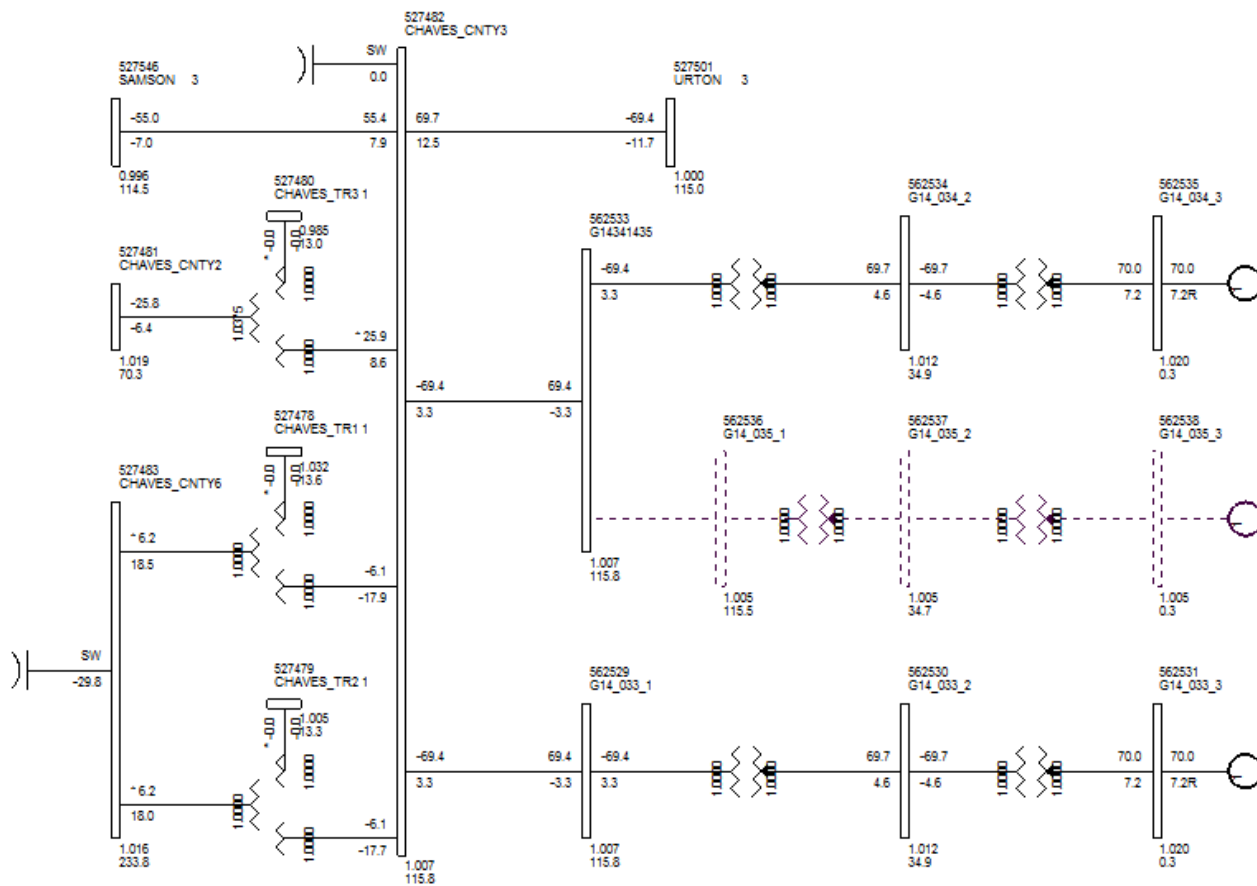

Figure 1: Proposed POI Configuration and Request Power Flow Model

Base Case Network Upgrades

The Network Upgrades included within the cases used for this LOIS study are those facilities that are a part of the SPP Transmission Expansion Plan or the Balanced Portfolio projects that have in-service dates prior to the GEN-2014-033 and GEN-2014-034 LOIS requested in-service date of November 1, 2016. These facilities have an approved Notification to Construct (NTC), or are in construction stages and expected to be in-service at the effective time of this study. No other

upgrades were included for this LOIS. If for some reason, construction on these projects is delayed or discontinued, a restudy may be needed to determine the interconnection service availability of the Customer.

Power Flow Analysis

Power flow analysis is used to determine if the transmission system can accommodate the injection from the request without violating thermal or voltage transmission planning criteria.

Model Preparation

Power flow analysis was performed using modified versions of the 2014 series of transmission service request study models including the 2015 (spring and summer) seasonal models. To incorporate the Interconnection Customer's request, a re-dispatch of existing generation within SPP was performed with respect to the amount of the Customer's injection and the interconnecting Balancing Authority. This method allows the request to be studied as an Energy Resource (ERIS) Interconnection Request. For this LOIS, only the previous queued requests listed in Table 1 were assumed to be in-service.

Study Methodology and Criteria

The ACCC function of PSS/E is used to simulate contingencies, including single and multiple facility (i.e. breaker-to-breaker, etc.) outages, within all of the control areas of SPP and other control areas external to SPP and the resulting data analyzed. This satisfies the "more probable" contingency testing criteria mandated by NERC and the SPP criteria.

The contingency set includes all SPP control area branches and ties 69kV and above, first tier Non-SPP control area branches and ties 115 kV and above, any defined contingencies for these control areas, and generation unit outages for the SPP control areas with SPP reserve share program redispatch.

The monitor elements include all SPP control area branches, ties, and buses 69 kV and above, and all first tier Non-SPP control area branches and ties 69 kV and above. NERC Power Transfer Distribution Flowgates for SPP and first tier Non-SPP control area are monitored. Additional NERC Flowgates are monitored in second tier or greater Non-SPP control areas. Voltage monitoring was performed for SPP control area buses 69 kV and above.

Results

The LOIS ACCC analysis indicates that the Customers can interconnect their generation into the SPS transmission system at a reduced rate before all required upgrades listed within the DISIS-2014-002 study or latest iteration can be placed into service. Should any other GI projects, other than those listed within Table 1 of this report, come into service an additional study may be required to determine if any limited operation service is available.

ACCC results for the LOIS can be found in Table 6, Table 7, Table 8, Table 9, and Table 10 below. Table 10 has the overloads that are less than 20% TDF and are not for mitigation. Generator Interconnection Energy Resource analysis doesn't mitigate for those issues in which the affecting GI request has less than a 20% OTDF, Table 10 is provided for informational purposes only so that the Customer understands there may be operational conditions when they may be required to reduce their output to maintain system reliability.

Curtailment and System Reliability

In no way does this study guarantee operation for all periods of time. It should be noted that although this study analyzed many of the most probable contingencies, it is not an all-inclusive list and cannot account for every operational situation. Because of this, it is likely that the Customer may be required to reduce their generation output to **0 MW** under certain system conditions to allow system operators to maintain the reliability of the transmission network.

Power Flow Analysis

Table 6: Constraints for Mitigation of LOIS @ 140MW without GEN 2013-027, GEN 2014-035, GEN 2014-053 and GEN 2014-054

Season	Dispatch Group	Source	Flow	Monitored Element	RATEA (MVA)	RATEB (MVA)	TDF	TC% LOADING	Max MW Available	Contingency
15SP	06ALL	G14_033	TO->FROM	PLANT X STATION - TOLK STATION WEST 230KV CKT 1	478	502	0.36806	101.153	64.56	PLANT X STATION - TOLK STATION EAST 230KV CKT 2
15SP	06ALL	G14_034	TO->FROM	PLANT X STATION - TOLK STATION WEST 230KV CKT 1	478	502	0.36806	101.153	64.56	PLANT X STATION - TOLK STATION EAST 230KV CKT 2
15SP	06ALL	G14_033	TO->FROM	PLANT X STATION - TOLK STATION EAST 230KV CKT 2	478	502	0.36482	100.3778	68.2	PLANT X STATION - TOLK STATION WEST 230KV CKT 1
15SP	06ALL	G14_034	TO->FROM	PLANT X STATION - TOLK STATION EAST 230KV CKT 2	478	502	0.36482	100.3778	68.2	PLANT X STATION - TOLK STATION WEST 230KV CKT 1

Table 7: Constraints for Mitigation of LOIS @ 140MW with GEN 2013-027, GEN 2014-035, GEN 2014-053 and GEN 2014-054

Season	Dispatch Group	Source	Flow	Monitored Element	RATEA (MVA)	RATEB (MVA)	TDF	TC% LOADING	Max Available	Contingency
15SP	06ALL	G14_033	TO->FROM	PLANT X STATION - TOLK STATION WEST 230KV CKT 1	478	502	0.36631	119.272	25.04	PLANT X STATION - TOLK STATION EAST 230KV CKT 2
15SP	06ALL	G14_034	TO->FROM	PLANT X STATION - TOLK STATION WEST 230KV CKT 1	478	502	0.36631	119.272	25.04	PLANT X STATION - TOLK STATION EAST 230KV CKT 2
15SP	06ALL	G14_033	TO->FROM	PLANT X STATION - TOLK STATION EAST 230KV CKT 2	478	502	0.36308	118.359	26.75	PLANT X STATION - TOLK STATION WEST 230KV CKT 1
15SP	06ALL	G14_034	TO->FROM	PLANT X STATION - TOLK STATION EAST 230KV CKT 2	478	502	0.36308	118.359	26.75	PLANT X STATION - TOLK STATION WEST 230KV CKT 1
15G	06ALL	G14_033	FROM->TO	TUCO INTERCHANGE (GE M1022338) 345/230/13.2KV TRANSFORMER CKT 1	560	560	0.41745	109.9878	48.61	TUCO INTERCHANGE (SIEM 8743066) 345/230/13.2KV TRANSFORMER CKT 2
15G	06ALL	G14_034	FROM->TO	TUCO INTERCHANGE (GE M1022338) 345/230/13.2KV TRANSFORMER CKT 1	560	560	0.41745	109.9878	48.61	TUCO INTERCHANGE (SIEM 8743066) 345/230/13.2KV TRANSFORMER CKT 2

Table 8: Constraints for Mitigation of LOIS @ 140MW without GEN 2013-027, GEN 2014-035, GEN 2014-053 and GEN 2014-054 and GEN 2012-020 @ 360MW

Season	Dispatch Group	Source	Flow	Monitored Element	RATEA (MVA)	RATEB (MVA)	TDF	TC% LOADING	Max Available	Contingency
ALL		G14_033		No Interconnection Constraints					70	
ALL		G14_034		No Interconnection Constraints					70	

Power Flow Analysis

Table 9: Constraints for Mitigation of LOIS @ 140MW with GEN 2013-027, GEN 2014-035, GEN 2014-053 and GEN 2014-054 and GEN 2012-020 @ 360MW

Season	Dispatch Group	Source	Flow	Monitored Element	RATE A (MVA)	RATEB (MVA)	TDF	TC% LOADING	Max Available	Contingency
15SP	06ALL	G14_033	TO->FROM	PLANT X STATION - TOLK STATION WEST 230KV CKT 1	478	502	0.3663	117.1989	29.88	PLANT X STATION - TOLK STATION EAST 230KV CKT 2
15SP	06ALL	G14_034	TO->FROM	PLANT X STATION - TOLK STATION WEST 230KV CKT 1	478	502	0.3663	117.1989	29.88	PLANT X STATION - TOLK STATION EAST 230KV CKT 2
15SP	06ALL	G14_033	TO->FROM	PLANT X STATION - TOLK STATION EAST 230KV CKT 2	478	502	0.36308	116.3023	31.59	PLANT X STATION - TOLK STATION WEST 230KV CKT 1
15SP	06ALL	G14_034	TO->FROM	PLANT X STATION - TOLK STATION EAST 230KV CKT 2	478	502	0.36308	116.3023	31.59	PLANT X STATION - TOLK STATION WEST 230KV CKT 1

Table 10: Constraints not for mitigation @ 140MW

Available upon request.

Stability Analysis

Transient stability analysis was not performed for this LOIS study. The results from DISIS 2014-002 or most recent iteration remain valid.

Conclusion

<OMITTED TEXT> (Interconnection Customer) has requested a Limited Operation System Impact Study under the Southwest Power Pool Open Access Transmission Tariff (OATT) for a total of 140MW of solar generation to be interconnected with Energy Resource Interconnection Service (ERIS) into the Transmission System of Southwest Public Service (SPS) in Chaves County, Texas. The point of interconnection will be the Chaves 115kV substation. GEN-2014-033 and GEN-2014-034 under GIA Section 5.9, have requested this Limited Operation Interconnection Study (LOIS) to determine the impacts of interconnecting to the transmission system before all required Network Upgrades identified in the DISIS-2014-002 (or most recent iteration) Impact Study can be placed into service.

Power flow analysis from this LOIS has determined that GEN-2014-033 and GEN-2014-034, request can interconnect their generation at a reduced total MW as an Energy Resource prior to the completion of the required Network Upgrades, listed within Table 2 of this report. Should any other projects, other than those listed within Table 1 of this report, come into service an additional study may be required to determine if any limited operation service is available. Refer to Table 6, Table 7, Table 8 and Table 9 for the Limited Operation Interconnection Service available due to interconnection constraints.

Transient stability analysis was not performed for this LOIS study. The results from DISIS 2014-002 or most recent iteration remain valid.

Any changes to these assumptions, for example, one or more of the previously queued requests not included within this study execute an interconnection agreement and commencing commercial operation, may require a re-study of this LOIS at the expense of the Customer.

Nothing in this System Impact Study constitutes a request for transmission service or confers upon the Interconnection Customer any right to receive transmission service.