



SPP

*Southwest
Power Pool*

**Affected System Interconnection
Facilities Study
For
Generator Interconnection
Request
ASGI-2014-009**

***SPP Generator
Interconnection Studies***

(#ASGI-2014-009)

February 2016

Revision History

Date	Author	Change Description
9/18/2015	SPP	Final Affected System Interconnection Facilities Study Report Revision 0 Issued
11/12/2015	SPP	Final Affected System Interconnection Facilities Study Report Revision 1 Issued Accounting for DISIS-2014-002-4 Network Upgrade(s)
2/2/2016	SPP	Facilities Study Report Revised for changes in Shared Network Upgrades

Summary

Southwestern Public Service Company (SPS), an operating company subsidiary of Xcel Energy Inc., performed a detailed Affected System Interconnection Facilities Study at the request of Southwest Power Pool (SPP) for Affected System Generator Interconnection (ASGI) Request ASGI-2014-009, a 10.0 MW solar generating facility located in Eddy County, New Mexico. The ASGI-2014-009 request is for interconnection to SPS 12.47kV distribution network served from SPS Wood Draw 115kV. The original proposed in-service date for ASGI-2014-009 was December 1, 2016. SPP has proposed the full interconnection service in-service date will be after the assigned Interconnection Facilities, Non-Shared Network Upgrade(s), and Shared Network Upgrade(s) are completed. Full Interconnection Service will require the Network Upgrade(s) listed in the “Other Network Upgrades” section.

Affected System Interconnection Customer Interconnection Facilities

The Affected System Interconnection Customer’s generation facility consists of ten (10) units of one (1) MW Advanced Energy (A.E.) 1000NX solar inverters for a total generating rating of 10.0 MWs. The solar generating facility is planned to be connected by a short (< 1 mile) overhead transmission circuit to the Point of the Interconnection at SPS 12.47kV distribution network bus at the SPS Wood Draw Substation. The Affected System Interconnection Customer will be responsible for all of the transmission facilities connecting the customer owned substation to the Point of Interconnection (POI), at the 12.47kV bus at the Wood Draw Substation. The Wood Draw distribution network connects to the SPS transmission network from the Wood Draw 115/12.47kV transformer.

Affected System Transmission Owner Interconnection Facilities and Non-Shared Network Upgrade(s)

To facilitate Affected System Interconnection the Affected System Transmission Owner will need to install revenue metering equipment for acceptance of the Affected System Interconnection Customer’s Interconnection Facilities. At this time ASGI-2014-009 is responsible for \$16,000 of Affected System Transmission Owner Interconnection Facilities and Non-Shared Network Upgrade(s). **Table 1** displays the estimated costs for Transmission Owner Interconnection Facilities and Non-Shared Network Upgrades. Currently, SPS estimates an Engineering and Construction (E&C) lead time of approximately twelve (12) months after a fully executed Affected Systems’ Facilities Construction Agreement (ASFCA) for the completion of Affect System Transmission Owner Interconnection Facilities and Non-Shared Network Upgrades. In addition to the Affected System Transmission Owner Interconnection Facilities and Non-Shared Network Upgrade(s), the Affected System Interconnection Customer or Host Distribution Provider shall be responsible to provide Supervisory Control and Data Acquisition (SCADA) and accumulator data to the SPS Control Center. A diagram intended to assist the Affected System Interconnection Customer can be found in the Xcel Affected System Interconnection Facilities System Report in **Section 1.5**.

Table 1: ASGI-2014-009 Affect System TOIF and Non-Shared Network Upgrades

Affected System Transmission Owner Interconnection Facilities and Non-Shared Network Upgrades Description	Allocated Cost (\$)	Allocated Percent (%)	Total Cost (\$)
Affected System Interconnection Substation - Transmission Owner Interconnection Facilities 69kV Substation work	\$0	N/A	\$0
Affected System Interconnection Substation - Transmission Owner Interconnection Facilities 69kV Substation work for revenue metering and communications	\$16,000	100%	\$16,000
Total	\$16,000	100%	\$16,000

Shared Network Upgrade(s)

The Affected Interconnection Request was studied within the DISIS-2014-002 Impact Study, and its subsequent restudies, the latest iteration being DISIS-2014-002-5. At this time, the Affected System Interconnection Customer is allocated \$159,022 for Shared Network Upgrade(s). If higher queued interconnection customers withdraw from the queue, suspend or terminate their GIA, restudies will have to be conducted to determine the Affected System Interconnection Customers’ allocation of Shared Network Upgrade(s). All studies have been conducted on the basis of higher queued interconnection requests and the upgrades associated with those higher queued interconnection requests being placed in service. At this time, the Interconnection Customer is allocated the following cost for Shared Network Upgrade(s):

Table 2: ASGI-2014-009 Shared Network Upgrades

Shared Network Upgrades Description	Allocated Cost (\$)	Allocated Percent (%)	Total Cost (\$)
Tolk - Plant X 230kV Circuit #1 & #2: Rebuild Tolk - Plant X circuits #1 and #2	\$159,022	1.54	\$9,921,693
Total	\$159,022		\$9,921,693

Affected System Previous Network Upgrade(s)

Certain Other Network Upgrade(s) are currently not the cost responsibility of the Customer but will be required for full Interconnection Service. Currently, the following Other Network Upgrade(s) are assigned to ASGI-2014-009:

- Agave Hill 115kV Reactive Power Support build assigned in 2015 Integrated Transmission Plan Near Term Assessment (ITPNT) per SPP-NTC-C-200324
- China Draw 115kV Reactive Power Support build assigned in 2015 Integrated Transmission Plan Near Term Assessment (ITPNT) per SPP-NTC-C-200324
- Hobbs Interchange - Kiowa 345kV Transmission circuit #1 assigned in the High Priority Increment Load Study (HPILs) per SPP-NTC-200309 with current on schedule 6/1/2018 in-service
- Kiowa – North Loving – China Draw 345/115kV Project assigned in the High Priority Increment Load Study (HPILs) per SPP-NTC-200309 with current on schedule 6/1/2018 in-service
- Kiowa – Road Runner 345/230kV Project assigned in the High Priority Increment Load Study (HPILs) per SPP-NTC-200309 with current on schedule 6/1/2018 in-service
- Ochoa 115kV Reactive Power Support assigned in 2015 Integrated Transmission Plan Near Term Assessment (ITPNT) per SPP-NTC-C-200324
- Potash Junction 230kV Reactive Power Support assigned in 2015 Integrated Transmission Plan Near Term Assessment (ITPNT) per SPP-NTC-C-200324
- Road Runner 115kV Reactive Power Support assigned in 2015 Integrated Transmission Plan Near Term Assessment (ITPNT) per SPP-NTC-C-200324

Depending upon the status of higher or equally queued customers, the Interconnection Customer's in-service date is at risk of being delayed or their Interconnection Service is at risk of being reduced until the in-service date of these Other Network Upgrade(s).

Conclusion

The Affected System Interconnection Customer is responsible for \$16,000 of Affected System Transmission Owner Interconnection Facilities and Non-Shared Network Upgrade(s). The Affected System Interconnection Customer is responsible for \$159,022 of Shared Network Upgrade(s). After all Affected System Transmission Owner Interconnection Facilities, Non-Shared Network Upgrade(s), and Shared Network Upgrade(s) have been placed into service, Affected System Interconnection Service for 10.0 MW as requested by ASGI-2014-009 can be allowed for the Affected System. At this time the total allocation of costs assigned to ASGI-2014-009 for Affected System Interconnection Service are estimated at \$175,022.



**Facility Study For
Southwest Power Pool (SPP)**
10 MW Solar Farm
Eddy County, New Mexico
SPP # ASGI-2014-009

March 17, 2015

Transmission Planning South
Xcel Energy Services

Executive Summary

("Interconnection Customer") in 2015 requested the interconnection of a solar generation facility located in Eddy County, New Mexico to Wood Draw Substation on the 12.47 kV distribution network. Wood Draw Substation is served from SPS's 115 kV transmission line W-39, which is sourced out of Red Bluff Switching Station. This facility has a capacity of 10 MW. The Interconnection Customer's facility will connect to Wood Draw Substation located approximately 30 miles southeast of Carlsbad, New Mexico. The Interconnection Customer's desired commercial operation date is 12/1/2016. Southwestern Public Service Company (SPS) is a New Mexico Corporation and wholly owned subsidiary of Xcel Energy Inc. SPS is an affected system utility under Southwest Power Pool's (SPP) OATT, and the costs shown in table 1 will be included in the Affected Systems Interconnection Agreement between Interconnection Customer, SPP, and SPS.

SPP originally evaluated the request to interconnect the generator facility to the Wood Draw distribution system in a Definitive Interconnection System Impact Study (DISIS)-2014-002 for ASGI-2014-009, which was completed in January 2015. The interconnection request was studied using Solar PV inverter for a total of 10 MW.

SPP requires that each generator shall implement Automatic Under Frequency Load Shedding (UFLS) according to the SPP UFLS Plan at the following link: http://www.spp.org/publications/SPP%20UFLS%20Plan_Final.pdf. To fulfill this requirement, coordination with Xcel Energy is required during the under-frequency relay-setting phase for the generation. The Interconnection Customer is required to report their generation off-nominal frequency tripping relay settings to SPP and SPS. SPS specifies that generators shall not trip at frequencies above 58.5 Hz unless exceptions in the Transmission Provider Criteria are met. The Interconnection Customer agrees that the energy generating units installed at this interconnection will not be tripped for under-frequency conditions above 58.5 Hz in compliance with Transmission Provider criteria. This means that the generation subject to this Interconnection Agreement may not trip for under-frequency conditions on the transmission system until all under-frequency load shedding relays have operated. SPS will also require that the Interconnection Customer be in compliance with all applicable criteria, guidelines, standards, requirements, regulations, and procedures issued by the North American Electric Reliability Corporation (NERC), SPP, and the Federal Energy Regulatory Commission (FERC) or their successor organizations.

The Interconnection Customer is responsible for the cost of the Interconnection Facilities, as designated in their interconnection agreement with the owner of the host distribution system.

General Description of SPS Facilities ¹

1. **Existing Line Terminal:** See Appendix A, Figure A-1, for one-line diagram.
 - 1.1. **Location:** Interconnection Customer will construct their generation facility and connect their 12.47 kV distribution system to SPS's 12.47 kV distribution system at Wood Draw Substation. Appendix A shows a one-line diagram of Wood Draw Substation and the approximate location of the Point of Interconnection (POI) of the Interconnection Customer.
 - 1.2. **Relay and Protection Scheme:** There are no 115 kV transmission relay upgrades required for this solar generation addition.
 - 1.3. **Revenue Metering:** SPS's 115 kV circuit W-39 serves Wood Draw Substation with a 115/13.2 kV 20 MVA transformer, which is connected to the Interconnection Customer's solar energy facility. An individual billing meter will be installed per ANSI C12.1 accuracy class 0.2 (3-PT's IEEE C57.13 accuracy class 0.3 and 3 CT's IEEE C57.13 accuracy class 0.15) for full 3-phase 4-wire metering. Pulses out of the billing meter will be sent via SCADA to the Transmission Owner's Control Center in Amarillo, Texas.
 - 1.4. **SCADA Real Time Monitoring:** Real Time Data (MW, MVA_r output plus hourly accumulator data) will be provided to the SPS System Control Center for monitoring by SPS and SPP. The direct cost will be charged to the Interconnection Customer.

¹ All modifications to SPS facilities will be owned, maintained and operated by SPS.

- 1.5. **Communications:** To meet its communications obligations, the Interconnection Customer or its Host Distribution Provider system shall be responsible for making arrangements with appropriate communications providers to provide SCADA and accumulator data to the SPS Control Center.

The following communications schematic diagram, which includes communication equipment information for the Interconnection Customer, SPP, SPS, and Host Distribution Provider, is provided to assist the Parties.

A schematic outlining the proposed communications is provided below.

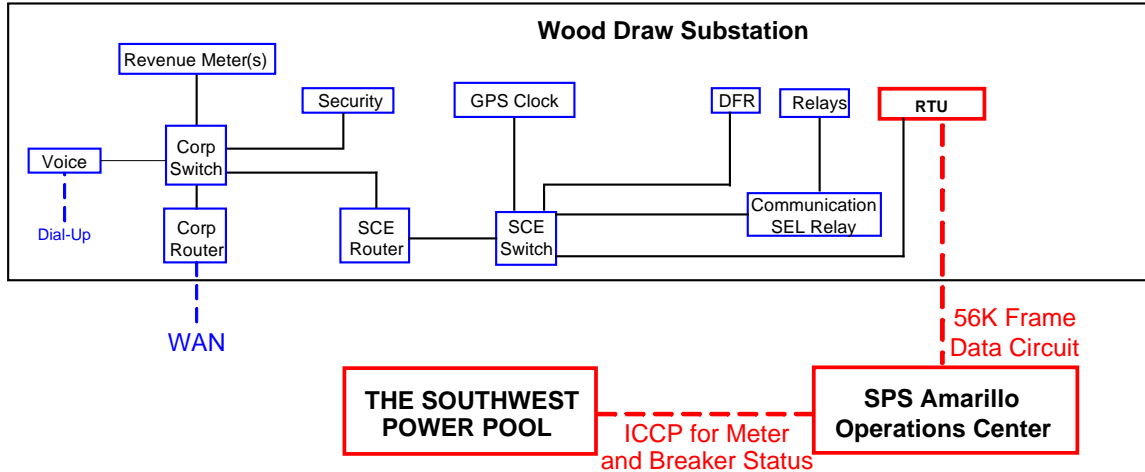

2. **Project and Operating Concerns:**

- 2.1 Close work between SPS personnel, the Interconnection Customer’s personnel, and Host Distribution Provider will be imperative in order to meet any in-service date that has been established.

3. **Fault Current Study:** The available fault current at the Wood Draw Substation on the 115 kV is shown in Table below.

Short Circuit Current Availability at Wood Draw Sub without contribution from ASGI 2014-009				
Fault Location	Fault Current (Amps)		Impedance (Ω)	
	Line-to-Ground	3-Phase	Z^+	Z^0
115 kV Bus	1,416	2,546	9.48+j23.87	26.14+j83.37

4. Estimated Construction Costs

The projects required for the interconnection of this Solar Energy Facility are summarized in the table below.

Table 1, Required Interconnection Projects²

Project	Description	Estimated Cost
	Shared Network Upgrades	
	Transmission Owner Interconnection Facilities (at the Interconnection Customer's expense)	
2	Communications ³	\$ See footnote
3	Revenue metering	\$ 16,000
	Subtotal:	\$ 16,000
	Total Cost	\$ 16,000

This table does not include any SPS distribution interconnection costs.

Engineering and Construction:

An engineering and construction schedule for the installation of the SCADA monitoring equipment and software changes in the SPS Control Center is estimated at 12 months. No schedule can be provided at this time for the shared network upgrades. Other factors associated with clearances, equipment delays and work schedules could cause additional delays. The schedule is applicable after all required agreements are signed and internal approvals are granted.

All additional cost for work not identified in this study is the sole responsibility of the Interconnection Customer unless other arrangements are made.

² The cost estimates are 2015 dollars with an accuracy level of $\pm 20\%$.

³ It is the Requester's responsibility to provide both the data circuit and both dial-up telephone circuits, see Section 1.5.

Appendix A

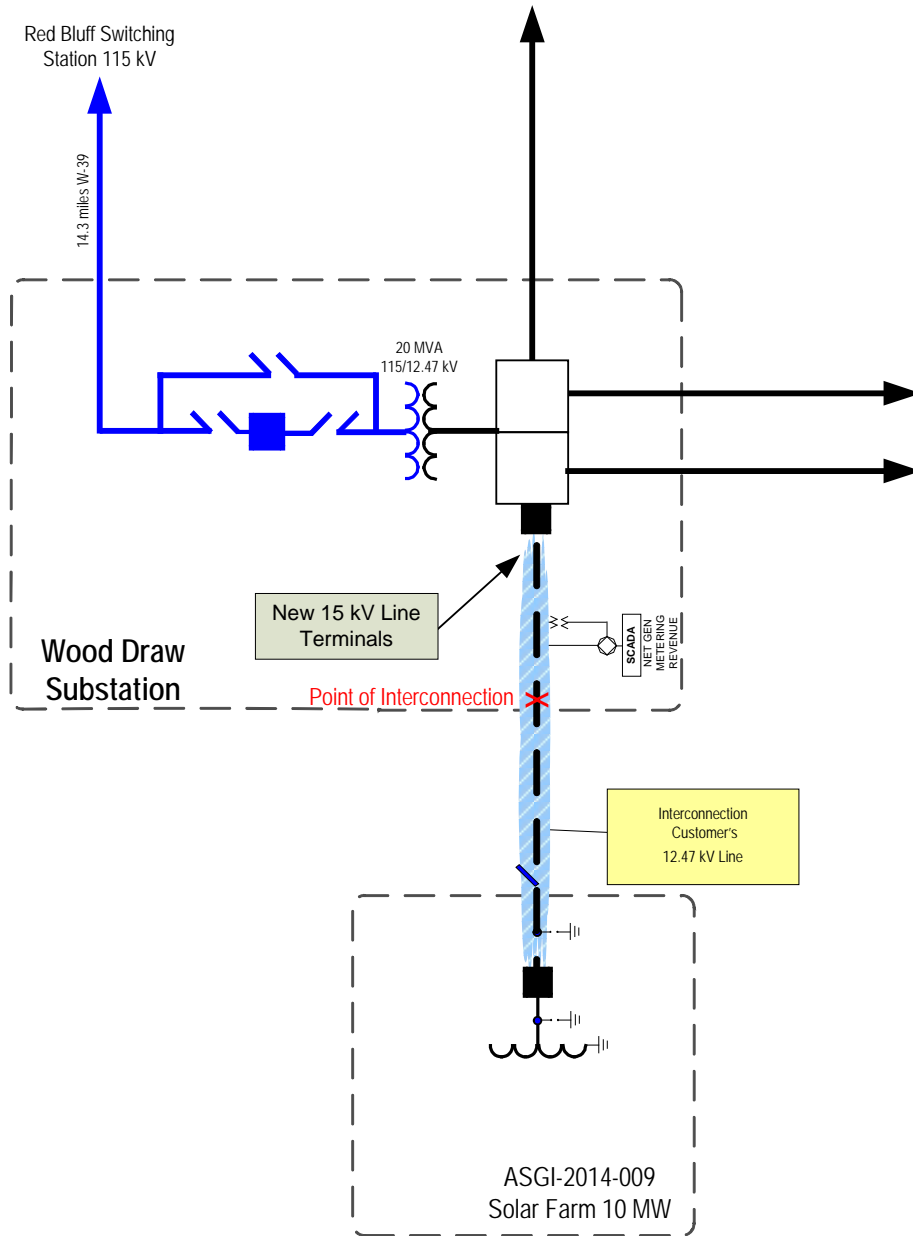

Figure 1 - One-line diagram of Wood Substation

END OF REPORT –