



# Affected System Interconnection Facilities Study

**ASGI-2014-002**

**January 2016**

**Generator Interconnection**



---

## Revision History

---

| Date      | Author | Change Description  |
|-----------|--------|---|
| 1/11/2016 | SPP    | Final Affected System Interconnection Facilities Study Report Revision 0 Issued |

# Table of Contents

**Revision History** ..... **ii**

**Table of Contents**..... **iii**

**Affected System Interconnection Facilities Study Summary** ..... **1**

    Affected System Interconnection Facilities Study Introduction .....1

    Phase(s) of Interconnection Service.....1

    Affected System Interconnection Customer Interconnection Facilities .....1

    Affected System Transmission Owner Interconnection Facilities and Non-Shared Network Upgrade(s).....2

    Shared Network Upgrade(s).....3

    Affected System Other Network Upgrade(s) .....3

    Conclusion .....4

**Appendices** ..... **5**

    A : SPS Affected System Transmission Owner Interconnection Facilities Study Report .....A-0

---

# Affected System Interconnection Facilities Study Summary

---

## **Affected System Interconnection Facilities Study Introduction**

This Affected System Interconnection Facilities Study for ASGI-2014-002 (Affected System Interconnection Request) is for a 49.6 MW solar farm facility located in Guadalupe County, New Mexico. The Affected System Interconnection Request is proposing to Interconnection to the Farmers Electric Cooperative, Inc. (FEC). The Affected System Interconnection Request was studied in the DISIS-2014-002 Impact Study, DISIS-2014-002-1 Impact Restudy, DISIS-2014-002-2 Impact Restudy, and DISIS-2014-002-4 Impact Restudy as an Energy Resource Interconnection Service (ERIS) only request. In DISIS-2014-002-3 Impact Restudy, the Affected System Interconnection Customer was provided updated cost allocation. Since the posting of the DISIS-2014-002 Impact Study the Affected System Interconnection Customer has executed the Affected System Interconnection Facilities Study Agreement to proceed to the Interconnection Facilities Study. The request for interconnection was placed with SPP by the requesting customer (Affected System Interconnection Customer) in accordance with Southwest Power Pool (SPP) Open Access Transmission Tariff (OATT), which covers new generation interconnections on SPP's transmission system.

Southwestern Public Service Company (SPS), an operating company subsidiary of Xcel Energy Inc., performed a detailed Affected System Interconnection Facilities Study at the request of SPP for the Affected System Interconnection Request. Affected System Interconnection Customer's original in service date for the Affected System Interconnection Request is December 16, 2016. SPP has proposed the full Interconnection Service will be available after the assigned Transmission Owner Interconnection Facilities and Non-Shared Network Upgrade(s) are completed. Full interconnection service will require Network Upgrade(s) listed in the "Other Network Upgrade(s)" section.

The primary objective of the Interconnection Facilities Study (IFS) is to identify necessary Transmission Owner Interconnection Facilities, network upgrade(s), other direct assigned upgrade(s), and associated upgrade lead times needed for the additional of the requested Interconnection Service into the SPP Transmission System at the specific Point of Interconnection (POI).

## **Phase(s) of Interconnection Service**

It is not expected that Interconnection Service will occur in phases. However, Interconnection Service will not be available until all Interconnection Facilities and Network Upgrade(s) can be placed in service.

## **Affected System Interconnection Customer Interconnection Facilities**

The Interconnection Request's Generation Facility is currently proposed to consist of thirty-one (31) pairs (2) of 0.8 MW SMA Sunny Central 800CP Solar Inverters for a total generating nameplate of 49.60 MW. The 34.5kV collector system for this solar farm is planned to be connect to one (1) 115/34.5kV Affected System Interconnection Customer owned and maintained transformer at the Affected Study Interconnection Customer owned substation. A one (1) mile overhead 115kV transmission circuit will connect the Generating Facility from the Interconnection Customer owned

substation to the Point of Interconnection (POI) at a new FEC owned and maintained 115kV bus at a new FEC substation tapping the existing Santa Rosa – Tukumcari 69kV circuit. The approximate location for this new substation is forty-four (44) miles from Tukumcari on the Santa Rosa – Tukumcari transmission circuit. The Santa Rosa – Tukumcari 69kV to 115kV voltage conversion is currently an assigned FEC Network Upgrade to this Affected System Interconnection Customer.

### **Affected System Transmission Owner Interconnection Facilities and Non-Shared Network Upgrade(s)**

In addition to the FEC Interconnection Facilities and Network Upgrades for the Santa Rosa – Tukumcari 69kV transmission circuit and associated substation(s) to 115kV voltage convention, FEC also will require a new FEC-Tukumcari 115kV 3 breaker ring bus.

To facilitate Affected System Interconnection, the Affected System Transmission Owner, SPS, the, will need to install fiber optics from Lopez to FEC-Tukumcari and from FE-Tukumcari to Norton, upgrade revenue metering, and replace relays at Lopez and Norton for the acceptance of the Affected System Interconnection Customer’s Interconnection Facilities. Currently, SPS estimates an Engineering and Construction (E&C) lead time of approximately thirty (30) months after a fully executed Affected System’s Facilities Construction Agreement (ASFCA) for the completion of Transmission Owner Interconnection Facilities and Non-Shared Network Upgrades. This E&C lead time is anticipated to be simultaneously completed with the construction time for FEC-Tukumcari 115kV 3 breaker ring bus.

The Affected System Interconnection Customer or Host Distribution Provider shall be responsible to provide Supervisory Control and Data Acquisition (SCADA) and accumulator data to the SPS Control Center. A diagram intended to assist the Affected System Interconnection Customer can be found in the Xcel Affected System Interconnection Facilities System Report in **Section 1.5**.

At this time, Affected System Interconnection Customer is responsible for \$52,226,405 of SPS Affected System Transmission Owner Interconnection Facilities (AFTOIF) and Affected System Non-Shared Network Upgrade(s). **Table 1** displays the estimated costs for AFTOIF and Affected System Non-Shared Network Upgrade(s).

**Table 1: Affected System Interconnection Customer TOIF and Non-Shared Network Upgrade(s)**

| TOIF and Non-Shared Network Upgrades Description  | Allocated Cost (\$) | Allocated Percent (%) | Total Cost (\$)     |
|---|---------------------|-----------------------|---------------------|
| <b><u>SPS Affected System Interconnection Substation - Non-Shared Network Upgrades</u></b> 115kV Substation work fiber optic FEC-Tukumcari to Lopez, fiber optic FEC-Tukumcari to Norton, Revenue Metering Upgrades, and relays at Lopez and Norton | \$2,633,904         | 100%                  | \$2,633,904         |
| <b><u>SPS Norton – Pleasant Hill 230kV Circuit #1 Non-Shared Network Upgrade(s)</u></b> Build approximately sixty (60) miles of new 230kV line from Norton – Pleasant Hill.   | \$49,592,501        | 100%                  | 49,592,501          |
| <b>Total</b>  | <b>\$52,226,405</b> | <b>100%</b>           | <b>\$52,226,405</b> |

The separately posted Interconnection Facilities Study for the Pleasant Hill Upgrade can be found at this link:

[http://sppoasis.spp.org/documents/swpp/transmission/studies/files/2014\\_Generation\\_Studies/IFS-2014-002\\_SPS-SharedNetworkUpgrades\\_FacilityStudy-R1.pdf](http://sppoasis.spp.org/documents/swpp/transmission/studies/files/2014_Generation_Studies/IFS-2014-002_SPS-SharedNetworkUpgrades_FacilityStudy-R1.pdf)

### Shared Network Upgrade(s)

The Affected System Interconnection Request was studied in the DISIS-2014-002 Impact Study, DISIS-2014-002-1 Impact Restudy, DISIS-2014-002-2 Impact Restudy, and DISIS-2014-002-4 Impact Restudy as an Energy Resource Interconnection Service (ERIS) only request. In DISIS-2014-002-3 Impact Restudy, the Affected System Interconnection Customer was provided updated cost allocation. At this time, the Affected System Interconnection Customer is allocated \$2,977,542 for Shared Network Upgrades. If higher queued Interconnection Request(s) withdraw from the queue, suspend or terminate their GIA, restudies will have to be conducted to determine the Affected System Interconnection Customers' allocation of Shared Network Upgrades. All studies have been conducted on the basis of higher queued Interconnection Request(s) and the Network Upgrade(s) associated with those higher queued Interconnection Requests being placed in service. At this time, the Interconnection Customer is allocated the following cost listed in **Table 2** for Shared Network Upgrade.

**Table 2: Affected System Interconnection Customer Shared Network Upgrades**

| Shared Network Upgrades Description  | Allocated Cost (\$) | Allocated Percent (%) | Total Cost (\$) |
|--|---------------------|-----------------------|-----------------|
| <b>Tolk – Plant X 230kV Circuit #1 &amp; #2:</b> Rebuild Tolk – Plant X circuits #1 and #2   | \$1,162,320         | 11.71                 | \$9,921,693     |
| <b>TUCO 2 Substation (Crawfish Draw) and 345/230kV Transformer:</b> Build new 345/230kV substation and transformer approximately 4 miles from TUCO substation. Tap and re-terminate TUCO – Border 345kV and TUCO – Swisher into new station. | \$1,815,222         | 7.33                  | \$24,764,205    |
| Total  | \$2,977,542         | 8.58                  | \$34,685,898    |

The separately posted Interconnection Facilities Study for the Shared Network Upgrades can be found at this link:

[http://sppoasis.spp.org/documents/swpp/transmission/studies/files/2014\\_Generation\\_Studies/IFS-2014-002\\_SPS-SharedNetworkUpgrades\\_FacilityStudy-R1.pdf](http://sppoasis.spp.org/documents/swpp/transmission/studies/files/2014_Generation_Studies/IFS-2014-002_SPS-SharedNetworkUpgrades_FacilityStudy-R1.pdf)

### Affected System Other Network Upgrade(s)

Certain Other Network Upgrades are currently not the cost responsibility of the Interconnection Customer but will be required for full Interconnection Service.

- 1) China Draw 115kV Reactive Power Support build assigned in 2015 Integrated Transmission Plan Near Term Assessment (ITPNT) per SPP-NTC-C-200324
- 2) Hobbs Interchange - Kiowa 345kV Transmission circuit #1 assigned in the High Priority Increment Load Study (HPILs) per SPP-NTC-200309 with current on schedule 6/1/2018 in-service
- 3) Kiowa – North Loving – China Draw 345/115kV Project assigned in the High Priority Increment Load Study (HPILs) per SPP-NTC-200309 with current on schedule 6/1/2018 in-service
- 4) Kiowa – Road Runner 345/230kV Project assigned in the High Priority Increment Load Study (HPILs) per SPP-NTC-200309 with current on schedule 6/1/2018 in-service
- 5) Potash Junction 230kV Reactive Power Support assigned in 2015 Integrated Transmission Plan Near Term Assessment (ITPNT) per SPP-NTC-C-200324
- 6) Road Runner 115kV Reactive Power Support assigned in 2015 Integrated Transmission Plan Near Term Assessment (ITPNT) per SPP-NTC-C-200324

Depending upon the status of higher or equally queued customers, the Affected System Interconnection Request's in-service date is at risk of being delayed or their Affected System Interconnection Service is at risk of being reduced until the in-service date of these Other Network Upgrades.

### **Conclusion**

Interconnection Service for the Affected System Interconnection Request will be delayed until the Affected System Transmission Owner Interconnection Facilities and Non-Shared Network Upgrades are constructed. The Affected System Interconnection Customer is responsible for \$52,226,405 of Affected System Transmission Owner Interconnection Facilities and Non-Shared Network Upgrades. At this time, the Affected System Interconnection Customer is allocated \$2,977,542 for Shared Network Upgrades. After all Interconnection Facilities and Network Upgrades have been placed into service, Interconnection Service for 49.60 MW, as requested by the Affected System Interconnection Customer can be allowed.

At this time the total allocation of costs assigned to Affected System Interconnection Customer for interconnection Service are estimated at \$55,203,947.

---

# Appendices

---



## **A: SPS Affected System Transmission Owner Interconnection Facilities Study Report**

See next page for SPS Affected System Interconnection Facilities Study Report.



**Facility Study For  
Southwest Power Pool (SPP)**  
49.6 MW Solar Farm at Santa Rosa  
Farmers Electric Cooperative  
Guadalupe County, New Mexico  
SPP # ASGI-2014-002

December 14, 2015

Transmission Planning South  
Xcel Energy Services

## Executive Summary

Interconnection Customer (IC), in 2015 requested the interconnection of solar generation facility located in Guadalupe County, New Mexico to Farmers Electric Cooperative, Inc. (FEC) new 115 kV network. FEC is served from Southwestern Public Service's (SPS) 115 kV W-58 transmission line, which runs between SPS Norton and Lopez Substations. This generator facility has a capacity of 49.6 MW. The Interconnection Customer's Facility will be located near FEC Santa Rosa Substation (approximately 44 miles west of FEC Interchange (Tucumcari). The Interconnection Customer's desired commercial operation date is 12/15/2016.

The Southwest Power Pool (SPP) originally evaluated the request to interconnect the generator facilities to FEC's 115 kV system in Definitive Interconnection System Impact Study (DISIS)-2014-002, which was completed in January 2015.

SPP requires that each generator shall implement Automatic Under Frequency Load Shedding (UFLS) according to the SPP UFLS Plan at the following link: [http://www.xcelenergy.com/Energy\\_Partners/Generation\\_Owners/Interconnections\\_for\\_Transmission](http://www.xcelenergy.com/Energy_Partners/Generation_Owners/Interconnections_for_Transmission). To fulfill this requirement, coordination with Xcel Energy is required during the under-frequency relay-setting phase for the generation. The Interconnection Customer is required to report their generation off-nominal frequency tripping relay settings to SPP and SPS. SPP specifies that generators shall not trip at frequencies above 58.5 Hz unless exceptions in the Transmission Provider Criteria are met. The Interconnection Customer agrees that the energy generating units installed at this interconnection will not be tripped for under-frequency conditions above 58.5 Hz in compliance with Transmission Provider criteria. This means that the generation subject to this Interconnection Agreement may not trip for under-frequency conditions on the transmission system until all under-frequency load shedding relays have operated. SPS will also require that the Interconnection Customer be in compliance with all applicable criteria, guidelines, standards, requirements, regulations, and procedures issued by the North American Electric Reliability Corporation (NERC), SPP, and the Federal Energy Regulatory Commission (FERC) or their successor organizations.

This facilities study addresses the requirements that the interconnection customer must meet before interconnecting on the third party transmission or distribution system in order to provide the appropriate information to the SPS/SPP transmission operator for reliability and operating purposes. This will require SPS to install All Dielectric Self Supporting (ADSS) Fiber Optics, on SPS' W58 transmission line, from Lopez to FEC-Tucumcari and FEC-Tucumcari to Norton substation.

This study may require upgrades to communications equipment, data monitoring equipment, transmission element protective equipment, and may also reflect any allocation of shared network upgrades as determined by SPP.

This facility study does not address any data requirements, communications requirements, or any other requirements for registration or operation in the SPP energy market. Those requirements are the sole responsibility of the generation developer and/or their energy purchaser.

The shared network upgrades will be determined by SPP and may impact the overall costs for interconnection to the Interconnection Customer.

As for this request (ASGI-2014-002), Farmers Electric Cooperative will construct a new 3-breaker ring substation to replace their FEC Tucumcari substation. It is anticipated that the entire process for FEC to complete the new 115 kV 3-breaker ring substation and for SPS to install the ADSS Fiber Optics is approximately 30 months after an Interconnection Agreement is signed, payment and an authorization to proceed is received by SPS.

The costs of the SPS upgrades are shown below in Table 1, with the detailed description of the cost shown in Table 3.

**Table 1, Cost Summary<sup>1</sup>**

|                                |  |           |                  |
|--------------------------------|--|-----------|------------------|
| <b>Shared Network Upgrades</b> |  | <b>\$</b> | <b>TBD</b>       |
|                                | Network Upgrades:                              | <b>\$</b> | <b>2,373,904</b> |
|                                | Transmission Owner Interconnection Facilities: | <b>\$</b> | <b>260,000</b>   |
|                                | <b>Total:</b>                                  | <b>\$</b> | <b>2,633,904</b> |

<sup>1</sup> The cost estimates are 2015 dollars with an accuracy level of  $\pm 20\%$ .

## General Description of SPS<sup>2</sup> Facilities

### 1. Metering Facilities:

- 1.1. **Relay and Protection Scheme:** The new 115 kV breaker line terminal primary protection serving the interconnection customer 115 kV transmission line will use line current differential relaying over optical fiber installed in the under strung position on SPS's 115 kV transmission line from Lopez to FEC-Tucumcari to Norton. Secondary relaying will use mirrored bit, Permissive Overreaching Transfer Trip (POTT) over the optical fiber. An SEL 411L and an SEL 311C will be used as primary and secondary relays. A SEL 351S will be used for line/bus SCADA closing conditions for the 115 kV breakers and for breaker failure. Relay modifications at Lopez Substation and Norton Switching Station may be required. Farmers' will need to coordinate relay installation with SPS for the fiber optic between their substation, Norton and Lopez.

An SEL 421 will display the bus voltage, GCB amps, MW, MVAR, and fault location. A communication relay will be installed and for other functions as required.

- 1.2. **Revenue Metering:** An individual billing meter will be installed at the new FEC 3-breaker ring Substation on both the 115 kV line terminals to FEC's IC and FEC Clovis, which meets the standards: ANSI C12.1 accuracy class 0.2 (3-PT's IEEE C57.13 accuracy class 0.3 and 3-CT's IEEE C57.13 accuracy class 0.15) for full 3-phase 4-wire metering. The meter will be bi-directional. There will be one meter per line terminal. Each will have full 4 quadrant metering. Pulses out of the billing meter will be sent to SPP via an ICCP link, which will then be forward to the Transmission Owner's Control Center in Amarillo, Texas via their ICCP link.
- 1.3. **Disturbance Monitoring Device:** A Disturbance Fault Recorder (DFR), capable of recording faults, swings, and long term trending, will be installed by FEC to monitor and record conditions in the substation and on the transmission lines. The disturbance equipment shall also be equipped with a GPS time synching clock. This equipment will have communication capability with a dedicated communication circuit. The disturbance equipment will have its own dedicated communications circuit.
- 1.4. **Remote Terminal Unit (RTU):** A new RTU will be utilized with communications for the new Substation. A Communication SEL Relay will be installed for relay communications and other functions as required. FEC will provide and install an RTU for metering and telemetry at their new 3-breaker ring substation. The direct cost will be charged to the Interconnection Customer.

---

<sup>2</sup> All modifications to SPS facilities will be owned, maintained and operated by SPS.

**1.5. Communications:** To meet its Communications obligations, the Interconnection Customer shall be responsible for making arrangements with the local phone company to provide a communication circuit as required by the Transmission Owner. Transmission Owner equipment may include, but is not limited to the following: relay communication equipment, RTU, and disturbance monitoring equipment at FEC-Tucumcari Substation. Prior to any construction, the Interconnection Customer is required to contact the Transmission Owner substation-engineering department for all communication details and provide detail of the method to be used in communication.

The following communications schematic diagram, which includes communication equipment information for the Interconnection Customer, Transmission Provider (Southwest Power Pool) and Transmission Owner (Southwestern Public Service), is provided to assist the Parties as a template.

A schematic outlining the proposed communications is provided below.

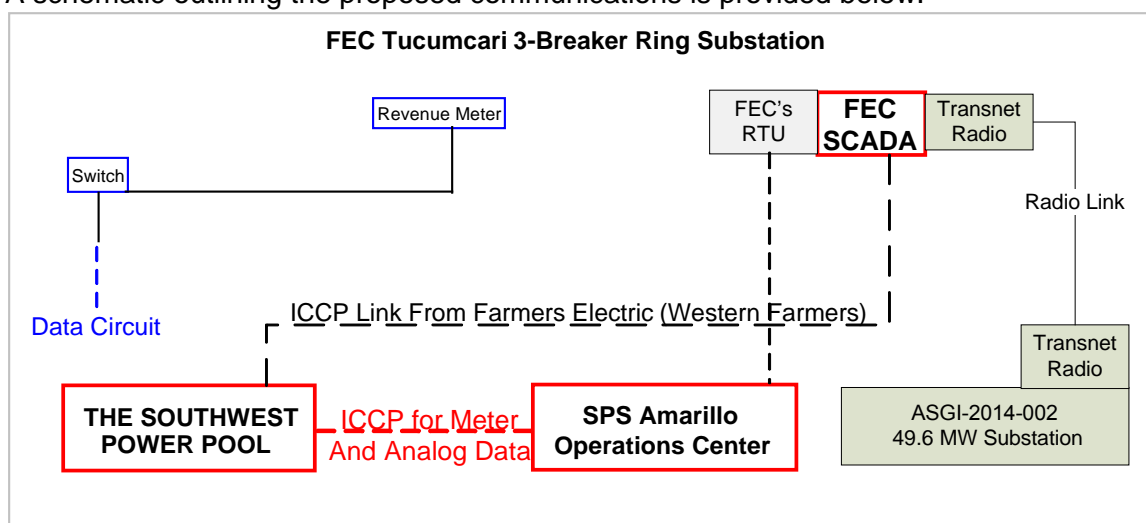

Interconnection Customer shall be responsible for cost to provide fiber optic communication circuit installed on the transmission line from Lopez to FEC Tucumcari and from FEC-Tucumcari to Norton for protective relaying and for transmitting metering and status data to SPS.

**2. Fault Current Study:** The available fault current at the FEC Tucumcari Interchange on the 115 kV is shown in the Table below.

| <b>Short Circuit Current Availability at FEC Tucumcari Interchange without contribution from ASGI 2012-002</b> |                      |         |                        |             |
|--|----------------------|---------|------------------------|-------------|
| Without the Quay Generation, but with Caprock Wind in service 18 MW.   |                      |         |                        |             |
| Fault Location   | Fault Current (Amps) |         | Impedance ( $\Omega$ ) |             |
|  | Line-to-Ground       | 3-Phase | $Z^+$                  | $Z^0$       |
| 115 kV Bus   | 2,244                | 2,044   | 8.99+j31.52            | 4.09+j23.76 |

| <b>Short Circuit Current Availability at FEC Tucumcari Interchange without contribution from ASGI 2012-002</b> |                      |         |                        |             |
|--|----------------------|---------|------------------------|-------------|
| With the Quay Generation in service 23 MW and with Caprock Wind in service 18 MW.                              |                      |         |                        |             |
| Fault Location   | Fault Current (Amps) |         | Impedance ( $\Omega$ ) |             |
|  | Line-to-Ground       | 3-Phase | $Z^+$                  | $Z^0$       |
| 115 kV Bus   | 2,740                | 2,714   | 5.30+j24.15            | 4.09+j23.76 |

### 3. Estimated Construction Costs

3.1 The projects required for the interconnection of this Solar Farm which is 49.6 MW of solar panels are summarized in the table below for ASGI-2014-002.

**Table 2, Required Interconnection Projects<sup>3</sup>**

| Project            | Description   | Estimate            |
|--------------------|---|---------------------|
|                    | <b>Shared Network Upgrades:</b>   |                     |
| 1                  |   | \$ TBD              |
|                    | <b>Subtotal:</b>  | <b>\$ TBD</b>       |
|                    | <b>SPS Transmission Network Upgrades:</b>   |                     |
| 2                  | Install Fiber Optics from Lopez to FEC Tukumcari and from FEC-Tukumcari to Norton on the 115 kV in the under strung position. | \$ 1,130,682        |
| 3                  | Replace relays at Lopez   | \$ 309,427          |
| 4                  | Replace relays at Norton  | \$ 933,795          |
|                    | <b>Subtotal:</b>  | <b>\$ 2,373,904</b> |
|                    | <b>Interconnection Facilities (Interconnection Customer's Expense)</b>  |                     |
| 5                  | SCADA data to SPS Control Center <sup>4</sup>   | \$ See footnote     |
| 6                  | Revenue metering upgrades   | \$ 260,000          |
|                    | <b>Subtotal:</b>  | <b>\$ 260,000</b>   |
| <b>Total Cost:</b> |   | <b>\$ 2,633,904</b> |

### 4. Engineering and Construction:

4.1 An engineering and construction schedule for this project will be determined by the interconnection customer's time schedule to install their communication equipment by what means/method the information will be provided for transmitting metering and status data to SPS and SPP from the IC's Solar Farm (Farmer's Electric customer). Other factors associated with clearances, equipment delays and work schedules could cause additional delays. The schedule is applicable after all required agreements are signed and internal approvals are granted.

All additional cost for work not identified in this study is the sole responsibility of the Interconnection Customer or FEC unless other arrangements are made.

<sup>3</sup> The cost estimates are 2015 dollars with an accuracy level of  $\pm 20\%$  except it does not include AFUDC.

<sup>4</sup> It is the Requester's responsibility to provide the data circuit.



## Appendix A

PLAN A

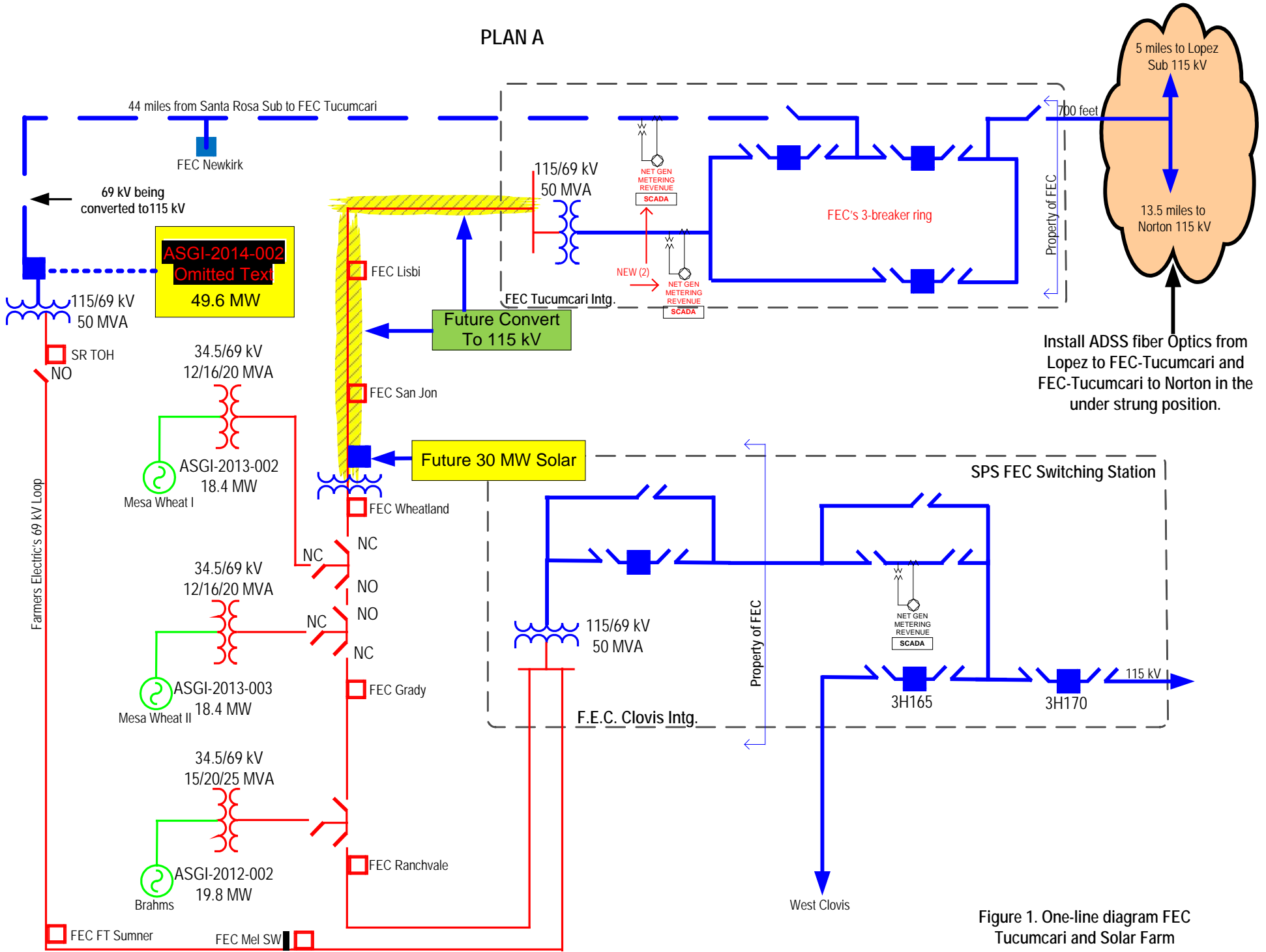

Figure 1. One-line diagram FEC Tucumcari and Solar Farm

*END OF REPORT –*