



Definitive Interconnection System Impact Study for Generation Interconnection Requests (DISIS-2010-002-2)

November 2011

Generation Interconnection



Revision History

Date or Version Number	Author	Change Description	Comments
1/31/2011	Southwest Power Pool	N/A	Report Issued
7/26/2011	Southwest Power Pool	Account for Withdrawn Projects	Report Posted
11/08/2011	Southwest Power Pool	Account for Withdrawn Projects	Report Posted

Executive Summary

Generation Interconnection customers have requested a Definitive Interconnection System Impact Study (DISIS) under the Generation Interconnection Procedures (GIP) in the Southwest Power Pool Open Access Transmission Tariff (OATT). The Interconnection Customers' requests have been clustered together for the following Impact Cluster Study. This Impact Study analyzes the interconnecting of multiple generation interconnection requests associated with new generation totaling approximately 2,262 MW of new generation which would be located within the transmission systems of Midwest Energy Inc. (MIDW), Mid-Kansas Electric Power LLC (MKEC), Missouri Public Service (MIPU), Nebraska Public Power District (NPPD), Oklahoma Gas and Electric (OKGE), Omaha Public Power District (OPPD), Southwestern Public Service (SPS), Sunflower Electric Power Corporation (SUNC), Westar Energy (WERE) and Western Farmers Electric Cooperative (WFEC). The various generation interconnection requests have differing proposed in-service dates¹. The generation interconnection requests included in this Impact Cluster Study are listed in Appendix A by their queue number, amount, requested interconnection service, area, requested interconnection point, proposed interconnection point, and the requested in-service date. This restudy was performed to account for withdrawals within the DISIS-2010-001 study as well as higher queued projects withdrawing.

Power flow analysis has indicated that for the power flow cases studied 2,262 MW of nameplate generation may be interconnected with transmission system reinforcements within the SPP transmission system. Dynamic Stability and power factor analysis has determined the need for reactive compensation in accordance with Order No. 661-A for wind farm interconnection requests and those requirements are listed for each interconnection request within the contents of this report.

Dynamic Stability Analysis has determined that the transmission system will remain stable with the assigned Network Upgrades and necessary reactive compensation requirements.

The total estimated minimum cost for interconnecting the DISIS-2010-002 interconnection customers is \$261,000,000. These costs are shown in Appendix E and F. Interconnection Service to DISIS-2010-002 interconnection customers is also contingent upon higher queued customers paying for certain required network upgrades. The in service date for the DISIS customers will be deferred until the construction of these network upgrades can be completed.

These costs do not include the Interconnection Customer Interconnection Facilities as defined by the SPP Open Access Transmission Tariff (OATT). This cost does not include additional network constraints in the SPP transmission systems that were identified as shown in Appendix H.

Network Constraints listed in Appendix H are in the local area of the new generation when this generation is injected throughout the SPP footprint for the Energy Resource (ER) Interconnection Request. Certain Interconnection Requests were studied for Network Resource Interconnection Service (NR). Those constraints are listed in Appendix H. Additional Network constraints will have to be verified with a Transmission Service Request (TSR) and associated studies. With a defined source and sink in a TSR, this list of Network Constraints will be refined and expanded to account for all Network Upgrade requirements.

¹ The generation interconnection requests in-service dates will need to be deferred based on the required lead time for the Network Upgrades necessary. The Interconnection Customer's that proceed to the Facility Study will be provided a new in-service date based on the competition of the Facility Study.

The required interconnection costs listed in Appendix E and F do not include all costs associated with the deliverability of the energy to final customers. These costs are determined by separate studies if the Customer submits a Transmission Service Request through SPP's Open Access Same Time Information System (OASIS) as required by Attachment Z1 of the SPP OATT.

Table of Contents

Executive Summary	2
Table of Contents	4
Introduction	5
Model Development	5
Identification of Network Constraints	8
Determination of Cost Allocated Network Upgrades	9
Interconnection Facilities	10
Power flow	10
Stability Analysis	13
Conclusion	15
Appendix	16
A: Generation Interconnection Requests Considered for Impact Study	17
B: Prior Queued Interconnection Requests	18
C: Study Groupings	21
D: Proposed Point of Interconnection One line Diagrams.....	27
E: Cost Allocation per Interconnection Request (Including Prior Queued Upgrades).....	32
F: Cost Allocation per Proposed Study Network Upgrade	33
G: Power flow Analysis (Constraints for Mitigation)	34
H: Power flow Analysis (Constraints with greater than 3% TDF).....	35

Introduction

Pursuant to the Southwest Power Pool (SPP) Open Access Transmission Tariff (OATT), SPP has conducted this Definitive Interconnection System Impact Study (DISIS) for certain generation interconnection requests in the SPP Generation Interconnection Queue. These interconnection requests have been clustered together for the following Impact Study. The customers will be referred to in this study as the DISIS-2010-002 Interconnection Customers. This Impact Study analyzes the interconnecting of multiple generation interconnection requests associated with new generation totaling 2,262 MW of new generation which would be located within the transmission systems of Midwest Energy Inc. (MIDW), Mid-Kansas Electric Power LLC (MKEC), Missouri Public Service (MIPU), Nebraska Public Power District (NPPD), Oklahoma Gas and Electric (OKGE), Omaha Public Power District (OPPD), Southwestern Public Service (SPS), Sunflower Electric Power Corporation (SUNC), Westar Energy (WERE) and Western Farmers Electric Cooperative (WFEC). The various generation interconnection requests have differing proposed in-service dates². The generation interconnection requests included in this Impact Study are listed in Appendix A by their queue number, amount, requested interconnection service, area, requested interconnection point, proposed interconnection point, and the requested in-service date. This restudy was performed to account for withdrawals within the DISIS-2010-001 study as well as higher queued projects withdrawing.

The primary objective of this Definitive Interconnection System Impact Study is to identify the system constraints associated with connecting the generation to the area transmission system. The Impact and other subsequent Interconnection Studies are designed to identify attachment facilities, Network Upgrades and other Direct Assignment Facilities needed to accept power into the grid at each specific interconnection receipt point.

Model Development

Interconnection Requests Included in the Cluster

SPP has included all interconnection requests that submitted a Definitive Interconnection System Impact Study request no later than September 30, 2010 and were subsequently accepted by Southwest Power Pool under the terms of the Generator Interconnection Procedures (GIP) that became effective March 30, 2010.

Affected System Interconnection Requests - Also included in this Definitive Impact Study are three Affected System Studies, all of the requests are on the Lea County Electric Cooperative system in Lea County, New Mexico. The Affected System Studies have been given the designation ASGI-2010-020 (Tatum – Crossroads 69kV), ASGI-2010-021 (Saunders – Anderson 69kV), and ASGI-2011-001 (Lovington 115kV) respectively.

The interconnection requests that are included in this study are listed in Appendix A.

² The generation interconnection requests in-service dates will need to be deferred based on the required lead time for the Network Upgrades necessary. The Interconnection Customer's that proceed to the Facility Study will be provided a new in-service date based on the competition of the Facility Study.

Previous Queued Projects

The previous queued projects included in this study are listed in Appendix B. In addition to the Base Case Upgrades, the previous queued projects and associated upgrades were assumed to be in-service and added to the Base Case models. These projects were dispatched as Energy Resources with equal distribution across the SPP footprint.

Development of Base Cases

Power flow - The 2010 series Transmission Service Request (TSR) Models 2011 spring, 2012 summer and winter, and 2016 summer and winter scenario 0 peak cases were used for this study. After the cases were developed, each of the control areas' resources were then re-dispatched using current dispatch orders.

Stability – The 2010 series SPP Model Development Working Group (MDWG) Models 2011 winter and 2011 summer were used for this study.

Base Case Upgrades

The following facilities are part of the SPP Transmission Expansion Plan or the Balanced Portfolio or recently approved Priority Projects. These facilities have been approved or are in construction stages and were assumed to be in-service at the time of dispatch and added to the base case models. The DISIS-2010-002 Customers have not been assigned cost for the below listed projects. The DISIS-2010-002 Customers Generation Facilities in service dates may need to be delayed until the completion of the following upgrades. If for some reason, construction on these projects is discontinued, additional restudies will be needed to determine the interconnection needs of the DISIS customers.

- Hitchland 345/230/115kV upgrades to be built by SPS for 2010/2011 in-service³.
 - Hitchland – Moore County 230kV line
 - Hitchland – Perryton 230kV line
 - Hitchland – Texas County 115kV line
 - Hitchland – Hansford County 115kV line
 - Hitchland – Sherman County Tap 115kV line
- Valliant – Hugo – Sunnyside 345kV – assigned to Aggregate Study AG3-2006 Customers
- Wichita – Reno County – Summit 345kV to be built by WERE⁴.
- Rose Hill – Sooner 345kV to be built by WERE/OKGE.
- Knob Hill – Steele City 115kV to be built by NPPD/WERE.
- Balanced Portfolio Projects⁵:
 - Gracemont 345/138/13.2kV Autotransformer
 - Woodward– Tuco 345kV line
 - Iatan– Nashua 345kV line
 - Muskogee– Seminole 345kV line
 - Post Rock– Axtell 345kV line
 - Spearville– Post Rock 345kV line

³ Approved 230kV upgrades are based on SPP 2007 STEP. Upgrades may need to be re-evaluated in the system impact study.

⁴ Approved based on an order of the Kansas Corporation Commission issued in Docket no. 07-WSEE-715-MIS

⁵ Notice to Construct (NTC) issued June, 2009

- Tap Stillwell – Swissvale 345kV line at West Gardner
- Priority Projects⁶:
 - Hitchland - Woodward double circuit 345kV
 - Woodward – Medicine Lodge double circuit 345kV
 - Spearville – Comanche (Clark) double circuit 345kV
 - Comanche (Clark) – Medicine Lodge double circuit 345kV
 - Medicine Lodge – Wichita double circuit 345kV
 - Medicine Lodge 345/138kV autotransformer

Contingent Upgrades

The following facilities do not yet have approval. These facilities have been assigned to higher queued interconnection customers. These facilities have been included in the models for the DISIS-2010-002 study and are assumed to be in service. The DISIS-2010-002 Customers at this time do not have responsibility for these facilities but may later be assigned the cost of these facilities if higher queued customers terminate their GIA or withdraw from the interconnection queue. The DISIS-2010-002 Customer Generation Facilities in service dates may need to be delayed until the completion of the following upgrades.

- Finney – Holcomb 345kV Ckt #2 line assigned to GEN-2006-044 interconnection customer. This customer is currently in suspension⁷.
- Central Plains – Setab 115kV transmission line assigned to GEN-2007-013 interconnection customer.
- Spearville 345/115kV autotransformer #2 assigned to 1st Cluster Interconnection Customers
- Grassland 230/115kV autotransformer #2 assigned to 1st Cluster Interconnection Customers (100% to GEN-2008-016)
- Judson Large – North Judson Large – Spearville Ckt #2 assigned to DISIS-2009-001-1 Interconnection Customers (100% to GEN-2008-079)
- Hitchland – Wheeler (Border) single circuit 345kV assigned to DISIS-2010-001 Interconnection Customers
- Madison County 230/115kV autotransformer #1 assigned to DISIS-2010-001 Interconnection Customer
- Norfolk – Madison County Tap 115kV Ckt #1 assigned to DISIS-2010-001 Interconnection Customers

⁶ Notice to Construct (NTC) issued June, 2010. NTC for double circuit lines indicated that NTC may be revised at a later time to be built at a higher voltage.

⁷ Based on Facility Study Posting November 2008

- Washita – Gracemont 138kV Ckt #2 assigned to DISIS-2010-001 Interconnection Customers
- Post Rock 345/230kV autotransformer #2 assigned to DISIS-2010-001 Interconnection Customers
- GEN-2008-079 Tap – Spearville 115kV Ckt #1 assigned to DISIS-2010-001 Interconnection Customers

Potential Upgrades Not in the Base Case

Any potential upgrades that do not have a Notification to Construct (NTC) have not been included in the base case. These upgrades include any identified in the SPP Extra-High Voltage (EHV) overlay plan, or any other SPP planning study other than the upgrades listed above in the previous section.

Regional Groupings

The interconnection requests listed in Appendix A were grouped together in ten different regional groups based on geographical and electrical impacts. These groupings are shown in Appendix C.

To determine interconnection impacts, ten different dispatch variations of the spring base case models were developed to accommodate the regional groupings.

Power flow - For each group, the various wind generating plants were modeled at 80% nameplate of maximum generation. The wind generating plants in the other areas were modeled at 20% nameplate of maximum generation. This process created ten different scenarios with each group being studied at 80% nameplate rating. These projects were dispatched as Energy Resources with equal distribution across the SPP footprint. Certain projects that requested Network Resource Interconnection Service were dispatched in an additional analysis into the balancing authority of the interconnecting transmission owner. This method allowed for the identification of network constraints that were common to the regional groupings that could then in turn have the mitigating upgrade cost allocated throughout the entire cluster. Each interconnection request was also modeled separately at 100% nameplate for certain analyses.

Peaking units were not dispatched in the 2011 spring model. To study peaking units' impacts, the 2012 and 2016 summer peak model was chosen and peaking units were modeled at 100% of the nameplate rating and wind generating facilities were modeled at 10% of the nameplate rating. Each interconnection request was also modeled separately at 100% nameplate for certain analyses.

Identification of Network Constraints

The initial set of network constraints were found by using PTI MUST First Contingency Incremental Transfer Capability (FCITC) analysis on the entire cluster grouping dispatched at the various levels mentioned above. These constraints were then screened to determine if any of the generation interconnection requests had at least a 20% Distribution Factor (DF) upon the constraint. Constraints that measured at least a 20% DF from at least one interconnection request were considered for mitigation. Interconnection Requests that were being studied for Network Resource Interconnection Service were studied in the additional NRIS analysis to determine if any constraint had at least a 3% DF. If so, these constraints were considered for mitigation.

Determination of Cost Allocated Network Upgrades

Cost Allocated Network Upgrades of wind generation interconnection requests were determined using the 2011 spring model. Cost Allocated Network Upgrades of peaking units was determined using the 2016 summer peak model. Once a determination of the required Network Upgrades was made, a power flow model of the 2011 spring case was developed with all cost allocated Network Upgrades in-service. A MUST FCITC analysis was performed to determine the distribution factor with no contingency that each generation interconnection request had on each new upgrade. The impact each generation interconnection request had on each upgrade project was weighted by the size of each request. Finally the costs due by each request for a particular project were then determined by allocating the portion of each request's impact over the impact of all affecting requests.

For example, assume that there are three Generation Interconnection requests, X, Y, and Z that are responsible for the costs of Upgrade Project '1'. Given that their respective DF for the project have been determined, the cost allocation for Generation Interconnection request 'X' for Upgrade Project 1 is found by the following set of steps and formulas:

- Determine an Impact Factor on a given project for all responsible GI requests:

$$\text{Request X Impact Factor on Upgrade Project 1} = \text{DF}(\%)(X) * \text{MW}(X) = X1$$

$$\text{Request Y Impact Factor on Upgrade Project 1} = \text{DF}(\%)(Y) * \text{MW}(Y) = Y1$$

$$\text{Request Z Impact Factor on Upgrade Project 1} = \text{DF}(\%)(Z) * \text{MW}(Z) = Z1$$

- Determine each request's Allocation of Cost for that particular project:

$$\text{Request X's Project 1 Cost Allocation} (\$) = \frac{\text{Network Upgrade Project 1 Cost}(\$) * X1}{X1 + Y1 + Z1}$$

- Repeat previous for each responsible GI request for each Project

The cost allocation of each needed Network Upgrade is determined by the size of each request and its impact on the given project. This allows for the most efficient and reasonable mechanism for sharing the costs of upgrades.

Credits for Amounts Advanced for Network Upgrades - Interconnection Customer shall be entitled to credits in accordance with Attachment Z1 of the SPP Tariff for any Network Upgrades including any tax gross-up or any other tax-related payments associated with the Network Upgrades, and not refunded to the Interconnection Customer.

Interconnection Facilities

The requirement to interconnect the 2,262 MW of generation into the existing and proposed transmission systems in the affected areas of the SPP transmission footprint consist of the necessary cost allocated shared facilities listed in Appendix F by upgrade. The interconnection requirements for the cluster total \$261,000,000. Interconnection Facilities specific to each generation interconnection request are listed in Appendix E.

A list of constraints with greater than or equal to a 20% OTDF that were identified and used for mitigation is listed in Appendix G. Other Network Constraints in the MIDW, MKEC, MIPU, NPPD, OKGE, OPPD, SPS, SUNC, WERE and WFEC transmission systems that were identified are shown in Appendix H. With a defined source and sink in a TSR, this list of Network Constraints will be refined and expanded to account for all Network Upgrade requirements.

A preliminary one-line drawing for each generation interconnection request are listed in Appendix D. Figure 1 depicts the major transmission line Network Upgrades needed to support the interconnection of the generation amounts requested in this study.

Power flow

Power flow Analysis Methodology

The Southwest Power Pool (SPP) Criteria states that:

“The transmission system of the SPP region shall be planned and constructed so that the contingencies as set forth in the Criteria will meet the applicable *NERC Reliability Standards* for transmission planning. All MDWG power flow models shall be tested to verify compliance with the System Performance Standards from NERC Table 1 – Category A.”

The ACCC function of PSS/E was used to simulate single contingencies in portions or all of the modeled control areas of Midwest Energy Inc. (MIDW), Mid-Kansas Electric Power LLC (MKEC), Missouri Public Service (MIPU), Nebraska Public Power District (NPPD), Oklahoma Gas and Electric (OKGE), Omaha Public Power District (OPPD), Southwestern Public Service (SPS), Sunflower Electric Power Corporation (SUNC), Westar Energy (WERE), Western Farmers Electric Cooperative (WFEC) and other control areas were applied and the resulting scenarios analyzed. This satisfies the “more probable” contingency testing criteria mandated by NERC and the SPP criteria.

Power flow Analysis

A power flow analysis was conducted for each Interconnection Customer’s facility using modified versions of the 2011 (spring) peak, 2012 (summer and winter), and the 2016 (summer and winter) peak models. The output of the Interconnection Customer’s facility was offset in each model by a reduction in output of existing online SPP generation. This method allows the request to be studied as an Energy Resource (ER) Interconnection Request. The available seasonal models used were through the 2016 Winter Peak. Certain requests that requested Network Resource Interconnection

Service (NRIS) had an additional analysis conducted for sinking the energy in the interconnecting Transmission Owner's balancing authority.

This analysis was conducted assuming that previous queued requests in the immediate area of these interconnect requests were in-service. The analysis of the each Customer's project indicates that additional criteria violations will occur on the MIDW, MKEC, MIPU, NPPD, OKGE, OPPD, SPS, SUNC, WERE and WFEC transmission systems under steady state and contingency conditions in the peak seasons.

Cluster Group 1 (Woodward Area)

The Woodward group had 320 MW of interconnection requests in addition to the 3,344.2 MW of previously queued generation in the area. FPL Switch – Woodward 138kV rebuild is necessary for overloads experienced by Mooreland – Woodward 345kV and Mooreland 345/138kV transformer constraints. Stability Analysis indicated that the Beaver County – Gray County 345kV line may be necessary for interconnection.

Cluster Group 2 (Hitchland Area)

The Hitchland group had 300 MW of interconnection requests in addition to the 2,714.7 MW of previously queued generation in the area. With the withdrawal of higher queued projects, no constraints were found to need mitigating. The Group 2 Interconnection Requests are dependent upon the higher queued upgrade, Hitchland-Border 345kV. If higher queued requests withdraw, a subsequent restudy will be required to determine the Group 2 cost responsibility for this upgrade.

Cluster Group 3 (Spearville Area)

The Spearville group had 748.5 MW of interconnection requests in addition to the 2,697.4 MW of previously queued generation in the area. Voltage collapse was observed for outage of the Hitchland-Stevens County 345kV line. Stability Analysis indicated instability as well. A 345kV line from the Beaver County - Gray County tap point was necessary to alleviate the constraint. Local area constraints in the area of GEN-2010-049 were also observed including the St. John (MKEC) – St. John (MIDW) 115kV line, Huntsville- St John 115kV and an additional Medicine Lodge autotransformer.

Cluster Group 4 (Mingo/NW Kansas Group)

The Mingo/NW Kansas group had 0 MW of interconnection requests in addition to the 924.2 MW of previously queued generation in the area. No new constraints were found in this area.

Cluster Group 5 (Amarillo Area)

The Amarillo group had 0 MW of interconnection requests in addition to the 2,132.6 MW of previously queued generation in the area. No new constraints were found in this area.

Cluster Group 6 (South Panhandle/New Mexico)

The South Panhandle/New Mexico group had 142.6 MW of interconnection requests in addition to the 2,017 MW of previously queued generation in the area. The entire section from Lovington – Reed – McDonald – Tatum – ASGI-2010-020 will need to be rebuilt due to overloads caused by the ASGI-2010-020 affected system interconnection request.

Cluster Group 7 (Southwestern Oklahoma)

The Southwestern Oklahoma group had 65 MW of interconnection requests in addition to the 1,995 MW of previously queued generation in the area. The Clinton Junction – Elk City 138kV line will need to be rebuilt due to overloads caused by the GEN-2010-012 interconnection request.

Cluster Group 8 (South Central Kansas/North Oklahoma)

The South Central Kansas/North Oklahoma group had 0 MW of interconnection requests in addition to the 3,351.5 MW of previously queued generation in the area. No new constraints were found in this area.

Cluster Group 9 (Northeast Nebraska)

The Northeast Nebraska group had 200 MW of interconnection requests in addition to the 648.5 MW of previously queued generation in the area. Examination by the Transmission Owner has determined that line clearances will need to be raised to accommodate the interconnection of the Group 9 generator.

Cluster Group 10 (North Nebraska)

The North Nebraska group had 0 MW of interconnection requests in addition to the 356.2 MW of previously queued generation in the area. No new constraints were found in this area.

Cluster Group 11 (North Kansas)

The North Kansas group had 70 MW of interconnection requests in addition to the 1,297.9 MW of previously queued generation in the area. The interconnection request in Group 11 contributed to the voltage stability issue at Spearville and is assigned a portion of the Beaver-Gray 345kV line. Overloads on the Clifton – Green Leaf 115kV and Greenleaf – Knob Hill lines were observed. This overload will be mitigated by the addition of the Steele City – Knob Hill in the Expansion Plan.

Cluster Group 12 (Northwest Arkansas)

The Northwest Arkansas group had 0 MW of interconnection requests in addition to the 0 MW of previously queued generation in the area. No new constraints were found in this area.

Cluster Group 13 (Northwest Missouri)

The North Missouri group had 87.1 MW of interconnection requests in addition to the 2,036.5 MW of previously queued generation in the area. The GEN-2010-047 – Harbine 115kV line will need to be rebuilt due to overloads caused by the GEN-2010-047 interconnection request.

Cluster Group 14 (South Central Oklahoma)

The South Central Oklahoma group had 300 MW of interconnection requests in addition to the 950MW of previously queued generation in the area. An additional Northwest 345/138/13.8kV transformer will need to be installed for the overload caused by GEN-2010-040 NRIS service.

Cluster Group 15 (Southwest Nebraska)

The Southwest Nebraska group had 0 MW of interconnection requests in addition to the 89.7 MW of previously queued generation in the area. No new constraints were found in this area.

Stability Analysis

A stability analysis was conducted for each Interconnection Customer's facility using modified versions of the 2011 summer and 2011 winter peak models. The stability analysis was conducted with all upgrades in service that were identified in the power flow analysis. For each group, the interconnection requests were studied at 100% nameplate output while the other groups were dispatched at 20% output for wind requests and 100% output for fossil requests. The output of the Interconnection Customer's facility was offset in each model by a reduction in output of existing online SPP generation. The following synopsis is included for each group. The entire stability study for each group can be found in the Appendices.

Cluster Group 1 (Woodward Area)

The Group 1 stability analysis was not performed again for this restudy.

Cluster Group 2 (Hitchland Area)

The Group 2 stability analysis was not performed again for this restudy.

Cluster Group 3 (Spearville Area)

The Group 3 stability analysis was not performed again for this restudy.

Cluster Group 4 (Mingo Area)

There was no stability analysis conducted in the Mingo area due to no requests in the area.

Cluster Group 5 (Amarillo Area)

There was no stability analysis conducted in the Amarillo area due to no requests in the area.

Cluster Group 6 (South Panhandle Area)

The Group 6 stability analysis was not performed again for this restudy.

Cluster Group 7 (Southwest Oklahoma Area)

The Group 7 stability analysis was not performed again for this restudy.

Cluster Group 8 (South Central Kansas Area)

There was no stability analysis conducted in the South Central Kansas area due to no requests in the area.

Cluster Group 9 (Northeast Nebraska Area)

The Group 9 stability analysis was not performed again for this study.

Cluster Group 10 (North Nebraska Area)

There was no stability analysis conducted in the Southwest Nebraska area due to no requests in the area.

Cluster Group 11 (North Kansas Area)

The Group 11 stability analysis was not performed again for this study.

Cluster Group 12 (Northwest Arkansas Area)

There was no stability analysis conducted in the Northwest Arkansas area due to no requests in the area.

Cluster Group 13 (Northwest Missouri Area)

Cluster Group 14 (South Central Oklahoma)

The Group 14 stability analysis was not performed again for this study

Cluster Group 15 (Southwest Nebraska Area)

There was no stability analysis conducted in the Southwest Nebraska area due to no requests in the area.

Conclusion

The minimum cost of interconnecting all of the interconnection requests included in the Definitive Interconnection System Impact Study is estimated at \$261,000,000 for the Allocated Network Upgrades and Transmission Owner Interconnection Facilities are listed in Appendix E and F.

The required interconnection costs listed in Appendices E, and F, and other upgrades associated with Network Constraints do not include all costs associated with the deliverability of the energy to final customers. These costs are determined by separate studies if the Customer submits a Transmission Service Request (TSR) through SPP's Open Access Same Time Information System (OASIS) as required by Attachment Z1 of the SPP Open Access Transmission Tariff (OATT).

Appendix

A: Generation Interconnection Requests Considered for Impact Study

Request	Amount	Service	Area	Requested Point of Interconnection	Proposed Point of Interconnection	Requested In-Service Date
GEN-2010-001	300	ER	OKGE	HITCHLAND-WOODWARD 345KV	TAP HITCHLAND-WOODWARD 345KV	01/01/2012
GEN-2010-012	65	ER	WFEC	BRANTLEY 138kV	BRANTLEY 138kV	03/31/2012
GEN-2010-036	4.6	ER	WERE	6 th STREET 115kV	6 th STREET 115kV	08/01/2012
GEN-2010-040	300	NR	OKGE	CIMARRON 345kV	CIMARRON 345kV	11/30/2011
GEN-2010-041	10.5	ER	OPPD	S 1399 161kV	S 1399 161kV	12/31/2011
GEN-2010-043	320	ER	WFEC	MOORELAND 345kV	MOORELAND 345kV	05/01/2017
GEN-2010-045	197.8	ER/NR	SUNC	TAP HOLCOMB – SPEARVILLE 345kV	TAP HOLCOMB – SPEARVILLE 345kV	12/31/2012
GEN-2010-046	56	ER	SPS	TUCO 230kV	TUCO 230kV	05/01/2013
GEN-2010-047	72	ER/NR	NPPD	TAP BEATRICE – HARBINE 115Kv	TAP BEATRICE – HARBINE 115Kv	12/01/2012
GEN-2010-048	70	ER/NR	MIDW	TAP BEACH STATION – REDLINE 115kV	TAP BEACH STATION – REDLINE 115kV	12/31/2011
GEN-2010-049	49.6	ER	MKEC	PRATT 115kV	PRATT 115kV	09/01/2012
GEN-2010-051	200	ER	NPPD	TAP TWIN CHURCH – HOSKINS 230kV	TAP TWIN CHURCH – HOSKINS 230kV	12/15/2012
GEN-2010-052	301.3	ER	SPS	FINNEY 345kV	FINNEY 345kV	12/15/2013
GEN-2010-053	199.8	ER/NR	SUNC	COMANCHE 345kV	COMANCHE 345kV	12/31/2014
ASGI-2010-020	50	ER	SPS	TAP (LE) TATUM – (LE) CROSSROADS 69kV	TAP (LE) TATUM – (LE) CROSSROADS 69kV	
ASGI-2010-021	36.6	ER	SPS	TAP (LE) SAUNDERS TAP – (LE) ANDERSON 69kV	TAP (LE) SAUNDERS TAP – (LE) ANDERSON 69kV	
ASGI-2011-001	28.8	ER	SPS	Lovington 115kV	Lovington 115kV	
GROUPED TOTAL	2,262					

* Planned Facility

^ Proposed Facility

*** Electrically Remote Interconnection Requests

B: Prior Queued Interconnection Requests

Request	Amount	Area	Requested/Proposed Point of Interconnection	Status or In-Service Date
GEN-2001-014	96.0	WFEC	Fort Supply 138kV	On-Line
GEN-2001-026	74.0	WFEC	Washita 138kV	On-Line
GEN-2001-033	180.0	SPS	San Juan Mesa Tap 230kV	On-Line
GEN-2001-036	80.0	SPS	Caprock Tap 115kV	On-Line
GEN-2001-037	100.0	OKGE	Windfarm Switching 138kV	On-Line
GEN-2001-039A	105.0	MKEC	Tap Greensburg - Judson-Large 115kV	On Schedule for 2011
GEN-2001-039M	100.0	SUNC	Central Plains Tap 115kV	On-Line
GEN-2002-004	200.0	WERE	Latham 345kV	On-Line at 150MW
GEN-2002-005	120.0	WFEC	Red Hills Tap 138kV	On-Line
GEN-2002-008	240.0	SPS	*Hitchland 345kV	On-Line at 120MW
GEN-2002-009	80.0	SPS	Hansford County 115kV	On-Line
GEN-2002-022	240.0	SPS	Bushland 230kV	On-Line at 160MW
GEN-2002-025A	150.0	MKEC	Spearville 230kV	On-Line at 100.5MW
GEN-2003-004	100.0	WFEC	Washita 138kV	On-Line
GEN-2003-005	100.0	WFEC	Anadarko - Paradise 138kV	On Line
GEN-2003-006A	200.0	MKEC	Elm Creek 230kV	On-Line
GEN-2003-019	250.0	MIDW	Smoky Hills Tap 230kV	On-Line
GEN-2003-020	160.0	SPS	Martin 115kV	On-Line at 80MW
GEN-2003-022	120.0	AEPW	Washita 138kV	On-Line
GEN-2004-023	20.6	WFEC	Washita 138kV	On-Line
GEN-2004-014	154.5	MKEC	Spearville 230kV	On Schedule for 2011
GEN-2004-020	27.0	AEPW	Washita 138kV	On-Line
GEN-2005-003	30.6	WFEC	Washita 138kV	On-Line
GEN-2005-005	18.0	OKGE	Windfarm Tap 138kV	IA Pending
GEN-2005-008	120.0	OKGE	Woodward 138kV	On-Line
GEN-2005-012	250.0	SUNC	Spearville 345kV	On Schedule for 2012
GEN-2005-013	201.0	WERE	Tap Latham - Neosho	On Schedule for 2012
GEN-2005-017	340.0	SPS	Tap *Hitchland - Potter County 345kV	On Suspension
GEN-2006-002	101.0	AEPW	Grapevine - Elk City 230kV	On-Line
GEN-2006-006	205.5	MKEC	Spearville 345kV	IA Pending
GEN-2006-014	300.0	MIPU	Tap Maryville – Clarinda and tie Midway (WFARMS) 161kV	On Suspension
GEN-2006-017	300.0	MIPU	Tap Maryville – Clarinda and tie Midway (WFARMS) 161kV	On Suspension
GEN-2006-018	170.0	SPS	Tuco 230kV	On Schedule for 2011
GEN-2006-020S	18.9	SPS	DWS Frisco Tap	On Schedule for 12/31/2011
GEN-2006-020N	42.0	NPPD	Bloomfield 115kV	On-Line
GEN-2006-021	101.0	MKEC	Flat Ridge Tap 138kV	On-Line
GEN-2006-022	150.0	MKEC	Ninnescah Tap 115kV	On Suspension
GEN-2006-024S	19.8	WFEC	South Buffalo Tap 69kV	On-Line
GEN-2006-026	502.0	SPS	Hobbs 230kV	On-Line
GEN-2006-031	75.0	MIDW	Knoll 115kV	On-Line
GEN-2006-032	200.0	MIDW	South Hays 230kV	On Suspension
GEN-2006-034	81.0	SUNC	Kanarado 115kV	On Suspension
GEN-2006-035	225.0	AEPW	Sweetwater 230kV	On Schedule for 2011
GEN-2006-037N1	75.0	NPPD	Broken Bow 115kV	On Suspension
GEN-2006-038N019	80.0	NPPD	Petersburg 115kV	On-Line
GEN-2006-038	750.0	WFEC	Hugo 345kV	On Suspension
GEN-2006-038N005	80.0	NPPD	Broken Bow 115kV	On-Line
GEN-2006-039	400.0	SPS	Tap and Tie both Potter County - Plant X 230kV and Bushland - Deaf Smith 230kV	On Suspension
GEN-2006-040	108.0	SUNC	Mingo 115kV	On Schedule for 2010
GEN-2006-043	99.0	AEPW	Grapevine - Elk City 230kV	On Line
GEN-2006-044	370.0	SPS	*Hitchland 345kV	On Schedule for 2014
GEN-2006-044N	40.5	NPPD	Petersburg 115kV	On Schedule for 12/2011
GEN-2006-044N02	100.5	NPPD	GEN-2008-086N02 230kV	IA Pending
GEN-2006-045	240.0	SPS	Tap and Tie both Potter County - Plant X 230kV and Bushland - Deaf Smith 230kV	On Suspension
GEN-2006-046	131.0	OKGE	Dewey 138kV	On-Line
GEN-2006-047	240.0	SPS	Tap and Tie both Potter County - Plant X 230kV and Bushland - Deaf Smith 230kV	On Schedule for 2013
GEN-2006-049	400.0	SPS	*Hitchland - Finney 345kV	On Schedule for 2014
GEN-2007-002	160.0	SPS	Grapevine 115kV	On Suspension
GEN-2007-006	160.0	OKGE	Roman Nose 138kV	On Suspension
GEN-2007-011	135.0	SUNC	Syracuse 115kV	On Schedule

Request	Amount	Area	Requested/Proposed Point of Interconnection	Status or In-Service Date
GEN-2007-011N08	81.0	NPPD	Bloomfield 115kV	On-Line
GEN-2007-013	99.0	SUNC	Selkirk 115kV	On Suspension
GEN-2007-015	135.0	WERE	Tap Kelly – S1399 (OPPD) 161kV	On Suspension
GEN-2007-017	100.5	MIPU	Tap Maryville – Clarinda and tie Midway (WFARMS) 161kV	On Suspension
GEN-2007-021	201.0	OKGE	*Tatonga 345kV	On Schedule for 2014
GEN-2007-025	300.0	WERE	Tap Woodring – Wichita 345kV	On Schedule for 2012
GEN-2007-032	150.0	WFEC	Tap Clinton Junction – Clinton 138kV	On Schedule for 2012
GEN-2007-038	200.0	SUNC	Spearville 345kV	On Schedule for 2015
GEN-2007-040	200.1	SUNC	Tap Holcomb – Spearville 345kV	On Schedule for 2012
GEN-2007-043	200.0	OKGE	Minco 345kV	On-Line (100MW)
GEN-2007-044	300.0	OKGE	*Tatonga 345kV	On Schedule for 2014
GEN-2007-046	199.5	SPS	Hitchland 115kV	On Schedule for 2014
GEN-2007-048	400.0	SPS	Tap Amarillo South – Swisher 230kV	On Schedule for 2014
GEN-2007-050	170.0	OKGE	*Woodward 138kV	On-Line
GEN-2007-051	200.0	WFEC	Mooreland 138kV	On Schedule for 2014
GEN-2007-052	150.0	WFEC	Anadarko 138kV	On-Line
GEN-2007-053	110.0	MIPU	Tap Maryville – Clarinda and tie Midway (WFARMS) 161kV	On Schedule for 2013
GEN-2007-057	34.5	SPS	Moore County East 115kV	On Schedule for 2014
GEN-2007-062**	765.0	OKGE	*Woodward 345kV	On Schedule for 2014
GEN-2008-003	101.0	OKGE	*Woodward EHV 138kV	On-Line
GEN-2008-008	60.0	SPS	Graham 115kV	On Schedule for 2014
GEN-2008-009	60.0	SPS	San Juan Mesa Tap 230kV	On Schedule for 2014
GEN-2008-013	300.0	OKGE	Tap Woodring – Wichita 345kV	On Schedule for 2013
GEN-2008-014	150.0	SPS	Tap Tuco – Oklaunion 345kV	On Schedule for 2014
GEN-2008-016	248.0	SPS	Grassland 230kV	IA Pending
GEN-2008-017	300.0	SUNC	Setab 345kV	On Schedule for 2012
GEN-2008-018	405.0	SPS	Finney 345kV	On Schedule for 2012
GEN-2008-019**	300.0	OKGE	*Tatonga 345kV	On Schedule for 2015
GEN-2008-021	42.0	WERE	Wolf Creek 345kV	IA Pending
GEN-2008-022	300.0	SPS	Tap Eddy – Tolk 345kV	IA Pending
GEN-2008-023	150.0	AEPW	Hobart Junction 138kV	On Schedule for 2012
GEN-2008-025	101.2	SUNC	Ruleton 115kV	On Schedule for 2015
GEN-2008-029	250.5	OKGE	Woodward EHV 138kV	On Schedule for 2014
GEN-2008-037	100.8	WFEC	Tap Washita – Blue Canyon 138kV	On Schedule for 2011
GEN-2008-044	197.8	OKGE	Tatonga 345kV	On Schedule for 2011
GEN-2008-046	200.0	OKGE	Sunnyside 345kV	On Schedule for 2012
GEN-2008-047	300.0	SPS	Tap Hitchland – Woodward 345kV	IA Pending
GEN-2008-051	322.0	SPS	Potter 345kV	On Schedule for 2014
GEN-2008-071	76.8	OKGE	Newkirk 138kV	IA Pending
GEN-2008-079	100.5	MKEC	Tap Judson Large – Cudahy 115kV	On Schedule for 2012
GEN-2008-086N02	200.0	NPPD	Tap Ft. Randall – Columbus 230kV	On Schedule for 2014
GEN-2008-088	50.6	SPS	Vega 69kV	IA Pending
GEN-2008-092	201.0	MIDW	Postrock 230kV	IA Pending
GEN-2008-098	100.8	WERE	Tap Wolf Creek – Lacygne 345kV	IA Pending
GEN-2008-119O	60.0	OPPD	S1399 161kV	On-Line
GEN-2008-123N	89.7	NPPD	Tap Guide – Pauline 115kV	IA Pending
GEN-2008-124	200.1	SUNC	Spearville 345kV	On Schedule for 2014
GEN-2008-127	200.1	WERE	Tap Sooner – Rose Hill 345kV	On Schedule for 2012
GEN-2008-129	80.0	MIPU	Pleasant Hill 161kV	On-Line
GEN-2009-008	200.0	SUNC	South Hays 230kV	IA Pending
GEN-2009-011	50.0	MKEC	Tap Plainville – Phillipsburg 115kV	On Schedule for 2014
GEN-2009-016	141.0	AEPW	Falcon Road 138kV	On Schedule for 2012
GEN-2009-020	48.6	MIDW	Tap Bazine – Nekoma 69kV	IA Pending
GEN-2009-025	60.0	OKGE	Tap Deer Creek – Sinclair 69kV	On Suspension
GEN-2009-040	73.8	WERE	Tap Smittyville – Knob Hill 115kV	On Schedule for 2012
GEN-2009-060	84	WFEC	Gotebo 69kV	IA Pending
GEN-2009-067S	20	SPS	7 Rivers 69kV	IA Pending
GEN-2010-003	100.8	WERE	GEN-2008-098 345kV	IA Pending
GEN-2010-005	300	MKEC	GEN-2007-025 345kV	On Schedule for 2012
GEN-2010-006	205	SPS	Jones 230kV	On-Line
GEN-2010-007	73.8	SPS	TAP Pringle - Riverview 115kV	IA Pending
GEN-2010-008	64.4	WFEC	Fargo 69kV	IA Pending
GEN-2010-009	165.6	SUNC	Gray County 345kV	IA Pending
GEN-2010-010	100.5	NPPD	Tap Fort Randall - Kelly 230kV	IA Pending
GEN-2010-011	29.7	OKGE	GEN-2008-044 345kV	On Schedule for 2011
GEN-2010-014	358.8	SPS	Hitchland 345kV	IA Pending
GEN-2010-015	200.1	SUNC	Spearville 345kV	IA Pending
Broken Bow	8.3	NPPD	Genoa 115kV	On-Line
Ord	10.8	NPPD	Bloomfield 115kV	On-Line

Request	Amount	Area	Requested/Proposed Point of Interconnection	Status or In-Service Date
Stuart	2.1	NPPD	Petersburg 115kV	On-Line
Ainsworth	75.0	NPPD	Ainsworth Wind Tap 115kV	On-Line
Rosebud	30.0	NPPD	St. Francis 115kV	On-Line
Wolf Creek	1,170.0	WERE	Wolf Creek 345kV	On-Line
Genoa	4.0	NPPD	Genoa 115kV	On-Line
ASGI-2010-001	400.0	AECI	Tap Cooper – Fairport 345kV	AECI queue Affected Study
ASGI-2010-004	50.0	AECI	Tap Queen City – Lancaster 69kV	AECI queue Affected Study
ASGI-2010-005	99.0	AECI	Lathrop 161kV	AECI queue Affected Study
ASGI-2010-006	150.0	AECI	Tap Fairfax – Fairfax Tap 138kV	AECI queue Affected Study
ASGI-2010-007	150.0	AECI	Tap Fairfax – Fairfax Tap 138kV	AECI queue Affected Study
ASGI-2010-009	201.0	AECI	Osborn 161kV	AECI queue Affected Study
ASGI-2010-010	42	SPS	Lovington 115kV	Affected Study
ASGI-2010-011	48	SPS	Texas County 69kV	Affected Study
Llano Estacado	80.0	SPS	Llano Wind Farm Tap 115kV	On-Line
SPS DISTRIBUTED	90.0	SPS	Dumas_19ST 115kV	On-Line
			Etter 115kV	On-Line
			Sherman 115kV	On-Line
			Spearman 115kV	On-Line
			Texas County 115kV	On-Line
Montezuma	110.0	MKEC	Haggard 115kV	On-Line
TOTAL	24,156.7			

* Planned Facility

^ Proposed Facility

C: Study Groupings

Cluster	Request	Amount	Area	Proposed Point of Interconnection
Prior Queued	GEN-2001-014	96	WFEC	Fort Supply 138kV
	GEN-2001-037	100	OKGE	Windfarm Switching 138kV
	GEN-2002-005	120	WFEC	Red Hills Tap 138kV
	GEN-2005-005	18	OKGE	Windfarm Tap 138kV
	GEN-2005-008	120	OKGE	Woodward 138kV
	GEN-2006-024S	19.8	WFEC	South Buffalo Tap 69kV
	GEN-2006-046	131	OKGE	Dewey 138kV
	GEN-2007-006	160	OKGE	Roman Nose 138kV
	GEN-2007-021	201	OKGE	*Tatonga 345kV
	GEN-2007-044	300	OKGE	*Tatonga 345kV
	GEN-2007-050	170	OKGE	*Woodward 138kV
	GEN-2007-051	200	WFEC	Mooreland 138kV
	GEN-2007-062	765	OKGE	*Woodward 345kV
	GEN-2008-003	101	OKGE	*Woodward EHV 138kV
	GEN-2008-019	300	OKGE	*Tatonga 345kV
	GEN-2008-029	250.5	OKGE	WOODWARD EHV 138kV
	GEN-2008-044	197.8	OKGE	Tatonga 345kV
	GEN-2010-008	64.4	WFEC	Fargo 69kV
GEN-2010-011	29.7	OKGE	GEN-2008-044 345kV	
PRIOR QUEUED SUBTOTAL		3,344.2		
Cluster	Request	Amount	Area	Proposed Point of Interconnection
Woodward	GEN-2010-043	320	WFEC	Mooreland 345kV
Group 1 WOODWARD SUBTOTAL		320		
AREA TOTAL		3,664.2		

Cluster	Request	Amount	Area	Proposed Point of Interconnection
Prior Queued	SPS Distribution	90	SPS	Various
	ASGI-2010-011	48	SPS	Texas County 69kV
	GEN-2002-008	240	SPS	*Hitchland 345kV
	GEN-2002-009	80	SPS	Hansford County 115kV
	GEN-2003-020	160	SPS	Martin 115kV
	GEN-2005-017	340	SPS	*Tap Hitchland - Potter County 345kV
	GEN-2006-020S	18.9	SPS	DWS Frisco Tap
	GEN-2006-044	370	SPS	*Hitchland 345kV
	GEN-2006-049	400	SPS	*Tap Hitchland - Finney 345kV
	GEN-2007-046	199.5	SPS	Tap & Tie Texas County – Hitchland & DWS Frisco Tap – Hitchland 115kV
	GEN-2007-057	34.5	SPS	Moore County East 115kV
	GEN-2008-047	300	SPS	TAP HITCHLAND - WOODWARD 345kV
	GEN-2010-007	73.8	SPS	Tap Pringle – Riverview 115kV
	GEN-2010-014	360	SPS	Hitchland 345kV
PRIOR QUEUED SUBTOTAL		2,714.7		
Cluster	Request	Amount	Area	Proposed Point of Interconnection
Hitchland	GEN-2010-001	300	SPS	GEN-2008-047 345kV
Group 2 HITCHLAND SUBTOTAL		300		
AREA TOTAL		3,014.7		

Cluster	Request	Amount	Area	Proposed Point of Interconnection
Prior Queued	Montezuma	110	MKEC	Haggard 115kV
	GEN-2001-039A	105	MKEC	Tap Greensburg - Judson-Large 115kV
	GEN-2002-025A	150	MKEC	Spearville 230kV
	GEN-2004-014	154.5	MKEC	Spearville 230kV
	GEN-2005-012	250	SUNC	Spearville 345kV
	GEN-2006-006	205.5	SUNC	Spearville 230kV
	GEN-2006-021	101	MKEC	Flat Ridge Tap 138kV
	GEN-2006-022	150	MKEC	Ninnescah Tap 115kV
	GEN-2007-038	200	SUNC	Spearville 345kV
	GEN-2007-040	200.1	SUNC	Tap Holcomb – Spearville 345kV
	GEN-2008-018	405	SPS	Finney 345kV
	GEN-2008-079	100.5	MKEC	Tap Judson Large – Cudahy 115kV
	GEN-2008-124	200.1	SUNC	Spearville 230kV
	GEN-2010-009	165.6	SUNC	Gray County 345kV
GEN-2010-015	200.1	SUNC	Spearville 345kV	
PRIOR QUEUED SUBTOTAL		2,697.4		
Cluster	Request	Amount	Area	Proposed Point of Interconnection
Spearville	GEN-2010-045	197.8	SUNC	Tap Holcomb – Spearville 345kV
	GEN-2010-049	49.6	MKEC	Pratt 115kV
	GEN-2010-052	301.3	SPS	Finney 345kV
	GEN-2010-053	199.8	SUNC	Comanche 345kV
Group 3 SPEARVILLE SUBTOTAL		748.5		
AREA TOTAL		3,445.9		

Cluster	Request	Amount	Area	Proposed Point of Interconnection
Prior Queued	GEN-2001-039M	100	SUNC	Central Plains Tap 115kV
	GEN-2006-034	81	SUNC	Tap Kanarado - Sharon Springs 115kV
	GEN-2006-040	108	SUNC	Mingo 115kV
	GEN-2007-011	135	SUNC	Syracuse 115kV
	GEN-2007-013	99	SUNC	Selkirk 115kV
	GEN-2008-017	300	SUNC	Setab 345kV
	GEN-2008-025	101.2	SUNC	Ruleton 115kV
PRIOR QUEUED SUBTOTAL		924.2		
Cluster	Request	Amount	Area	Proposed Point of Interconnection
Group 4 MINGO/NW KANSAS SUBTOTAL		0.0		
AREA TOTAL		924.2		

Cluster	Request	Amount	Area	Proposed Point of Interconnection
Prior Queued	Llano Estacado	80	SPS	Llano Estacado Tap 115kV
	GEN-2002-022	240	SPS	Bushland 230kV
	GEN-2006-039	400	SPS	Tap and Tie both Potter County - Plant X 230kV and Bushland - Deaf Smith 230kV
	GEN-2006-045	240	SPS	Tap and Tie both Potter County - Plant X 230kV and Bushland - Deaf Smith 230kV
	GEN-2006-047	240	SPS	Tap and Tie both Potter County - Plant X 230kV and Bushland - Deaf Smith 230kV
	GEN-2007-002	160	SPS	Grapevine 115kV
	GEN-2007-048	400	SPS	Tap Amarillo South – Swisher 230kV
	GEN-2008-051	322	SPS	Potter 345kV
	GEN-2008-088	50.6	SPS	Vega 69kV
PRIOR QUEUED SUBTOTAL		2,132.6		
Cluster	Request	Amount	Area	Proposed Point of Interconnection
Group 5 AMARILLO SUBTOTAL		0.0		
AREA TOTAL		2,132.6		

Cluster	Request	Amount	Area	Proposed Point of Interconnection
Prior Queued	ASGI-2010-010	42	SPS	Lovington 115kV
	GEN-2001-033	180	SPS	San Juan Mesa Tap 230kV
	GEN-2001-036	80	SPS	Caprock Tap 115kV
	GEN-2006-018	170	SPS	Tuco 230kV
	GEN-2006-026	502	SPS	Hobbs 230kV
	GEN-2008-008	60	SPS	Graham 115kV
	GEN-2008-009	60	SPS	San Juan Mesa Tap 230kV
	GEN-2008-014	150	SPS	Tap Tuco – Oklaunion 345kV
	GEN-2008-016	248	SPS	Grassland 230kV
	GEN-2008-022	300	SPS	Tap Eddy – Tolk 345kV
	GEN-2009-067S	20	SPS	7 Rivers 69kV
GEN-2010-006	205	SPS	Jones 230kV	
PRIOR QUEUED SUBTOTAL		2,017		
Cluster	Request	Amount	Area	Proposed Point of Interconnection
S Panhandle	ASGI-2010-020	50	SPS	Tap (LE) Tatum – (LE) Crossroads 69kV
	ASGI-2010-021	36.6	SPS	Tap (LE) Saunders Tap – (LE) Anderson 69kV
	GEN-2010-046	56	SPS	Tuco 230kV
Group 6 SOUTH PANHANDLE/NM SUBTOTAL		142.6		
AREA TOTAL		2,159.6		

Cluster	Request	Amount	Area	Proposed Point of Interconnection
Prior Queued	GEN-2001-026	74	WFEC	Washita 138kV
	GEN-2002-005	120	WFEC	Tap Morewood – Elk City 138kV
	GEN-2003-004	101	WFEC	Washita 138kV
	GEN-2003-005	100	WFEC	Anadarko - Paradise 138kV
	GEN-2003-022	120	AEPW	Washita 138kV
	GEN-2004-020	27	AEPW	Washita 138kV
	GEN-2004-023	21	WFEC	Washita 138kV
	GEN-2005-003	31	WFEC	Washita 138kV
	GEN-2006-002	101	AEPW	Grapevine - Elk City 230kV
	GEN-2006-035	225	AEPW	Grapevine - Elk City 230kV
	GEN-2006-043	99	AEPW	Grapevine - Elk City 230kV
	GEN-2007-032	150	WFEC	Tap Clinton Junction – Clinton 138kV
	GEN-2007-043	200	OKGE	Tap Lawton Eastside – Cimarron 345kV
	GEN-2007-052	150	WFEC	Anadarko 138kV
	GEN-2008-023	150	AEPW	Hobart Junction 138kV
	GEN-2008-037	101	WFEC	Tap Washita – Blue Canyon 138kV
	GEN-2009-016	141	AEPW	Falcon Road 138kV
GEN-2009-060	84	WFEC	Gotebo 69kV	
PRIOR QUEUED SUBTOTAL		1,995		
Cluster	Request	Amount	Area	Proposed Point of Interconnection
SW Oklahoma	GEN-2010-012	65	WFEC	Brantley 138kV
Group 7 SW OKLAHOMA SUBTOTAL		65		
AREA TOTAL		2,060		

Cluster	Request	Amount	Area	Proposed Point of Interconnection
Prior Queued	Wolf Creek	1170	WERE	Wolf Creek 345kV
	ASGI-2010-006	150	AECI	Tap Fairfax – Fairfax Tap 138kV
	ASGI-2010-007	150	AECI	Tap Fairfax – Fairfax Tap 138kV
	GEN-2002-004	200	WERE	Latham 345kV
	GEN-2005-013	201	WERE	Tap Latham - Neosho
	GEN-2007-025	300	WERE	Tap Woodring – Wichita 345kV
	GEN-2008-013	300	OKGE	Tap Woodring – Wichita 345kV
	GEN-2008-021	42	WERE	Wolf Creek 25kV
	GEN-2008-071	76.8	OKGE	Newkirk 138kV
	GEN-2008-098	100.8	WERE	Tap Wolf Creek – LaCygne 345kV
	GEN-2008-127	200.1	WERE	Tap Sooner – Rose Hill 345kV
	GEN-2009-025	60	OKGE	Tap Deer Creek – Sinclair 69kV
	GEN-2010-003	100.8	WERE	GEN-2008-098 345kV
	GEN-2010-005	300	WERE	GEN-2007-025 345kV
PRIOR QUEUED SUBTOTAL		3,351.5		
Cluster	Request	Amount	Area	Proposed Point of Interconnection
Group 8 NORTH OKLAHOMA SUBTOTAL		0.0		
AREA TOTAL		3,351.5		

Cluster	Request	Amount	Area	Proposed Point of Interconnection
Prior Queued	Genoa	4	NPPD	Genoa 115kV
	GEN-2006-020N	42	NPPD	Bloomfield 115kV
	GEN-2006-038N019	80	NPPD	Petersburg 115kV
	GEN-2006-044N	40.5	NPPD	Tap Neligh – Petersburg 115kV
	GEN-2006-044N02	100.5	NPPD	GEN-2008-086N02 230kV
	GEN-2007-011N08	81	NPPD	Bloomfield 115kV
	GEN-2008-086N02	200	NPPD	Tap Ft. Randall – Columbus 230kV
	GEN-2010-010	100.5	NPPD	Emerick 69kV
PRIOR QUEUED SUBTOTAL		648.5		
Cluster	Request	Amount	Area	Proposed Point of Interconnection
NE Nebraska	GEN-2010-051	200	NPPD	Tap Twin Church – Hoskins 230kV
Group 9 NE NEBRASKA SUBTOTAL		200		
AREA TOTAL		848.5		

Cluster	Request	Amount	Area	Proposed Point of Interconnection
Prior Queued	Broken Bow	8.3	NPPD	Genoa 115kV
	Ord	10.8	NPPD	Bloomfield 115kV
	Stuart	2.1	NPPD	Petersburg 115kV
	Ainsworth	75	NPPD	Ainsworth Wind Tap 115kV
	Rosebud Wind Project	30	NPPD	St. Francis 115kV
	Broken Bow	80	NPPD	Broken Bow 115kV
	GEN-2004-023N	75	NPPD	Columbus Co 115kV
	GEN-2006-037N1	75	NPPD	Broken Bow 115kV
PRIOR QUEUED SUBTOTAL		356.2		
Cluster	Request	Amount	Area	Proposed Point of Interconnection
Group 10 NORTH NEBRASKA SUBTOTAL		0.0		
AREA TOTAL		356.2		

Cluster	Request	Amount	Area	Proposed Point of Interconnection
Prior Queued	GEN-2003-006A-E	100	MKEC	Elm Creek 230kV
	GEN-2003-006A-W	100	MKEC	Elm Creek 230kV
	GEN-2003-019	250	MIDW	Smoky Hills Tap 230kV
	GEN-2006-031	75	MIDW	Knoll 115kV
	GEN-2006-032	200	MIDW	South Hays 230kV
	GEN-2008-092	201	MIDW	Knoll 115kV
	GEN-2009-008	199.5	SUNC	South Hays 230kV
	GEN-2009-011	50	MKEC	Tap Plainville – Phillipsburg 115kV
	GEN-2009-020	48.6	MIDW	Tap Bazine – Nekoma 69kV
	GEN-2009-040	73.8	WERE	Tap Smittyville – Knob Hill 115kV
PRIOR QUEUED SUBTOTAL		1,297.9		
Cluster	Request	Amount	Area	Proposed Point of Interconnection
North Kansas	GEN-2010-048	70	MIDW	Tap Beach Station – Redline 115kV
Group 11 NORTH KANSAS SUBTOTAL		70		
AREA TOTAL		1,367.9		

Cluster	Request	Amount	Area	Proposed Point of Interconnection
Prior Queued	ASGI-2010-001	400	AECI	Tap Cooper – Fairport 345kV
	ASGI-2010-002	201	AECI	Lathrop 161kV
	ASGI-2010-004	50	AECI	Tap Queen City – Lancaster 69kV
	ASGI-2010-005	99	AECI	Lathrop 161kV
	ASGI-2010-009	201	AECI	Osborn 161kV
	GEN-2006-014	300	MIPU	Tap Maryville – Clarinda 161kV & Tie to Midway 161kV
	GEN-2006-017	300	MIPU	Tap Maryville – Clarinda 161kV & Tie to Midway 161kV
	GEN-2007-015	135	WERE	Tap Humboldt – Kelly 161kV
	GEN-2007-017	100.5	MIPU	Tap Maryville – Clarinda 161kV & Tie to Midway 161kV
	GEN-2007-053	110	MIPU	Tap Maryville – Clarinda 161kV & Tie to Midway 161kV
	GEN-2008-1190	60	OPPD	Tap Humboldt – Kelly 161kV
	GEN-2008-129	80	MIPU	Pleasant Hill 161kV
	PRIOR QUEUED SUBTOTAL		2,036.5	
Cluster	Request	Amount	Area	Proposed Point of Interconnection
NW Missouri	GEN-2010-036	4.6	WERE	6 th Street 115kV
	GEN-2010-041	10.5	OPPD	S 1399 161kV
	GEN-2010-047	72	NPPD	TAP BEATRICE – HARBINE 115kV
Group 13 NORTHWEST MISSOURI SUBTOTAL		87.1		
AREA TOTAL		2,123.6		

Cluster	Request	Amount	Area	Proposed Point of Interconnection
Prior Queued	GEN-2006-038	750	WFEC	Hugo 345kV
	GEN-2008-046	200	OKGE	Sunnyside 345kV
PRIOR QUEUED SUBTOTAL		950		
Cluster	Request	Amount	Area	Proposed Point of Interconnection
SOUTH CENTRAL OKLAHOMA	GEN-2010-040	300	OKGE	Cimarron 345kV
Group 14 SOUTH CENTRAL OKLAHOMA SUBTOTAL		300		
AREA TOTAL		1,250		

Cluster	Request	Amount	Area	Proposed Point of Interconnection
Prior Queued	GEN-2008-123N	89.7	NPPD	Tap Guide – Pauline 115kV
PRIOR QUEUED SUBTOTAL		89.7		
Cluster	Request	Amount	Area	Proposed Point of Interconnection
	Group 15 SOUTHWEST NEBRASKA	0.0		
AREA TOTAL		89.7		

***CLUSTERED TOTAL (w/o PRIOR QUEUED)	2,262
***CLUSTERED TOTAL (w/PRIOR QUEUED)	27,188.6

* Planned Facility

^ Proposed Facility

** Alternate requests - counted as one request for study purpose

*** Electrically Remote Interconnection Requests

D: Proposed Point of Interconnection One line Diagrams

GEN-2010-001

Refer to Facility Study for GEN-2010-001

GEN-2010-012

Refer to Facility Study for GEN-2010-012

GEN-2010-036

Refer to Facility Study for GEN-2010-036

GEN-2010-040

Refer to Facility Study for GEN-2010-040

GEN-2010-041

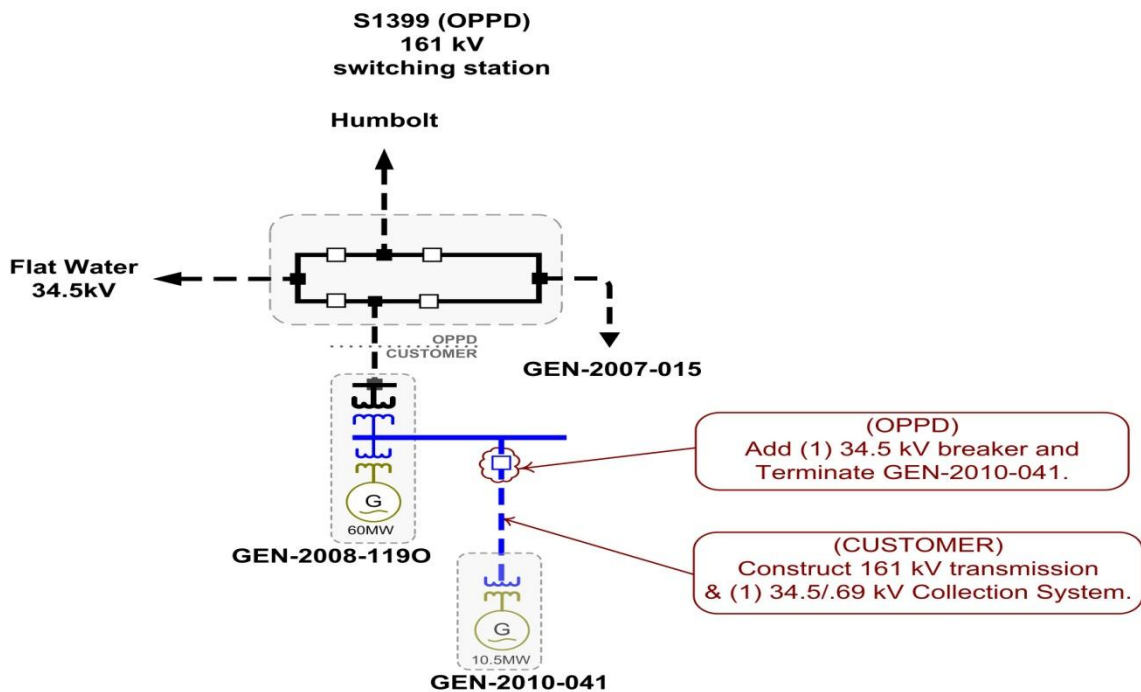

GEN-2010-043

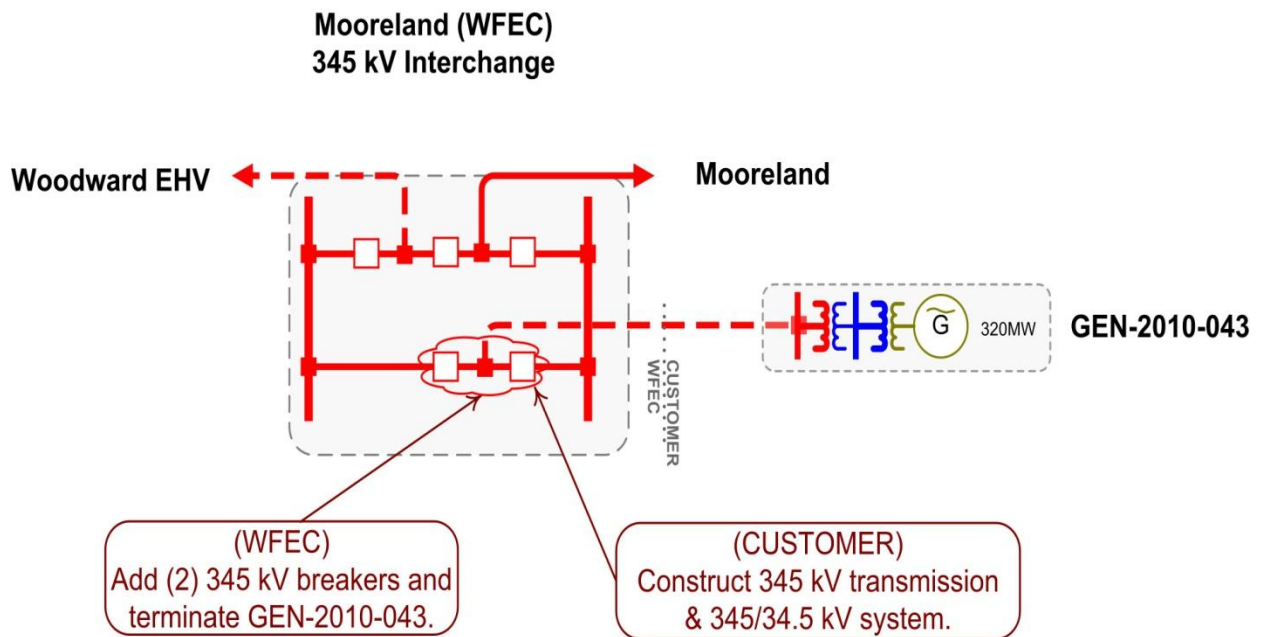

GEN-2010-045

Refer to Facility Study for GEN-2010-045

GEN-2010-046

Refer to Facility Study for GEN-2010-046

GEN-2010-048

Refer to Facility Study for GEN-2010-048

GEN-2010-049

Refer to Facility Study for GEN-2010-049

GEN-2010-051

Refer to Facility Study for GEN-2010-051

GEN-2010-052

Refer to Facility Study for GEN-2010-051

GEN-2010-053

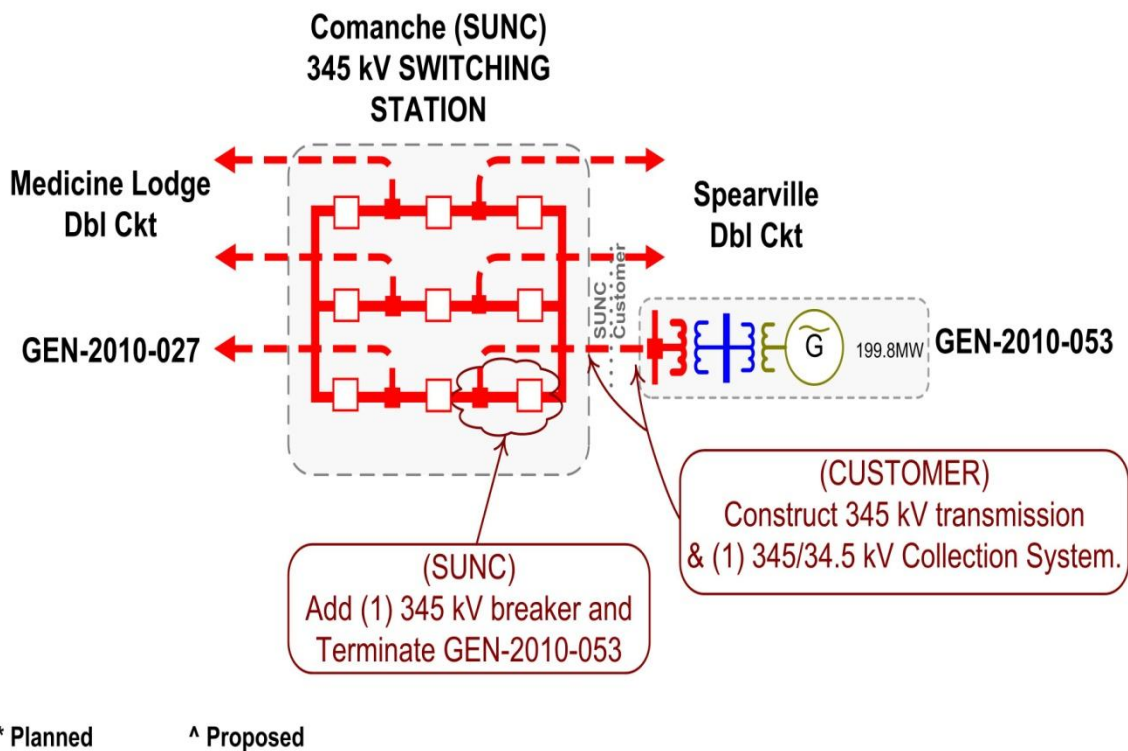

ASGI-2010-020

**New (SPS)
69 kV SWITCHING STATION**

LE - Crossroads

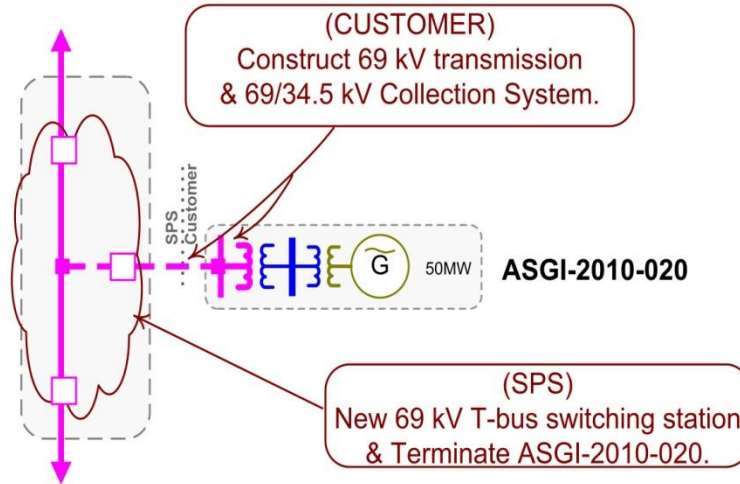

LE - Tatum

* Planned ^ Proposed

ASGI-2010-021

**New (SPS)
69 kV SWITCHING STATION**

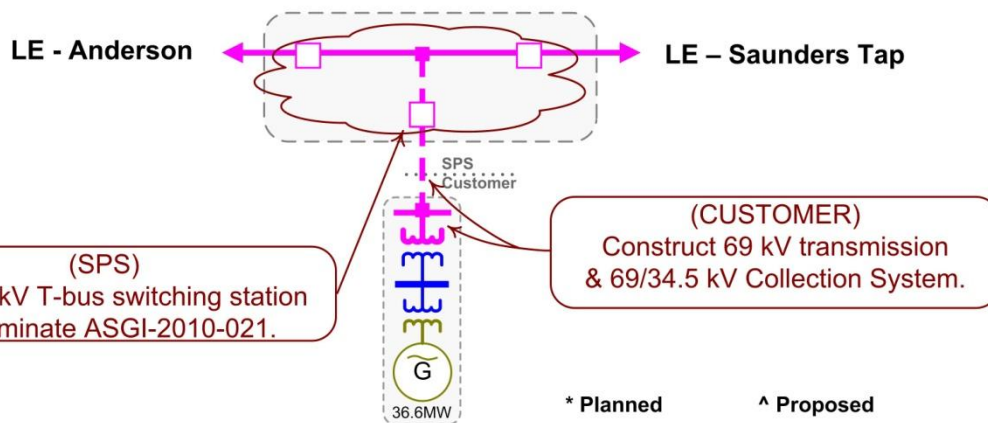

ASGI-2010-021

* Planned ^ Proposed

ASGI-2011-001

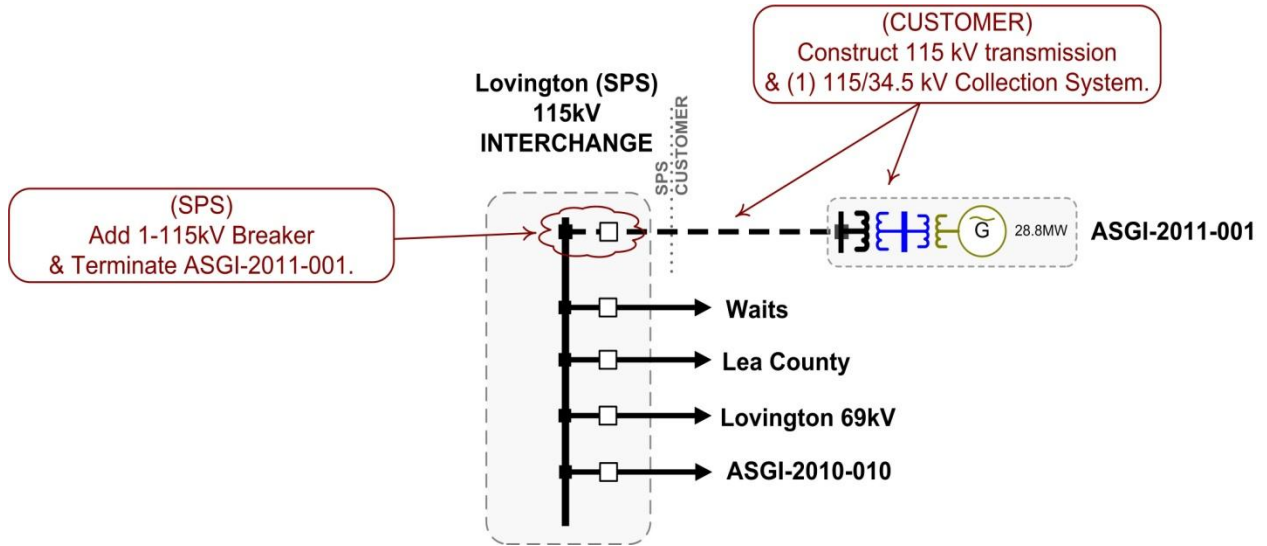

**E: Cost Allocation per Interconnection Request (Including Prior
Queued Upgrades)**

Appendix E. Cost Allocation Per Request

(Including Previously Allocated Network Upgrades*)

Interconnection Request and Upgrades	Upgrade Type	Allocated Cost	Upgrade Cost
ASGI-2010-020			
ASGI 2010 -020- Tatum 69kV LCEC Costs	Current Study	\$0.00	\$0.00
ASGI 2010-020 Interconnection Costs See Online Diagram.	Current Study	\$0.00	\$0.00
McDonald - Reed 69kV LCEC Costs	Current Study	\$0.00	\$0.00
Reed - Lovington 69kV LCEC Costs	Current Study	\$0.00	\$0.00
Tatum -McDonald 69kV LCEC Costs	Current Study	\$0.00	\$0.00
Beaver - Woodward 345kV Dbl CKT Priority Project: Hitchland - Woodward Dbl 345kV CKT (Total Project E&C Cost Shown)	Previously Allocated		\$247,005,793.00
Border - Tuco Interchange 345KV CKT 1 Balanced Portfolio: Tuco - Woodward 345kV (Total Project E&C Cost Shown)	Previously Allocated		\$148,727,500.00
Border - Woodward 345KV CKT 1 Balanced Portfolio: Tuco - Woodward 345kV (Total Project E&C Cost Shown)	Previously Allocated		\$148,727,500.00
Hitchland - Beaver 345kV Dbl CKT Priority Project: Hitchland - Woodward Dbl 345kV CKT (Total Project E&C Cost Shown)	Previously Allocated		\$247,005,793.00
Medicine Lodge - Wichita 345KV Dbl CKT Priority Project: Spearville - Comanche - Med Lodge - Wichita Dbl 345kV CKT (Total Project E&C Cost Shown.)	Previously Allocated		\$356,300,000.00
Medicine Lodge - Woodward 345KV Dbl CKT Priority Project: Med Lodge - Woodward Dbl 345kV CKT (Total Project E&C Cost Shown)	Previously Allocated		\$194,972,759.00
Medicine Lodge 345/138KV Transformer CKT 1 Priority Project: Spearville - Comanche - Med Lodge - Wichita Dbl 345kV CKT (Total Project E&C Cost Shown.)	Previously Allocated		\$356,300,000.00
	Current Study Total	\$0.00	
ASGI-2010-021			
ASGI 2010-021 Interconnection Costs See Online Diagram.	Current Study	\$0.00	\$0.00

* Withdrawal of higher queued projects will cause a restudy and may result in higher costs

Interconnection Request and Upgrades	Upgrade Type	Allocated Cost	Upgrade Cost
Beaver - Woodward 345kV Dbl CKT Priority Project: Hitchland - Woodward Dbl 345kV CKT (Total Project E&C Cost Shown)	Previously Allocated		\$247,005,793.00
Border - Tuco Interchange 345KV CKT 1 Balanced Portfolio: Tuco - Woodward 345kV (Total Project E&C Cost Shown)	Previously Allocated		\$148,727,500.00
Border - Woodward 345KV CKT 1 Balanced Portfolio: Tuco - Woodward 345kV (Total Project E&C Cost Shown)	Previously Allocated		\$148,727,500.00
Hitchland - Beaver 345kV Dbl CKT Priority Project: Hitchland - Woodward Dbl 345kV CKT (Total Project E&C Cost Shown)	Previously Allocated		\$247,005,793.00
Medicine Lodge - Wichita 345KV Dbl CKT Priority Project: Spearville - Comanche - Med Lodge - Wichita Dbl 345kV CKT (Total Project E&C Cost Shown.)	Previously Allocated		\$356,300,000.00
Medicine Lodge - Woodward 345KV Dbl CKT Priority Project: Med Lodge - Woodward Dbl 345kV CKT (Total Project E&C Cost Shown)	Previously Allocated		\$194,972,759.00
Medicine Lodge 345/138KV Transformer CKT 1 Priority Project: Spearville - Comanche - Med Lodge - Wichita Dbl 345kV CKT (Total Project E&C Cost Shown.)	Previously Allocated		\$356,300,000.00
	Current Study Total	\$0.00	

ASGI-2011-001

ASGI 2011-001 Interconnection Costs See Online Diagram.	Current Study	\$0.00	\$0.00
Beaver - Woodward 345kV Dbl CKT Priority Project: Hitchland - Woodward Dbl 345kV CKT (Total Project E&C Cost Shown)	Previously Allocated		\$247,005,793.00
Border - Tuco Interchange 345KV CKT 1 Balanced Portfolio: Tuco - Woodward 345kV (Total Project E&C Cost Shown)	Previously Allocated		\$148,727,500.00
Border - Woodward 345KV CKT 1 Balanced Portfolio: Tuco - Woodward 345kV (Total Project E&C Cost Shown)	Previously Allocated		\$148,727,500.00
Hitchland - Beaver 345kV Dbl CKT Priority Project: Hitchland - Woodward Dbl 345kV CKT (Total Project E&C Cost Shown)	Previously Allocated		\$247,005,793.00
Medicine Lodge - Wichita 345KV Dbl CKT Priority Project: Spearville - Comanche - Med Lodge - Wichita Dbl 345kV CKT (Total Project E&C Cost Shown.)	Previously Allocated		\$356,300,000.00
Medicine Lodge - Woodward 345KV Dbl CKT Priority Project: Med Lodge - Woodward Dbl 345kV CKT (Total Project E&C Cost Shown)	Previously Allocated		\$194,972,759.00
Medicine Lodge 345/138KV Transformer CKT 1 Priority Project: Spearville - Comanche - Med Lodge - Wichita Dbl 345kV CKT (Total Project E&C Cost Shown.)	Previously Allocated		\$356,300,000.00

* Withdrawal of higher queued projects will cause a restudy and may result in higher costs

Interconnection Request and Upgrades	Upgrade Type	Allocated Cost	Upgrade Cost
	Current Study Total	\$0.00	
GEN-2010-001			
GEN 2010-001 Interconnection Costs See Online Diagram.	Current Study	\$3,566,677.00	\$3,566,677.00
Beaver - Woodward 345kV Dbl CKT Priority Project: Hitchland - Woodward Dbl 345kV CKT (Total Project E&C Cost Shown)	Previously Allocated		\$247,005,793.00
Border - Tuco Interchange 345KV CKT 1 Balanced Portfolio: Tuco - Woodward 345kV (Total Project E&C Cost Shown)	Previously Allocated		\$148,727,500.00
Finney Switching Station - Holcomb 345KV CKT 2 Per GEN-2006-044 Facility Study	Previously Allocated		\$6,299,839.00
Hitchland - Border 345 kV CKT 1 Build approximately 105 miles of 345kV.	Previously Allocated		\$227,757,964.00
Medicine Lodge - Wichita 345KV Dbl CKT Priority Project: Spearville - Comanche - Med Lodge - Wichita Dbl 345kV CKT (Total Project E&C Cost Shown.)	Previously Allocated		\$356,300,000.00
Medicine Lodge - Woodward 345KV Dbl CKT Priority Project: Med Lodge - Woodward Dbl 345kV CKT (Total Project E&C Cost Shown)	Previously Allocated		\$194,972,759.00
Medicine Lodge 345/138KV Transformer CKT 1 Priority Project: Spearville - Comanche - Med Lodge - Wichita Dbl 345kV CKT (Total Project E&C Cost Shown.)	Previously Allocated		\$356,300,000.00
Tuco Interchange 345/230/13.2KV Autotransformer CKT 2 Balanced Portfolio: Tuco 345/230 kV Transformer CKT 2 (Total Project E&C Cost Shown)	Previously Allocated		\$11,250,000.00
	Current Study Total	\$3,566,677.00	
GEN-2010-012			
Clinton Junction - Elk City 138kV Rebuild 24 miles of 138kV from Clinton Junction - Elk City	Current Study	\$20,300,007.00	\$20,300,007.00
GEN 2010-012 Interconnection Costs See Online Diagram.	Current Study	\$3,500,000.00	\$3,500,000.00
Gracemont Transformer 345/138/13.8KV CKT 1 Priority Project: Gracemont Transformer 345/138/13.8KV CKT 1 (Total Project E&C Cost Shown)	Previously Allocated		\$8,000,000.00
Washita - Gracemont 138kV CKT 2 Build approximately 11 miles of 138kV.	Previously Allocated		\$5,621,986.00
	Current Study Total	\$23,800,007.00	
GEN-2010-036			

* Withdrawal of higher queued projects will cause a restudy and may result in higher costs

Interconnection Request and Upgrades	Upgrade Type	Allocated Cost	Upgrade Cost
GEN 2010-036 Interconnection Costs See Online Diagram.	Current Study	\$204,600.00	\$204,600.00
	Current Study Total	\$204,600.00	
GEN-2010-040			
GEN 2010-040 Interconnection Costs See Online Diagram.	Current Study	\$8,046,756.00	\$8,046,756.00
Northwest 345/138/13.8KV Autotransformer CKT 1 NRIS only required upgrade: Per 2009-AG2-AFS6	Previously Allocated		\$15,000,000.00
	Current Study Total	\$8,046,756.00	
GEN-2010-041			
GEN 2010-041 Interconnection Costs See Online Diagram.	Current Study	\$0.00	\$0.00
	Current Study Total	\$0.00	
GEN-2010-043			
Beaver County - Gray County 345kV Build approximately 90 miles of 345kV from Beaver County - Gray County	Current Study	\$27,600,555.35	\$170,209,050.00
FPL Switch - Woodward 138kV Per 2010-AGP1-AFS-6	Current Study	\$6,000,000.00	\$6,000,000.00
GEN 2010-043 Interconnection Costs See Online Diagram.	Current Study	\$14,357,894.00	\$14,357,894.00
Border - Tuco Interchange 345KV CKT 1 Balanced Portfolio: Tuco - Woodward 345kV (Total Project E&C Cost Shown)	Previously Allocated		\$148,727,500.00
Border - Woodward 345KV CKT 1 Balanced Portfolio: Tuco - Woodward 345kV (Total Project E&C Cost Shown)	Previously Allocated		\$148,727,500.00
Fargo Junction - Woodward 69 kV CKT 1 Rebuild approximately 2 miles of 69kV.	Previously Allocated		\$750,000.00
Gracemont Transformer 345/138/13.8KV CKT 1 Priority Project: Gracemont Transformer 345/138/13.8KV CKT 1 (Total Project E&C Cost Shown)	Previously Allocated		\$8,000,000.00
Medicine Lodge - Wichita 345KV Dbl CKT Priority Project: Spearville - Comanche - Med Lodge - Wichita Dbl 345kV CKT (Total Project E&C Cost Shown.)	Previously Allocated		\$356,300,000.00
Medicine Lodge - Woodward 345KV Dbl CKT Priority Project: Med Lodge - Woodward Dbl 345kV CKT (Total Project E&C Cost Shown)	Previously Allocated		\$194,972,759.00

* Withdrawal of higher queued projects will cause a restudy and may result in higher costs

Interconnection Request and Upgrades	Upgrade Type	Allocated Cost	Upgrade Cost
Medicine Lodge 345/138KV Transformer CKT 1 Priority Project: Spearville - Comanche - Med Lodge - Wichita Dbl 345kV CKT (Total Project E&C Cost Shown.)	Previously Allocated		\$356,300,000.00
Tuco Interchange 345/230/13.2KV Autotransformer CKT 2 Balanced Portfolio: Tuco 345/230 kV Transformer CKT 2 (Total Project E&C Cost Shown)	Previously Allocated		\$11,250,000.00
	Current Study Total	\$47,958,449.35	

GEN-2010-045

Beaver County - Gray County 345kV Build approximately 90 miles of 345kV from Beaver County - Gray County	Current Study	\$54,677,922.96	\$170,209,050.00
GEN 2010-045 Interconnection Costs See Online Diagram.	Current Study	\$5,000,000.00	\$5,000,000.00
Axtell - PostRock 345KV CKT 1 Balanced Portfolio: Spearville - PostRock - Axtell 345kV CKT (Total Project E&C Cost Shown)	Previously Allocated		\$112,700,000.00
Border - Tuco Interchange 345KV CKT 1 Balanced Portfolio: Tuco - Woodward 345kV (Total Project E&C Cost Shown)	Previously Allocated		\$148,727,500.00
Hitchland - Border 345 kV CKT 1 Build approximately 105 miles of 345kV.	Previously Allocated		\$227,757,964.00
Medicine Lodge - Wichita 345KV Dbl CKT Priority Project: Spearville - Comanche - Med Lodge - Wichita Dbl 345kV CKT (Total Project E&C Cost Shown.)	Previously Allocated		\$356,300,000.00
Medicine Lodge 345/138KV Transformer CKT 1 Priority Project: Spearville - Comanche - Med Lodge - Wichita Dbl 345kV CKT (Total Project E&C Cost Shown.)	Previously Allocated		\$356,300,000.00
Post Rock 345/230/13.8KV Autotransformer CKT 1 Balanced Portfolio: Spearville - PostRock - Axtell 345kV CKT (Total Project E&C Cost Shown)	Previously Allocated		\$112,700,000.00
Post Rock 345/230/13.8kV Autotransformer CKT 2 DISIS-2010-001 Restudy	Previously Allocated		\$13,749,527.00
PostRock - GEN-2010-016 Tap 345KV CKT 1 Balanced Portfolio: Spearville - PostRock - Axtell 345kV CKT (Total Project E&C Cost Shown)	Previously Allocated		\$112,700,000.00
Spearville - GEN-2010-016 Tap 345KV CKT 1 Balanced Portfolio: Spearville - PostRock - Axtell 345kV CKT (Total Project E&C Cost Shown)	Previously Allocated		\$112,700,000.00
Tuco Interchange 345/230/13.2KV Autotransformer CKT 2 Balanced Portfolio: Tuco 345/230 kV Transformer CKT 2 (Total Project E&C Cost Shown)	Previously Allocated		\$11,250,000.00
	Current Study Total	\$59,677,922.96	

GEN-2010-046

* Withdrawal of higher queued projects will cause a restudy and may result in higher costs

Interconnection Request and Upgrades	Upgrade Type	Allocated Cost	Upgrade Cost
GEN 2010-046 Interconnection Costs See Online Diagram.	Current Study	\$1,000,000.00	\$1,000,000.00
Beaver - Woodward 345kV Dbl CKT Priority Project: Hitchland - Woodward Dbl 345kV CKT (Total Project E&C Cost Shown)	Previously Allocated		\$247,005,793.00
Border - Tuco Interchange 345KV CKT 1 Balanced Portfolio: Tuco - Woodward 345kV (Total Project E&C Cost Shown)	Previously Allocated		\$148,727,500.00
Border - Woodward 345KV CKT 1 Balanced Portfolio: Tuco - Woodward 345kV (Total Project E&C Cost Shown)	Previously Allocated		\$148,727,500.00
Hitchland - Beaver 345kV Dbl CKT Priority Project: Hitchland - Woodward Dbl 345kV CKT (Total Project E&C Cost Shown)	Previously Allocated		\$247,005,793.00
Medicine Lodge - Wichita 345KV Dbl CKT Priority Project: Spearville - Comanche - Med Lodge - Wichita Dbl 345kV CKT (Total Project E&C Cost Shown.)	Previously Allocated		\$356,300,000.00
Medicine Lodge - Woodward 345KV Dbl CKT Priority Project: Med Lodge - Woodward Dbl 345kV CKT (Total Project E&C Cost Shown)	Previously Allocated		\$194,972,759.00
Medicine Lodge 345/138KV Transformer CKT 1 Priority Project: Spearville - Comanche - Med Lodge - Wichita Dbl 345kV CKT (Total Project E&C Cost Shown.)	Previously Allocated		\$356,300,000.00
	Current Study Total	\$1,000,000.00	

GEN-2010-048

Beaver County - Gray County 345kV Build approximately 90 miles of 345kV from Beaver County - Gray County	Current Study	\$8,190,639.49	\$170,209,050.00
GEN 2010-048 Interconnection Costs See Online Diagram.	Current Study	\$2,144,524.00	\$2,144,524.00
Axtell - PostRock 345KV CKT 1 Balanced Portfolio: Spearville - PostRock - Axtell 345kV CKT (Total Project E&C Cost Shown)	Previously Allocated		\$112,700,000.00
Beaver - Woodward 345kV Dbl CKT Priority Project: Hitchland - Woodward Dbl 345kV CKT (Total Project E&C Cost Shown)	Previously Allocated		\$247,005,793.00
Medicine Lodge - Wichita 345KV Dbl CKT Priority Project: Spearville - Comanche - Med Lodge - Wichita Dbl 345kV CKT (Total Project E&C Cost Shown.)	Previously Allocated		\$356,300,000.00
PostRock - GEN-2010-016 Tap 345KV CKT 1 Balanced Portfolio: Spearville - PostRock - Axtell 345kV CKT (Total Project E&C Cost Shown)	Previously Allocated		\$112,700,000.00
Spearville - GEN-2010-016 Tap 345KV CKT 1 Balanced Portfolio: Spearville - PostRock - Axtell 345kV CKT (Total Project E&C Cost Shown)	Previously Allocated		\$112,700,000.00

* Withdrawal of higher queued projects will cause a restudy and may result in higher costs

Interconnection Request and Upgrades	Upgrade Type	Allocated Cost	Upgrade Cost
	Current Study Total	\$10,335,163.49	
GEN-2010-049			
Beaver County - Gray County 345kV Build approximately 90 miles of 345kV from Beaver County - Gray County	Current Study	\$2,757,040.10	\$170,209,050.00
GEN 2010-049 Interconnection Costs See Online Diagram.	Current Study	\$2,750,000.00	\$2,750,000.00
Huntsville - Hutchinson Energy Center Rebuild approximately 29 miles of 115kV	Current Study	\$5,808,650.00	\$5,808,650.00
Huntsville - St. John 115kV Replace Line Trap	Current Study	\$200,000.00	\$200,000.00
St. John - St. John 115kV CKT 1 Rebuild 115kV tie between St. John - St. John	Current Study	\$500,000.00	\$500,000.00
Axtell - PostRock 345KV CKT 1 Balanced Portfolio: Spearville - PostRock - Axtell 345kV CKT (Total Project E&C Cost Shown)	Previously Allocated		\$112,700,000.00
Border - Tuco Interchange 345KV CKT 1 Balanced Portfolio: Tuco - Woodward 345kV (Total Project E&C Cost Shown)	Previously Allocated		\$148,727,500.00
Medicine Lodge - Wichita 345KV Dbl CKT Priority Project: Spearville - Comanche - Med Lodge - Wichita Dbl 345kV CKT (Total Project E&C Cost Shown.)	Previously Allocated		\$356,300,000.00
Medicine Lodge 345/115kV transformer Install new 345/115kV transformer at Medicine Lodge	Previously Allocated		\$10,000,000.00
PostRock - GEN-2010-016 Tap 345KV CKT 1 Balanced Portfolio: Spearville - PostRock - Axtell 345kV CKT (Total Project E&C Cost Shown)	Previously Allocated		\$112,700,000.00
Pratt - Sawyer 115KV CKT 1 Per 2007-AG3-AFS9	Previously Allocated		\$1,612,500.00
Pratt - St. John 115kV CKT 1 Rebuild approximately 22 miles of 115kV	Previously Allocated		
Spearville - GEN-2010-016 Tap 345KV CKT 1 Balanced Portfolio: Spearville - PostRock - Axtell 345kV CKT (Total Project E&C Cost Shown)	Previously Allocated		\$112,700,000.00
Spearville 345/115/13.8kV Transformer CKT 1 New 345/115kV Spearville Transformer (Partial Cost allocation)	Previously Allocated		\$3,745,000.00
Tuco Interchange 345/230/13.2KV Autotransformer CKT 2 Balanced Portfolio: Tuco 345/230 kV Transformer CKT 2 (Total Project E&C Cost Shown)	Previously Allocated		\$11,250,000.00

* Withdrawal of higher queued projects will cause a restudy and may result in higher costs

Interconnection Request and Upgrades	Upgrade Type	Allocated Cost	Upgrade Cost
	Current Study Total	\$12,015,690.10	
GEN-2010-051			
GEN 2010-051 Interconnection Costs See Online Diagram.	Current Study	\$6,700,000.00	\$6,700,000.00
Twin Church - Dixon County 230kV Increase clearances on Twin Church - Dixon County 230kV	Current Study	\$100,000.00	\$100,000.00
Albion - Petersbug 115kV CKT 1 Line re-rating to 100°C	Previously Allocated		\$900,000.00
	Current Study Total	\$6,800,000.00	
GEN-2010-052			
Beaver County - Gray County 345kV Build approximately 90 miles of 345kV from Beaver County - Gray County	Current Study	\$52,884,396.36	\$170,209,050.00
GEN 2010-052 Interconnection Costs See Online Diagram.	Current Study	\$6,766,756.00	\$6,766,756.00
Axtell - PostRock 345KV CKT 1 Balanced Portfolio: Spearville - PostRock - Axtell 345kV CKT (Total Project E&C Cost Shown)	Previously Allocated		\$112,700,000.00
Border - Tuco Interchange 345KV CKT 1 Balanced Portfolio: Tuco - Woodward 345kV (Total Project E&C Cost Shown)	Previously Allocated		\$148,727,500.00
Border - Woodward 345KV CKT 1 Balanced Portfolio: Tuco - Woodward 345kV (Total Project E&C Cost Shown)	Previously Allocated		\$148,727,500.00
Hitchland - Border 345 kV CKT 1 Build approximately 105 miles of 345kV.	Previously Allocated		\$227,757,964.00
Medicine Lodge - Wichita 345KV Dbl CKT Priority Project: Spearville - Comanche - Med Lodge - Wichita Dbl 345kV CKT (Total Project E&C Cost Shown.)	Previously Allocated		\$356,300,000.00
Medicine Lodge - Woodward 345KV Dbl CKT Priority Project: Med Lodge - Woodward Dbl 345kV CKT (Total Project E&C Cost Shown)	Previously Allocated		\$194,972,759.00
Medicine Lodge 345/138KV Transformer CKT 1 Priority Project: Spearville - Comanche - Med Lodge - Wichita Dbl 345kV CKT (Total Project E&C Cost Shown.)	Previously Allocated		\$356,300,000.00
Post Rock 345/230/13.8KV Autotransformer CKT 1 Balanced Portfolio: Spearville - PostRock - Axtell 345kV CKT (Total Project E&C Cost Shown)	Previously Allocated		\$112,700,000.00
Post Rock 345/230/13.8kV Autotransformer CKT 2 DISIS-2010-001 Restudy	Previously Allocated		\$13,749,527.00

* Withdrawal of higher queued projects will cause a restudy and may result in higher costs

Interconnection Request and Upgrades	Upgrade Type	Allocated Cost	Upgrade Cost
PostRock - GEN-2010-016 Tap 345KV CKT 1 Balanced Portfolio: Spearville - PostRock - Axtell 345kV CKT (Total Project E&C Cost Shown)	Previously Allocated		\$112,700,000.00
Spearville - GEN-2010-016 Tap 345KV CKT 1 Balanced Portfolio: Spearville - PostRock - Axtell 345kV CKT (Total Project E&C Cost Shown)	Previously Allocated		\$112,700,000.00
Tuco Interchange 345/230/13.2KV Autotransformer CKT 2 Balanced Portfolio: Tuco 345/230 kV Transformer CKT 2 (Total Project E&C Cost Shown)	Previously Allocated		\$11,250,000.00
	Current Study Total	\$59,651,152.36	

GEN-2010-053

Beaver County - Gray County 345KV Build approximately 90 miles of 345kV from Beaver County - Gray County	Current Study	\$24,098,495.74	\$170,209,050.00
GEN 2010-053 Interconnection Costs See Online Diagram.	Current Study	\$3,715,000.00	\$3,715,000.00
Axtell - PostRock 345KV CKT 1 Balanced Portfolio: Spearville - PostRock - Axtell 345kV CKT (Total Project E&C Cost Shown)	Previously Allocated		\$112,700,000.00
Border - Tuco Interchange 345KV CKT 1 Balanced Portfolio: Tuco - Woodward 345kV (Total Project E&C Cost Shown)	Previously Allocated		\$148,727,500.00
Hitchland - Border 345 kV CKT 1 Build approximately 105 miles of 345kV.	Previously Allocated		\$227,757,964.00
Medicine Lodge - Wichita 345KV Dbl CKT Priority Project: Spearville - Comanche - Med Lodge - Wichita Dbl 345kV CKT (Total Project E&C Cost Shown.)	Previously Allocated		\$356,300,000.00
Medicine Lodge 345/138KV Transformer CKT 1 Priority Project: Spearville - Comanche - Med Lodge - Wichita Dbl 345kV CKT (Total Project E&C Cost Shown.)	Previously Allocated		\$356,300,000.00
Post Rock 345/230/13.8KV Autotransformer CKT 1 Balanced Portfolio: Spearville - PostRock - Axtell 345kV CKT (Total Project E&C Cost Shown)	Previously Allocated		\$112,700,000.00
Post Rock 345/230/13.8kV Autotransformer CKT 2 DISIS-2010-001 Restudy	Previously Allocated		\$13,749,527.00
PostRock - GEN-2010-016 Tap 345KV CKT 1 Balanced Portfolio: Spearville - PostRock - Axtell 345kV CKT (Total Project E&C Cost Shown)	Previously Allocated		\$112,700,000.00
Spearville - GEN-2010-016 Tap 345KV CKT 1 Balanced Portfolio: Spearville - PostRock - Axtell 345kV CKT (Total Project E&C Cost Shown)	Previously Allocated		\$112,700,000.00
Tuco Interchange 345/230/13.2KV Autotransformer CKT 2 Balanced Portfolio: Tuco 345/230 kV Transformer CKT 2 (Total Project E&C Cost Shown)	Previously Allocated		\$11,250,000.00

* Withdrawal of higher queued projects will cause a restudy and may result in higher costs

Interconnection Request and Upgrades	Upgrade Type	Allocated Cost	Upgrade Cost
	Current Study Total	\$27,813,495.74	
TOTAL CURRENT STUDY COSTS:		\$260,869,914.00	

* Withdrawal of higher queued projects will cause a restudy and may result in higher costs

Tuesday, November 08, 2011

F: Cost Allocation per Proposed Study Network Upgrade

Appendix F. Cost Allocation by Upgrade

ASGI 2010-020 Interconnection Costs \$0.00

See Online Diagram.

ASGI-2010-020	\$0.00
Total Allocated Costs	\$0.00

ASGI 2010-021 Interconnection Costs \$0.00

See Online Diagram.

ASGI-2010-021	\$0.00
Total Allocated Costs	\$0.00

ASGI 2010 -020- Tatum 69kV \$0.00

LCEC Costs

ASGI-2010-020	\$0.00
Total Allocated Costs	\$0.00

ASGI 2011-001 Interconnection Costs \$0.00

See Online Diagram.

ASGI-2011-001	\$0.00
Total Allocated Costs	\$0.00

Beaver County - Gray County 345kV \$170,209,050.00

Build approximately 90 miles of 345kV from Beaver County - Gray County

GEN-2010-043	\$27,600,555.35
GEN-2010-045	\$54,677,922.96
GEN-2010-048	\$8,190,639.49
GEN-2010-049	\$2,757,040.10
GEN-2010-052	\$52,884,396.36
GEN-2010-053	\$24,098,495.74
Total Allocated Costs	\$170,209,050.00

Clinton Junction - Elk City 138kV \$20,300,007.00

Rebuild 24 miles of 138kV from Clinton Junction - Elk City

GEN-2010-012	\$20,300,007.00
Total Allocated Costs	\$20,300,007.00

FPL Switch - Woodward 138kV \$6,000,000.00

Per 2010-AGP1-AFS-6

GEN-2010-043	\$6,000,000.00
--------------	----------------

* Withdrawal of higher queued projects will cause a restudy and may result in higher costs

	Total Allocated Costs	\$6,000,000.00
Twin Church - Dixon County 230kV		\$100,000.00
Increase clearances on Twin Church - Dixon County 230kV		
	GEN-2010-051	\$100,000.00
	Total Allocated Costs	\$100,000.00
GEN 2010-001 Interconnection Costs		\$3,566,677.00
See Oonline Diagram.		
	GEN-2010-001	\$3,566,677.00
	Total Allocated Costs	\$3,566,677.00
GEN 2010-012 Interconnection Costs		\$3,500,000.00
See Oonline Diagram.		
	GEN-2010-012	\$3,500,000.00
	Total Allocated Costs	\$3,500,000.00
GEN 2010-036 Interconnection Costs		\$204,600.00
See Oonline Diagram.		
	GEN-2010-036	\$204,600.00
	Total Allocated Costs	\$204,600.00
GEN 2010-040 Interconnection Costs		\$8,046,756.00
See Oonline Diagram.		
	GEN-2010-040	\$8,046,756.00
	Total Allocated Costs	\$8,046,756.00
GEN 2010-041 Interconnection Costs		\$0.00
See Oonline Diagram.		
	GEN-2010-041	\$0.00
	Total Allocated Costs	\$0.00
GEN 2010-043 Interconnection Costs		\$14,357,894.00
See Oonline Diagram.		
	GEN-2010-043	\$14,357,894.00
	Total Allocated Costs	\$14,357,894.00
GEN 2010-045 Interconnection Costs		\$5,000,000.00
See Oonline Diagram.		
	GEN-2010-045	\$5,000,000.00

* Withdrawal of higher queued projects will cause a restudy and may result in higher costs

	Total Allocated Costs	\$5,000,000.00
GEN 2010-046 Interconnection Costs		\$1,000,000.00
See Oonline Diagram.		
	GEN-2010-046	\$1,000,000.00
	Total Allocated Costs	\$1,000,000.00
GEN 2010-048 Interconnection Costs		\$2,144,524.00
See Oonline Diagram.		
	GEN-2010-048	\$2,144,524.00
	Total Allocated Costs	\$2,144,524.00
GEN 2010-049 Interconnection Costs		\$2,750,000.00
See Oonline Diagram.		
	GEN-2010-049	\$2,750,000.00
	Total Allocated Costs	\$2,750,000.00
GEN 2010-051 Interconnection Costs		\$6,700,000.00
See Oonline Diagram.		
	GEN-2010-051	\$6,700,000.00
	Total Allocated Costs	\$6,700,000.00
GEN 2010-052 Interconnection Costs		\$6,766,756.00
See Oonline Diagram.		
	GEN-2010-052	\$6,766,756.00
	Total Allocated Costs	\$6,766,756.00
GEN 2010-053 Interconnection Costs		\$3,715,000.00
See Oonline Diagram.		
	GEN-2010-053	\$3,715,000.00
	Total Allocated Costs	\$3,715,000.00
Huntsville - Hutchinson Energy Center		\$5,808,650.00
Rebuild approximately 29 miles of 115kV		
	GEN-2010-049	\$5,808,650.00
	Total Allocated Costs	\$5,808,650.00
Huntsville - St. John 115kV		\$200,000.00
Replace Line Trap		
	GEN-2010-049	\$200,000.00

* Withdrawal of higher queued projects will cause a restudy and may result in higher costs

	Total Allocated Costs	\$200,000.00
McDonald - Reed 69kV		\$0.00
LCEC Costs		
	ASGI-2010-020	\$0.00
	Total Allocated Costs	\$0.00
Reed - Lovington 69kV		\$0.00
LCEC Costs		
	ASGI-2010-020	\$0.00
	Total Allocated Costs	\$0.00
St.John - St. John 115kV CKT 1		\$500,000.00
Rebuild 115kV tie between St. John - St. John		
	GEN-2010-049	\$500,000.00
	Total Allocated Costs	\$500,000.00
Tatum -McDonald 69kV		\$0.00
LCEC Costs		
	ASGI-2010-020	\$0.00
	Total Allocated Costs	\$0.00

* Withdrawal of higher queued projects will cause a restudy and may result in higher costs

G: Power flow Analysis (Constraints for Mitigation)

SOLUTION	GROUP	SCENARIO	SEASON	SOURCE	DIRECTION	MONITORED ELEMENT COMMON NAME	RATEB	TDF	TC%LOADING	CONTINGENCY NAME
FDNS	00ASGI_10_020		0 12WP	ASGI_2010_020	FROM->TO	ASGI-10-20T 69.000 - LEA COUNTY REC-TATUM 69KV CKT 1	41	1	154.0465	BASE CASE
FDNS	06ASGI_10_020		0 11G	ASGI_2010_020	FROM->TO	ASGI-10-20T 69.000 - LEA COUNTY REC-TATUM 69KV CKT 1	41	1	153.6068	BASE CASE
FDNS	00ASGI_10_020		0 16WP	ASGI_2010_020	FROM->TO	ASGI-10-20T 69.000 - LEA COUNTY REC-TATUM 69KV CKT 1	41	1	153.4254	BASE CASE
FDNS	00ASGI_10_020		0 12SP	ASGI_2010_020	FROM->TO	ASGI-10-20T 69.000 - LEA COUNTY REC-TATUM 69KV CKT 1	41	1	153.291	BASE CASE
FDNS	00ASGI_10_020		0 16SP	ASGI_2010_020	FROM->TO	ASGI-10-20T 69.000 - LEA COUNTY REC-TATUM 69KV CKT 1	41	1	152.5942	BASE CASE
FDNS	6		0 11G	ASGI_2010_020	FROM->TO	ASGI-10-20T 69.000 - LEA COUNTY REC-TATUM 69KV CKT 1	41	1	123.0075	BASE CASE
FDNS	00ASGI_10_020		0 12WP	ASGI_2010_020	TO->FROM	LEA COUNTY REC-LOVINGTON INTERCHANGE - LEA COUNTY REC-REED 69KV CKT 1	41	1	103.7852	LEA COUNTY REC-DENTON SUB - LEA COUNTY REC-REED 69KV CKT 1
FDNS	00ASGI_10_020		0 16WP	ASGI_2010_020	TO->FROM	LEA COUNTY REC-LOVINGTON INTERCHANGE - LEA COUNTY REC-REED 69KV CKT 1	41	1	101.5413	LEA COUNTY REC-DENTON SUB - LEA COUNTY REC-REED 69KV CKT 1
FDNS	00ASGI_10_020		0 12WP	ASGI_2010_020	FROM->TO	LEA COUNTY REC-MCDONALD - LEA COUNTY REC-REED 69KV CKT 1	41	1	133.0845	BASE CASE
FDNS	00ASGI_10_020		0 16WP	ASGI_2010_020	FROM->TO	LEA COUNTY REC-MCDONALD - LEA COUNTY REC-REED 69KV CKT 1	41	1	130.2048	BASE CASE
FDNS	06ASGI_10_020		0 11G	ASGI_2010_020	FROM->TO	LEA COUNTY REC-MCDONALD - LEA COUNTY REC-REED 69KV CKT 1	41	1	126.7077	BASE CASE
FDNS	00ASGI_10_020		0 12SP	ASGI_2010_020	FROM->TO	LEA COUNTY REC-MCDONALD - LEA COUNTY REC-REED 69KV CKT 1	41	1	124.6606	BASE CASE
FDNS	00ASGI_10_020		0 16SP	ASGI_2010_020	FROM->TO	LEA COUNTY REC-MCDONALD - LEA COUNTY REC-REED 69KV CKT 1	41	1	120.6645	BASE CASE
FDNS	00ASGI_10_020		0 12WP	ASGI_2010_020	TO->FROM	LEA COUNTY REC-MCDONALD - LEA COUNTY REC-TATUM 69KV CKT 1	41	1	137.6412	BASE CASE
FDNS	00ASGI_10_020		0 16WP	ASGI_2010_020	TO->FROM	LEA COUNTY REC-MCDONALD - LEA COUNTY REC-TATUM 69KV CKT 1	41	1	135.1855	BASE CASE
FDNS	06ASGI_10_020		0 11G	ASGI_2010_020	TO->FROM	LEA COUNTY REC-MCDONALD - LEA COUNTY REC-TATUM 69KV CKT 1	41	1	133.1062	BASE CASE
FDNS	00ASGI_10_020		0 12SP	ASGI_2010_020	TO->FROM	LEA COUNTY REC-MCDONALD - LEA COUNTY REC-TATUM 69KV CKT 1	41	1	131.575	BASE CASE
FDNS	00ASGI_10_020		0 16SP	ASGI_2010_020	TO->FROM	LEA COUNTY REC-MCDONALD - LEA COUNTY REC-TATUM 69KV CKT 1	41	1	128.2259	BASE CASE
FDNS	00ASGI_10_020		0 12WP	ASGI_2010_020	TO->FROM	LEA COUNTY REC-MCDONALD - LEA COUNTY REC-TATUM 69KV CKT 1	41	1	102.882	LEA COUNTY REC-LOVINGTON INTERCHANGE 115/69KV TRANSFORMER CKT 1
FDNS	6		0 11G	ASGI_2010_020	TO->FROM	LEA COUNTY REC-MCDONALD - LEA COUNTY REC-TATUM 69KV CKT 1	41	1	102.7893	BASE CASE
FDNS	00ASGI_10_020		0 16WP	ASGI_2010_020	TO->FROM	LEA COUNTY REC-MCDONALD - LEA COUNTY REC-TATUM 69KV CKT 1	41	1	100.728	LEA COUNTY REC-LOVINGTON INTERCHANGE 115/69KV TRANSFORMER CKT 1
FNSL-Blown up	02ALL		0 11G	ASGI_2010_020		Non Converged Contingency	0	0.17612	9999	DBL-G0847-WO
FNSL-Blown up	03ALL		0 11G	ASGI_2010_020		Non Converged Contingency	0	0.16598	9999	DBL-MEDLO-WI
FNSL-Blown up	02ALL		0 11G	ASGI_2010_021		Non Converged Contingency	0	0.17624	9999	DBL-G0847-WO
FNSL-Blown up	03ALL		0 11G	ASGI_2010_021		Non Converged Contingency	0	0.16601	9999	DBL-MEDLO-WI
FNSL-Blown up	02ALL		0 11G	ASGI_2011_001		Non Converged Contingency	0	0.17598	9999	DBL-G0847-WO
FNSL-Blown up	03ALL		0 11G	ASGI_2011_001		Non Converged Contingency	0	0.16596	9999	DBL-MEDLO-WI
FDNS	02G10_001		0 11G	G10_001	TO->FROM	FINNEY SWITCHING STATION - STEVENSCO 345.00 345KV CKT 1	1052	0.35277	110.1355	DBL-G0847-WO
FNSL-Blown up	02ALL		0 11G	G10_001		Non Converged Contingency	0	0.60735	9999	DBL-G0847-WO
FNSL-Blown up	03ALL		0 11G	G10_001		Non Converged Contingency	0	0.23317	9999	DBL-MEDLO-WI
FDNS	1		0 11G	G10_001	TO->FROM	NORTHWEST - TATONGA7 345.00 345KV CKT 1	1195	0.30574	108.9334	DBL-WOOD-MED
FDNS	1		0 11G	G10_001	TO->FROM	NORTHWEST - TATONGA7 345.00 345KV CKT 1	1195	0.26246	104.3674	DBL-MEDLO-WI
FDNS	1		2 11G	G10_001	TO->FROM	NORTHWEST - TATONGA7 345.00 345KV CKT 1	1195	0.24369	103.4627	DBL-MEDLO-WI
FDNS	1		3 11G	G10_001	TO->FROM	NORTHWEST - TATONGA7 345.00 345KV CKT 1	1195	0.24359	103.4056	DBL-MEDLO-WI
FDNS	1		2 11G	G10_001	TO->FROM	NORTHWEST - TATONGA7 345.00 345KV CKT 1	1195	0.24454	101.43	DBL-WOOD-MED
FDNS	1		3 11G	G10_001	TO->FROM	NORTHWEST - TATONGA7 345.00 345KV CKT 1	1195	0.24444	101.37	DBL-WOOD-MED
FDNS	2		0 11G	G10_012	TO->FROM	CLINTON JUNCTION - ELK CITY 138KV CKT 1	170	0.27365	112.8786	CLINTON AIR FORCE BASE TAP - ELK CITY 138KV CKT 1
FDNS	2		0 11G	G10_012	TO->FROM	CLINTON JUNCTION - ELK CITY 138KV CKT 1	170	0.27365	111.9207	CLINTON AIR FORCE BASE TAP - HOBART JUNCTION 138KV CKT 1
FDNS	2		2 11G	G10_012	TO->FROM	CLINTON JUNCTION - ELK CITY 138KV CKT 1	170	0.27274	110.6094	CLINTON AIR FORCE BASE TAP - ELK CITY 138KV CKT 1
FDNS	2		2 11G	G10_012	TO->FROM	CLINTON JUNCTION - ELK CITY 138KV CKT 1	170	0.27274	109.6555	CLINTON AIR FORCE BASE TAP - HOBART JUNCTION 138KV CKT 1
FDNS	2		0 11G	G10_012	TO->FROM	CLINTON JUNCTION - ELK CITY 138KV CKT 1	170	0.21329	108.5347	NORTHWEST - TATONGA7 345.00 345KV CKT 1
FDNS	2		0 11G	G10_012	TO->FROM	CLINTON JUNCTION - ELK CITY 138KV CKT 1	170	0.20934	107.9404	LAWTON EASTSIDE - OKLAUNION 345KV CKT 1
FDNS	2		2 11G	G10_012	TO->FROM	CLINTON JUNCTION - ELK CITY 138KV CKT 1	170	0.21217	105.386	NORTHWEST - TATONGA7 345.00 345KV CKT 1
FDNS	2		2 11G	G10_012	TO->FROM	CLINTON JUNCTION - ELK CITY 138KV CKT 1	170	0.20854	105.1823	LAWTON EASTSIDE - OKLAUNION 345KV CKT 1
FDNS	2		0 11G	G10_012	TO->FROM	CLINTON JUNCTION - ELK CITY 138KV CKT 1	170	0.20897	102.7288	DBL-G0847-WO
FDNS	2		0 11G	G10_012	TO->FROM	CLINTON JUNCTION - ELK CITY 138KV CKT 1	170	0.21329	102.607	G11-015T 345.00 - WWRDEHV7 345.00 345KV CKT 1
FDNS	2		0 11G	G10_012	TO->FROM	CLINTON JUNCTION - ELK CITY 138KV CKT 1	170	0.21329	102.5636	G11-015T 345.00 - TATONGA7 345.00 345KV CKT 1
FDNS	2		0 11G	G10_012	TO->FROM	CLINTON JUNCTION - ELK CITY 138KV CKT 1	170	0.21237	100.9172	DBL-MEDLO-WI
FNSL-Blown up	03ALL		0 11G	G10_012		Non Converged Contingency	0	0.12676	9999	DBL-MEDLO-WI
FNSL-Blown up	03ALL		0 11G	G10_041		Non Converged Contingency	1052	0.06303	67.17995	Hitchland Interchange - STEVENSCO 345.00 345KV CKT 1
FNSL-Blown up	03ALL		0 11G	G10_041		Non Converged Contingency	0	0.03944	9999	DBL-SPRVL-CO
FNSL-Blown up	03ALL		0 11G	G10_041		Non Converged Contingency	0	0.03944	9999	DBL-COM-MEDL
FNSL-Blown up	03ALL		0 11G	G10_041		Non Converged Contingency	1052	0.06303	59.28579	FINNEY SWITCHING STATION - STEVENSCO 345.00 345KV CKT 1
FNSL-Blown up	3		0 11G	G10_041		Non Converged Contingency	0	0.03993	9999	DBL-COM-MEDL
FDNS	13G10_041		0 11G	G10_041	FROM->TO	S1399 5 (FLTWTR TFMR) 161/34.5/13.8KV TRANSFORMER CKT 1	66	1	111.8854	G07-15T 161.00 - S1399 5 161KV CKT 1
FDNS	13G10_041		0 11G	G10_041	FROM->TO	S1399 5 (FLTWTR TFMR) 161/34.5/13.8KV TRANSFORMER CKT 1	66	1	111.6263	GEN560613 1-G07-15 0.5750

SOLUTION	GROUP	SCENARIO	SEASON	SOURCE	DIRECTION	MONITORED ELEMENT COMMON NAME	RATEB	TDF	TC%LOADING	CONTINGENCY NAME
FDNS	00G10_041	0	12SP	G10_041	FROM->TO	\$1399 5 (FLTWTR TFMR) 161/34.5/13.8KV TRANSFORMER CKT 1	66	1	106.8446	BASE CASE
FDNS	00G10_041	0	16SP	G10_041	FROM->TO	\$1399 5 (FLTWTR TFMR) 161/34.5/13.8KV TRANSFORMER CKT 1	66	1	106.8242	BASE CASE
FDNS	00G10_041	0	12WP	G10_041	FROM->TO	\$1399 5 (FLTWTR TFMR) 161/34.5/13.8KV TRANSFORMER CKT 1	66	1	106.0709	BASE CASE
FDNS	13G10_041	0	11G	G10_041	FROM->TO	\$1399 5 (FLTWTR TFMR) 161/34.5/13.8KV TRANSFORMER CKT 1	66	1	105.9648	BASE CASE
FDNS	00G10_041	0	16WP	G10_041	FROM->TO	\$1399 5 (FLTWTR TFMR) 161/34.5/13.8KV TRANSFORMER CKT 1	66	1	105.7742	BASE CASE
FDNS	00G10_043	2	16SP	G10_043	FROM->TO	FPL SWITCH - WOODWARD 138KV CKT 1	153	0.42934	134.1626	MOORELAND 345.00 (MRLNDAUTO) 345/138/13.8KV TRANSFORMER CKT 1
FDNS	00G10_043	0	16SP	G10_043	FROM->TO	FPL SWITCH - WOODWARD 138KV CKT 1	153	0.42736	134.1039	MOORELAND 345.00 (MRLNDAUTO) 345/138/13.8KV TRANSFORMER CKT 1
FDNS	00G10_043	2	16SP	G10_043	FROM->TO	FPL SWITCH - WOODWARD 138KV CKT 1	153	0.42934	134.0791	MOORELAND 345.00 - WWRDEHV7 345.00 345KV CKT 1
FDNS	00G10_043	0	16SP	G10_043	FROM->TO	FPL SWITCH - WOODWARD 138KV CKT 1	153	0.42736	134.0198	MOORELAND 345.00 - WWRDEHV7 345.00 345KV CKT 1
FDNS	00G10_043	0	12SP	G10_043	FROM->TO	FPL SWITCH - WOODWARD 138KV CKT 1	153	0.42747	128.1465	MOORELAND 345.00 (MRLNDAUTO) 345/138/13.8KV TRANSFORMER CKT 1
FDNS	00G10_043	0	12SP	G10_043	FROM->TO	FPL SWITCH - WOODWARD 138KV CKT 1	153	0.42747	128.0604	MOORELAND 345.00 - WWRDEHV7 345.00 345KV CKT 1
FDNS	00G10_043	2	12SP	G10_043	FROM->TO	FPL SWITCH - WOODWARD 138KV CKT 1	153	0.4295	127.8136	MOORELAND 345.00 (MRLNDAUTO) 345/138/13.8KV TRANSFORMER CKT 1
FDNS	00G10_043	2	12SP	G10_043	FROM->TO	FPL SWITCH - WOODWARD 138KV CKT 1	153	0.4295	127.7286	MOORELAND 345.00 - WWRDEHV7 345.00 345KV CKT 1
FDNS	00G10_043	2	12WP	G10_043	FROM->TO	FPL SWITCH - WOODWARD 138KV CKT 1	185	0.42833	114.136	MOORELAND 345.00 (MRLNDAUTO) 345/138/13.8KV TRANSFORMER CKT 1
FDNS	00G10_043	2	12WP	G10_043	FROM->TO	FPL SWITCH - WOODWARD 138KV CKT 1	185	0.42833	114.0743	MOORELAND 345.00 - WWRDEHV7 345.00 345KV CKT 1
FDNS	00G10_043	0	12WP	G10_043	FROM->TO	FPL SWITCH - WOODWARD 138KV CKT 1	185	0.42626	113.4515	MOORELAND 345.00 (MRLNDAUTO) 345/138/13.8KV TRANSFORMER CKT 1
FDNS	00G10_043	0	12WP	G10_043	FROM->TO	FPL SWITCH - WOODWARD 138KV CKT 1	185	0.42626	113.402	MOORELAND 345.00 - WWRDEHV7 345.00 345KV CKT 1
FDNS	00G10_043	2	16WP	G10_043	FROM->TO	FPL SWITCH - WOODWARD 138KV CKT 1	185	0.42852	112.8611	MOORELAND 345.00 (MRLNDAUTO) 345/138/13.8KV TRANSFORMER CKT 1
FDNS	00G10_043	2	16WP	G10_043	FROM->TO	FPL SWITCH - WOODWARD 138KV CKT 1	185	0.42852	112.8	MOORELAND 345.00 - WWRDEHV7 345.00 345KV CKT 1
FDNS	00G10_043	0	16WP	G10_043	FROM->TO	FPL SWITCH - WOODWARD 138KV CKT 1	185	0.4265	111.8915	MOORELAND 345.00 (MRLNDAUTO) 345/138/13.8KV TRANSFORMER CKT 1
FDNS	00G10_043	0	16WP	G10_043	FROM->TO	FPL SWITCH - WOODWARD 138KV CKT 1	185	0.4265	111.8296	MOORELAND 345.00 - WWRDEHV7 345.00 345KV CKT 1
FDNS	01G10_043	0	11G	G10_043	TO->FROM	NORTHWEST - TATONGA7 345.00 345KV CKT 1	1195	0.28414	119.5653	DBL-WOOD-MED
FDNS	01G10_043	0	11G	G10_043	TO->FROM	NORTHWEST - TATONGA7 345.00 345KV CKT 1	1195	0.23156	112.7964	DBL-MEDLO-WI
FDNS	01G10_043	2	11G	G10_043	TO->FROM	NORTHWEST - TATONGA7 345.00 345KV CKT 1	1195	0.22375	111.6178	DBL-MEDLO-WI
FDNS	01G10_043	3	11G	G10_043	TO->FROM	NORTHWEST - TATONGA7 345.00 345KV CKT 1	1195	0.22438	111.5917	DBL-MEDLO-WI
FDNS	01G10_043	2	11G	G10_043	TO->FROM	NORTHWEST - TATONGA7 345.00 345KV CKT 1	1195	0.24622	110.1709	DBL-WOOD-MED
FDNS	01G10_043	3	11G	G10_043	TO->FROM	NORTHWEST - TATONGA7 345.00 345KV CKT 1	1195	0.24687	110.1416	DBL-WOOD-MED
FNSL-Blown up	02ALL	0	11G	G10_045		Non Converged Contingency	0	0.06431	9999	DBL-G0847-WO
FNSL-Blown up	03ALL	0	11G	G10_045		Non Converged Contingency	1052	0.24089	67.17995	Hitchland Interchange - STEVENSCO 345.00 345KV CKT 1
FNSL-Blown up	03ALL	0	11G	G10_045		Non Converged Contingency	0	0.36728	9999	DBL-SPRVL-CO
FNSL-Blown up	03ALL	0	11G	G10_045		Non Converged Contingency	0	0.36728	9999	DBL-COM-MEDL
FNSL-Blown up	03ALL	0	11G	G10_045		Non Converged Contingency	0	0.25067	9999	DBL-MEDLO-WI
FNSL-Blown up	03ALL	0	11G	G10_045		Non Converged Contingency	1052	0.24089	59.28579	FINNEY SWITCHING STATION - STEVENSCO 345.00 345KV CKT 1
FNSL-Blown up	00G10_045	2	16SP	G10_045		Non Converged Contingency	0	0.03406	9999	TRF-STEGALL
FNSL-Blown up	00G10_045	2	16WP	G10_045		Non Converged Contingency	0	0.03363	9999	TRF-STEGALL
FNSL-Blown up	00G10_045	0	16SP	G10_045		Non Converged Contingency	0	0.0398	9999	TRF-STEGALL
FNSL-Blown up	00G10_045	0	16WP	G10_045		Non Converged Contingency	0	0.03935	9999	TRF-STEGALL
FNSL-Blown up	0	0	16SP	G10_045		Non Converged Contingency	0	0.03978	9999	TRF-STEGALL
FNSL-Blown up	0	0	16WP	G10_045		Non Converged Contingency	0	0.03939	9999	TRF-STEGALL
FNSL-Blown up	03G10_045	0	11G	G10_045		Non Converged Contingency	0	0.36759	9999	DBL-SPRVL-CO
FNSL-Blown up	03G10_045	0	11G	G10_045		Non Converged Contingency	0	0.36759	9999	DBL-COM-MEDL
FNSL-Blown up	03G10_045	0	11G	G10_045		Non Converged Contingency	0	0.25148	9999	DBL-MEDLO-WI
FNSL-Blown up	3	0	11G	G10_045		Non Converged Contingency	0	0.36777	9999	DBL-COM-MEDL
FNSL-Blown up	0	2	16SP	G10_045		Non Converged Contingency	0	0.03408	9999	TRF-STEGALL
FNSL-Blown up	0	2	16WP	G10_045		Non Converged Contingency	0	0.0337	9999	TRF-STEGALL
FNSL-Blown up	0	3	16SP	G10_045		Non Converged Contingency	0	0.03408	9999	TRF-STEGALL
FNSL-Blown up	0	3	16WP	G10_045		Non Converged Contingency	0	0.03369	9999	TRF-STEGALL
FNSL-Blown up	0	2	16SP	G10_045		Non Converged Contingency	0	0.03408	9999	TRF-STEGALL
FNSL-Blown up	0	2	16WP	G10_045		Non Converged Contingency	0	0.0337	9999	TRF-STEGALL
FDNS	00G10_047	0	16SP	G10_047	FROM->TO	G10-47T 115.00 - HARBINE 115KV CKT 1	99	0.3559	97.5	EAST MANHATTAN - JEFFREY ENERGY CENTER 230KV CKT 1
FDNS	00NR	0	16SP	G10_047	FROM->TO	G10-47T 115.00 - HARBINE 115KV CKT 1	99	0.3258	95	EAST MANHATTAN - JEFFREY ENERGY CENTER 230KV CKT 1
FDNS	00G10_047	0	16SP	G10_047	FROM->TO	G10-47T 115.00 - HARBINE 115KV CKT 1	99	0.42353	110.1002	BEATRICE POWER STATION - SHELDON 115KV CKT 1
FDNS	00NR	0	16SP	G10_047	FROM->TO	G10-47T 115.00 - HARBINE 115KV CKT 1	99	0.38182	108.1364	BEATRICE POWER STATION - SHELDON 115KV CKT 1
FDNS	00G10_047	0	12SP	G10_047	FROM->TO	G10-47T 115.00 - HARBINE 115KV CKT 1	99	0.42303	105.7763	BEATRICE POWER STATION - SHELDON 115KV CKT 1
FDNS	00G10_047	0	16SP	G10_047	FROM->TO	G10-47T 115.00 - HARBINE 115KV CKT 1	99	0.32203	104.4231	KELLY - SOUTH SENECA 115KV CKT 1
FDNS	00NR	0	12SP	G10_047	FROM->TO	G10-47T 115.00 - HARBINE 115KV CKT 1	99	0.37989	103.7165	BEATRICE POWER STATION - SHELDON 115KV CKT 1

SOLUTION	GROUP	SCENARIO	SEASON	SOURCE	DIRECTION	MONITORED ELEMENT COMMON NAME			RATEB	TDF	TC%LOADING	CONTINGENCY NAME
FDNS	00G10_047		0 16SP	G10_047	FROM->TO	G10-47T	115.00 - HARBINE	115KV CKT 1	99	0.33246	103.6039	CLIFTON - GREENLEAF 115KV CKT 1
FDNS	00G10_047		0 16SP	G10_047	FROM->TO	G10-47T	115.00 - HARBINE	115KV CKT 1	99	0.40013	103.2578	BEATRICE POWER STATION - CLATONIA 115KV CKT 1
FDNS	00NR		0 16SP	G10_047	FROM->TO	G10-47T	115.00 - HARBINE	115KV CKT 1	99	0.30688	102.5908	CLIFTON - GREENLEAF 115KV CKT 1
FDNS	00G10_047		0 16SP	G10_047	FROM->TO	G10-47T	115.00 - HARBINE	115KV CKT 1	99	0.40013	102.0636	CLATONIA - SHELDON 115KV CKT 1
FDNS	00G10_047		0 16SP	G10_047	FROM->TO	G10-47T	115.00 - HARBINE	115KV CKT 1	99	0.3488	101.5753	CONCORDIA - ELMCREK6 230.00 230KV CKT 1
FDNS	00G10_047		0 16SP	G10_047	FROM->TO	G10-47T	115.00 - HARBINE	115KV CKT 1	99	0.3488	101.5737	CONCORDIA (CONCORD6) 230/115/13.8KV TRANSFORMER CKT 1
FDNS	00NR		0 16SP	G10_047	FROM->TO	G10-47T	115.00 - HARBINE	115KV CKT 1	99	0.29557	101.4488	KELLY - SOUTH SENECA 115KV CKT 1
FDNS	00G10_047		0 16SP	G10_047	FROM->TO	G10-47T	115.00 - HARBINE	115KV CKT 1	99	0.35631	101.4265	GEN539655 1-CLIFTON GENERATOR
FDNS	00NR		0 16SP	G10_047	FROM->TO	G10-47T	115.00 - HARBINE	115KV CKT 1	99	0.36243	101.1177	BEATRICE POWER STATION - CLATONIA 115KV CKT 1
FDNS	00G10_047		0 16SP	G10_047	FROM->TO	G10-47T	115.00 - HARBINE	115KV CKT 1	99	0.33246	100.9879	GREENLEAF - KNOB HILL 115KV CKT 1
FDNS	00G10_047		0 16SP	G10_047	FROM->TO	G10-47T	115.00 - HARBINE	115KV CKT 1	99	0.35747	100.2606	CRETE - SHELDON 115KV CKT 1
FDNS	00NR		0 16SP	G10_047	FROM->TO	G10-47T	115.00 - HARBINE	115KV CKT 1	99	0.30688	100	GREENLEAF - KNOB HILL 115KV CKT 1
FNSL-Blown up	03ALL		0 11G	G10_047					1052	0.0775	67.17955	Hitchland Interchange - STEVENSCO 345.00 345KV CKT 1
FNSL-Blown up	03ALL		0 11G	G10_047					0	0.07096	9999	DBL-SPRVL-CO
FNSL-Blown up	03ALL		0 11G	G10_047					0	0.07096	9999	DBL-COM-MEDL
FNSL-Blown up	03ALL		0 11G	G10_047					1052	0.0775	59.28579	FINNEY SWITCHING STATION - STEVENSCO 345.00 345KV CKT 1
FNSL-Blown up	3		0 11G	G10_047					0	0.07145	9999	DBL-COM-MEDL
FNSL-Blown up	03ALL		0 11G	G10_048					1052	0.15226	67.17955	Hitchland Interchange - STEVENSCO 345.00 345KV CKT 1
FNSL-Blown up	03ALL		0 11G	G10_048					0	0.23703	9999	DBL-SPRVL-CO
FNSL-Blown up	03ALL		0 11G	G10_048					0	0.23703	9999	DBL-COM-MEDL
FNSL-Blown up	03ALL		0 11G	G10_048					0	0.12229	9999	DBL-MEDLO-WI
FNSL-Blown up	03ALL		0 11G	G10_048					1052	0.15226	59.28579	FINNEY SWITCHING STATION - STEVENSCO 345.00 345KV CKT 1
FNSL-Blown up	00G10_048		0 16SP	G10_048					0	0.04574	9999	TRF-STEGALL
FNSL-Blown up	00G10_048		0 16SP	G10_048					0	0.03049	9999	NEB01WAPAB3
FNSL-Blown up	00G10_048		0 16WP	G10_048					0	0.04534	9999	TRF-STEGALL
FNSL-Blown up	00G10_048		0 16WP	G10_048					0	0.03022	9999	NEB01WAPAB3
FNSL-Blown up	0		0 16SP	G10_048					0	0.04574	9999	TRF-STEGALL
FNSL-Blown up	0		0 16SP	G10_048					0	0.03005	9999	NEB01WAPAB3
FNSL-Blown up	0		0 16WP	G10_048					0	0.04535	9999	TRF-STEGALL
FNSL-Blown up	0		0 16WP	G10_048					0	0.03023	9999	NEB01WAPAB3
FNSL-Blown up	3		0 11G	G10_048					0	0.23752	9999	DBL-COM-MEDL
FNSL-Blown up	0		2 16SP	G10_048					0	0.04328	9999	TRF-STEGALL
FNSL-Blown up	0		2 16WP	G10_048					0	0.0429	9999	TRF-STEGALL
FNSL-Blown up	0		3 16SP	G10_048					0	0.04328	9999	TRF-STEGALL
FNSL-Blown up	0		3 16WP	G10_048					0	0.0429	9999	TRF-STEGALL
FNSL-Blown up	0		2 16SP	G10_048					0	0.04328	9999	TRF-STEGALL
FNSL-Blown up	0		2 16WP	G10_048					0	0.0429	9999	TRF-STEGALL
FDNS	03G10_049		0 11G	G10_049	TO->FROM	CLEARWATER - MILAN TAP	138KV CKT 1		110	0.20806	132.3219	MED-LDG5 345.00 345/138KV TRANSFORMER CKT 1
FDNS	03G10_049		2 11G	G10_049	TO->FROM	CLEARWATER - MILAN TAP	138KV CKT 1		110	0.20716	129.7706	MED-LDG5 345.00 345/138KV TRANSFORMER CKT 1
FDNS	3		0 11G	G10_049	TO->FROM	CLEARWATER - MILAN TAP	138KV CKT 1		110	0.20807	124.2815	MED-LDG5 345.00 345/138KV TRANSFORMER CKT 1
FDNS	3		2 11G	G10_049	TO->FROM	CLEARWATER - MILAN TAP	138KV CKT 1		110	0.20717	121.7931	MED-LDG5 345.00 345/138KV TRANSFORMER CKT 1
FDNS	03G10_049		0 11G	G10_049	FROM->TO	HARPER - MILAN TAP	138KV CKT 1		95.6	0.20806	166.8345	MED-LDG5 345.00 345/138KV TRANSFORMER CKT 1
FDNS	03G10_049		2 11G	G10_049	FROM->TO	HARPER - MILAN TAP	138KV CKT 1		95.6	0.20716	163.8387	MED-LDG5 345.00 345/138KV TRANSFORMER CKT 1
FDNS	3		0 11G	G10_049	FROM->TO	HARPER - MILAN TAP	138KV CKT 1		95.6	0.20807	157.5086	MED-LDG5 345.00 345/138KV TRANSFORMER CKT 1
FDNS	3		2 11G	G10_049	FROM->TO	HARPER - MILAN TAP	138KV CKT 1		95.6	0.20717	154.6231	MED-LDG5 345.00 345/138KV TRANSFORMER CKT 1
FDNS	03G10_049		2 11G	G10_049	FROM->TO	HUNTSVILLE - HUTCHINSON ENERGY CENTER	115KV CKT 1		68	0.22016	151.4837	CIRCLE - MULLERGREN 230KV CKT 1
FDNS	3		2 11G	G10_049	FROM->TO	HUNTSVILLE - HUTCHINSON ENERGY CENTER	115KV CKT 1		68	0.22016	138.4082	CIRCLE - MULLERGREN 230KV CKT 1
FDNS	3		0 11G	G10_049	FROM->TO	HUNTSVILLE - HUTCHINSON ENERGY CENTER	115KV CKT 1		92	0.22119	106.1099	CIRCLE - MULLERGREN 230KV CKT 1
FDNS	03G10_049		2 11G	G10_049	FROM->TO	HUNTSVILLE - HUTCHINSON ENERGY CENTER	115KV CKT 1		68	0.2191	178.8042	DBL-MEDLO-WI
FDNS	3		2 11G	G10_049	FROM->TO	HUNTSVILLE - HUTCHINSON ENERGY CENTER	115KV CKT 1		68	0.21911	165.6239	DBL-MEDLO-WI
FDNS	03G10_049		2 11G	G10_049	FROM->TO	HUNTSVILLE - HUTCHINSON ENERGY CENTER	115KV CKT 1		68	0.21371	144.0851	DBL-COM-MEDL
FDNS	03G10_049		2 11G	G10_049	FROM->TO	HUNTSVILLE - HUTCHINSON ENERGY CENTER	115KV CKT 1		68	0.28211	144.006	MEDICINE LODGE (MED-LDG4) 138/115/2.72KV TRANSFORMER CKT 1
FDNS	03G10_049		2 11G	G10_049	FROM->TO	HUNTSVILLE - HUTCHINSON ENERGY CENTER	115KV CKT 1		68	0.38945	139.3246	PRATT - SAWYER 3 115.00 115KV CKT 1
FDNS	03G10_049		2 11G	G10_049	FROM->TO	HUNTSVILLE - HUTCHINSON ENERGY CENTER	115KV CKT 1		68	0.38945	139.2898	MEDICINE LODGE - SAWYER 3 115.00 115KV CKT 1
FDNS	03G10_049		3 11G	G10_049	FROM->TO	HUNTSVILLE - HUTCHINSON ENERGY CENTER	115KV CKT 1		68	0.38943	139.0983	PRATT - SAWYER 3 115.00 115KV CKT 1
FDNS	03G10_049		3 11G	G10_049	FROM->TO	HUNTSVILLE - HUTCHINSON ENERGY CENTER	115KV CKT 1		68	0.38943	139.0644	MEDICINE LODGE - SAWYER 3 115.00 115KV CKT 1

SOLUTION	GROUP	SCENARIO	SEASON	SOURCE	DIRECTION	MONITORED ELEMENT COMMON NAME	RATEB	TDF	TC%LOADING	CONTINGENCY NAME
FDNS	03G10_049		2 11G	G10_049	FROM->TO	HUNTSVILLE - HUTCHINSON ENERGY CENTER 115KV CKT 1	68	0.39365	135.9719	SEWARD - ST JOHN 115KV CKT 1
FDNS	3		2 11G	G10_049	FROM->TO	HUNTSVILLE - HUTCHINSON ENERGY CENTER 115KV CKT 1	68	0.21372	130.5758	DBL-COM-MEDL
FDNS	03G10_049		2 11G	G10_049	FROM->TO	HUNTSVILLE - HUTCHINSON ENERGY CENTER 115KV CKT 1	68	0.21419	129.7287	MED-LDG5 345.00 - WICHITA 345KV CKT 1
FDNS	03G10_049		2 11G	G10_049	FROM->TO	HUNTSVILLE - HUTCHINSON ENERGY CENTER 115KV CKT 1	68	0.21419	129.7287	MED-LDG5 345.00 - WICHITA 345KV CKT 2
FDNS	03G10_049		2 11G	G10_049	FROM->TO	HUNTSVILLE - HUTCHINSON ENERGY CENTER 115KV CKT 1	68	0.21257	128.3761	CIRCLE (CIRCLE1X) 230/115/13.8KV TRANSFORMER CKT 1
FDNS	03G10_049		2 11G	G10_049	FROM->TO	HUNTSVILLE - HUTCHINSON ENERGY CENTER 115KV CKT 1	68	0.21342	127.5831	SMOKYHL6 230.00 - SUMMIT 230KV CKT 1
FDNS	3		2 11G	G10_049	FROM->TO	HUNTSVILLE - HUTCHINSON ENERGY CENTER 115KV CKT 1	68	0.28212	127.5447	MEDICINE LODGE (MED-LDG4) 138/115/2.72KV TRANSFORMER CKT 1
FDNS	03G10_049		2 11G	G10_049	FROM->TO	HUNTSVILLE - HUTCHINSON ENERGY CENTER 115KV CKT 1	68	0.21337	125.3947	NORTHWEST - TATONGA7 345.00 345KV CKT 1
FDNS	3		2 11G	G10_049	FROM->TO	HUNTSVILLE - HUTCHINSON ENERGY CENTER 115KV CKT 1	68	0.21372	124.9662	DBL-SPRVL-CO
FDNS	3		2 11G	G10_049	FROM->TO	HUNTSVILLE - HUTCHINSON ENERGY CENTER 115KV CKT 1	68	0.21372	124.9662	DBL-SPRVL-CO
FDNS	03G10_049		2 11G	G10_049	FROM->TO	HUNTSVILLE - HUTCHINSON ENERGY CENTER 115KV CKT 1	68	0.21264	124.2225	GEN532751 1-WOLF CREEK GENERATING STATION UNIT 1
FDNS	03G10_049		2 11G	G10_049	FROM->TO	HUNTSVILLE - HUTCHINSON ENERGY CENTER 115KV CKT 1	68	0.21342	123.9774	KNOLL 230 - SMOKYHL6 230.00 230KV CKT 1
FDNS	03G10_049		2 11G	G10_049	FROM->TO	HUNTSVILLE - HUTCHINSON ENERGY CENTER 115KV CKT 1	68	0.21337	122.5155	G11-015T 345.00 - WWRDEHV7 345.00 345KV CKT 1
FDNS	03G10_049		2 11G	G10_049	FROM->TO	HUNTSVILLE - HUTCHINSON ENERGY CENTER 115KV CKT 1	68	0.21337	122.4599	G11-015T 345.00 - TATONGA7 345.00 345KV CKT 1
FDNS	03G10_049		2 11G	G10_049	FROM->TO	HUNTSVILLE - HUTCHINSON ENERGY CENTER 115KV CKT 1	68	0.21421	121.9997	AXTELL - POSTROCK7 345.00 345KV CKT 1
FDNS	03G10_049		2 11G	G10_049	FROM->TO	HUNTSVILLE - HUTCHINSON ENERGY CENTER 115KV CKT 1	68	0.21287	121.4461	COMANCH5 345.00 - MED-LDG5 345.00 345KV CKT 1
FDNS	03G10_049		2 11G	G10_049	FROM->TO	HUNTSVILLE - HUTCHINSON ENERGY CENTER 115KV CKT 1	68	0.21287	121.4461	COMANCH5 345.00 - MED-LDG5 345.00 345KV CKT 2
FDNS	03G10_049		2 11G	G10_049	FROM->TO	HUNTSVILLE - HUTCHINSON ENERGY CENTER 115KV CKT 1	68	0.21343	121.2181	SPP-MKEC-08
FDNS	03G10_049		2 11G	G10_049	FROM->TO	HUNTSVILLE - HUTCHINSON ENERGY CENTER 115KV CKT 1	68	0.21264	121.1049	GEN532652 1-JEFFREY ENERGY CENTER UNIT 2
FDNS	03G10_049		2 11G	G10_049	FROM->TO	HUNTSVILLE - HUTCHINSON ENERGY CENTER 115KV CKT 1	68	0.21264	121.0099	GEN532653 1-JEFFREY ENERGY CENTER UNIT 3
FDNS	03G10_049		2 11G	G10_049	FROM->TO	HUNTSVILLE - HUTCHINSON ENERGY CENTER 115KV CKT 1	68	0.22822	120.1532	SEWARD - SEWRDMW3 115KV CKT 1
FDNS	03G10_049		2 11G	G10_049	FROM->TO	HUNTSVILLE - HUTCHINSON ENERGY CENTER 115KV CKT 1	68	0.22822	120.1426	SEWRDMW3 (SEWARD T1) 115/69/12.5KV TRANSFORMER CKT 1
FDNS	3		2 11G	G10_049	FROM->TO	HUNTSVILLE - HUTCHINSON ENERGY CENTER 115KV CKT 1	68	0.2142	117.0876	MED-LDG5 345.00 - WICHITA 345KV CKT 1
FDNS	3		2 11G	G10_049	FROM->TO	HUNTSVILLE - HUTCHINSON ENERGY CENTER 115KV CKT 1	68	0.2142	117.0876	MED-LDG5 345.00 - WICHITA 345KV CKT 2
FDNS	3		2 11G	G10_049	FROM->TO	HUNTSVILLE - HUTCHINSON ENERGY CENTER 115KV CKT 1	68	0.38945	116.5212	PRATT - SAWYER 3 115.00 115KV CKT 1
FDNS	3		2 11G	G10_049	FROM->TO	HUNTSVILLE - HUTCHINSON ENERGY CENTER 115KV CKT 1	68	0.38945	116.4895	MEDICINE LODGE - SAWYER 3 115.00 115KV CKT 1
FDNS	3		3 11G	G10_049	FROM->TO	HUNTSVILLE - HUTCHINSON ENERGY CENTER 115KV CKT 1	68	0.38944	116.2792	PRATT - SAWYER 3 115.00 115KV CKT 1
FDNS	3		3 11G	G10_049	FROM->TO	HUNTSVILLE - HUTCHINSON ENERGY CENTER 115KV CKT 1	68	0.38944	116.2483	MEDICINE LODGE - SAWYER 3 115.00 115KV CKT 1
FDNS	3		2 11G	G10_049	FROM->TO	HUNTSVILLE - HUTCHINSON ENERGY CENTER 115KV CKT 1	68	0.21258	115.8497	CIRCLE (CIRCLE1X) 230/115/13.8KV TRANSFORMER CKT 1
FDNS	03G10_049		3 11G	G10_049	FROM->TO	HUNTSVILLE - HUTCHINSON ENERGY CENTER 115KV CKT 1	68	0.21264	115.7937	MED-LDG5 345.00 345/115KV TRANSFORMER CKT 1
FDNS	03G10_049		2 11G	G10_049	FROM->TO	HUNTSVILLE - HUTCHINSON ENERGY CENTER 115KV CKT 1	68	0.21264	115.7791	BASE CASE
FDNS	3		2 11G	G10_049	FROM->TO	HUNTSVILLE - HUTCHINSON ENERGY CENTER 115KV CKT 1	68	0.21342	114.9448	SMOKYHL6 230.00 - SUMMIT 230KV CKT 1
FDNS	3		2 11G	G10_049	FROM->TO	HUNTSVILLE - HUTCHINSON ENERGY CENTER 115KV CKT 1	68	0.39366	113.0689	SEWARD - ST JOHN 115KV CKT 1
FDNS	3		2 11G	G10_049	FROM->TO	HUNTSVILLE - HUTCHINSON ENERGY CENTER 115KV CKT 1	68	0.21338	112.7332	NORTHWEST - TATONGA7 345.00 345KV CKT 1
FDNS	3		2 11G	G10_049	FROM->TO	HUNTSVILLE - HUTCHINSON ENERGY CENTER 115KV CKT 1	68	0.21265	112.0759	GEN532751 1-WOLF CREEK GENERATING STATION UNIT 1
FDNS	3		2 11G	G10_049	FROM->TO	HUNTSVILLE - HUTCHINSON ENERGY CENTER 115KV CKT 1	68	0.21342	111.3236	KNOLL 230 - SMOKYHL6 230.00 230KV CKT 1
FDNS	03G10_049		2 11G	G10_049	FROM->TO	HUNTSVILLE - HUTCHINSON ENERGY CENTER 115KV CKT 1	68	0.21224	111.0697	WRTOD400
FDNS	3		2 11G	G10_049	FROM->TO	HUNTSVILLE - HUTCHINSON ENERGY CENTER 115KV CKT 1	68	0.21338	109.9109	G11-015T 345.00 - WWRDEHV7 345.00 345KV CKT 1
FDNS	3		2 11G	G10_049	FROM->TO	HUNTSVILLE - HUTCHINSON ENERGY CENTER 115KV CKT 1	68	0.21338	109.866	G11-015T 345.00 - TATONGA7 345.00 345KV CKT 1
FDNS	03G10_049		2 11G	G10_049	FROM->TO	HUNTSVILLE - HUTCHINSON ENERGY CENTER 115KV CKT 1	68	0.21264	109.7927	GEN531447 1-HOLCOMB GENERATOR
FDNS	3		2 11G	G10_049	FROM->TO	HUNTSVILLE - HUTCHINSON ENERGY CENTER 115KV CKT 1	68	0.21275	109.3904	DBL-G0847-WO
FDNS	3		2 11G	G10_049	FROM->TO	HUNTSVILLE - HUTCHINSON ENERGY CENTER 115KV CKT 1	68	0.21422	109.3293	AXTELL - POSTROCK7 345.00 345KV CKT 1
FDNS	03G10_049		0 11G	G10_049	FROM->TO	HUNTSVILLE - HUTCHINSON ENERGY CENTER 115KV CKT 1	92	0.28329	109.0206	MEDICINE LODGE (MED-LDG4) 138/115/2.72KV TRANSFORMER CKT 1
FDNS	03G10_049		2 11G	G10_049	FROM->TO	HUNTSVILLE - HUTCHINSON ENERGY CENTER 115KV CKT 1	68	0.21264	108.8596	GEN560502 1-G01_039A 0.6000
FDNS	3		2 11G	G10_049	FROM->TO	HUNTSVILLE - HUTCHINSON ENERGY CENTER 115KV CKT 1	68	0.21288	108.791	COMANCH5 345.00 - MED-LDG5 345.00 345KV CKT 1
FDNS	3		2 11G	G10_049	FROM->TO	HUNTSVILLE - HUTCHINSON ENERGY CENTER 115KV CKT 1	68	0.21288	108.791	COMANCH5 345.00 - MED-LDG5 345.00 345KV CKT 2
FDNS	3		2 11G	G10_049	FROM->TO	HUNTSVILLE - HUTCHINSON ENERGY CENTER 115KV CKT 1	68	0.21265	108.7786	GEN532652 1-JEFFREY ENERGY CENTER UNIT 2
FDNS	3		2 11G	G10_049	FROM->TO	HUNTSVILLE - HUTCHINSON ENERGY CENTER 115KV CKT 1	68	0.21265	108.6804	GEN532653 1-JEFFREY ENERGY CENTER UNIT 3
FDNS	3		2 11G	G10_049	FROM->TO	HUNTSVILLE - HUTCHINSON ENERGY CENTER 115KV CKT 1	68	0.21343	108.6096	SPP-MKEC-08
FDNS	3		2 11G	G10_049	FROM->TO	HUNTSVILLE - HUTCHINSON ENERGY CENTER 115KV CKT 1	68	0.21265	108.4243	GEN532651 1-JEFFREY ENERGY CENTER UNIT 1
FDNS	03G10_049		2 11G	G10_049	FROM->TO	HUNTSVILLE - HUTCHINSON ENERGY CENTER 115KV CKT 1	68	0.21264	106.9511	GEN539677 3-A. M. MULLERGREN GENERATOR
FDNS	03G10_049		2 11G	G10_049	FROM->TO	HUNTSVILLE - HUTCHINSON ENERGY CENTER 115KV CKT 1	68	0.21535	105.5456	MULLERGREN - SPEARVILLE 230KV CKT 1
FDNS	3		3 11G	G10_049	FROM->TO	HUNTSVILLE - HUTCHINSON ENERGY CENTER 115KV CKT 1	68	0.21265	103.2802	MED-LDG5 345.00 345/115KV TRANSFORMER CKT 1
FDNS	3		2 11G	G10_049	FROM->TO	HUNTSVILLE - HUTCHINSON ENERGY CENTER 115KV CKT 1	68	0.21265	103.2758	BASE CASE
FDNS	03G10_049		2 11G	G10_049	FROM->TO	HUNTSVILLE - HUTCHINSON ENERGY CENTER 115KV CKT 1	68	0.21264	100.5616	GEN560342 1-G10-49 0.6900
FNLS	03G10_049		0 11G	G10_049	FROM->TO	HUNTSVILLE - HUTCHINSON ENERGY CENTER 115KV CKT 1	92	0.22118	115.8107	CIRCLE - MULLERGREN 230KV CKT 1

SOLUTION	GROUP	SCENARIO	SEASON	SOURCE	DIRECTION	MONITORED ELEMENT COMMON NAME	RATEB	TDF	TC%LOADING	CONTINGENCY NAME
FNSL	03G10_049		2 11G	G10_049	FROM->TO	HUNTSVILLE - HUTCHINSON ENERGY CENTER 115KV CKT 1	68	0.21371	138.8939	DBL-SPRVL-CO
FNSL	03G10_049		2 11G	G10_049	FROM->TO	HUNTSVILLE - HUTCHINSON ENERGY CENTER 115KV CKT 1	68	0.21274	122.0966	DBL-G0847-WO
FNSL	03G10_049		2 11G	G10_049	FROM->TO	HUNTSVILLE - HUTCHINSON ENERGY CENTER 115KV CKT 1	68	0.23189	102.8521	G01_039AT 115.00 - GREENSBURG 115KV CKT 1
FNSL	03G10_049		0 11G	G10_049	FROM->TO	HUNTSVILLE - HUTCHINSON ENERGY CENTER 115KV CKT 1	92	0.39018	102.6805	PRATT - SAWYER 3 115.00 115KV CKT 1
FNSL	03G10_049		0 11G	G10_049	FROM->TO	HUNTSVILLE - HUTCHINSON ENERGY CENTER 115KV CKT 1	92	0.39018	102.6566	MEDICINE LODGE - SAWYER 3 115.00 115KV CKT 1
FDNS	03G10_049		0 11G	G10_049	TO->FROM	HUNTSVILLE - ST_JOHN 115KV CKT 1	88	0.212	97.6	JEFFERY ENERGY CENTER - SUMMIT 345KV CKT 1
FDNS	03G10_049		2 11G	G10_049	TO->FROM	HUNTSVILLE - ST_JOHN 115KV CKT 1	88	0.2191	141.4706	DBL-MEDLO-WI
FDNS	3		2 11G	G10_049	TO->FROM	HUNTSVILLE - ST_JOHN 115KV CKT 1	88	0.21911	131.2793	DBL-MEDLO-WI
FDNS	03G10_049		2 11G	G10_049	TO->FROM	HUNTSVILLE - ST_JOHN 115KV CKT 1	88	0.22016	120.352	CIRCLE - MULLERGRENN 230KV CKT 1
FDNS	03G10_049		0 11G	G10_049	TO->FROM	HUNTSVILLE - ST_JOHN 115KV CKT 1	88	0.28329	117.2865	MEDICINE LODGE (MED-LDG4) 138/115/2.72KV TRANSFORMER CKT 1
FDNS	03G10_049		2 11G	G10_049	TO->FROM	HUNTSVILLE - ST_JOHN 115KV CKT 1	88	0.21371	114.6537	DBL-COM-MEDL
FDNS	03G10_049		2 11G	G10_049	TO->FROM	HUNTSVILLE - ST_JOHN 115KV CKT 1	88	0.28211	114.5802	MEDICINE LODGE (MED-LDG4) 138/115/2.72KV TRANSFORMER CKT 1
FDNS	3		0 11G	G10_049	TO->FROM	HUNTSVILLE - ST_JOHN 115KV CKT 1	88	0.22119	114.238	CIRCLE - MULLERGRENN 230KV CKT 1
FDNS	03G10_049		2 11G	G10_049	TO->FROM	HUNTSVILLE - ST_JOHN 115KV CKT 1	88	0.38945	110.969	PRATT - SAWYER 3 115.00 115KV CKT 1
FDNS	03G10_049		2 11G	G10_049	TO->FROM	HUNTSVILLE - ST_JOHN 115KV CKT 1	88	0.38945	110.9421	MEDICINE LODGE - SAWYER 3 115.00 115KV CKT 1
FDNS	03G10_049		3 11G	G10_049	TO->FROM	HUNTSVILLE - ST_JOHN 115KV CKT 1	88	0.38943	110.7972	PRATT - SAWYER 3 115.00 115KV CKT 1
FDNS	03G10_049		3 11G	G10_049	TO->FROM	HUNTSVILLE - ST_JOHN 115KV CKT 1	88	0.38943	110.7706	MEDICINE LODGE - SAWYER 3 115.00 115KV CKT 1
FDNS	3		2 11G	G10_049	TO->FROM	HUNTSVILLE - ST_JOHN 115KV CKT 1	88	0.22016	110.2532	CIRCLE - MULLERGRENN 230KV CKT 1
FDNS	03G10_049		2 11G	G10_049	TO->FROM	HUNTSVILLE - ST_JOHN 115KV CKT 1	88	0.39365	108.3878	SEWARD - ST JOHN 115KV CKT 1
FDNS	03G10_049		0 11G	G10_049	TO->FROM	HUNTSVILLE - ST_JOHN 115KV CKT 1	88	0.39378	105.7351	SEWARD - ST JOHN 115KV CKT 1
FDNS	03G10_049		0 11G	G10_049	TO->FROM	HUNTSVILLE - ST_JOHN 115KV CKT 1	88	0.2148	105.5926	MED-LDG5 345.00 - WICHITA 345KV CKT 1
FDNS	03G10_049		0 11G	G10_049	TO->FROM	HUNTSVILLE - ST_JOHN 115KV CKT 1	88	0.2148	105.5926	MED-LDG5 345.00 - WICHITA 345KV CKT 2
FDNS	03G10_049		0 11G	G10_049	TO->FROM	HUNTSVILLE - ST_JOHN 115KV CKT 1	88	0.21332	105.0569	CIRCLE (CIRCLE1X) 230/115/13.8KV TRANSFORMER CKT 1
FDNS	3		0 11G	G10_049	TO->FROM	HUNTSVILLE - ST_JOHN 115KV CKT 1	88	0.2833	104.3745	MEDICINE LODGE (MED-LDG4) 138/115/2.72KV TRANSFORMER CKT 1
FDNS	3		2 11G	G10_049	TO->FROM	HUNTSVILLE - ST_JOHN 115KV CKT 1	88	0.21372	104.2157	DBL-COM-MEDL
FDNS	03G10_049		0 11G	G10_049	TO->FROM	HUNTSVILLE - ST_JOHN 115KV CKT 1	88	0.21324	103.8342	BASE CASE
FDNS	03G10_049		2 11G	G10_049	TO->FROM	HUNTSVILLE - ST_JOHN 115KV CKT 1	88	0.21419	103.5652	MED-LDG5 345.00 - WICHITA 345KV CKT 1
FDNS	03G10_049		2 11G	G10_049	TO->FROM	HUNTSVILLE - ST_JOHN 115KV CKT 1	88	0.21419	103.5652	MED-LDG5 345.00 - WICHITA 345KV CKT 2
FDNS	03G10_049		2 11G	G10_049	TO->FROM	HUNTSVILLE - ST_JOHN 115KV CKT 1	88	0.21257	102.5093	CIRCLE (CIRCLE1X) 230/115/13.8KV TRANSFORMER CKT 1
FDNS	03G10_049		2 11G	G10_049	TO->FROM	HUNTSVILLE - ST_JOHN 115KV CKT 1	88	0.21264	102.0651	BASE CASE
FDNS	03G10_049		2 11G	G10_049	TO->FROM	HUNTSVILLE - ST_JOHN 115KV CKT 1	88	0.21342	101.9066	SMOKYHL6 230.00 - SUMMIT 230KV CKT 1
FDNS	3		2 11G	G10_049	TO->FROM	HUNTSVILLE - ST_JOHN 115KV CKT 1	88	0.28212	101.868	MEDICINE LODGE (MED-LDG4) 138/115/2.72KV TRANSFORMER CKT 1
FDNS	03G10_049		2 11G	G10_049	TO->FROM	HUNTSVILLE - ST_JOHN 115KV CKT 1	88	0.21337	100.2211	NORTHWEST - TATONGA7 345.00 345KV CKT 1
FNSL	03G10_049		0 11G	G10_049	TO->FROM	HUNTSVILLE - ST_JOHN 115KV CKT 1	88	0.22118	124.3754	CIRCLE - MULLERGRENN 230KV CKT 1
FNSL	03G10_049		0 11G	G10_049	TO->FROM	HUNTSVILLE - ST_JOHN 115KV CKT 1	88	0.39018	110.6638	PRATT - SAWYER 3 115.00 115KV CKT 1
FNSL	03G10_049		0 11G	G10_049	TO->FROM	HUNTSVILLE - ST_JOHN 115KV CKT 1	88	0.39018	110.6385	MEDICINE LODGE - SAWYER 3 115.00 115KV CKT 1
FNSL	03G10_049		2 11G	G10_049	TO->FROM	HUNTSVILLE - ST_JOHN 115KV CKT 1	88	0.21371	110.6312	DBL-SPRVL-CO
FNSL	03G10_049		0 11G	G10_049	TO->FROM	HUNTSVILLE - ST_JOHN 115KV CKT 1	88	0.21444	105.2321	Hitchland Interchange - STEVENSCO 345.00 345KV CKT 1
FNSL	03G10_049		0 11G	G10_049	TO->FROM	HUNTSVILLE - ST_JOHN 115KV CKT 1	88	0.21413	104.4571	SMOKYHL6 230.00 - SUMMIT 230KV CKT 1
FNSL	03G10_049		0 11G	G10_049	TO->FROM	HUNTSVILLE - ST_JOHN 115KV CKT 1	88	0.21444	102.2594	FINNEY SWITCHING STATION - STEVENSCO 345.00 345KV CKT 1
FNSL	03G10_049		0 11G	G10_049	TO->FROM	HUNTSVILLE - ST_JOHN 115KV CKT 1	88	0.21413	101.5859	KNOLL 230 - SMOKYHL6 230.00 230KV CKT 1
FNSL	03G10_049		0 11G	G10_049	TO->FROM	HUNTSVILLE - ST_JOHN 115KV CKT 1	88	0.21383	101.0022	NORTHWEST - TATONGA7 345.00 345KV CKT 1
FNSL	03G10_049		0 11G	G10_049	TO->FROM	HUNTSVILLE - ST_JOHN 115KV CKT 1	88	0.21324	100.9953	GEN532751 1-WOLF CREEK GENERATING STATION UNIT 1
FNSL	03G10_049		0 11G	G10_049	TO->FROM	HUNTSVILLE - ST_JOHN 115KV CKT 1	88	0.21364	100.8332	COMANCH5 345.00 - MED-LDG5 345.00 345KV CKT 1
FNSL	03G10_049		0 11G	G10_049	TO->FROM	HUNTSVILLE - ST_JOHN 115KV CKT 1	88	0.21364	100.8332	COMANCH5 345.00 - MED-LDG5 345.00 345KV CKT 2
FNSL	03G10_049		0 11G	G10_049	TO->FROM	HUNTSVILLE - ST_JOHN 115KV CKT 1	88	0.21493	100.078	AXTELL - POSTROCK7 345.00 345KV CKT 1
FNSL-Blown up	03ALL		2 11G	G10_049		Non Converged Contingency	198	0.54044	89.82827	NINNES3 115.00 - PRATT 115KV CKT 1
FNSL-Blown up	03ALL		2 11G	G10_049		Non Converged Contingency	198	0.54044	87.37672	NINNES3 115.00 - ST JOHN 115KV CKT 1
FNSL-Blown up	03ALL		0 11G	G10_049		Non Converged Contingency	1052	0.08811	67.17995	Hitchland Interchange - STEVENSCO 345.00 345KV CKT 1
FNSL-Blown up	03ALL		0 11G	G10_049		Non Converged Contingency	198	0.54026	86.63963	NINNES3 115.00 - PRATT 115KV CKT 1
FNSL-Blown up	03ALL		0 11G	G10_049		Non Converged Contingency	198	0.54026	84.16129	NINNES3 115.00 - ST JOHN 115KV CKT 1
FNSL-Blown up	03ALL		0 11G	G10_049		Non Converged Contingency	0	0.09073	9999	DBL-SPRVL-CO
FNSL-Blown up	03ALL		0 11G	G10_049		Non Converged Contingency	0	0.09073	9999	DBL-COM-MEDL
FNSL-Blown up	03ALL		0 11G	G10_049		Non Converged Contingency	0	0.18103	9999	DBL-MEDLO-WI
FNSL-Blown up	03ALL		0 11G	G10_049		Non Converged Contingency	1052	0.08811	59.28579	FINNEY SWITCHING STATION - STEVENSCO 345.00 345KV CKT 1
FNSL-Blown up	03G10_049		2 11G	G10_049		Non Converged Contingency	198	0.54046	83.00513	NINNES3 115.00 - ST JOHN 115KV CKT 1

SOLUTION	GROUP	SCENARIO	SEASON	SOURCE	DIRECTION	MONITORED ELEMENT COMMON NAME	RATEB	TDF	TC%LOADING	CONTINGENCY NAME
FNSL-Blown up	03G10_049	0	11G	G10_049		Non Converged Contingency	198	0.54028	82.1059	NINNES3 115.00 - PRATT 115KV CKT 1
FNSL-Blown up	03G10_049	0	11G	G10_049		Non Converged Contingency	0	0.09113	9999	DBL-COM-MEDL
FNSL-Blown up	03G10_049	0	11G	G10_049		Non Converged Contingency	0	0.18197	9999	DBL-MEDLO-WI
FNSL-Blown up	3	0	11G	G10_049		Non Converged Contingency	0	0.09122	9999	DBL-COM-MEDL
FDNS	03G10_049	2	11G	G10_049	TO->FROM	SEWARD - ST JOHN 115KV CKT 1	79.7	0.4689	100.8667	HUNTSVILLE - ST JOHN 115KV CKT 1
FDNS	03G10_049	2	11G	G10_049	TO->FROM	SEWARD - ST JOHN 115KV CKT 1	79.7	0.4689	100.8524	MIDW-CATB05
FDNS	006G10_049	2	12SP	G10_049	FROM->TO	ST JOHN - ST JOHN 115KV CKT 1	86	0.389	112.2439	MEDICINE LODGE - SAWYER 3 115.00 115KV CKT 1
FDNS	03G10_049	2	11G	G10_049	FROM->TO	ST JOHN - ST JOHN 115KV CKT 1	86	0.2191	180.0158	DBL-MEDLO-WI
FDNS	3	2	11G	G10_049	FROM->TO	ST JOHN - ST JOHN 115KV CKT 1	86	0.21911	169.1153	DBL-MEDLO-WI
FDNS	03G10_049	2	11G	G10_049	FROM->TO	ST JOHN - ST JOHN 115KV CKT 1	86	0.22016	157.5854	CIRCLE - MULLERGREEN 230KV CKT 1
FDNS	03G10_049	0	11G	G10_049	FROM->TO	ST JOHN - ST JOHN 115KV CKT 1	86	0.28329	154.7524	MEDICINE LODGE (MED-LDG4) 138/115/2.72KV TRANSFORMER CKT 1
FDNS	03G10_049	2	11G	G10_049	FROM->TO	ST JOHN - ST JOHN 115KV CKT 1	86	0.28211	151.7776	MEDICINE LODGE (MED-LDG4) 138/115/2.72KV TRANSFORMER CKT 1
FDNS	03G10_049	2	11G	G10_049	FROM->TO	ST JOHN - ST JOHN 115KV CKT 1	86	0.21371	151.668	DBL-COM-MEDL
FDNS	3	0	11G	G10_049	FROM->TO	ST JOHN - ST JOHN 115KV CKT 1	86	0.22119	151.2848	CIRCLE - MULLERGREEN 230KV CKT 1
FDNS	03G10_049	2	11G	G10_049	FROM->TO	ST JOHN - ST JOHN 115KV CKT 1	86	0.38945	148.0029	PRATT - SAWYER 3 115.00 115KV CKT 1
FDNS	03G10_049	2	11G	G10_049	FROM->TO	ST JOHN - ST JOHN 115KV CKT 1	86	0.38945	147.9718	MEDICINE LODGE - SAWYER 3 115.00 115KV CKT 1
FDNS	3	2	11G	G10_049	FROM->TO	ST JOHN - ST JOHN 115KV CKT 1	86	0.22016	146.9839	CIRCLE - MULLERGREEN 230KV CKT 1
FDNS	03G10_049	2	11G	G10_049	FROM->TO	ST JOHN - ST JOHN 115KV CKT 1	86	0.39365	145.3062	SEWARD - ST JOHN 115KV CKT 1
FDNS	03G10_049	0	11G	G10_049	FROM->TO	ST JOHN - ST JOHN 115KV CKT 1	86	0.39378	142.6674	SEWARD - ST JOHN 115KV CKT 1
FDNS	03G10_049	0	11G	G10_049	FROM->TO	ST JOHN - ST JOHN 115KV CKT 1	86	0.2148	142.4628	MED-LDG5 345.00 - WICHITA 345KV CKT 1
FDNS	03G10_049	0	11G	G10_049	FROM->TO	ST JOHN - ST JOHN 115KV CKT 1	86	0.2148	142.4628	MED-LDG5 345.00 - WICHITA 345KV CKT 2
FDNS	03G10_049	0	11G	G10_049	FROM->TO	ST JOHN - ST JOHN 115KV CKT 1	86	0.21332	141.7548	CIRCLE (CIRCLE1X) 230/115/13.8KV TRANSFORMER CKT 1
FDNS	3	0	11G	G10_049	FROM->TO	ST JOHN - ST JOHN 115KV CKT 1	86	0.2833	141.1358	MEDICINE LODGE (MED-LDG4) 138/115/2.72KV TRANSFORMER CKT 1
FDNS	3	2	11G	G10_049	FROM->TO	ST JOHN - ST JOHN 115KV CKT 1	86	0.21372	140.5582	DBL-COM-MEDL
FDNS	03G10_049	2	11G	G10_049	FROM->TO	ST JOHN - ST JOHN 115KV CKT 1	86	0.21419	140.4053	MED-LDG5 345.00 - WICHITA 345KV CKT 1
FDNS	03G10_049	2	11G	G10_049	FROM->TO	ST JOHN - ST JOHN 115KV CKT 1	86	0.21419	140.4053	MED-LDG5 345.00 - WICHITA 345KV CKT 2
FDNS	03G10_049	2	11G	G10_049	FROM->TO	ST JOHN - ST JOHN 115KV CKT 1	86	0.21257	138.9723	CIRCLE (CIRCLE1X) 230/115/13.8KV TRANSFORMER CKT 1
FDNS	03G10_049	2	11G	G10_049	FROM->TO	ST JOHN - ST JOHN 115KV CKT 1	86	0.21342	138.615	SMOKYHL6 230.00 - SUMMIT 230KV CKT 1
FDNS	3	2	11G	G10_049	FROM->TO	ST JOHN - ST JOHN 115KV CKT 1	86	0.28212	138.4121	MEDICINE LODGE (MED-LDG4) 138/115/2.72KV TRANSFORMER CKT 1
FDNS	03G10_049	2	11G	G10_049	FROM->TO	ST JOHN - ST JOHN 115KV CKT 1	86	0.21337	136.9683	NORTHWEST - TATONGA7 345.00 345KV CKT 1
FDNS	3	2	11G	G10_049	FROM->TO	ST JOHN - ST JOHN 115KV CKT 1	86	0.21372	136.0114	DBL-SPRVL-CO
FDNS	3	2	11G	G10_049	FROM->TO	ST JOHN - ST JOHN 115KV CKT 1	86	0.21372	136.0114	DBL-SPRVL-CO
FDNS	03G10_049	2	11G	G10_049	FROM->TO	ST JOHN - ST JOHN 115KV CKT 1	86	0.21264	135.9547	GEN532751 1-WOLF CREEK GENERATING STATION UNIT 1
FDNS	03G10_049	2	11G	G10_049	FROM->TO	ST JOHN - ST JOHN 115KV CKT 1	86	0.21342	135.632	KNOLL 230 - SMOKYHL6 230.00 230KV CKT 1
FDNS	03G10_049	0	11G	G10_049	FROM->TO	ST JOHN - ST JOHN 115KV CKT 1	86	0.21383	135.5022	G11-015T 345.00 - WWRDEHV7 345.00 345KV CKT 1
FDNS	03G10_049	0	11G	G10_049	FROM->TO	ST JOHN - ST JOHN 115KV CKT 1	86	0.21383	135.4607	G11-015T 345.00 - TATONGA7 345.00 345KV CKT 1
FDNS	03G10_049	0	11G	G10_049	FROM->TO	ST JOHN - ST JOHN 115KV CKT 1	86	0.21324	134.9636	GEN532652 1-JEFFREY ENERGY CENTER UNIT 2
FDNS	03G10_049	0	11G	G10_049	FROM->TO	ST JOHN - ST JOHN 115KV CKT 1	86	0.21324	134.887	GEN532653 1-JEFFREY ENERGY CENTER UNIT 3
FDNS	03G10_049	0	11G	G10_049	FROM->TO	ST JOHN - ST JOHN 115KV CKT 1	86	0.21348	134.8426	KNOLL 230 - POSTROCK6 230.00 230KV CKT 1
FDNS	03G10_049	2	11G	G10_049	FROM->TO	ST JOHN - ST JOHN 115KV CKT 1	86	0.21337	134.5367	G11-015T 345.00 - WWRDEHV7 345.00 345KV CKT 1
FDNS	03G10_049	2	11G	G10_049	FROM->TO	ST JOHN - ST JOHN 115KV CKT 1	86	0.21337	134.4888	G11-015T 345.00 - TATONGA7 345.00 345KV CKT 1
FDNS	03G10_049	2	11G	G10_049	FROM->TO	ST JOHN - ST JOHN 115KV CKT 1	86	0.21421	134.0908	AXTELL - POSTROCK7 345.00 345KV CKT 1
FDNS	03G10_049	0	11G	G10_049	FROM->TO	ST JOHN - ST JOHN 115KV CKT 1	86	0.22876	133.8048	SEWRDMW3 (SEWARD T1) 115/69/12.5KV TRANSFORMER CKT 1
FDNS	03G10_049	0	11G	G10_049	FROM->TO	ST JOHN - ST JOHN 115KV CKT 1	86	0.22876	133.7812	SEWARD - SEWRDMW3 115KV CKT 1
FDNS	03G10_049	2	11G	G10_049	FROM->TO	ST JOHN - ST JOHN 115KV CKT 1	86	0.21287	133.6691	COMANCH5 345.00 - MED-LDG5 345.00 345KV CKT 1
FDNS	03G10_049	2	11G	G10_049	FROM->TO	ST JOHN - ST JOHN 115KV CKT 1	86	0.21287	133.6691	COMANCH5 345.00 - MED-LDG5 345.00 345KV CKT 2
FDNS	03G10_049	2	11G	G10_049	FROM->TO	ST JOHN - ST JOHN 115KV CKT 1	86	0.21343	133.4318	SPP-MKEEC-08
FDNS	03G10_049	2	11G	G10_049	FROM->TO	ST JOHN - ST JOHN 115KV CKT 1	86	0.21264	133.2996	GEN532652 1-JEFFREY ENERGY CENTER UNIT 2
FDNS	03G10_049	2	11G	G10_049	FROM->TO	ST JOHN - ST JOHN 115KV CKT 1	86	0.21264	133.221	GEN532653 1-JEFFREY ENERGY CENTER UNIT 3
FDNS	03G10_049	2	11G	G10_049	FROM->TO	ST JOHN - ST JOHN 115KV CKT 1	86	0.21264	133.0242	GEN532651 1-JEFFREY ENERGY CENTER UNIT 1
FDNS	03G10_049	2	11G	G10_049	FROM->TO	ST JOHN - ST JOHN 115KV CKT 1	86	0.22822	132.4146	SEWARD - SEWRDMW3 115KV CKT 1
FDNS	03G10_049	2	11G	G10_049	FROM->TO	ST JOHN - ST JOHN 115KV CKT 1	86	0.22822	132.4043	SEWRDMW3 (SEWARD T1) 115/69/12.5KV TRANSFORMER CKT 1
FDNS	3	0	11G	G10_049	FROM->TO	ST JOHN - ST JOHN 115KV CKT 1	86	0.21481	132.1483	MED-LDG5 345.00 - WICHITA 345KV CKT 1
FDNS	3	0	11G	G10_049	FROM->TO	ST JOHN - ST JOHN 115KV CKT 1	86	0.21481	132.1483	MED-LDG5 345.00 - WICHITA 345KV CKT 2
FDNS	3	0	11G	G10_049	FROM->TO	ST JOHN - ST JOHN 115KV CKT 1	86	0.21333	131.448	CIRCLE (CIRCLE1X) 230/115/13.8KV TRANSFORMER CKT 1
FDNS	03G10_049	0	11G	G10_049	FROM->TO	ST JOHN - ST JOHN 115KV CKT 1	86	0.21324	130.7533	BASE CASE

SOLUTION	GROUP	SCENARIO	SEASON	SOURCE	DIRECTION	MONITORED ELEMENT COMMON NAME	RATEB	TDF	TC%LOADING	CONTINGENCY NAME
FDNS	3		2 11G	G10_049	FROM->TO	ST JOHN - ST_JOHN 115KV CKT 1	86	0.2142	130.1685	MED-LDG5 345.00 - WICHITA 345KV CKT 1
FDNS	3		2 11G	G10_049	FROM->TO	ST JOHN - ST_JOHN 115KV CKT 1	86	0.2142	130.1685	MED-LDG5 345.00 - WICHITA 345KV CKT 2
FDNS	3		2 11G	G10_049	FROM->TO	ST JOHN - ST_JOHN 115KV CKT 1	86	0.38945	129.498	PRATT - SAWYER 3 115.00 115KV CKT 1
FDNS	3		2 11G	G10_049	FROM->TO	ST JOHN - ST_JOHN 115KV CKT 1	86	0.38945	129.4707	MEDICINE LODGE - SAWYER 3 115.00 115KV CKT 1
FDNS	03G10_049		2 11G	G10_049	FROM->TO	ST JOHN - ST_JOHN 115KV CKT 1	86	0.21264	128.9299	BASE CASE
FDNS	3		2 11G	G10_049	FROM->TO	ST JOHN - ST_JOHN 115KV CKT 1	86	0.21258	128.8266	CIRCLE (CIRCLE1X) 230/115/13.8KV TRANSFORMER CKT 1
FDNS	3		2 11G	G10_049	FROM->TO	ST JOHN - ST_JOHN 115KV CKT 1	86	0.21342	128.3896	SMOKYHL6 230.00 - SUMMIT 230KV CKT 1
FDNS	3		0 11G	G10_049	FROM->TO	ST JOHN - ST_JOHN 115KV CKT 1	86	0.21414	127.9462	KNOLL 230 - SMOKYHL6 230.00 230KV CKT 1
FDNS	3		0 11G	G10_049	FROM->TO	ST JOHN - ST_JOHN 115KV CKT 1	86	0.21384	127.4005	NORTHWEST - TATONGA7 345.00 345KV CKT 1
FDNS	03G10_049		0 11G	G10_049	FROM->TO	ST JOHN - ST_JOHN 115KV CKT 1	86	0.21284	127.0191	WRTOD400
FDNS	3		2 11G	G10_049	FROM->TO	ST JOHN - ST_JOHN 115KV CKT 1	86	0.39366	126.7269	SEWARD - ST JOHN 115KV CKT 1
FDNS	3		2 11G	G10_049	FROM->TO	ST JOHN - ST_JOHN 115KV CKT 1	86	0.21338	126.7114	NORTHWEST - TATONGA7 345.00 345KV CKT 1
FDNS	03G10_049		0 11G	G10_049	FROM->TO	ST JOHN - ST_JOHN 115KV CKT 1	86	0.21324	126.5847	GEN560279 1-G08-18 0.6900
FDNS	3		0 11G	G10_049	FROM->TO	ST JOHN - ST_JOHN 115KV CKT 1	86	0.21494	126.2333	AXTELL - POSTROCK7 345.00 345KV CKT 1
FDNS	03G10_049		0 11G	G10_049	FROM->TO	ST JOHN - ST_JOHN 115KV CKT 1	86	0.21324	126.2028	GEN539670 4-JUDSON LARGE GENERATOR
FDNS	3		2 11G	G10_049	FROM->TO	ST JOHN - ST_JOHN 115KV CKT 1	86	0.21265	126.124	GEN532751 1-WOLF CREEK GENERATING STATION UNIT 1
FDNS	03G10_049		0 11G	G10_049	FROM->TO	ST JOHN - ST_JOHN 115KV CKT 1	86	0.21382	126.1002	GRAY CO 345.00 - SPEARVILLE 345KV CKT 1
FDNS	3		2 11G	G10_049	FROM->TO	ST JOHN - ST_JOHN 115KV CKT 1	86	0.21342	125.3927	KNOLL 230 - SMOKYHL6 230.00 230KV CKT 1
FDNS	03G10_049		2 11G	G10_049	FROM->TO	ST JOHN - ST_JOHN 115KV CKT 1	86	0.21224	125.1875	WRTOD400
FDNS	3		0 11G	G10_049	FROM->TO	ST JOHN - ST_JOHN 115KV CKT 1	86	0.21384	125.1699	G11-015T 345.00 - WWRDEHV7 345.00 345KV CKT 1
FDNS	3		0 11G	G10_049	FROM->TO	ST JOHN - ST_JOHN 115KV CKT 1	86	0.21384	125.1311	G11-015T 345.00 - TATONGA7 345.00 345KV CKT 1
FDNS	03G10_049		0 11G	G10_049	FROM->TO	ST JOHN - ST_JOHN 115KV CKT 1	86	0.21324	125.008	GEN531447 1-HOLCOMB GENERATOR
FDNS	3		0 11G	G10_049	FROM->TO	ST JOHN - ST_JOHN 115KV CKT 1	86	0.21325	124.8426	GEN532652 1-JEFFREY ENERGY CENTER UNIT 2
FDNS	3		0 11G	G10_049	FROM->TO	ST JOHN - ST_JOHN 115KV CKT 1	86	0.21325	124.7636	GEN532653 1-JEFFREY ENERGY CENTER UNIT 3
FDNS	3		0 11G	G10_049	FROM->TO	ST JOHN - ST_JOHN 115KV CKT 1	86	0.21325	124.5572	GEN532651 1-JEFFREY ENERGY CENTER UNIT 1
FDNS	3		0 11G	G10_049	FROM->TO	ST JOHN - ST_JOHN 115KV CKT 1	86	0.21349	124.5195	KNOLL 230 - POSTROCK6 230.00 230KV CKT 1
FDNS	3		0 11G	G10_049	FROM->TO	ST JOHN - ST_JOHN 115KV CKT 1	86	0.21325	124.3898	GEN336821 1-GRAND GULF UNIT
FDNS	3		2 11G	G10_049	FROM->TO	ST JOHN - ST_JOHN 115KV CKT 1	86	0.21338	124.3467	G11-015T 345.00 - WWRDEHV7 345.00 345KV CKT 1
FDNS	3		2 11G	G10_049	FROM->TO	ST JOHN - ST_JOHN 115KV CKT 1	86	0.21338	124.3068	G11-015T 345.00 - TATONGA7 345.00 345KV CKT 1
FDNS	03G10_049		2 11G	G10_049	FROM->TO	ST JOHN - ST_JOHN 115KV CKT 1	86	0.21264	123.9773	GEN531447 1-HOLCOMB GENERATOR
FDNS	3		2 11G	G10_049	FROM->TO	ST JOHN - ST_JOHN 115KV CKT 1	86	0.21275	123.9368	DBL-G0847-WO
FDNS	3		2 11G	G10_049	FROM->TO	ST JOHN - ST_JOHN 115KV CKT 1	86	0.21422	123.8466	AXTELL - POSTROCK7 345.00 345KV CKT 1
FDNS	03G10_049		0 11G	G10_049	FROM->TO	ST JOHN - ST_JOHN 115KV CKT 1	86	0.21324	123.5105	GEN539677 3-A. M. MULLERGREN GENERATOR
FDNS	3		2 11G	G10_049	FROM->TO	ST JOHN - ST_JOHN 115KV CKT 1	86	0.21288	123.4311	COMANCH5 345.00 - MED-LDG5 345.00 345KV CKT 1
FDNS	3		2 11G	G10_049	FROM->TO	ST JOHN - ST_JOHN 115KV CKT 1	86	0.21288	123.4311	COMANCH5 345.00 - MED-LDG5 345.00 345KV CKT 2
FDNS	3		2 11G	G10_049	FROM->TO	ST JOHN - ST_JOHN 115KV CKT 1	86	0.21265	123.3349	GEN532652 1-JEFFREY ENERGY CENTER UNIT 2
FDNS	03G10_049		2 11G	G10_049	FROM->TO	ST JOHN - ST_JOHN 115KV CKT 1	86	0.21264	123.3013	GEN560502 1-G01_039A 0.6000
FDNS	3		2 11G	G10_049	FROM->TO	ST JOHN - ST_JOHN 115KV CKT 1	86	0.21265	123.2538	GEN532653 1-JEFFREY ENERGY CENTER UNIT 3
FDNS	3		2 11G	G10_049	FROM->TO	ST JOHN - ST_JOHN 115KV CKT 1	86	0.21343	123.2353	SPP-MKEC-08
FDNS	3		2 11G	G10_049	FROM->TO	ST JOHN - ST_JOHN 115KV CKT 1	86	0.21265	123.0605	GEN532651 1-JEFFREY ENERGY CENTER UNIT 1
FDNS	3		2 11G	G10_049	FROM->TO	ST JOHN - ST_JOHN 115KV CKT 1	86	0.21265	122.8529	GEN336821 1-GRAND GULF UNIT
FDNS	03G10_049		2 11G	G10_049	FROM->TO	ST JOHN - ST_JOHN 115KV CKT 1	86	0.21264	121.8752	GEN539677 3-A. M. MULLERGREN GENERATOR
FDNS	03G10_049		2 11G	G10_049	FROM->TO	ST JOHN - ST_JOHN 115KV CKT 1	86	0.21535	120.5648	MULLERGREN - SPEARVILLE 230KV CKT 1
FDNS	3		0 11G	G10_049	FROM->TO	ST JOHN - ST_JOHN 115KV CKT 1	86	0.21325	120.4962	BASE CASE
FDNS	3		2 11G	G10_049	FROM->TO	ST JOHN - ST_JOHN 115KV CKT 1	86	0.21265	118.8322	BASE CASE
FDNS	03G10_049		0 11G	G10_049	FROM->TO	ST JOHN - ST_JOHN 115KV CKT 1	86	0.21324	118.3424	GEN560342 1-G10-49 0.6900
FDNS	3		0 11G	G10_049	FROM->TO	ST JOHN - ST_JOHN 115KV CKT 1	86	0.29311	118.0408	GREAT BEND TAP - SEWARD 115KV CKT 1
FDNS	3		0 11G	G10_049	FROM->TO	ST JOHN - ST_JOHN 115KV CKT 1	86	0.29311	117.982	GREAT BEND TAP - MULLERGREN 115KV CKT 1
FDNS	3		0 11G	G10_049	FROM->TO	ST JOHN - ST_JOHN 115KV CKT 1	86	0.21285	116.7828	WRTOD400
FDNS	03G10_049		2 11G	G10_049	FROM->TO	ST JOHN - ST_JOHN 115KV CKT 1	86	0.21264	116.6355	GEN560342 1-G10-49 0.6900
FDNS	3		0 11G	G10_049	FROM->TO	ST JOHN - ST_JOHN 115KV CKT 1	86	0.21325	116.1706	GEN539670 4-JUDSON LARGE GENERATOR
FDNS	3		0 11G	G10_049	FROM->TO	ST JOHN - ST_JOHN 115KV CKT 1	86	0.21383	115.9319	GRAY CO 345.00 - SPEARVILLE 345KV CKT 1
FDNS	3		0 11G	G10_049	FROM->TO	ST JOHN - ST_JOHN 115KV CKT 1	86	0.21325	115.6493	GEN531447 1-HOLCOMB GENERATOR
FDNS	3		2 11G	G10_049	FROM->TO	ST JOHN - ST_JOHN 115KV CKT 1	86	0.21225	115.1125	WRTOD400
FDNS	2		2 11G	G10_049	FROM->TO	ST JOHN - ST_JOHN 115KV CKT 1	86	0.2191	114.6748	DBL-MEDLO-WI
FDNS	3		2 11G	G10_049	FROM->TO	ST JOHN - ST_JOHN 115KV CKT 1	86	0.21265	114.6316	GEN531447 1-HOLCOMB GENERATOR

SOLUTION	GROUP	SCENARIO	SEASON	SOURCE	DIRECTION	MONITORED ELEMENT COMMON NAME	RATEB	TDF	TC%LOADING	CONTINGENCY NAME
FDNS	3		0 11G	G10_049	FROM->TO	ST JOHN - ST_JOHN 115KV CKT 1	86	0.26247	113.9748	MULLERGREN (MULGRENG) 230/115/13.8KV TRANSFORMER CKT 1
FDNS	3		2 11G	G10_049	FROM->TO	ST JOHN - ST_JOHN 115KV CKT 1	86	0.26208	113.8134	MULLERGREN (MULGRENG) 230/115/13.8KV TRANSFORMER CKT 1
FDNS	2		0 11G	G10_049	FROM->TO	ST JOHN - ST_JOHN 115KV CKT 1	86	0.2198	113.4607	DBL-MEDLO-WI
FDNS	00G10_049		2 16WP	G10_049	FROM->TO	ST JOHN - ST_JOHN 115KV CKT 1	86	0.38861	113.3073	PRATT - SAWYER 3 115.00 115KV CKT 1
FDNS	3		2 11G	G10_049	FROM->TO	ST JOHN - ST_JOHN 115KV CKT 1	86	0.21265	113.2891	GEN560502 1-G01_039A 0.6000
FDNS	00G10_049		2 16WP	G10_049	FROM->TO	ST JOHN - ST_JOHN 115KV CKT 1	86	0.38861	113.2674	MEDICINE LODGE - SAWYER 3 115.00 115KV CKT 1
FDNS	3		0 11G	G10_049	FROM->TO	ST JOHN - ST_JOHN 115KV CKT 1	86	0.21325	113.181	GEN539677 3-A. M. MULLERGREN GENERATOR
FDNS	00G10_049		2 12WP	G10_049	FROM->TO	ST JOHN - ST_JOHN 115KV CKT 1	86	0.38865	113.0181	PRATT - SAWYER 3 115.00 115KV CKT 1
FDNS	00G10_049		2 12WP	G10_049	FROM->TO	ST JOHN - ST_JOHN 115KV CKT 1	86	0.38865	112.9784	MEDICINE LODGE - SAWYER 3 115.00 115KV CKT 1
FDNS	00G10_049		2 12SP	G10_049	FROM->TO	ST JOHN - ST_JOHN 115KV CKT 1	86	0.389	112.2804	PRATT - SAWYER 3 115.00 115KV CKT 1
FDNS	3		2 11G	G10_049	FROM->TO	ST JOHN - ST_JOHN 115KV CKT 1	86	0.21265	111.6431	GEN539677 3-A. M. MULLERGREN GENERATOR
FDNS	3		0 11G	G10_049	FROM->TO	ST JOHN - ST_JOHN 115KV CKT 1	86	0.21325	110.4809	GEN560342 1-G10-49 0.6900
FDNS	3		2 11G	G10_049	FROM->TO	ST JOHN - ST_JOHN 115KV CKT 1	86	0.21536	110.4168	MULLERGREN - SPEARVILLE 230KV CKT 1
FDNS	00G10_049		2 12SP	G10_049	FROM->TO	ST JOHN - ST_JOHN 115KV CKT 1	86	0.39343	109.3109	SEWARD - ST JOHN 115KV CKT 1
FDNS	00G10_049		0 16WP	G10_049	FROM->TO	ST JOHN - ST_JOHN 115KV CKT 1	86	0.38938	108.931	PRATT - SAWYER 3 115.00 115KV CKT 1
FDNS	3		2 11G	G10_049	FROM->TO	ST JOHN - ST_JOHN 115KV CKT 1	86	0.21265	108.9189	GEN560342 1-G10-49 0.6900
FDNS	00G10_049		0 16WP	G10_049	FROM->TO	ST JOHN - ST_JOHN 115KV CKT 1	86	0.38938	108.8923	MEDICINE LODGE - SAWYER 3 115.00 115KV CKT 1
FDNS	00G10_049		2 16WP	G10_049	FROM->TO	ST JOHN - ST_JOHN 115KV CKT 1	86	0.39319	108.7209	SEWARD - ST JOHN 115KV CKT 1
FDNS	00G10_049		2 16SP	G10_049	FROM->TO	ST JOHN - ST_JOHN 115KV CKT 1	86	0.38899	108.3168	PRATT - SAWYER 3 115.00 115KV CKT 1
FDNS	00G10_049		0 12WP	G10_049	FROM->TO	ST JOHN - ST_JOHN 115KV CKT 1	86	0.38941	108.2942	PRATT - SAWYER 3 115.00 115KV CKT 1
FDNS	00G10_049		2 16SP	G10_049	FROM->TO	ST JOHN - ST_JOHN 115KV CKT 1	86	0.38899	108.2738	MEDICINE LODGE - SAWYER 3 115.00 115KV CKT 1
FDNS	00G10_049		0 12WP	G10_049	FROM->TO	ST JOHN - ST_JOHN 115KV CKT 1	86	0.38941	108.2556	MEDICINE LODGE - SAWYER 3 115.00 115KV CKT 1
FDNS	3		0 11G	G10_049	FROM->TO	ST JOHN - ST_JOHN 115KV CKT 1	86	0.23226	108.2359	G01_039AT 115.00 - GREENSBURG 115KV CKT 1
FDNS	00G10_049		2 12WP	G10_049	FROM->TO	ST JOHN - ST_JOHN 115KV CKT 1	86	0.39324	108.2077	SEWARD - ST JOHN 115KV CKT 1
FDNS	00G10_049		0 12SP	G10_049	FROM->TO	ST JOHN - ST_JOHN 115KV CKT 1	86	0.38975	108.1464	PRATT - SAWYER 3 115.00 115KV CKT 1
FDNS	00G10_049		0 12SP	G10_049	FROM->TO	ST JOHN - ST_JOHN 115KV CKT 1	86	0.38975	108.1059	MEDICINE LODGE - SAWYER 3 115.00 115KV CKT 1
FDNS	3		2 11G	G10_049	FROM->TO	ST JOHN - ST_JOHN 115KV CKT 1	86	0.23189	107.7819	G01_039AT 115.00 - GREENSBURG 115KV CKT 1
FDNS	00G10_049		2 16SP	G10_049	FROM->TO	ST JOHN - ST_JOHN 115KV CKT 1	86	0.3934	107.1331	SEWARD - ST JOHN 115KV CKT 1
FDNS	00G10_049		0 12SP	G10_049	FROM->TO	ST JOHN - ST_JOHN 115KV CKT 1	86	0.39355	105.231	SEWARD - ST JOHN 115KV CKT 1
FDNS	1		2 11G	G10_049	FROM->TO	ST JOHN - ST_JOHN 115KV CKT 1	86	0.21931	104.761	DBL-MEDLO-WI
FDNS	1		3 11G	G10_049	FROM->TO	ST JOHN - ST_JOHN 115KV CKT 1	86	0.21931	104.7234	DBL-MEDLO-WI
FDNS	00G10_049		0 16WP	G10_049	FROM->TO	ST JOHN - ST_JOHN 115KV CKT 1	86	0.3933	104.5103	SEWARD - ST JOHN 115KV CKT 1
FDNS	00G10_049		0 16SP	G10_049	FROM->TO	ST JOHN - ST_JOHN 115KV CKT 1	86	0.38975	104.043	PRATT - SAWYER 3 115.00 115KV CKT 1
FDNS	00G10_049		0 12WP	G10_049	FROM->TO	ST JOHN - ST_JOHN 115KV CKT 1	86	0.39335	104.0338	SEWARD - ST JOHN 115KV CKT 1
FDNS	00G10_049		0 16SP	G10_049	FROM->TO	ST JOHN - ST_JOHN 115KV CKT 1	86	0.38975	104.0014	MEDICINE LODGE - SAWYER 3 115.00 115KV CKT 1
FDNS	1		0 11G	G10_049	FROM->TO	ST JOHN - ST_JOHN 115KV CKT 1	86	0.22	103.8736	DBL-MEDLO-WI
FDNS	00G10_049		0 16SP	G10_049	FROM->TO	ST JOHN - ST_JOHN 115KV CKT 1	86	0.39353	103.0246	SEWARD - ST JOHN 115KV CKT 1
FDNS	00G10_049		2 16WP	G10_049	FROM->TO	ST JOHN - ST_JOHN 115KV CKT 1	86	0.21838	102.673	DBL-MEDLO-WI
FDNS	00G10_049		2 12WP	G10_049	FROM->TO	ST JOHN - ST_JOHN 115KV CKT 1	86	0.21844	101.3679	DBL-MEDLO-WI
FDNS	00G10_049		0 16WP	G10_049	FROM->TO	ST JOHN - ST_JOHN 115KV CKT 1	86	0.21906	100.3572	DBL-MEDLO-WI
FNSL	03G10_049		0 11G	G10_049	FROM->TO	ST JOHN - ST_JOHN 115KV CKT 1	86	0.22118	161.9388	CIRCLE - MULLERGREN 230KV CKT 1
FNSL	03G10_049		0 11G	G10_049	FROM->TO	ST JOHN - ST_JOHN 115KV CKT 1	86	0.39018	147.7922	PRATT - SAWYER 3 115.00 115KV CKT 1
FNSL	03G10_049		0 11G	G10_049	FROM->TO	ST JOHN - ST_JOHN 115KV CKT 1	86	0.39018	147.7628	MEDICINE LODGE - SAWYER 3 115.00 115KV CKT 1
FNSL	03G10_049		2 11G	G10_049	FROM->TO	ST JOHN - ST_JOHN 115KV CKT 1	86	0.21371	147.1134	DBL-SPRVL-CO
FNSL	03G10_049		0 11G	G10_049	FROM->TO	ST JOHN - ST_JOHN 115KV CKT 1	86	0.21413	141.4573	SMOKYHL6 230.00 - SUMMIT 230KV CKT 1
FNSL	03G10_049		0 11G	G10_049	FROM->TO	ST JOHN - ST_JOHN 115KV CKT 1	86	0.21444	141.4198	Hitchland Interchange - STEVENSCO 345.00 345KV CKT 1
FNSL	03G10_049		0 11G	G10_049	FROM->TO	ST JOHN - ST_JOHN 115KV CKT 1	86	0.21444	139.1111	FINNEY SWITCHING STATION - STEVENSCO 345.00 345KV CKT 1
FNSL	03G10_049		0 11G	G10_049	FROM->TO	ST JOHN - ST_JOHN 115KV CKT 1	86	0.21413	138.3665	KNOLL 230 - SMOKYHL6 230.00 230KV CKT 1
FNSL	03G10_049		0 11G	G10_049	FROM->TO	ST JOHN - ST_JOHN 115KV CKT 1	86	0.21383	137.6666	NORTHWEST - TATONGA7 345.00 345KV CKT 1
FNSL	03G10_049		0 11G	G10_049	FROM->TO	ST JOHN - ST_JOHN 115KV CKT 1	86	0.21324	137.632	GEN532751 1-WOLF CREEK GENERATING STATION UNIT 1
FNSL	03G10_049		0 11G	G10_049	FROM->TO	ST JOHN - ST_JOHN 115KV CKT 1	86	0.21364	137.5105	COMANCHS 345.00 - MED-LDG5 345.00 345KV CKT 1
FNSL	03G10_049		0 11G	G10_049	FROM->TO	ST JOHN - ST_JOHN 115KV CKT 1	86	0.21364	137.5105	COMANCHS 345.00 - MED-LDG5 345.00 345KV CKT 2
FNSL	03G10_049		0 11G	G10_049	FROM->TO	ST JOHN - ST_JOHN 115KV CKT 1	86	0.21493	136.6412	AXTELL - POSTROCK7 345.00 345KV CKT 1
FNSL	03G10_049		0 11G	G10_049	FROM->TO	ST JOHN - ST_JOHN 115KV CKT 1	86	0.21403	135.4381	SPP-MKEC-08
FNSL	03G10_049		0 11G	G10_049	FROM->TO	ST JOHN - ST_JOHN 115KV CKT 1	86	0.21377	135.1948	MINGO - RED WILLOW 345KV CKT 1
FNSL	03G10_049		2 11G	G10_049	FROM->TO	ST JOHN - ST_JOHN 115KV CKT 1	86	0.21274	134.2316	DBL-G0847-WO

SOLUTION	GROUP	SCENARIO	SEASON	SOURCE	DIRECTION	MONITORED ELEMENT COMMON NAME	RATEB	TDF	TC%LOADING	CONTINGENCY NAME
FNSL	3		0 11G	G10_049	FROM->TO	ST JOHN - ST_JOHN 115KV CKT 1	86	0.21414	131.0485	SMOKYHL6 230.00 - SUMMIT 230KV CKT 1
FNSL	3		0 11G	G10_049	FROM->TO	ST JOHN - ST_JOHN 115KV CKT 1	86	0.21445	130.2185	Hitchland Interchange - STEVENSCO 345.00 345KV CKT 1
FNSL	3		0 11G	G10_049	FROM->TO	ST JOHN - ST_JOHN 115KV CKT 1	86	0.39018	129.1419	PRATT - SAWYER 3 115.00 115KV CKT 1
FNSL	3		0 11G	G10_049	FROM->TO	ST JOHN - ST_JOHN 115KV CKT 1	86	0.39018	129.1151	MEDICINE LODGE - SAWYER 3 115.00 115KV CKT 1
FNSL	3		0 11G	G10_049	FROM->TO	ST JOHN - ST_JOHN 115KV CKT 1	86	0.21445	128.4875	FINNEY SWITCHING STATION - STEVENSCO 345.00 345KV CKT 1
FNSL	3		0 11G	G10_049	FROM->TO	ST JOHN - ST_JOHN 115KV CKT 1	86	0.21325	127.6447	GEN532751 1-WOLF CREEK GENERATING STATION UNIT 1
FNSL	3		0 11G	G10_049	FROM->TO	ST JOHN - ST_JOHN 115KV CKT 1	86	0.21365	126.9858	COMANCH5 345.00 - MED-LDG5 345.00 345KV CKT 1
FNSL	3		0 11G	G10_049	FROM->TO	ST JOHN - ST_JOHN 115KV CKT 1	86	0.21365	126.9858	COMANCH5 345.00 - MED-LDG5 345.00 345KV CKT 2
FNSL	3		0 11G	G10_049	FROM->TO	ST JOHN - ST_JOHN 115KV CKT 1	86	0.21404	125.0784	SPP-MKEC-08
FNSL	03G10_049		0 11G	G10_049	FROM->TO	ST JOHN - ST_JOHN 115KV CKT 1	86	0.21324	124.9406	GEN560502 1-G01_039A 0.6000
FNSL	3		0 11G	G10_049	FROM->TO	ST JOHN - ST_JOHN 115KV CKT 1	86	0.21377	124.7399	MINGO - RED WILLOW 345KV CKT 1
FNSL	03G10_049		0 11G	G10_049	FROM->TO	ST JOHN - ST_JOHN 115KV CKT 1	86	0.21581	121.7479	MULLERGREN - SPEARVILLE 230KV CKT 1
FNSL	03G10_049		0 11G	G10_049	FROM->TO	ST JOHN - ST_JOHN 115KV CKT 1	86	0.23226	119.0437	G01_039AT 115.00 - GREENSBURG 115KV CKT 1
FNSL	03G10_049		2 11G	G10_049	FROM->TO	ST JOHN - ST_JOHN 115KV CKT 1	86	0.23189	118.4939	G01_039AT 115.00 - GREENSBURG 115KV CKT 1
FNSL	3		0 11G	G10_049	FROM->TO	ST JOHN - ST_JOHN 115KV CKT 1	86	0.21325	114.8171	GEN560502 1-G01_039A 0.6000
FNSL	3		0 11G	G10_049	FROM->TO	ST JOHN - ST_JOHN 115KV CKT 1	86	0.21581	111.4954	MULLERGREN - SPEARVILLE 230KV CKT 1
FNSL-Blown up	03ALL		0 11G	G10_051		Non Converged Contingency	1052	0.07511	67.17995	Hitchland Interchange - STEVENSCO 345.00 345KV CKT 1
FNSL-Blown up	03ALL		0 11G	G10_051		Non Converged Contingency	0	0.06637	9999	DBL-SPRVL-CO
FNSL-Blown up	03ALL		0 11G	G10_051		Non Converged Contingency	0	0.06637	9999	DBL-COM-MEDL
FNSL-Blown up	03ALL		0 11G	G10_051		Non Converged Contingency	1052	0.07511	59.28579	FINNEY SWITCHING STATION - STEVENSCO 345.00 345KV CKT 1
FNSL-Blown up	3		0 11G	G10_051		Non Converged Contingency	0	0.06686	9999	DBL-COM-MEDL
FNSL-Blown up	02ALL		0 11G	G10_052		Non Converged Contingency	0	0.12084	9999	DBL-G0847-WO
FNSL-Blown up	03ALL		0 11G	G10_052		Non Converged Contingency	1052	0.3308	67.17995	Hitchland Interchange - STEVENSCO 345.00 345KV CKT 1
FNSL-Blown up	03ALL		0 11G	G10_052		Non Converged Contingency	0	0.27657	9999	DBL-SPRVL-CO
FNSL-Blown up	03ALL		0 11G	G10_052		Non Converged Contingency	0	0.27657	9999	DBL-COM-MEDL
FNSL-Blown up	03ALL		0 11G	G10_052		Non Converged Contingency	0	0.22433	9999	DBL-MEDLO-WI
FNSL-Blown up	03ALL		0 11G	G10_052		Non Converged Contingency	1052	0.3308	59.28579	FINNEY SWITCHING STATION - STEVENSCO 345.00 345KV CKT 1
FNSL-Blown up	00G10_052		2 16SP	G10_052		Non Converged Contingency	0	0.04436	9999	TRF-STEGALL
FNSL-Blown up	00G10_052		2 16WP	G10_052		Non Converged Contingency	0	0.04395	9999	TRF-STEGALL
FNSL-Blown up	00G10_052		0 16SP	G10_052		Non Converged Contingency	0	0.048	9999	TRF-STEGALL
FNSL-Blown up	00G10_052		0 16SP	G10_052		Non Converged Contingency	0	0.032	9999	NEB01WAPAB3
FNSL-Blown up	00G10_052		0 16WP	G10_052		Non Converged Contingency	0	0.04758	9999	TRF-STEGALL
FNSL-Blown up	00G10_052		0 16WP	G10_052		Non Converged Contingency	0	0.03172	9999	NEB01WAPAB3
FNSL-Blown up	0		0 16SP	G10_052		Non Converged Contingency	0	0.048	9999	TRF-STEGALL
FNSL-Blown up	0		0 16SP	G10_052		Non Converged Contingency	0	0.032	9999	NEB01WAPAB3
FNSL-Blown up	0		0 16WP	G10_052		Non Converged Contingency	0	0.04761	9999	TRF-STEGALL
FNSL-Blown up	0		0 16WP	G10_052		Non Converged Contingency	0	0.03174	9999	NEB01WAPAB3
FNSL-Blown up	03G10_052		0 11G	G10_052		Non Converged Contingency	0	0.27702	9999	DBL-COM-MEDL
FNSL-Blown up	03G10_052		0 11G	G10_052		Non Converged Contingency	0	0.22518	9999	DBL-MEDLO-WI
FNSL-Blown up	3		0 11G	G10_052		Non Converged Contingency	0	0.27706	9999	DBL-COM-MEDL
FNSL-Blown up	0		2 16SP	G10_052		Non Converged Contingency	0	0.04439	9999	TRF-STEGALL
FNSL-Blown up	0		2 16WP	G10_052		Non Converged Contingency	0	0.04401	9999	TRF-STEGALL
FNSL-Blown up	0		3 16SP	G10_052		Non Converged Contingency	0	0.04438	9999	TRF-STEGALL
FNSL-Blown up	0		3 16WP	G10_052		Non Converged Contingency	0	0.044	9999	TRF-STEGALL
FNSL-Blown up	0		2 16SP	G10_052		Non Converged Contingency	0	0.04439	9999	TRF-STEGALL
FNSL-Blown up	0		2 16WP	G10_052		Non Converged Contingency	0	0.04401	9999	TRF-STEGALL
FNSL-Blown up	03ALL		0 11G	G10_053		Non Converged Contingency	1052	0.11427	67.17995	Hitchland Interchange - STEVENSCO 345.00 345KV CKT 1
FNSL-Blown up	03ALL		0 11G	G10_053		Non Converged Contingency	0	0.56707	9999	DBL-COM-MEDL
FNSL-Blown up	03ALL		0 11G	G10_053		Non Converged Contingency	0	0.33364	9999	DBL-MEDLO-WI
FNSL-Blown up	03ALL		0 11G	G10_053		Non Converged Contingency	1052	0.11427	59.28579	FINNEY SWITCHING STATION - STEVENSCO 345.00 345KV CKT 1
FNSL-Blown up	03G10_053		0 11G	G10_053		Non Converged Contingency	0	0.56751	9999	DBL-COM-MEDL
FNSL-Blown up	03G10_053		0 11G	G10_053		Non Converged Contingency	0	0.33462	9999	DBL-MEDLO-WI
FNSL-Blown up	3		0 11G	G10_053		Non Converged Contingency	0	0.56756	9999	DBL-COM-MEDL

H: Power flow Analysis (Constraints with greater than 3% TDF)

Available Upon Request.