

Definitive Interconnection System Impact Study for Generation Interconnection Requests

Southwest Power Pool
Engineering Department
Tariff Studies – Generation Interconnection

(DISIS-2010-001-1 Study)
January 2011



SPP RESTRICTED

Definitive Interconnection System Impact Study for Generation Interconnection Requests

Southwest Power Pool
Engineering Department
Tariff Studies – Generation Interconnection

(DISIS-2010-001 Study)
July 2010

Date	Rev.	Comment
July 30, 2010	0	Issued Report
January 2011	1	Account for Withdrawn Projects

Executive Summary

Pursuant to the Southwest Power Pool (SPP) Open Access Transmission Tariff (OATT), SPP has conducted this Definitive Interconnection System Impact Study (DISIS) for certain generation interconnection requests in the SPP Generation Interconnection Queue. These interconnection requests have been clustered together for the following Impact Study. This Impact Re-Study is being performed to account for the withdrawal of higher and equally queued customers. The customers will be referred to in this study as the DISIS-2010-001 Interconnection Customers. This Impact Study analyzes the interconnecting of multiple generation interconnection requests associated with new generation totaling 4,504 MW of new generation which would be located within the transmission systems of American Electric Power West (AEPW), Midwest Energy Inc. (MIDW), Missouri Public Service (MIPU), Mid-Kansas Electric Power LLC (MKEC), Nebraska Public Power District (NPPD), Oklahoma Gas and Electric (OKGE), Southwestern Public Service (SPS), Sunflower Electric Power Corporation (SUNC), Westar Energy (WERE). The various generation interconnection requests have differing proposed in-service dates¹. The generation interconnection requests included in this DISIS are listed in Appendix A by their queue number, amount, area, requested interconnection point, proposed interconnection point, and the requested in-service date.

Power flow analysis has indicated that for the powerflow cases studied, 4,504 MW of nameplate generation may be interconnected with transmission system reinforcements within the SPP transmission system. Dynamic Stability and power factor analysis has determined the need for reactive compensation in accordance with Order No. 661-A for wind farm interconnection requests and those requirements are listed for each interconnection request within the contents of this report.

Dynamic Stability Analysis has determined that the transmission system will remain stable with the assigned Network Upgrades and necessary reactive compensation requirements.

The total estimated minimum cost for interconnecting the DISIS-2010-001 interconnection customers is \$350,000,000. These costs are shown in Appendices E and F. Interconnection Service to DISIS-2010-001 interconnection customers is also contingent upon higher queued customers paying for certain required network upgrades. The in service date for the DISIS customers will be deferred until the construction of these network upgrades can be completed.

These costs do not include the Interconnection Customer Interconnection Facilities as defined by the SPP Open Access Transmission Tariff (OATT). This cost does not include additional network constraints in the SPP transmission system that were identified as shown in Appendix H.

Network Constraints listed in Appendix H are in the local area of the new generation when this generation is injected throughout the SPP footprint for the Energy Resource (ER) Interconnection Request. Additional Network constraints will have to be verified with a Transmission Service Request (TSR) and associated studies. With a defined source and sink in a TSR, this list of Network Constraints will be refined and expanded to account for all Network Upgrade requirements.

¹ The generation interconnection requests in-service dates will need to be deferred based on the required lead time for the Network Upgrades necessary. The Interconnection Customer's that proceed to the Facility Study will be provided a new in-service date based on the completion of the Facility Study.

The required interconnection costs listed in Appendices E and F do not include all costs associated with the deliverability of the energy to final customers. These costs are determined by separate studies if the Customer submits a Transmission Service Request through SPP's Open Access Same Time Information System (OASIS) as required by Attachment Z1 of the SPP OATT.

Based on the SPP Tariff Attachment O, transmission facilities that are part of the SPP Transmission Expansion Plan (STEP) including Sponsored Economic Upgrades or the Balanced Portfolio that are approved by the SPP Board of Directors will receive notifications to construct. These projects will then be considered construction pending projects and would not be assignable to the Impact Cluster Study Generation Interconnection Requests.

Table of Contents

Introduction.....	6
Model Development	6
Identification of Network Constraints	9
Determination of Cost Allocated Network Upgrades	10
Interconnection Facilities	11
Powerflow.....	11
Stability Analysis.....	12
Conclusion	16
Appendix	17
A: Generation Interconnection Requests Considered for Impact Study.....	A-1
B: Prior Queued Interconnection Requests	B-1
C: Study Groupings.....	C-1
D: Proposed Point of Interconnection One line Diagrams	D-1
E: Cost Allocation per Interconnection Request (Including Prior Queued Upgrades).....	E-1
F: Cost Allocation per Current Study Network Upgrade	F-1
G: Powerflow Analysis (Constraints for Mitigation).....	G-1
H: Stability Analysis	H-1

Introduction

Pursuant to the Southwest Power Pool (SPP) Open Access Transmission Tariff (OATT), SPP has conducted this Definitive Interconnection System Impact Study (DISIS) for certain generation interconnection requests in the SPP Generation Interconnection Queue. These interconnection requests have been clustered together for the following Impact Study. The customers will be referred to in this study as the DISIS-2010-001 Interconnection Customers. This Impact Study analyzes the interconnecting of multiple generation interconnection requests associated with new generation totaling 4,504 MW of new generation which would be located within the transmission systems of American Electric Power West (AEPW), Midwest Energy Inc. (MIDW), Missouri Public Service (MIPU), Mid-Kansas Electric Power LLC (MKEC), Nebraska Public Power District (NPPD), Oklahoma Gas and Electric (OKGE), Southwestern Public Service (SPS), Sunflower Electric Power Corporation (SUNC), Westar Energy (WERE). The various generation interconnection requests have differing proposed in-service dates². The generation interconnection requests included in this Impact Cluster Study are listed in Appendix A by their queue number, amount, area, requested interconnection point, proposed interconnection point, and the requested in-service date.

The primary objective of this Definitive Interconnection System Impact Study is to identify the system constraints associated with connecting the generation to the area transmission system. The Impact and other subsequent Interconnection Studies are designed to identify attachment facilities, Network Upgrades and other Direct Assignment Facilities needed to accept power into the grid at each specific interconnection receipt point.

Model Development

Interconnection Requests Included in the DISIS-2010-001 Study

SPP has included all interconnection requests that submitted a Definitive Interconnection System Impact Study request no later than March 31, 2010 and were subsequently accepted by Southwest Power Pool under the terms of the Generation Interconnection Procedures (GIP) that became effective March 31, 2010.

Affected System Interconnection Requests - Also included in this Definitive Impact Study are four Affected System Studies, one on the Lea County Electric Cooperative system in Lea County, New Mexico (given the designation ASGI-2010-010) and three wind farm requests on the Tri County Electric Cooperative system in Texas County, Oklahoma (given the collective designation ASGI-2010-011).

The interconnection requests that are included in this study are listed in Appendix A.

² The generation interconnection requests in-service dates will need to be deferred based on the required lead time for the Network Upgrades necessary. The Interconnection Customer's that proceed to the Facility Study will be provided a new in-service date based on the completion of the Facility Study.

Previous Queued Projects

The previous queued projects included in this study are listed in Appendix B. In addition to the Base Case Upgrades, the previous queued projects and associated upgrades were assumed to be in-service and added to the Base Case models. These projects were dispatched as Energy Resources with equal distribution across the SPP footprint.

Development of Base Cases

Powerflow - The 2010 series Transmission Service Request (TSR) Models 2011 spring and 2016 summer and winter peak scenario 0 peak cases were used for this study. After the 2011 spring and the 2016 summer and winter peak cases were developed, each of the control areas' resources were then re-dispatched using current dispatch orders.

Stability – The 2010 series SPP Model Development Working Group (MDWG) Models 2011 winter and 2011 summer were used for this study.

Base Case Upgrades

The following facilities are part of the SPP Transmission Expansion Plan or the Balanced Portfolio or recently approved Priority Projects. These facilities have been approved or are in construction stages and were assumed to be in-service at the time of dispatch and added to the base case models. The DISIS-2010-001 Customers have not been assigned cost for the below listed projects. The DISIS-2010-001 Customers Generation Facilities in service dates may need to be delayed until the completion of the following upgrades. If for some reason, construction on these projects is discontinued, additional restudies will be needed to determine the interconnection needs of the DISIS customers.

- Woodward – Northwest 345kV line and associated projects to be built by OKGE placed in service in 2010.
- Hitchland 345/230/115kV upgrades to be built by SPS for 2010/2011 in-service³.
 - Hitchland – Moore County 230kV line
 - Hitchland – Perryton 230kV line
 - Hitchland – Texas County 115kV line
 - Hitchland – Hansford County 115kV line
 - Hitchland – Sherman County Tap 115kV line
- Valliant – Hugo – Sunnyside 345kV – assigned to Aggregate Study AG3-2006 Customers for 2012 in-service.
- Wichita – Reno County – Summit 345kV to be built by WERE for 2010 in-service⁴.
- Rose Hill – Sooner 345kV to be built by WERE/OKGE for 2013 in-service.
- Knob Hill – Steele City 115kV to be built by NPPD/WERE for 2010 in-service.
- Balanced Portfolio Projects⁵:
 - Anadarko 345/138/13.2kV Autotransformer
 - Woodward – TUCO 345kV line
 - Iatan – Nashua 345kV line
 - Muskogee – Seminole 345kV line

³ Approved 230kV upgrades are based on SPP 2007 STEP. Upgrades may need to be re-evaluated in the system impact study.

⁴ Approved based on an order of the Kansas Corporation Commission issued in Docket no. 07-WSEE-715-MIS

⁵ Notice to Construct (NTC) issued June, 2009

- Knoll – Axtell 345kV line
- Spearville – Knoll 345kV line
- Tap Stillwell – Swissvale 345kV line at West Gardner
- Priority Projects⁶:
 - Hitchland - Woodward double circuit 345kV
 - Woodward – Medicine Lodge double circuit 345kV
 - Spearville – Comanche double circuit 345kV
 - Comanche – Medicine Lodge double circuit 345kV
 - Medicine Lodge – Wichita double circuit 345kV
 - Medicine Lodge 345/138kV autotransformer

Contingent Upgrades

The following facilities do not yet have approval. These facilities have been assigned to higher queued interconnection customers. These facilities have been included in the models for the DISIS-2010-001 study and are assumed to be in service. The DISIS-2010-001 Customers at this time do not have responsibility for these facilities but may later be assigned the cost of these facilities if higher queued customers terminate their GIA or withdraw from the interconnection queue. The DISIS-2010-001 Customer Generation Facilities in service dates may need to be delayed until the completion of the following upgrades.

- Finney – Holcomb 345kV Ckt #2 line assigned to GEN-2006-044 interconnection customer. This customer is currently in suspension⁷.
- Central Plains – Setab 115kV transmission line assigned to GEN-2007-013 interconnection customer. This customer is currently is suspension.
- Spearville 345/230kV autotransformer #2 assigned to 1st Cluster Interconnection Customers (100% to GEN-2006-006)
- Grassland 230/115kV autotransformer #2 assigned to 1st Cluster Interconnection Customers (100% to GEN-2008-016)
- Spearville 230/115kV autotransformer #2 assigned to DIS-2009-001-1 Interconnection Customers (100% to GEN-2008-079)
- Petersburg – Madison 115kV assigned to DIS-2009-001-1 Interconnection Customers
- Judson Large – North Judson Large – Spearville Ckt #2 assigned to DIS-2009-001-1 Interconnection Customers (100% to GEN-2008-079)
- GEN-2008-038 Tap – Barnsdall 138kV assigned to DIS-2009-001-1 Interconnection Customers (100% to GEN-2008-038)
- Belden – Bloomfield 115kV assigned to DIS-2009-001-1 Interconnection Customers

Potential Upgrades Not in the Base Case

⁶ Notice to Construct (NTC) issued June, 2010. NTC for double circuit lines indicated that NTC may be revised at a later time to be built at a higher voltage.

⁷ Based on Facility Study Posting November 2008

Any potential upgrades that do not have a Notification to Construct (NTC) have not been included in the base case. These upgrades include any identified in the SPP Extra-High Voltage (EHV) overlay plan or any other SPP planning study other than the upgrades listed above in the previous sections.

Regional Groupings

The interconnection requests listed in Appendix A were grouped together in fourteen different regional groups based on geographical and electrical impacts. These groupings are shown in Appendix C.

To determine interconnection impacts, fourteen different dispatch variations of the spring base case models were developed to accommodate the regional groupings.

Powerflow - For each group, the various wind generating plants were modeled at 80% nameplate of maximum generation. The wind generating plants in the other areas were modeled at 20% nameplate of maximum generation. This process created fifteen different scenarios with each group being studied at 80% nameplate rating. These projects were dispatched as Energy Resources with equal distribution across the SPP footprint. This method allowed for the identification of network constraints that were common to the regional groupings that could then in turn have the mitigating upgrade cost allocated throughout the entire cluster. Each interconnection request was also modeled separately at 100% nameplate for certain analyses.

Peaking units were not dispatched in the 2011 spring model. To study peaking units' impacts, the 2016 summer and winter peak model was chosen and peaking units were modeled at 100% of the nameplate rating and wind generating facilities were modeled at 10% of the nameplate rating.

Stability - For each group, all interconnection requests (wind and non-wind) were modeled at 100% nameplate of maximum generation in both winter and summer seasonal models. The wind interconnection requests in the other areas were modeled at 20% nameplate of maximum generation while fossil units were modeled at 100% in the other areas. This process created twelve different scenarios with each group being studied at 100% nameplate rating. These projects were dispatched as Energy Resources with equal distribution across the SPP footprint.

Identification of Network Constraints

The initial set of network constraints were found by using PTI MUST First Contingency Incremental Transfer Capability (FCITC) analysis on the entire cluster grouping dispatched at the various levels mentioned above. These constraints were then screened to determine if any of the generation interconnection requests had at least a 20% Distribution Factor (DF) upon the constraint. Constraints that measured at least a 20% DF from at least one interconnection request were considered for mitigation.

Determination of Cost Allocated Network Upgrades

Cost Allocated Network Upgrades of wind generation interconnection requests were determined using the 2011 spring model. Cost Allocated Network Upgrades of peaking units was determined using the 2016 summer peak model. Once a determination of the required Network Upgrades was made, a powerflow model of the 2010 spring case was developed with all cost allocated Network Upgrades in-service. A MUST FCITC analysis was performed to determine the Power Transfer Distribution Factors (PTDF), defined as a distribution factor with system impact conditions that each generation interconnection request had on each new upgrade. The impact each generation interconnection request had on each upgrade project was weighted by the size of each request. Finally the costs due by each request for a particular project were then determined by allocating the portion of each request's impact over the impact of all the required upgrades.

For example, assume that there are three Generation Interconnection requests, X, Y, and Z that are responsible for the costs of Upgrade Project '1'. Given that their respective PTDF for the project have been determined, the cost allocation for Generation Interconnection request 'X' for Upgrade Project 1 is found by the following set of steps and formulas:

- Determine an Impact Factor on a given project for all responsible GI requests:

$$\text{Request X Impact Factor on Upgrade Project 1} = \text{PTDF}(\%)(X) * \text{MW}(X) = X1$$

$$\text{Request Y Impact Factor on Upgrade Project 1} = \text{PTDF}(\%)(Y) * \text{MW}(Y) = Y1$$

$$\text{Request Z Impact Factor on Upgrade Project 1} = \text{PTDF}(\%)(Z) * \text{MW}(Z) = Z1$$

- Determine each request's Allocation of Cost for that particular project:

$$\text{Request X's Project 1 Cost Allocation (\$)} = \frac{\text{Network Upgrade Project 1 Cost}(\$) * X1}{X1 + Y1 + Z1}$$

- Repeat previous for each responsible GI request for each Project

The cost allocation of each needed Network Upgrade is determined by the size of each request and its impact on the given project. This allows for the most efficient and reasonable mechanism for sharing the costs of upgrades.

Credits for Amounts Advanced for Network Upgrades

Interconnection Customer shall be entitled to credits in accordance with Attachment Z1 of the SPP Tariff for any Network Upgrades including any tax gross-up or any other tax-related payments associated with the Network Upgrades, and not refunded to the Interconnection Customer.

Interconnection Facilities

The requirement to interconnect the 4,504 MW of generation into the existing and proposed transmission systems in the affected areas of the SPP transmission footprint consist of the necessary cost allocated shared facilities listed in Appendix F by upgrade. The interconnection requirements for the cluster total \$350,000,000. Interconnection Facilities, including prior allocated facilities, specific to each generation interconnection request are listed in Appendix E.

A list of constraints with greater than or equal to a 20% OTDF that were identified and used for mitigation are listed in Appendix G. Other Network Constraints in the AEPW, MIDW, MIPU, MKEC, NPPD, OKGE, SPS, SUNC, AND WERE transmission systems that were identified are shown in Appendix H. With a defined source and sink in a TSR, this list of Network Constraints will be refined and expanded to account for all Network Upgrade requirements.

A preliminary one-line drawing for each generation interconnection request are listed in Appendix D. Figure 1 depicts the major transmission line Network Upgrades needed to support the interconnection of the generation amounts requested in this study.

Powerflow

Powerflow Analysis Methodology

The Southwest Power Pool (SPP) Criteria states that:

“The transmission system of the SPP region shall be planned and constructed so that the contingencies as set forth in the Criteria will meet the applicable NERC Reliability Standards for transmission planning. All MDWG power flow models shall be tested to verify compliance with the System Performance Standards from NERC Table 1 – Category A.”

The ACCC function of PSS/E was used to simulate single contingencies in portions or all of the modeled control areas of American Electric Power West (AEPW), Empire District Electric (EMDE), Grand River Dam Authority (GRDA), Kansas City Power & Light (KCPL), Midwest Energy (MIDW), MIPU, MKEC, Nebraska Public Power District (NPPD), OG&E Electric Services (OKGE), Omaha Public Power District (OPPD), Southwest Public Service (SPS), Sunflower Electric (SUNC), Westar Energy (WERE), Western Farmers Electric Cooperative (WFEC) and other control areas were applied and the resulting scenarios analyzed. This satisfies the “more probable” contingency testing criteria mandated by NERC and the SPP criteria.

Powerflow Analysis

A powerflow analysis was conducted for each Interconnection Customer’s facility using modified versions of the 2010 spring peak and the 2014 summer and winter peak models. The output of the Interconnection Customer’s facility was offset in each model by a reduction in output of existing online SPP generation. This method allows the request to be studied as an Energy Resource (ER) Interconnection Request. The available seasonal models used were through the 2014 Summer Peak.

This analysis was conducted assuming that previous queued requests in the immediate area of these interconnect requests were in-service. The analysis of each Customer's project indicates that additional criteria violations will occur on the AEPW, MIDW, OKGE, SPS, SUNC, SWPA, MKEC, WERE, AND WFEC transmission systems under steady state and contingency conditions in the peak seasons.

Cluster Group 1 (Woodward Area)

The Woodward area contained approximately 292 MW of new interconnection requests in addition to the 3,053 MW of prior queued interconnection requests. Constraints were observed on the Northwest – Tatonga 345kV line and the Fargo Junction – Woodward 69kV line. To mitigate the Northwest – Tatonga 345kV constraint, a 345kV circuit from Wheeler – Border that was identified for Group 2 was found to mitigate the Group 1 constraint. To mitigate the Fargo Junction – Woodward 69kV constraint the line will need to be rebuilt.

Cluster Group 2 (Hitchland Area)

The Hitchland area contained 1,092 MW of interconnection request in addition to the 2,282 MW of previous queued generation interconnection requests. An outage of the Finney-Stevens County 345kV line or an outage of the double circuit 345kV line from Hitchland-Woodward was found to cause possible voltage collapse. To mitigate the constraint, a double 345kV circuit from Hitchland – Border (Wheeler). Additionally, the point of interconnection for GEN-2008-047 was located to the original requested position back to a point near the midpoint of the Hitchland-Woodward 345kV line as the line voltage of this line was not approved to be increased to 765kV.

Cluster Group 3 (Spearville Area)

The Spearville area contained 781 MW of interconnection requests and 2,333 MW of previous queued interconnection requests. There were constraints identified on the lower 230 and 115kV systems out of Spearville including the 115kV system near interconnection request GEN-2009-059. To mitigate these issues, a new 345/115kV autotransformer is necessary at Spearville as well as additional 115kV line capacity from Spearville toward the wind farms interconnecting on the Cudahy – Judson Large 115kV.

Cluster Group 4 (Mingo/NW Kansas Group)

The Mingo/NW Kansas group had 0 MW in addition to the 924 MW of previously queued generation in the area. No new constraints were found in this area.

Cluster Group 5 (Amarillo Area)

The Amarillo group had 51 MW of interconnection requests in addition to the 2,168 MW of previously queued interconnection requests in this area. The major constraint for the GEN-2008-088 request was on the Switch 2749 substation – Wildorado 69kV line. To mitigate the constraint, the line will need to be rebuilt. In addition, the GEN-2008-088 request was found to contribute to the possible voltage collapse for the outage of the Hitchland-Woodward 345kV double circuit and Finney-Stevens 345kV outage.

Cluster Group 6 (South Panhandle/New Mexico)

This group had 567 MW of interconnection requests in addition to the 1,390 MW of previously queued interconnection requests. The major constraints in the New Mexico area were on the Plant X Station – Tolk Station 230kV lines. To mitigate the constraints, the following actions were taken: Both Plant X Station – Tolk Station 230kV lines were rebuilt, and replacement terminal equipment on the Potter – Plant X 230kV line was modeled. The wind farm projects in Group 6 were also found to contribute to the possible voltage collapse on the Hitchland-Woodward 345kV double circuit.

Cluster Group 7 (Southwestern Oklahoma)

This group had 286 MW of interconnection requests in addition to the 1,838 MW of previous queued generation in the area. There were several constraints noticed in the Southwestern Oklahoma area, however, the major constraints were in the Clinton Junction and Weatherford areas due to GEN-2009-030 and constraints on the existing lines out of Washita substation due to all requests in the area. To mitigate the constraints in the area, the following upgrades were assigned to the study projects: a second Washita – Anadarko 138kV line was added, a 138kV line from Weatherford – Washita was added, replacement terminal equipment on the Blue Canyon – Washita 138kV line was modeled, and replacement terminal equipment on the GEN-2008-037 – Washita 138kV line was modeled.

Cluster Group 8 (South Central Kansas/North Oklahoma)

This group had 629 MW of interconnection requests in addition to the 3,217 MW of previous queued generation in the area. No new constraints were found in this area. Stability issues in the area of Wolf Creek were identified and are discussed in the stability section.

Cluster Group 9 (Northeast Nebraska)

This group had 201 MW of interconnection requests in addition to the 598 MW of previous queued generation in the area. The major constraints were overloads on the Columbus – Madison County – Ft. Randle 230kV line and the Madison – Norfolk 115kV line. To mitigate the constraints, a 115kV line from Madison County – Norfolk was added, and the Petersburg – Madison 115kV line was tapped and tied to the Madison County 230kV bus.

Cluster Group 10 (North Nebraska)

This group had 0 MW of interconnection requests in addition to the 284 MW of previous queued generation in the area.

Cluster Group 11 (North Kansas)

This group had 322 MW of interconnection requests in addition to the 976 MW of previous queued generation in the area. The major constraints for the North Kansas area are the South Hays – Hays Plant – Vine Street 115kV line, and the Smoky Hills – Summit 230kV line. To mitigate the constraints, the following actions were taken: the South Hays – Hays Plant – Vine Street 115kV line was rebuilt. Also, a second Knoll 345/230kV transformer was added to mitigate the Smoky Hills – Summit 230kV line. Constraints around the interconnection point of GEN-2009-040 were also found but relieved when the Knob Hill – Steele City 115kV STEP upgrade, slated for a 2010 in-service, was added to the base case.

Cluster Group 12 (Northwest Arkansas)

This group had 0 MW of interconnection requests in addition to the 0 MW of previous queued generation in the area.

Cluster Group 13 (Northwest Missouri)

This group had 0 MW of interconnection requests in addition to the 2,481 MW of previous queued generation in the area.

Cluster Group 14 (South Central Oklahoma)

This group had 206 MW of interconnection requests in addition to the 0 MW of previous queued generation in the area. No new constraints were found in this area.

Cluster Group 15 (Southwest Nebraska)

This group had 90 MW of interconnection requests in addition to the 0 MW of previous queued generation in the area. No new constraints were found in this area.

Stability Analysis

A selected stability analysis was conducted for each Interconnection Customer's facility using modified versions of the 2011 winter peak and the 2011 summer peak models. The stability analysis was conducted with all upgrades in service that were identified in the powerflow analysis. For each group, the interconnection requests were studied at 100% nameplate output while the other groups were dispatched at 20% output for wind requests and 100% output for fossil requests. The exception to this practice was that Groups 9 and 10 were combined at the request of Transmission Owner. This exception was analyzed due despite the large geographic area of the two groupings, there are limited transmission paths that the two groups share. The output of the Interconnection Customer's facility was offset in each model by a reduction in output of existing online SPP generation. The following synopsis is included for each group. A power factor analysis for each request was completed as well as selected 345kV outage stability simulations.

Cluster Group 1 (Woodward Area)

The analysis for Group 1 showed that a reactive power deficiency was apparent with addition of the interconnection request near Tatonga. The GEN-2008-044 and GEN-2010-011 interconnection requests will need to provide 95% lagging power factor at the point of interconnection (Tatonga). These requests combined will need to be able to provide over 71Mvar at the point of interconnection. This will require additional capacitor banks. With the power factor requirements and all network upgrades in service, all interconnection request in Group 1 will meet FERC Order #661A low voltage ride through (LVRT) requirements.

Power Factor Requirements

Request	Size (MW)	Generator Model	Point of Interconnection	Final PF Requirement at POI		Estimated Capacitor Requirement (Mvar)
				Lagging (supplying)	Leading (absorbing)	
GEN-2008-044 GEN-2010-011	197.8 29.7	Siemens SWT 2.3 MW	Tatonga 345kV	0.95	1.00	no
GEN-2010-008	64.4	Siemens SWT 2.3 MW	Fargo Jct 69kV	0.993	0.965	no

Cluster Group 2 (Hitchland Area)

The analysis for Group 2 showed that a reactive power deficiency was apparent with addition of the interconnection request near Hitchland. The GEN-2008-047 interconnection request will need to provide 95% lagging power factor at the point of interconnection. These requests combined will need to be able to provide over 400Mvar at the point of interconnection. This will require additional capacitor banks. With the power factor requirements and all network upgrades in service, all interconnection request in Group 2 will meet FERC Order #661A low voltage ride through (LVRT) requirements and the transmission system will remain stable.

Power Factor Requirements

Request	Size (MW)	Generator Model	Point of Interconnection	Final PF Requirement at POI		Estimated Capacitor Requirement (Mvar)
				Lagging (supplying)	Leading (absorbing)	
GEN-2008-047	300	G.E. 1.5MW	Tap Hitchland-Woodward 345kV	0.95	1.00	Yes (107.5 MVar)
GEN-2008-110 GEN-2010-014	300 358.8	G.E. 1.5MW Siemens 2.3MW	Hitchland 345kV	0.95	0.98	No
GEN-2010-007	73.8	Vestas V100 1.8MW	Riverside – Pringle 115kV	1.00	0.95	Yes (12.63 MVar)

Cluster Group 3 (Spearville Area)

With the power factor requirements and all network upgrades in service, all interconnection request in Group 3 will meet FERC Order #661A low voltage ride through (LVRT) requirements and the transmission system will remain stable.

Power Factor Requirements

Request	Size (MW)	Generator Model	Point of Interconnection	Final PF Requirement at POI		Estimated Capacitor Requirement (Mvar)
				Lagging (supplying)	Leading (absorbing)	
GEN-2009-059	100.5	GE 1.5MW	Tap G08-79T – Cudahay 115kV (573029-539659)	0.97	0.98	No
GEN-2010-009	165.6	Siemens SWT 2.3MW	Gray County 345kV (531000)(G07-040-POI)	0.95	0.95	Yes (136.1 MVar)
GEN-2010-015	200.1	Siemens SWT 2.3MW	Spearville 345kV (531469)	0.95	1.000	Yes (18.7 MVar)
GEN-2010-016	199.8	Vestas V90 1.8MW	Tap Spearville (531469) – Knoll (560004) 345kV	0.950	0.967	Yes (300 MVar)

Cluster Group 4 (Mingo Area)

There was no stability analysis conducted in the Mingo area due to no requests in the area.

Cluster Group 5 (Amarillo Area)

The Amarillo area stability analysis revealed no new stability issues due to the addition of the study projects. With the power factor requirements and all network upgrades in service, all interconnection request in Group 5 will meet FERC Order #661A low voltage ride through (LVRT) requirements and the transmission system will remain stable.

Power Factor Requirements

Request	Size (MW)	Generator Model	Point of Interconnection	Final PF Requirement at POI		Estimated Capacitor Requirement (Mvar)
				Lagging (supplying)	Leading (absorbing)	
GEN-2008-088	50.6	Siemens SWT 2.3MW	Vega 69kV	1.0	0.957	No

Cluster Group 6 (South Panhandle Area)

With the power factor requirements and all network upgrades in service, all interconnection request in Group 6 will meet FERC Order #661A low voltage ride through (LVRT) requirements and the transmission system will remain stable

Power Factor Requirements

Request	Size (MW)	Generator Model	Point of Interconnection	Final PF Requirement at POI		Estimated Capacitor Requirement (Mvar)
				Lagging (supplying)	Leading (absorbing)	
GEN-2008-022	300	G.E. 1.5MW	Eddy – Tolk 345kV	1.00	0.96	No
GEN-2009-067S	20	Solar	Seven Rivers 69kV	0.95	0.95	
GEN-2010-006	205	GENROU	Jones 230kV	0.95	0.95	0
ASGI-2010-010	48	GENROU	Lovington 115kV	0.95	0.95	0

Cluster Group 7 (Southwest Oklahoma)

With the power factor requirements and all network upgrades in service, all interconnection request in Group 7 will meet FERC Order #661A low voltage ride through (LVRT) requirements and the transmission system will remain stable

Power Factor Requirements

Request	Size (MW)	Generator Model	Point of Interconnection	Final PF Requirement at POI		Estimated Capacitor Requirement (Mvar)
				Lagging (supplying)	Leading (absorbing)	
GEN-2008-037	100.8	Vestas V90 1.8MW	Washita (521089)	0.96	0.93	Yes (6 MVar)
GEN-2009-030	100.8	GE 1.6MW	Weatherford 138kV (521092)	0.95	1.00	Yes (24 MVar)
GEN-2009-060	85.5	GE 1.5MW	Gotebo 69kV (520925)	1.000	0.97	No

Cluster Group 8 (South Central Kansas)

The South Central Kansas stability analysis revealed possible oscillatory issues with GEN-2008-098 and GEN-2010-003 in relation to the Wolf Creek nuclear plant. To relieve these oscillation issues, these requests will need to install a +/-15Mvar Static Var Compensator at the wind farm. With the power factor requirements, the SVCs, and all network upgrades in service, all interconnection request in Group 8 will meet FERC Order #661A low voltage ride through (LVRT) requirements and the transmission system will remain stable.

Power Factor Requirements

Request	Size (MW)	Generator Model	Point of Interconnection	Final PF Requirement at POI		Estimated Capacitor Requirement (Mvar)
				Lagging (supplying)	Leading (absorbing)	
GEN-2008-071	76.8	GE 1.6MW	Newkirk 138kV	0.95	0.95	Yes (9 MVar)
GEN-2008-098	100.8	Vestas V90	Wolf Creek – LaCygne 345kV	0.98	0.95	No
GEN-2010-003	100.8	1.8MW				
GEN-2010-005	300	Clipper C95 2.5MW	Wichita – Woodring 345kV	0.99	0.99	No
GEN-2010-013	50.4	Vestas V90 1.8MW	Latham – Neosho 345kV	0.95	0.98	Yes (54 MVar)

Cluster Group 9 (Northeast Nebraska)

With the power factor requirements and all network upgrades in service, all interconnection request in Group 9 will meet FERC Order #661A low voltage ride through (LVRT) requirements and the transmission system will remain stable.

Power Factor Requirements

Request	Size (MW)	Generator Model	Point of Interconnection	Final PF Requirement at POI		Estimated Capacitor Requirement (Mvar)
				Lagging (supplying)	Leading (absorbing)	
GEN-2006-044N02	100.5	GE 1.5MW	Madison County 230kV	1.00	0.97	No
GEN-2010-010	100.5	GE 1.5MW	Madison County 115kV	1.00	0.95	Yes (4.85 MVar)

Cluster Group 10 (North Nebraska)

There was no stability analysis conducted in the North Nebraska area due to no requests in the area.

Cluster Group 11 (North Kansas)

The North Kansas stability analysis revealed that GEN-2009-020 will require a +/-15 Mvar Static Var Compensator. With the power factor requirements, and all network upgrades in service, all interconnection request in Group 11 will meet FERC Order #661A low voltage ride through (LVRT) requirements and the transmission system will remain stable.

Power Factor Requirements

Request	Size (MW)	Generator Model	Point of Interconnection	Final PF Requirement at POI		Estimated Capacitor Requirement (Mvar)
				Lagging (supplying)	Leading (absorbing)	
GEN-2009-008	199.5	GE 1.5MW	South Hays 230kV	0.99	0.94	No
GEN-2009-020	48.6	Vestes V90 1.8MW	Balzine – Nekoma 69kV	1.0	0.98	No
GEN-2009-040	73.8	Vestes V90 1.8MW	Smittyville-Knob Hill 115kV	1.0	0.95	Yes (5 MVar)

Cluster Group 12 (Northwest Arkansas)

There was no stability analysis conducted in the Northwest Arkansas area due to no requests in the area.

Cluster Group 13 (Northwest Missouri)

There was no stability analysis conducted in the Northwest Missouri area due to no requests in the area.

Cluster Group 14 (South Central Oklahoma)

The South Central Oklahoma stability analysis revealed no stability issues with the study requests.

Power Factor Requirements

Request	Size (MW)	Generator Model	Point of Interconnection	Final PF Requirement at POI		Estimated Capacitor Requirement (Mvar)
				Lagging (supplying)	Leading (absorbing)	
GEN-2008-046	200	Vestes V90 1.8MW	Sunnyside 345kV	0.98	0.955	yes
GEN-2009-032S	6.4	GENROU	Foster 138kV	0.95	0.95	0

Cluster Group 15 (Southwest Nebraska)

The Group 15 stability analysis revealed no stability issues with the study request. With the power factor requirements and network upgrades in service, the interconnection requests will met FERC LVRT requirements and the transmission system will remain stable.

Power Factor Requirements

Request	Size (MW)	Generator Model	Point of Interconnection	Final PF Requirement		Estimated Capacitor Requirement (Mvar)
				Lagging (supplying)	Leading (absorbing)	
GEN-2008-123N	89.7	Siemens SWT 2.3 MW	Pauline – Guide Rock 115kV	1.0	0.95	Yes (7 MVAr)

Conclusion

The minimum cost of interconnecting all of the interconnection requests included in this Impact Cluster Study is estimated at \$350,000,000 for the Allocated Network Upgrades and Transmission Owner Interconnection Facilities are listed in Appendix E, F, and G. These costs do not include the cost of upgrades of other transmission facilities listed in Appendix H which are Network Constraints.

These interconnection costs do not include any cost of Network Upgrades determined to be required by short circuit analysis. These studies are being performed as part of the Interconnection System Facility Study that each customer has already executed.

The required interconnection costs listed in Appendices E, and F, and G and other upgrades associated with Network Constraints do not include all costs associated with the deliverability of the energy to final customers. These costs are determined by separate studies if the Customer submits a Transmission Service Request (TSR) through SPP's Open Access Same Time Information System (OASIS) as required by Attachment Z1 of the SPP Open Access Transmission Tariff (OATT).

Appendix

A: Generation Interconnection Requests Considered for Impact Study

Request	Amount	Area	Requested Point of Interconnection	Proposed Point of Interconnection	Requested In-Service Date
GEN-2006-044N02	100.5	NPPD	GEN-2008-086N02 230kV	TAP FORT RANDALL-KELLEY 230kV	
GEN-2008-022	300	SPS	TAP EDDY – GEN-2007-034 345kV	TAP EDDY – TOLK 345kV	09/01/2011
GEN-2008-037	100.8	WFEC	TAP WASHITA - BLUE CANYON 138kV	TAP WASHITA - BLUE CANYON 138kV	1/1/2010
GEN-2008-044	197.8	OKGE	TATONGA 345kV	TATONGA 345kV	12/1/2011
GEN-2008-046	200	OKGE	SUNNYSIDE 345kV	SUNNYSIDE 345kV	12/1/2010
GEN-2008-047	300	SPS	TAP HITCHLAND - WOODWARD 345kV	TAP HITCHLAND - WOODWARD 345kV	12/31/2012
GEN-2008-071	76.8	OKGE	NEWKIRK 138kV	NEWKIRK 138kV	11/1/2010
GEN-2008-088	50.6	SPS	VEGA 69kV	VEGA 69kV	12/1/2011
GEN-2008-098	100.8	WERE	TAP WOLF CREEK - LACYGNE 345kV	TAP WOLF CREEK - LACYGNE 345kV	12/31/2011
GEN-2008-110	299.2	SPS	HITCHLAND 345kV	HITCHLAND 345kV	7/31/2011
GEN-2008-123N	89.7	NPPD	TAP GUIDE - PAULINE 115kV	TAP GUIDE - PAULINE 115kV	
GEN-2009-008	200	SUNC	SOUTH HAYS 230kV	SOUTH HAYS 230kV	9/1/2011
GEN-2009-020	48.6	MIDW	TAP BAZINE - NEKOMA 69kV	TAP BAZINE - NEKOMA 69kV	12/31/2011
GEN-2009-030	100.8	WFEC	WEATHERFORD 138kV	WEATHERFORD 138kV	7/1/2012
GEN-2009-032S	6.4	OKGE	FOSTER 138kV	FOSTER 138kV	8/1/2010
GEN-2009-040	73.8	WERE	TAP SMITTYVILLE - KNOB HILL 115kV	TAP SMITTYVILLE - KNOB HILL 115kV	12/31/2012
GEN-2009-059	100.5	SUNC	TAP GEN-2008-079 - CUDAHY 115kV	TAP GEN-2008-079 - CUDAHY 115kV	12/31/2011
GEN-2009-060	84	WFEC	GOTEBO 69kV	GOTEBO 69kV	12/31/2011
GEN-2009-062	115	SUNC	HUGOTON 115kV	HUGOTON 115kV	9/30/2012
GEN-2009-067S	20	SPS	7 RIVERS 69kV	7 RIVERS 69kV	12/1/2010
GEN-2010-003	100.8	WERE	GEN-2008-098 345kV	GEN-2008-098 345kV	12/31/2011
GEN-2010-005	300	MKEC	GEN-2007-025 345kV	GEN-2007-025 345kV	12/1/2012
GEN-2010-006	205	SPS	JONES 230kV	JONES 230kV	6/1/2012
GEN-2010-007	73.8	SPS	TAP PRINGLE - RIVERVIEW 115kV	TAP PRINGLE - RIVERVIEW 115kV	12/1/2011
GEN-2010-008	64.4	WFEC	FARGO 69kV	FARGO 69kV	12/22/2011
GEN-2010-009	165.6	SUNC	GRAY COUNTY 345kV	GRAY COUNTY 345kV	12/1/2011
GEN-2010-010	100.5	NPPD	TAP GEN-2008-086N02 - COLUMBUS 230kV	TAP GEN-2008-086N02 - COLUMBUS 230kV	12/1/2012
GEN-2010-011	29.7	OKGE	GEN-2008-044 345kV	GEN-2008-044 345kV	12/31/2011
GEN-2010-013	50.4	WERE	GEN-2005-013 345kV	GEN-2005-013 345kV	12/31/2011
GEN-2010-014	358.8	SPS	HITCHLAND 345kV	HITCHLAND 345kV	12/13/2013
GEN-2010-015	200.1	SUNC	SPEARVILLE 345kV	SPEARVILLE 345kV	1/1/2013
GEN-2010-016	199.8	MIDW	TAP SPEARVILLE - KNOLL 345kV	TAP SPEARVILLE - KNOLL 345kV	12/31/2015
ASGI-2010-010	42	SPS	LOVINGTON 115kV	LOVINGTON 115kV	
ASGI-2010-011	48	SPS	TEXAS COUNTY 69kV	TEXAS COUNTY 69kV	
GROUPED TOTAL	4,504.2				

* Planned Facility

^ Proposed Facility

*** Electrically Remote Interconnection Requests

B: Prior Queued Interconnection Requests

Request	Amount	Area	Requested/Proposed Point of Interconnection	Status or In-Service Date
GEN-2001-014	96	WFEC	Fort Supply 138kV	On-Line
GEN-2001-026	74	WFEC	Washita 138kV	On-Line
GEN-2001-033	180	SPS	San Juan Mesa Tap 230kV	On-Line
GEN-2001-036	80	SPS	Caprock Tap 115kV	On-Line
GEN-2001-037	100	OKGE	Windfarm Switching 138kV	On-Line
GEN-2001-039A	105	MKEC	Tap Greensburg - Judson-Large 115kV	On Schedule for 2011
GEN-2001-039M	100	SUNC	Central Plains Tap 115kV	On-Line
GEN-2002-004	200	WERE	Latham 345kV	On-Line
GEN-2002-005	120	WFEC	Red Hills Tap 138kV	On-Line
GEN-2002-006	150	SPS	Texas County 115kV	IA Executed/On Schedule 12/31/2010
GEN-2002-008	240	SPS	*Hitchland 345kV	On-Line at 120MW
GEN-2002-009	80	SPS	Hansford County 115kV	On-Line
GEN-2002-022	240	SPS	Bushland 230kV	On-Line at 160MW
GEN-2002-025A	150	MKEC	Spearville 230kV	On-Line at 100MW
GEN-2003-005	100	WFEC	Tap Anadarko - Paradise 138kV	On Line
GEN-2003-006A-E	100	MKEC	Elm Creek 230kV	On-Line
GEN-2003-006A-W	100	MKEC	Elm Creek 230kV	On-Line
GEN-2003-013**	198	SPS	Tap *Hitchland - Finney 345kV	On Schedule for 2012
GEN-2003-019	250	MIDW	Smoky Hills Tap 230kV	On-Line
GEN-2003-020	160	SPS	Martin 115kV	On-Line at 80MW
GEN-2003-021N	75	NPPD	Ainsworth Wind Tap 115kV	On-Line at 60MW
GEN-2003-022	120	AEPW	Washita 138kV	On-Line
GEN-2004-005N	30	NPPD	St. Francis 115kV	IA Pending
GEN-2004-014	154.5	MIDW	Spearville 230kV	On Schedule for 2010
GEN-2004-020	27	AEPW	Washita 138kV	On-Line
GEN-2005-005	18	OKGE	Windfarm Switching 138kV	IA Pending
GEN-2005-008	120	OKGE	Woodward 138kV	On-Line
GEN-2005-012	250	SUNC	Spearville 345kV	On Suspension
GEN-2005-013	201	WERE	Tap Latham - Neosho	On Schedule for 2012
GEN-2005-015	150	SPS	Tap Tuco - Oklaunion 345kV	On Suspension
GEN-2005-017	340	SPS	Tap *Hitchland - Potter County 345kV	On Suspension
GEN-2005-021	85.5	SPS	Kirby 115kV	On Suspension
GEN-2006-002	150	AEPW	Tap Grapevine - Elk City 230kV	On Schedule for 2011
GEN-2006-006	205.5	SUNC	Spearville 230kV	IA Pending
GEN-2006-014	300	MIPU	Tap Maryville – Clarinda and tie Midway (WFARMS) 161kV	On Suspension
GEN-2006-017	300	MIPU	Tap Maryville – Clarinda and tie Midway (WFARMS) 161kV	On Suspension
GEN-2006-018	170	SPS	Tuco 230kV	On Schedule for 2010
GEN-2006-020S	18.9	SPS	*DWS Frisco Tap	IA Executed/On Schedule 12/31/2011
GEN-2006-020N	42	NPPD	Bloomfield 115kV	1/1/2009
GEN-2006-021	101	MKEC	Flat Ridge Tap 138kV	On-Line (100MW)

B-1

Definitive Interconnection System Impact Study for Grouped Generation Interconnection Requests – (DISIS-2010-001)

SPP RESTRICTED

Request	Amount	Area	Requested/Proposed Point of Interconnection	Status or In-Service Date
GEN-2006-022	150	MKEC	Ninnescah Tap 115kV	On Suspension
GEN-2006-024S	19.8	WFEC	South Buffalo Tap 69kV	On-Line
GEN-2006-026	502	SPS	Hobbs 230kV	On-Line
GEN-2006-031	75	MIDW	Knoll 115kV	On-Line
GEN-2006-032	200	MIDW	South Hays 230kV	On Suspension
GEN-2006-034	81	SUNC	Tap Kanarado - Sharon Springs 115kV	On Suspension
GEN-2006-035	225	AEPW	Tap Grapevine - Elk City 230kV	On Schedule for 2010
GEN-2006-037N1	75	NPPD	Broken Bow 115kV	Under Study (DISIS-2009-001)
GEN-2006-038N005	80	NPPD	Broken Bow 115kV	On Schedule for 2012
GEN-2006-038N019	80	NPPD	Petersburg 115kV	5/1/2011
GEN-2006-038	750	WFEC	Hugo 345kV	On Suspension
GEN-2006-039	400	SPS	Tap and Tie both Potter County - Plant X 230kV and Bushland - Deaf Smith 230kV	On Suspension
GEN-2006-040	108	SUNC	Mingo 115kV	On Schedule for 2010
GEN-2006-043	99	AEPW	Tap Grapevine - Elk City 230kV	On Line
GEN-2006-044	370	SPS	*Hitchland 345kV	On Suspension
GEN-2006-044N	40.5	NPPD	Tap Neligh – Petersburg 115kV	On Schedule for 2011
GEN-2006-045	240	SPS	Tap and Tie both Potter County - Plant X 230kV and Bushland - Deaf Smith 230kV	On Suspension
GEN-2006-046	131	OKGE	Dewey 138kV	On Schedule for 2010
GEN-2006-047	240	SPS	Tap and Tie both Potter County - Plant X 230kV and Bushland - Deaf Smith 230kV	On Schedule for 2013
GEN-2006-049	400	SPS	Tap *Hitchland - Finney 345kV	On Schedule for 2014
GEN-2007-002	160	SPS	Grapevine 115kV	On Suspension
GEN-2007-006	160	OKGE	Roman Nose 138kV	On Suspension
GEN-2007-011	135	SUNC	Syracuse 115kV	On Schedule for 2010
GEN-2007-011N06	75	NPPD	Tap Neligh - Petersburg 115kV	IA Pending
GEN-2007-011N08	81	NPPD	Bloomfield 115kV	On-Line
GEN-2007-011N09	75	NPPD	Bloomfield 115kV	IA Pending
GEN-2007-013	99	SUNC	Selkirk 115kV	On Suspension
GEN-2007-015	135	WERE	Tap Humboldt – Kelly 161kV	On Suspension
GEN-2007-017	100.5	MIPU	Tap Maryville – Clarinda and tie to Midway (WFARMS)161kV	On Suspension
GEN-2007-021	201	OKGE	*Tatonga 345kV	IA Pending
GEN-2007-025	300	WERE	Tap Woodring – Wichita 345kV	IA Pending
GEN-2007-032	150	WFEC	Tap Clinton Junction – Clinton 138kV	IA Pending
GEN-2007-038	200	SUNC	Spearville 345kV	IA Pending
GEN-2007-040	200.1	SUNC	Tap Holcomb – Spearville 345kV	Under Study (DISIS-2009-001)
GEN-2007-043	200	AEPW	Tap Lawton Eastside – Cimarron 345kV	On Line
GEN-2007-044	300	OKGE	*Tatonga 345kV	IA Pending
GEN-2007-046	199.5	SPS	Tap & Tie Texas County – Hitchland & DWS Frisco Tap – Hitchland 115kV	On Schedule for 2014

Request	Amount	Area	Requested/Proposed Point of Interconnection	Status or In-Service Date
GEN-2007-048	400	SPS	Tap Amarillo South – Swisher 230kV	On Schedule for 2014
GEN-2007-050	170	OKGE	*Woodward 138kV	On Line
GEN-2007-051	200	WFEC	Mooreland 138kV	On Schedule for 2014
GEN-2007-052	150	WFEC	Anadarko 138kV	On Line
GEN-2007-053	110	MIPU	Tap Maryville – Clarinda and tie to Midway (WFARMS)161kV	On Schedule for 2013
GEN-2007-057	34.5	SPS	Moore County East 115kV	On Schedule for 2014
GEN-2007-062**	765	OKGE	*Woodward 345kV	On Schedule for 2014
GEN-2008-003	101	OKGE	*Woodward EHV 138kV	IA Pending
GEN-2008-008	60	SPS	Graham 115kV	On Schedule for 2014
GEN-2008-009	60	SPS	San Juan Mesa Tap 230kV	On Schedule for 2014
GEN-2008-013	300	OKGE	Tap Woodring – Wichita 345kV	On Schedule for 2013
GEN-2008-014	150	SPS	Tap Tuco – Oklaunion 345kV	On Schedule for 2014
GEN-2008-016	248	SPS	Grassland 230kV	IA Pending
GEN-2008-017	300	SUNC	Setab 345kV	IA Pending
GEN-2008-018	405	SUNC	Finney 345kV	IA Pending
GEN-2008-019**	300	OKGE	*Tatonga 345kV	IA Pending
GEN-2008-021	42	WERE	Wolf Creek 345kV	IA Pending
GEN-2008-023	150	AEPW	Hobart Junction 138kV	IA Pending
GEN-2008-025	101.2	SUNC	Ruleton 115kV	IA Pending
GEN-2008-029	250.5	OKGE	Woodward EHV 138kV	IA Pending
GEN-2008-038	150	AEPW	Tap Shidler – West Pawhuska 138kV	IA Pending
GEN-2008-051	322	SPS	Potter 345kV	IA Pending
GEN-2008-079	100.5	MKEC	Tap Judson Large – Cudahy 115kV	IA Pending
GEN-2008-086N02	200	NPPD	Tap Ft. Randall – Columbus 230kV	IA Pending
GEN-2008-092	201	MIDW	Knoll 115kV	IA Pending
GEN-2008-119O	60	OPPD	Tap Humboldt – Kelly (North of GEN-2007-015) 161kV	On Schedule
GEN-2008-124	200.1	SUNC	Spearville 230kV	IA Pending
GEN-2008-127	200.1	WERE	Tap Sooner – Rose Hill 345kV	IA Pending
GEN-2008-129	46S/80W	MIPU	Pleasant Hill 161kV	On Line
GEN-2009-011	50	MKEC	Tap Plainville – Phillipsburg 115kV	IA Pending
GEN-2009-016	141	AEPW	Falcon Road 138kV	IA Pending
GEN-2009-017**	60	SPS	Tap Pembroke – Stiles 138kV	Under Study (DISIS-2009-001)
GEN-2009-025	60	OKGE	Tap Deer Creek – Sinclair 69kV	IA Pending
Broken Bow	8.3	NPPD	Genoa 115kV	On-Line
Ord	13.9	NPPD	Bloomfield 115kV	On-Line
Stuart	2.1	NPPD	Petersburg 115kV	On-Line
Genoa	4	NPPD	Genoa 115kV	On-Line
ASGI-2010-001	400	AECI	Tap Cooper – Fairport 345kV	AECI queue Affected Study
ASGI-2010-002	201	AECI	Lathrop 161kV	AECI queue Affected Study
ASGI-2010-003	300	AECI	Maryville 161kV	AECI queue Affected Study
ASGI-2010-004	50	AECI	Tap Queen City – Lancaster 69kV	AECI queue Affected Study

Request	Amount	Area	Requested/Proposed Point of Interconnection	Status or In-Service Date
ASGI-2010-005	99	AECI	Lathrop 161kV	AECI queue Affected Study
ASGI-2010-006	150	AECI	Tap Fairfax – Fairfax Tap 138kV	AECI queue Affected Study
ASGI-2010-007	150	AECI	Tap Fairfax – Fairfax Tap 138kV	AECI queue Affected Study
ASGI-2010-008	100	AECI	Maryville 161kV	AECI queue Affected Study
ASGI-2010-009	201	AECI	Osborn 161kV	AECI queue Affected Study
Llanoest	80	SPS	Llano Wind Farm Tap 115kV	On-Line
SPSDISTR	90	SPS	DUMAS_19ST 115kV	On-Line
			Etter 115kV	On-Line
			Sherman 115kV	On-Line
			Spearman 115kV	On-Line
			Texas County 115kV	On-Line
BLUCAN2	153	WFEC	Washita 138kV (GEN-2003-004)	On-Line
			Washita 138kV (GEN-2004-023)	On-Line
			Washita 138kV (GEN-2005-003)	On-Line
Monte	110	MKEC	Haggard 115kV	On-Line
GROUPED TOTAL	20,953			

** Interconnection on Caprock Electric tested for impacts on SPP

* Planned Facility

^ Proposed Facility

C: Study Groupings

Cluster	Request	Amount	Area	Proposed Point of Interconnection
Prior Queued	GEN-2001-014	96	WFEC	Fort Supply 138kV
	GEN-2001-037	100	OKGE	Windfarm Switching 138kV
	GEN-2002-005	120	WFEC	Tap Morewood - Elk City 138kV
	GEN-2005-005	18	OKGE	Windfarm Tap 138kV
	GEN-2005-008	120	OKGE	Woodward 138kV
	GEN-2006-024S	19.8	WFEC	South Buffalo Tap 69kV
	GEN-2006-046	131	OKGE	Dewey 138kV
	GEN-2007-006	160	OKGE	Roman Nose 138kV
	GEN-2007-021	201	OKGE	*Tatonga 345kV
	GEN-2007-044	300	OKGE	*Tatonga 345kV
	GEN-2007-050	170	OKGE	*Woodward 345kV
	GEN-2007-051	200	WFEC	Mooreland 138kV
	GEN-2007-062	765	OKGE	*Woodward 345kV
	GEN-2008-003	101	OKGE	*Woodward EHV 138kV
GEN-2008-019	300	OKGE	*Tatonga 345kV	
GEN-2008-029	250.5	OKGE	WOODWARD EHV 138kV	
PRIOR QUEUED SUBTOTAL		3,052.3		
Cluster	Request	Amount	Area	Proposed Point of Interconnection
Woodward	GEN-2008-044	197.8	OKGE	Tatonga 345kV
	GEN-2010-008	64.4	WFEC	Fargo 69kV
	GEN-2010-011	29.7	OKGE	GEN-2008-044 345kV
WOODWARD SUBTOTAL		291.9		
AREA SUBTOTAL		3,344.4		

Cluster	Request	Amount	Area	Proposed Point of Interconnection
Prior Queued	SPS Distribution	90	SPS	Various
	GEN-2002-006	150	SPS	Texas County 115kV
	GEN-2002-008	240	SPS	*Hitchland 345kV
	GEN-2002-009	80	SPS	Hansford County 115kV
	GEN-2003-013	198	SPS	*Tap Hitchland - Finney 345kV
	GEN-2003-020	160	SPS	Martin 115kV
	GEN-2005-017	340	SPS	*Tap Hitchland - Potter County 345kV
	GEN-2006-020S	18.9	SPS	DWS Frisco Tap
	GEN-2006-044	370	SPS	*Hitchland 345kV
	GEN-2006-049	400	SPS	*Tap Hitchland - Finney 345kV
	GEN-2007-046	199.5	SPS	Tap & Tie Texas County – Hitchland & DWS Frisco Tap – Hitchland 115kV
	GEN-2007-057	34.5	SPS	Moore County East 115kV
PRIOR QUEUED SUBTOTAL		2,280.9		
Cluster	Request	Amount	Area	Proposed Point of Interconnection
Hitchland	GEN-2008-047	300	SPS	TAP HITCHLAND - WOODWARD 345kV
	GEN-2008-110	299.2	SPS	Hitchland 345kV
	GEN-2010-007	73.8	SPS	Tap Pringle – Riverview 115kV
	GEN-2010-014	358.8	SPS	Hitchland 345kV
	ASGI-2010-011	48	SPS	Texas County 69kV
HITCHLAND SUBTOTAL		1,079.8		
AREA SUBTOTAL		3,660.7		

Cluster	Request	Amount	Area	Proposed Point of Interconnection
Prior Queued	Montezuma	110	MKEC	Haggard 115kV
	GEN-2001-039A	105	MKEC	Tap Greensburg - Judson-Large 115kV
	GEN-2002-025A	150	MKEC	Spearville 230kV
	GEN-2004-014	154.5	MIDW	Spearville 230kV
	GEN-2005-012	250	SUNC	Spearville 345kV
	GEN-2006-006	205.5	SUNC	Spearville 230kV
	GEN-2006-021	101	MKEC	Flat Ridge Tap 138kV
	GEN-2006-022	150	MKEC	Ninnescah Tap 115kV
	GEN-2007-038	200	SUNC	Spearville 345kV
	GEN-2007-040	200.1	SUNC	Tap Holcomb – Spearville 345kV
	GEN-2008-018	405	SUNC	Finney 345kV
	GEN-2008-079	100.5	MKEC	Tap Judson Large – Cudahy 115kV
	GEN-2008-124	200.1	SUNC	Spearville 230kV
PRIOR QUEUED SUBTOTAL		2,331.7		
Cluster	Request	Amount	Area	Proposed Point of Interconnection
Spearville	GEN-2009-059	100.5	SUNC	Tap GEN-2008-079 – Cudahy 115kV
	GEN-2009-062	115	SUNC	Hugoton 115kV
	GEN-2010-009	165.6	SUNC	Gray County 345kV
	GEN-2010-015	200.1	SUNC	Spearville 345kV
	GEN-2010-016	199.8	MIDW	Tap Spearville – Knoll 345kV
SPEARVILLE SUBTOTAL		781		
AREA SUBTOTAL		3,112.7		
Cluster	Request	Amount	Area	Proposed Point of Interconnection
Prior Queued	GEN-2001-039M	100	SUNC	Tap Leoti - City Services 115kV
	GEN-2006-034	81	SUNC	Tap Kanarado - Sharon Springs 115kV
	GEN-2006-040	108	SUNC	Mingo 115kV
	GEN-2007-011	135	SUNC	Syracuse 115kV
	GEN-2007-013	99	SUNC	Selkirk 115kV
	GEN-2008-017	300	SUNC	Setab 345kV
	GEN-2008-025	101.2	SUNC	Ruleton 115kV
PRIOR QUEUED SUBTOTAL		924.2		
MINGO/NW KANSAS SUBTOTAL		924.2		

Cluster	Request	Amount	Area	Proposed Point of Interconnection
Prior Queued	Llano Estacado	80	SPS	Llano Estacado Tap 115kV
	GEN-2002-022	240	SPS	Bushland 230kV
	GEN-2005-021	85.5	SPS	Kirby 115kV
	GEN-2006-039	400	SPS	Tap and Tie both Potter County - Plant X 230kV and Bushland - Deaf Smith 230kV
	GEN-2006-045	240	SPS	Tap and Tie both Potter County - Plant X 230kV and Bushland - Deaf Smith 230kV
	GEN-2006-047	240	SPS	Tap and Tie both Potter County - Plant X 230kV and Bushland - Deaf Smith 230kV
	GEN-2007-002	160	SPS	Grapevine 115kV
	GEN-2007-048	400	SPS	Tap Amarillo South – Swisher 230kV
GEN-2008-051	322	SPS	Potter 345kV	
PRIOR QUEUED SUBTOTAL		2,167.5		
Cluster	Request	Amount	Area	Proposed Point of Interconnection
Amarillo	GEN-2008-088	50.6	SPS	Vega 69kV
AMARILLO SUBTOTAL		50.6		
AREA SUBTOTAL		2,218.6		

Cluster	Request	Amount	Area	Proposed Point of Interconnection
Prior Queued	GEN-2001-033	180	SPS	San Juan Mesa Tap 230kV
	GEN-2001-036	80	SPS	Norton 115kV
	GEN-2005-015	150	SPS	Tap Tuco - Oklaunion 345kV
	GEN-2006-018	170	SPS	Tuco 230kV
	GEN-2006-026	502	SPS	Hobbs 230kV
	GEN-2008-008	60	SPS	Graham 115kV
	GEN-2008-009	60	SPS	San Juan Mesa Tap 230kV
	GEN-2008-014	150	SPS	Tap Tuco – Oklaunion 345kV
	GEN-2008-016	248	SPS	Grassland 230kV
GEN-2009-017	60	SPS	Tap Pembroke – Stiles 138kV	
PRIOR QUEUED SUBTOTAL		1,660		
Cluster	Request	Amount	Area	Proposed Point of Interconnection
S Pandle	GEN-2008-022	300	SPS	Tap Eddy – GEN-2007-034 345kV
	GEN-2009-067S	20	SPS	7 Rivers 69kV
	GEN-2010-006	205	SPS	Jones 345kV
	ASGI-2010-010	42	SPS	Lovington 115kV
SOUTH PANHANDLE/NM SUBTOTAL		567		
AREA SUBTOTAL		2,227		

Cluster	Request	Amount	Area	Proposed Point of Interconnection
Prior Queued	GEN-2001-026	74	WFEC	Washita 138kV
	GEN-2003-004	101	WFEC	Washita 138kV
	GEN-2003-005	100	WFEC	Anadarko - Paradise 138kV
	GEN-2003-022	120	AEPW	Washita 138kV
	GEN-2004-020	27	AEPW	Washita 138kV
	GEN-2004-023	21	WFEC	Washita 138kV
	GEN-2005-003	31	WFEC	Washita 138kV
	GEN-2006-002	150	AEPW	Grapevine - Elk City 230kV
	GEN-2006-035	225	AEPW	Grapevine - Elk City 230kV
	GEN-2006-043	99	AEPW	Grapevine - Elk City 230kV
	GEN-2007-032	150	WFEC	Tap Clinton Junction – Clinton 138kV
	GEN-2007-043	200	AEPW	Tap Lawton Eastside – Cimarron 345kV
	GEN-2007-052	150	WFEC	Anadarko 138kV
	GEN-2008-023	150	AEPW	Hobart Junction 138kV
GEN-2009-016	141	AEPW	Falcon Road 138kV	
PRIOR QUEUED SUBTOTAL		1,739		
Cluster	Request	Amount	Area	Proposed Point of Interconnection
SW Oklahoma	GEN-2008-037	100.8	WFEC	Tap Washita – Blue Canyon 138kV
	GEN-2009-030	100.8	WFEC	Weatherford 138kV
	GEN-2009-060	84	WFEC	Gotebo 69kV
SW OKLAHOMA SUBTOTAL		285.6		
AREA SUBTOTAL		2,024.6		

Cluster	Request	Amount	Area	Proposed Point of Interconnection
Prior Queued	ASGI-2010-006	150	AECI	Tap Fairfax – Fairfax Tap 138kV
	ASGI-2010-007	150	AECI	Tap Fairfax – Fairfax Tap 138kV
	GEN-2002-004	200	WERE	Latham 345kV
	GEN-2005-013	201	WERE	Tap Latham - Neosho
	GEN-2007-025	300	WERE	Tap Woodring – Wichita 345kV
	GEN-2008-013	300	OKGE	Tap Woodring – Wichita 345kV
	GEN-2008-021	42	WERE	Wolf Creek 345kV
	GEN-2008-038	150	AEPW	Tap Shidler – West Pawhuska 138kV
	GEN-2008-127	200.1	WERE	Tap Sooner – Rose Hill 345kV
	GEN-2009-025	60	OKGE	Tap Deer Creek – Sinclair 69kV
PRIOR QUEUED SUBTOTAL		1,753.1		
Cluster	Request	Amount	Area	Proposed Point of Interconnection
North Oklahoma	GEN-2008-071	76.8	OKGE	Newkirk 138kV
	GEN-2008-098	100.8	WERE	Tap Wolf Creek – LaCygne 345kV
	GEN-2010-003	100.8	WERE	GEN-2008-098 345kV
	GEN-2010-005	300	MKEC	GEN-2007-025 345kV
	GEN-2010-013	50.4	WERE	GEN-2005-013 345kV
NORTH OKLAHOMA SUBTOTAL		628.8		
AREA SUBTOTAL		2,381.9		

Cluster	Request	Amount	Area	Proposed Point of Interconnection
Prior Queued	Genoa	4	NPPD	Genoa 115kV
	GEN-2006-020N	42	NPPD	Bloomfield 115kV
	GEN-2006-038N019	80	NPPD	Petersburg 115kV
	GEN-2006-044N	40.5	NPPD	Tap Neligh – Petersburg 115kV
	GEN-2007-011N06	75	NPPD	Tap Neligh – Petersburg 115kV
	GEN-2007-011N08	81	NPPD	Bloomfield 115kV
	GEN-2007-011N09	75	NPPD	Bloomfield 115kV
	GEN-2008-086N02	200	NPPD	Tap Ft. Randall – Columbus 230kV
PRIOR QUEUED SUBTOTAL		597.5		
Cluster	Request	Amount	Area	Proposed Point of Interconnection
NE Nebraska	GEN-2006-044N02	100.5	NPPD	GEN-2008-086N02 230kV
	GEN-2010-010	100.5	NPPD	TAP GEN-2008-086N02 - COLUMBUS 230kV
NE NEBRASKA SUBTOTAL		201		
AREA SUBTOTAL		798.5		

Cluster	Request	Amount	Area	Proposed Point of Interconnection
Prior Queued	Broken Bow	8.3	NPPD	Genoa 115kV
	Ord	13.9	NPPD	Bloomfield 115kV
	Stuart	2.1	NPPD	Petersburg 115kV
	GEN-2003-021N	75	NPPD	Ainsworth Wind Tap 115kV
	GEN-2004-005N	30	NPPD	St. Francis 115kV
	GEN-2006-037N1	75	NPPD	Broken Bow 115kV
	GEN-2006-038N005	80	NPPD	Broken Bow 115kV
PRIOR QUEUED SUBTOTAL		284.3		
NORTH NEBRASKA SUBTOTAL		284.3		

Cluster	Request	Amount	Area	Proposed Point of Interconnection
Prior Queued	GEN-2003-006A-E	100	EMDE	Elm Creek 230kV
	GEN-2003-006A-W	100	WERE	Elm Creek 230kV
	GEN-2003-019	250	MIDW	Smoky Hills Tap 230kV
	GEN-2006-031	75	MIDW	Knoll 115kV
	GEN-2006-032	200	MIDW	South Hays 230kV
	GEN-2008-092	201	MIDW	Knoll 115kV
	GEN-2009-011	50	MKEC	Tap Plainville – Phillipsburg 115kV
PRIOR QUEUED SUBTOTAL		976		
Cluster	Request	Amount	Area	Proposed Point of Interconnection
North Kansas	GEN-2009-008	200	SUNC	South Hays 230kV
	GEN-2009-020	48.6	MIDW	Tap Balzine – Nekoma 69kV
	GEN-2009-040	73.8	WERE	Tap Smittyville – Knob Hill 115kV
NORTH KANSAS SUBTOTAL		322.4		
AREA SUBTOTAL		1,298.4		

Cluster	Request	Amount	Area	Proposed Point of Interconnection
Prior Queued	ASGI-2010-001	400	AECI	Tap Cooper – Fairport 345kV
	ASGI-2010-002	201	AECI	Lathrop 161kV
	ASGI-2010-003	300	AECI	Maryville 161kV
	ASGI-2010-004	50	AECI	Tap Queen City – Lancaster 69kV
	ASGI-2010-005	99	AECI	Lathrop 161kV
	ASGI-2010-008	100	AECI	Maryville 161kV
	ASGI-2010-009	201	AECI	Osborn 161kV
	GEN-2006-014	300	MIPU	Maryville – Clarinda 161kV & Tie to Midway 161kV
	GEN-2006-017	300	MIPU	Maryville – Clarinda 161kV & Tie to Midway 161kV
	GEN-2007-015	135	WERE	Tap Humboldt – Kelly 161kV
	GEN-2007-017	100.5	MIPU	Maryville – Clarinda 161kV & Tie to Midway 161kV
	GEN-2007-053	110	MIPU	Maryville – Clarinda 161kV & Tie to Midway 161kV
	GEN-2008-1190	60	OPPD	Tap Humboldt – Kelly 161kV
	GEN-2008-129	80	MIPU	Pleasant Hill 161kV
PRIOR QUEUED SUBTOTAL		2,436.5		
NORTHWEST MISSOURI SUBTOTAL		2,436.5		

Cluster	Request	Amount	Area	Proposed Point of Interconnection
Prior Queued	GEN-2006-038	750	WFEC	Hugo 345kV
PRIOR QUEUED SUBTOTAL		750		
Cluster	Request	Amount	Area	Proposed Point of Interconnection
South Central Oklahoma	GEN-2008-046	200	OKGE	Sunnyside 345kV
	GEN-2009-032S	6.4	OKGE	Foster 138kV
SOUTH CENTRAL OKLAHOMA SUBTOTAL		206.4		
AREA SUBTOTAL		956.4		

Cluster	Request	Amount	Area	Proposed Point of Interconnection
Southwest Nebraska	GEN-2008-123N	89.7	NPPD	Tap Guide – Pauline 115kV
SOUTHWEST NEBRASKA SUBTOTAL		89.7		
AREA SUBTOTAL		89.7		
***CLUSTERED TOTAL (w/o PRIOR QUEUED)		4,804.2		
***CLUSTERED TOTAL (w/PRIOR QUEUED)		25,757.2		

- * Planned Facility
- ^ Proposed Facility
- ** Alternate requests - counted as one request for study purpose
- *** Electrically Remote Interconnection Requests included in total

D: Proposed Point of Interconnection One line Diagrams

Refer to the separately posted Facility Study for each request for the most up to date one-line. If the Facility Study is not yet posted, these diagrams are the latest available.

GEN-2006-044N02

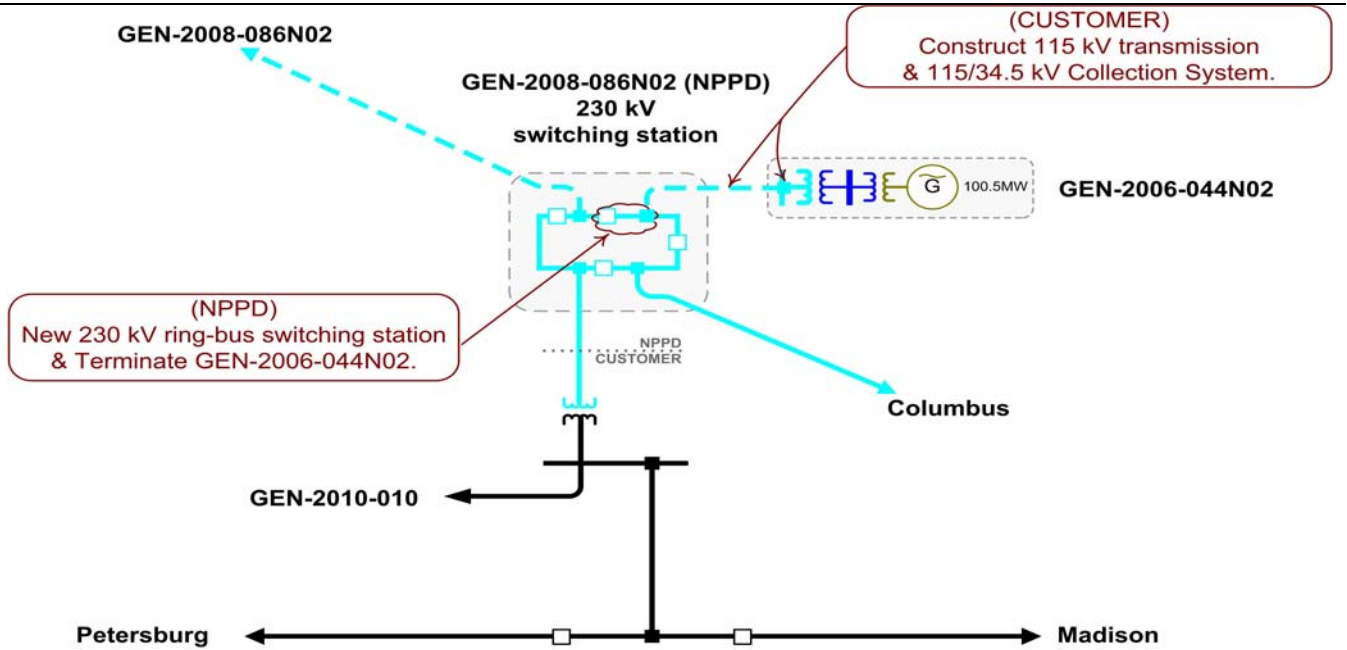

GEN-2008-022

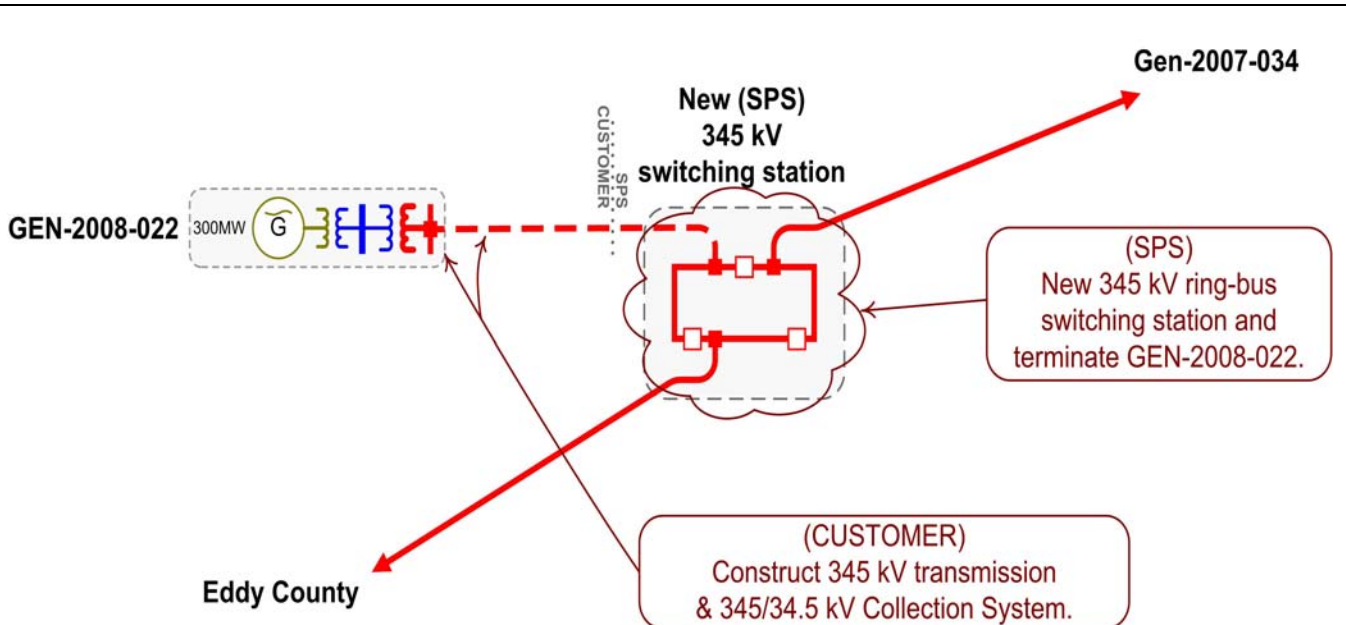

D-1

GEN-2008-037

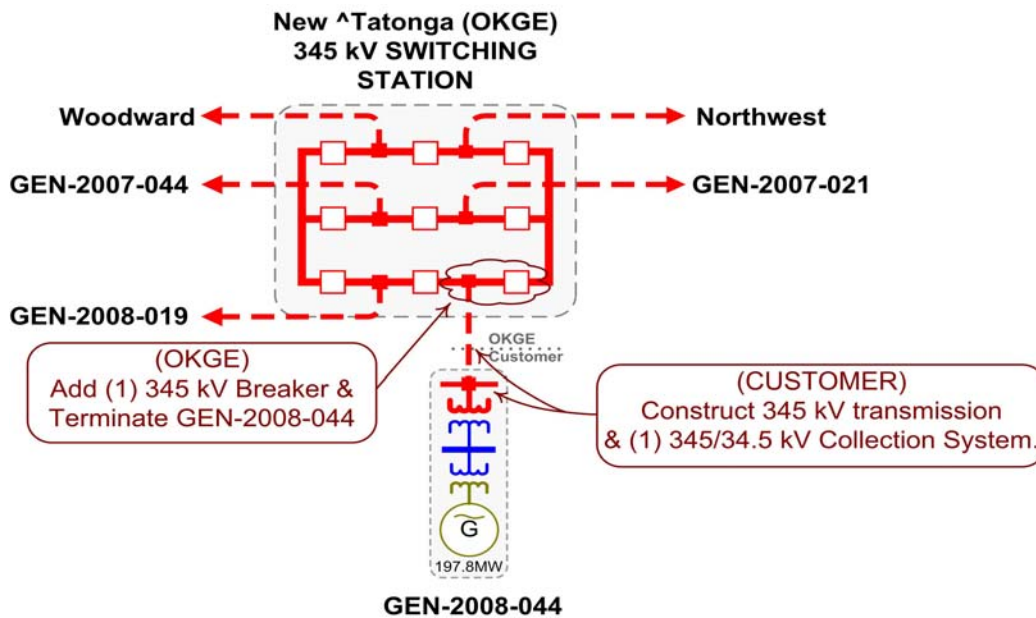
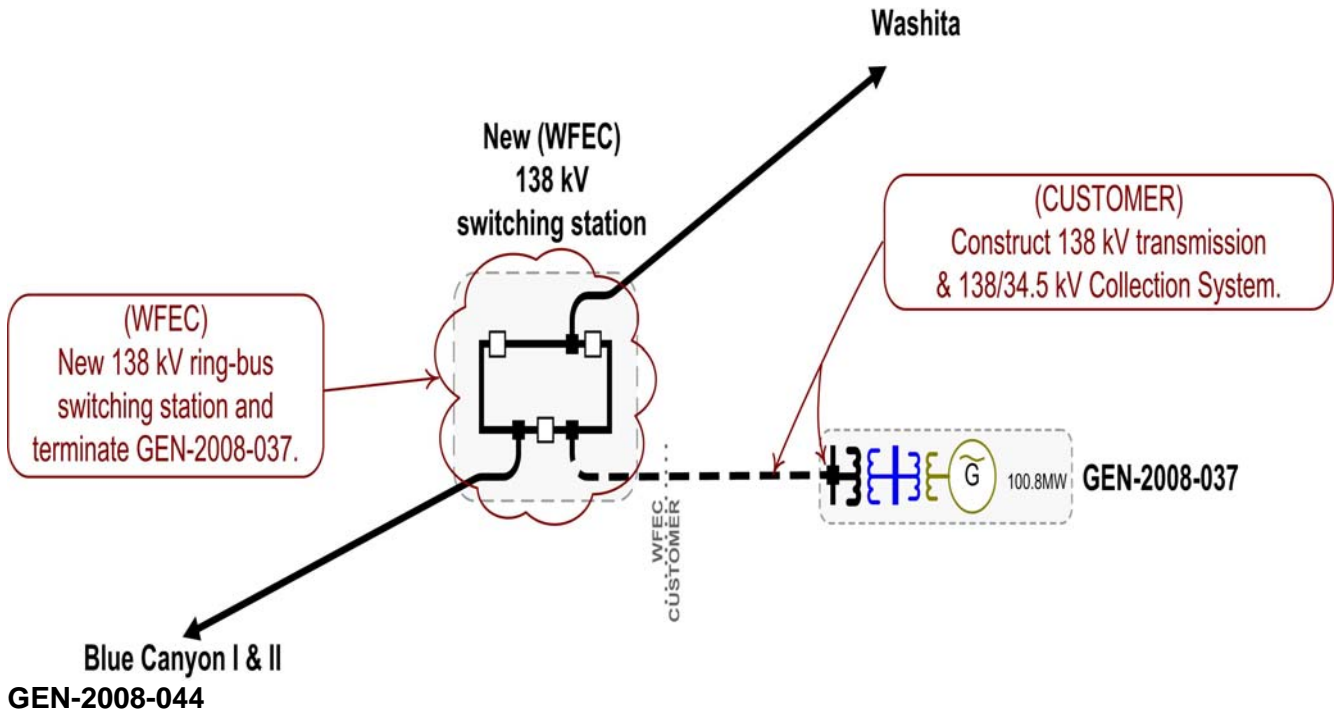

* Planned ^ Proposed

GEN-2008-046

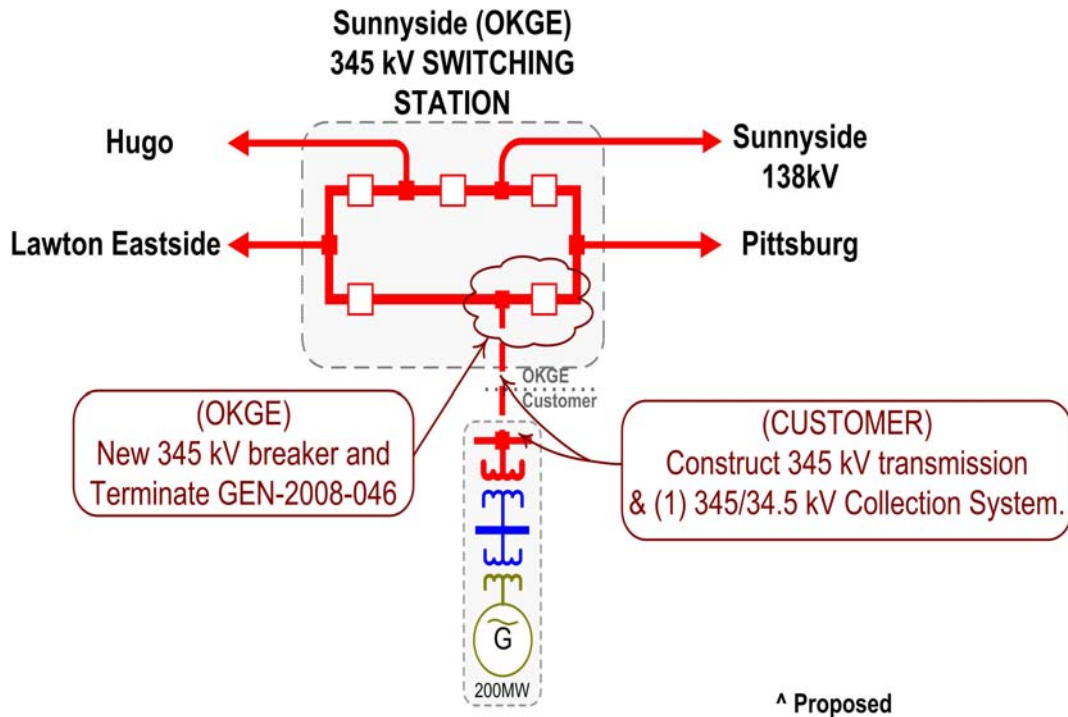

GEN-2008-046

GEN-2008-047

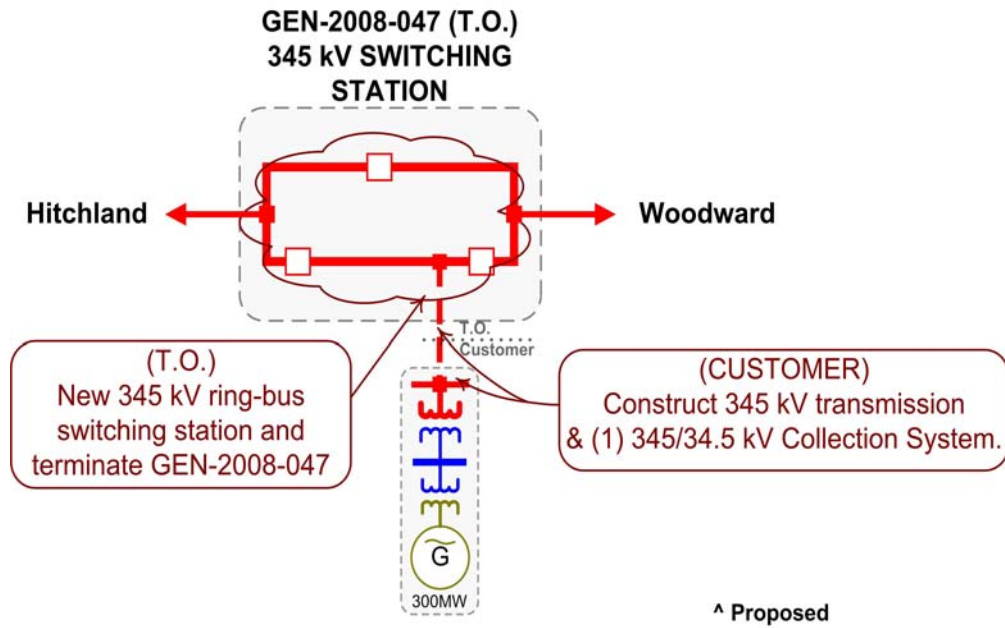

GEN-2008-047

GEN-2008-071

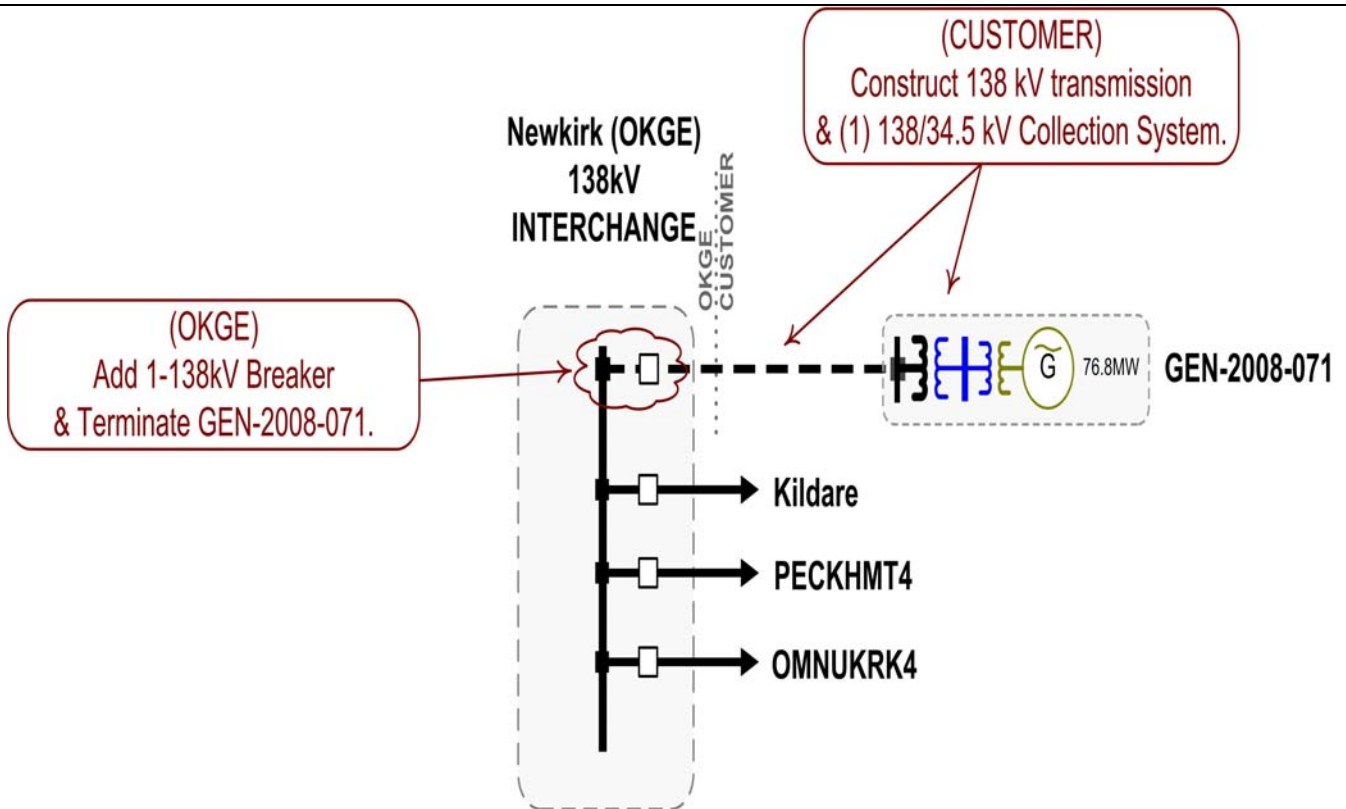

GEN-2008-088

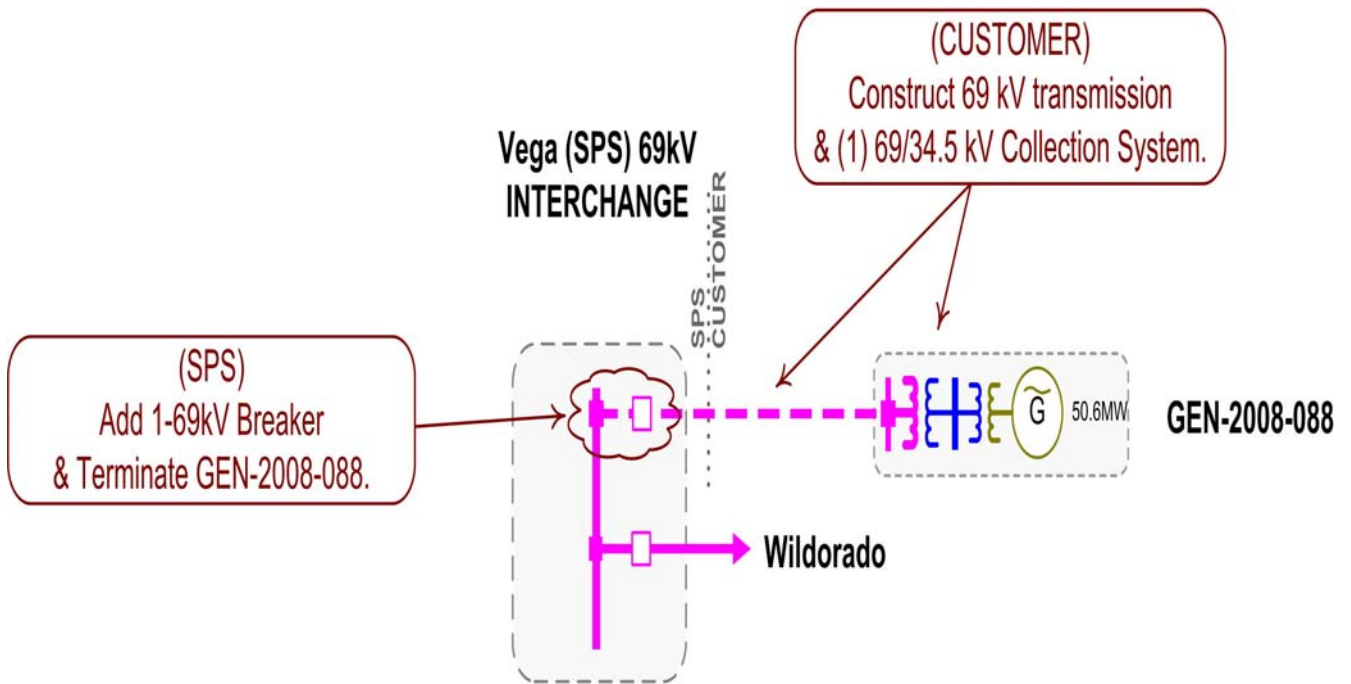

GEN-2008-098

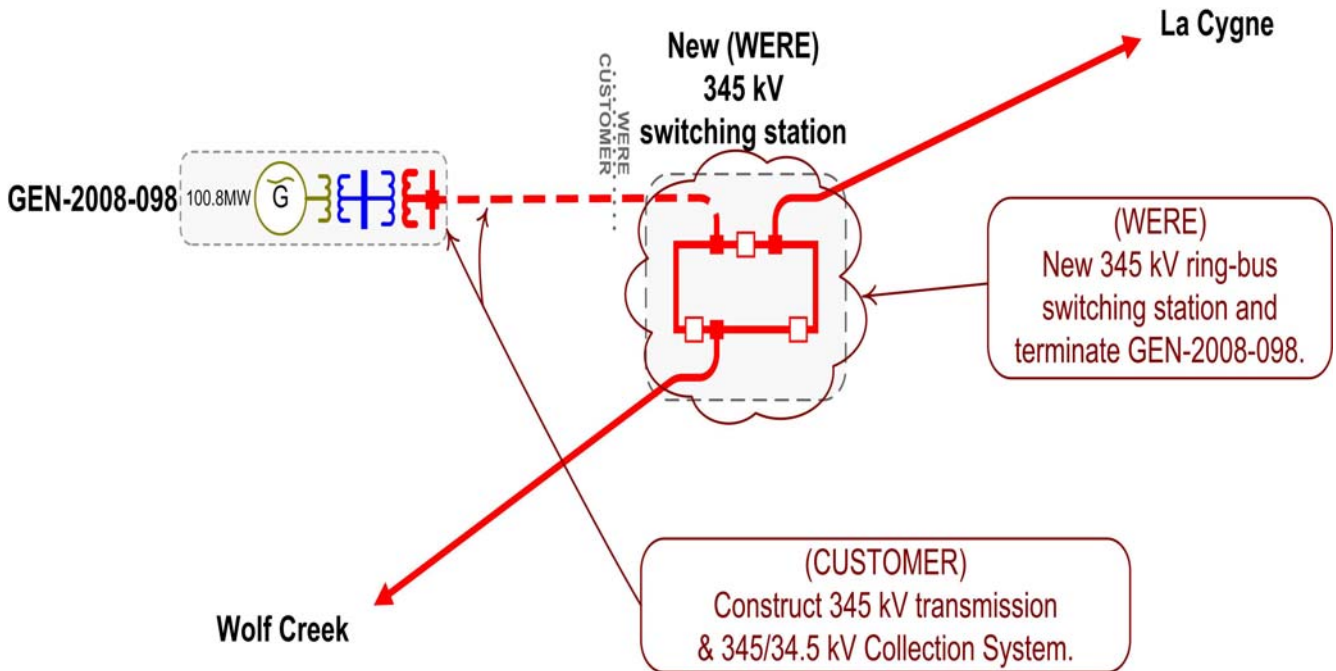

GEN-2008-110

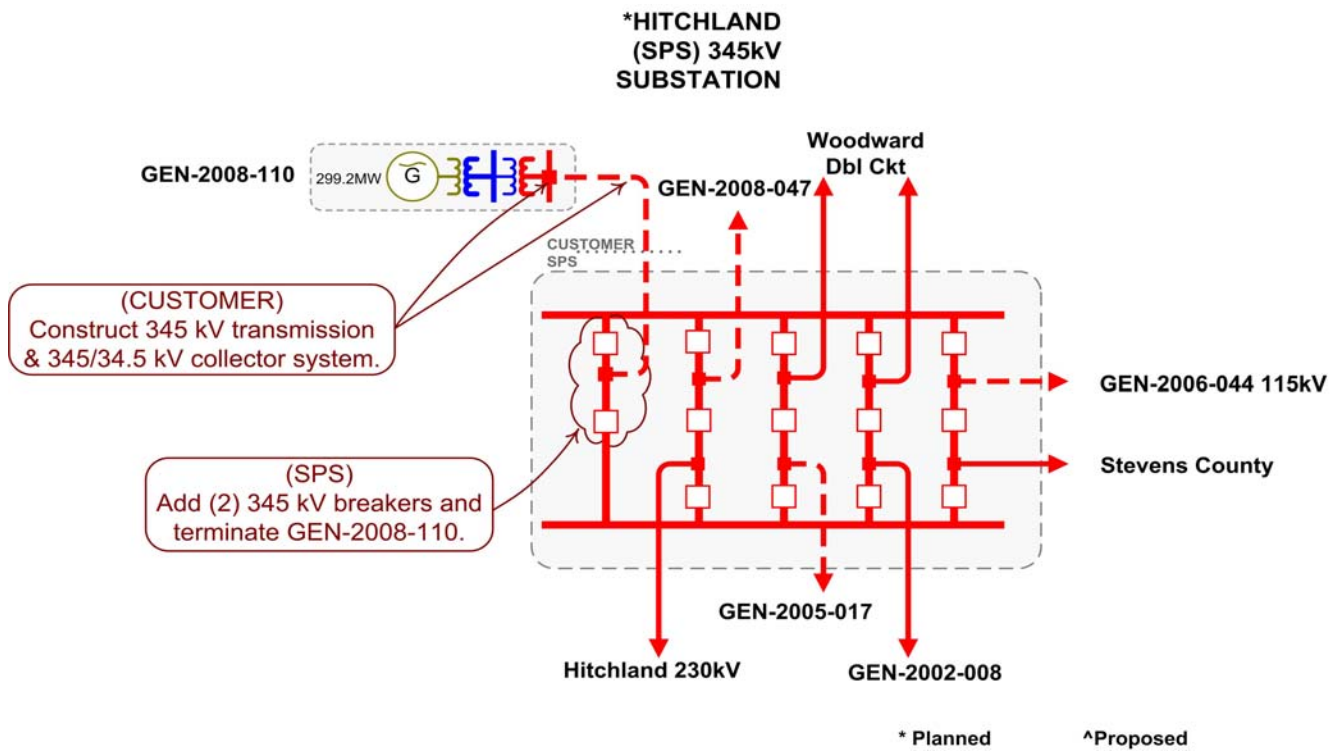

GEN-2008-123N

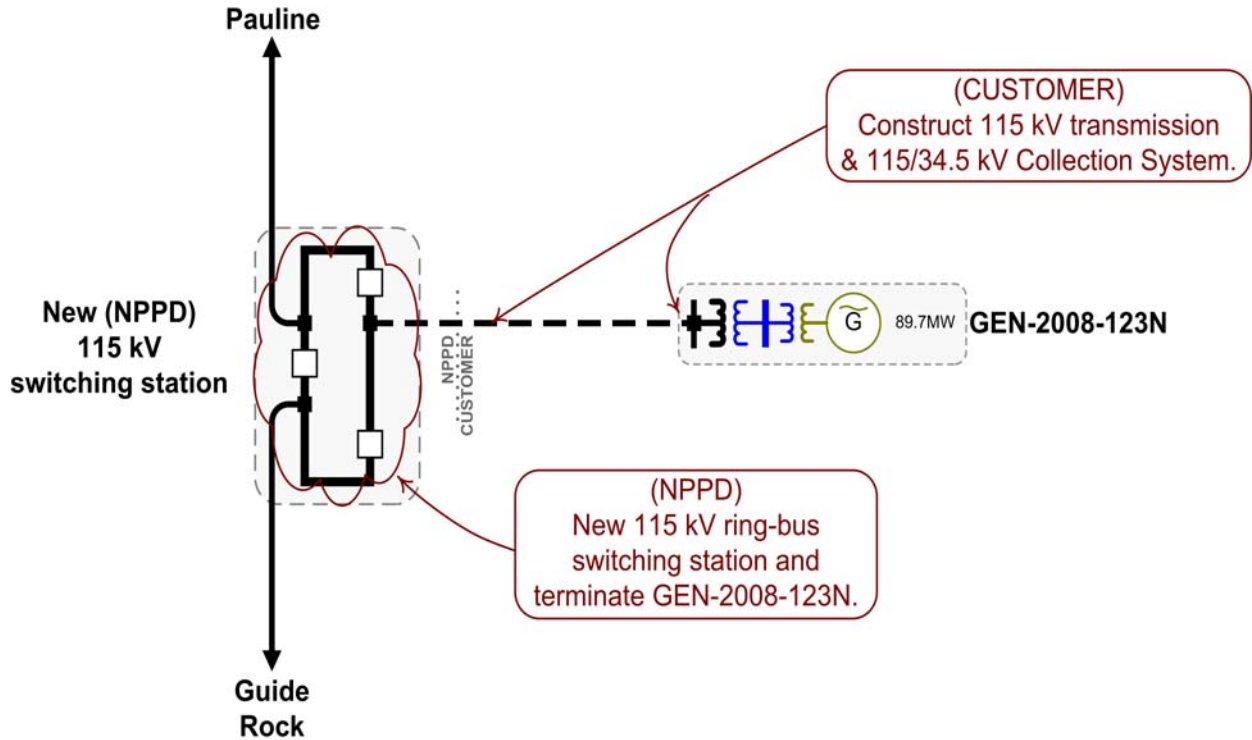

GEN-2009-008

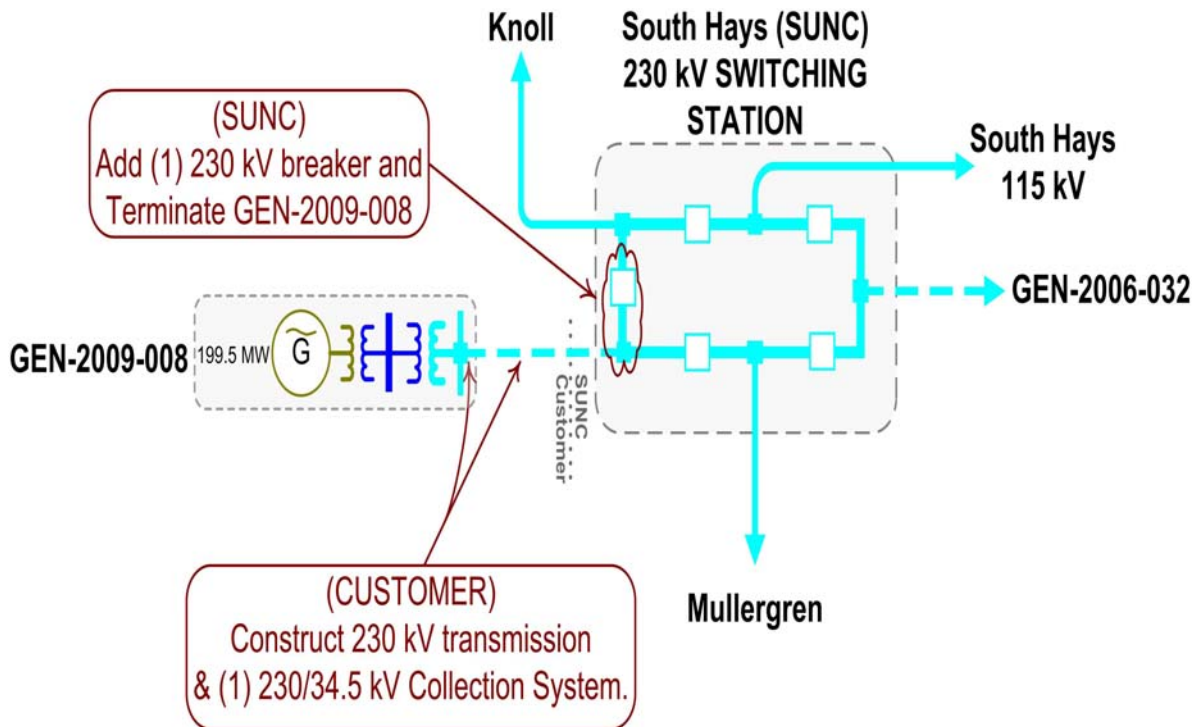

D-6

GEN-2009-020

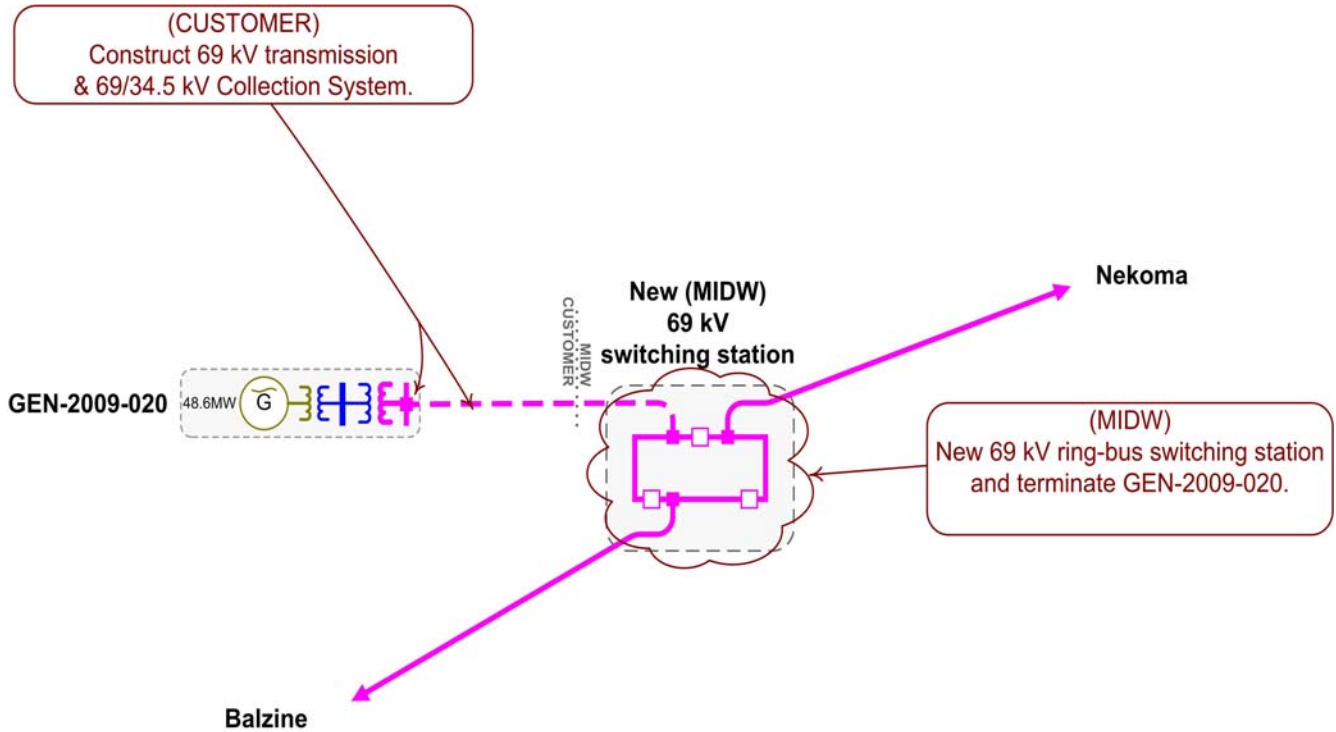

GEN-2009-030

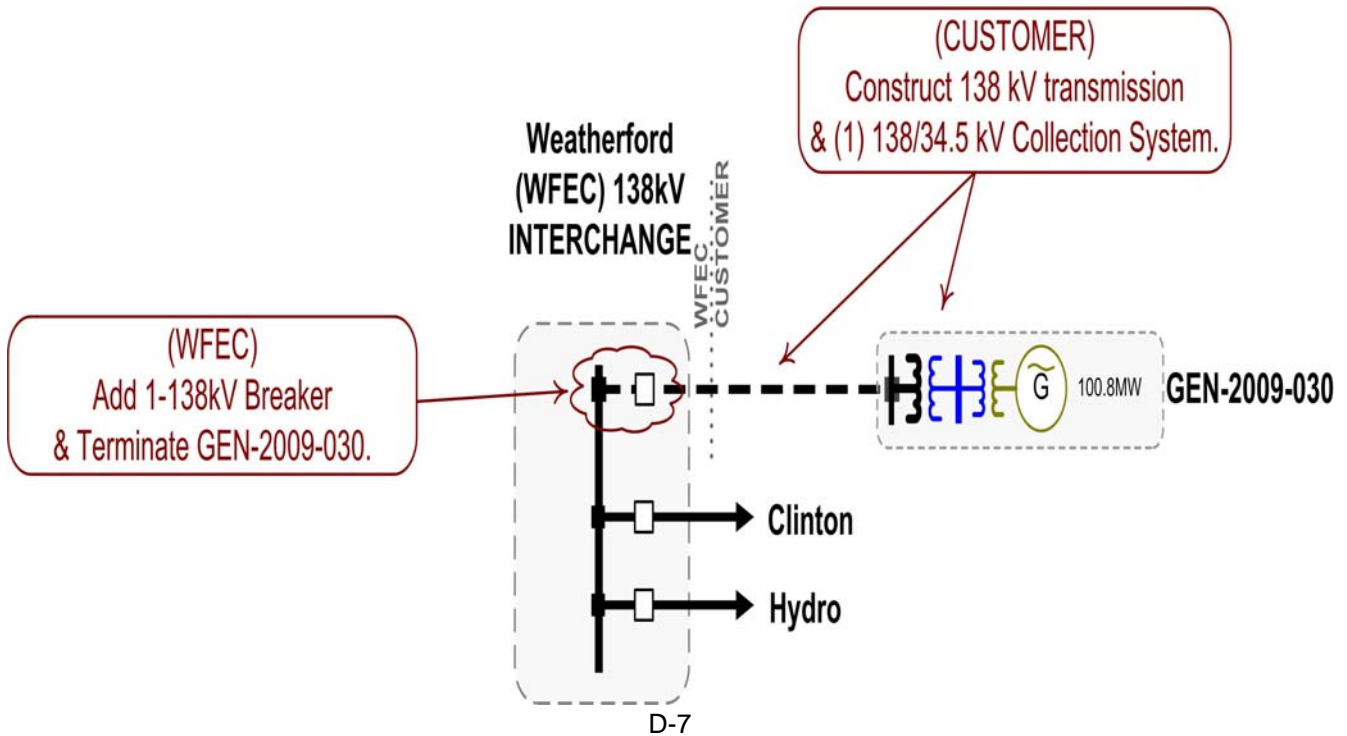

GEN-2009-032S

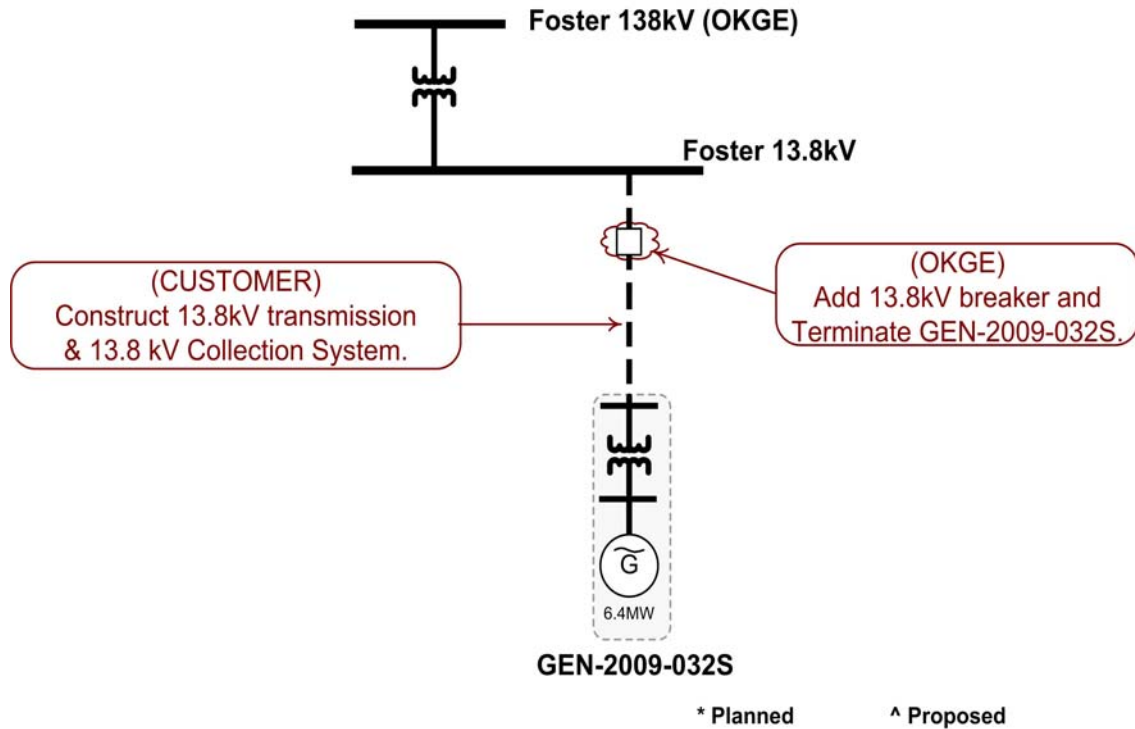

GEN-2009-040

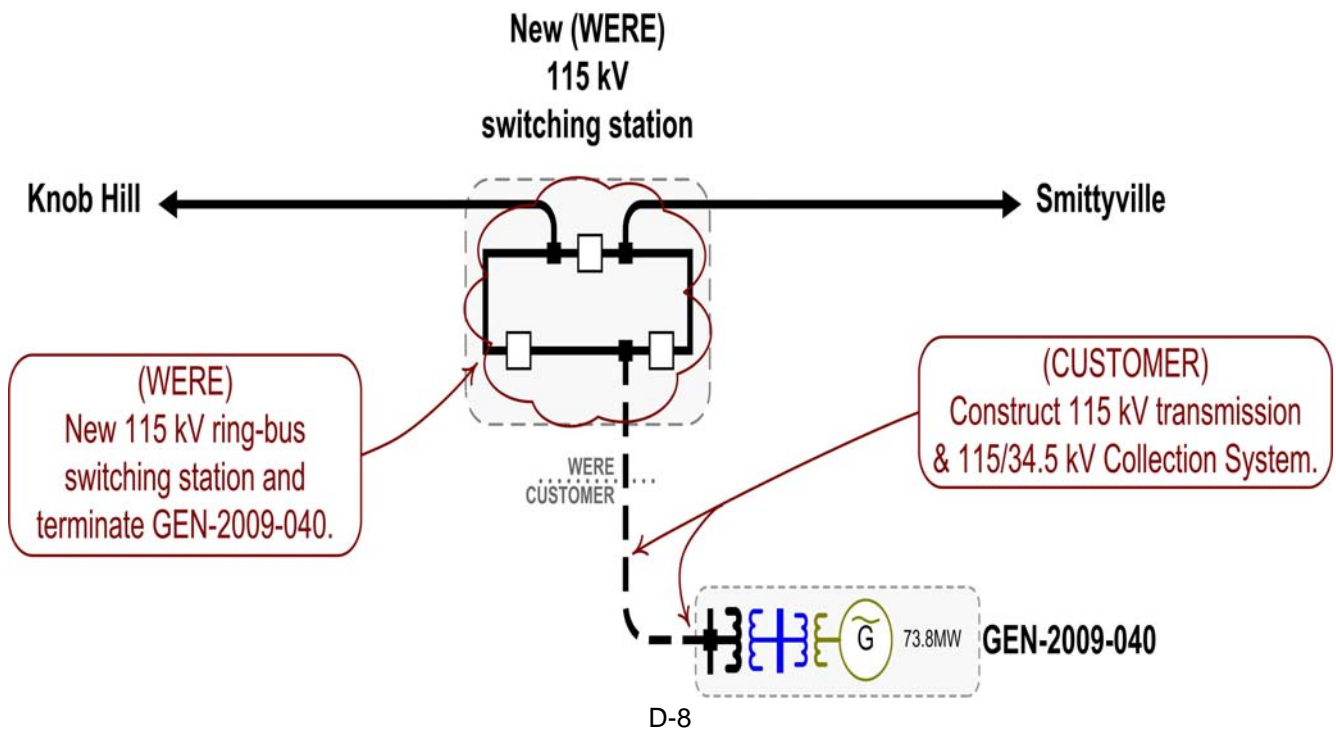

GEN-2009-059

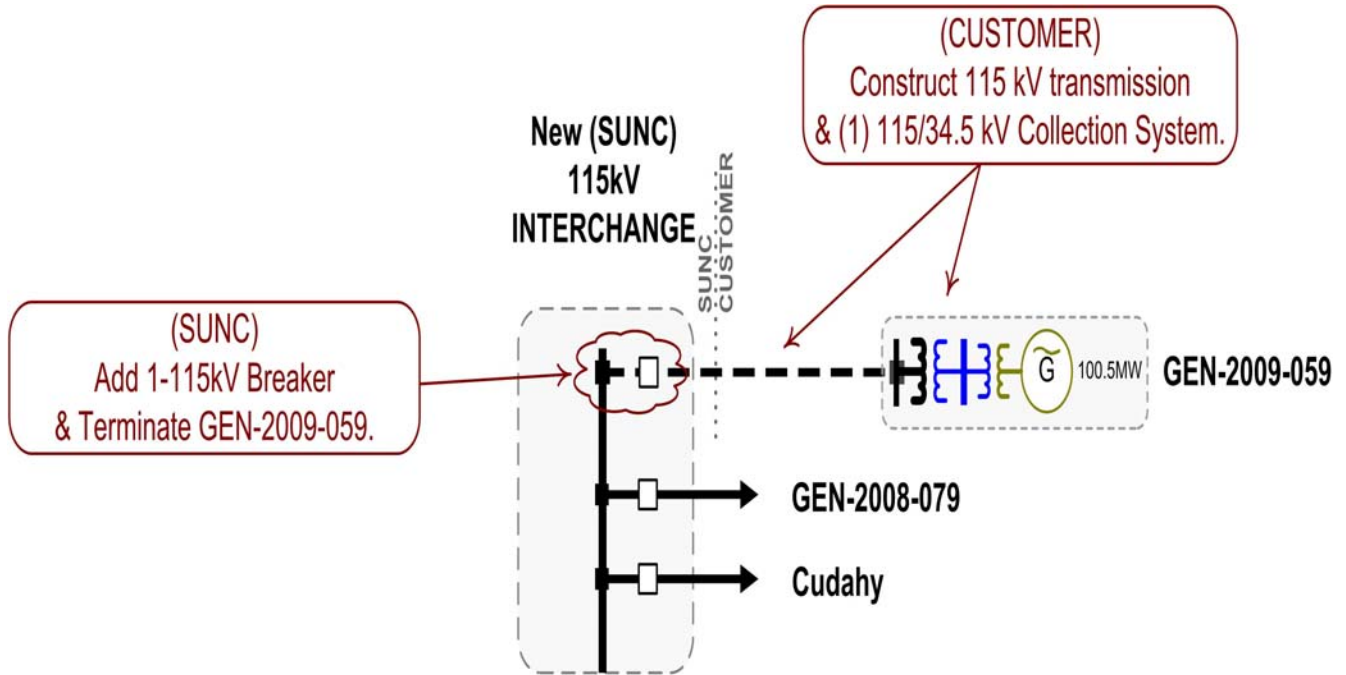

GEN-2009-060

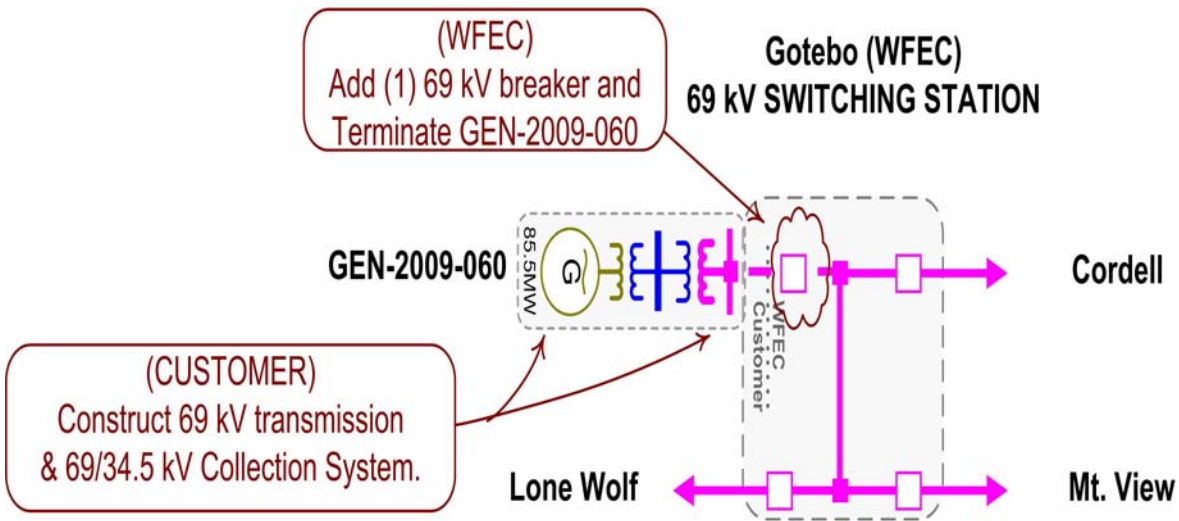

* Planned

^ Proposed

GEN-2009-062

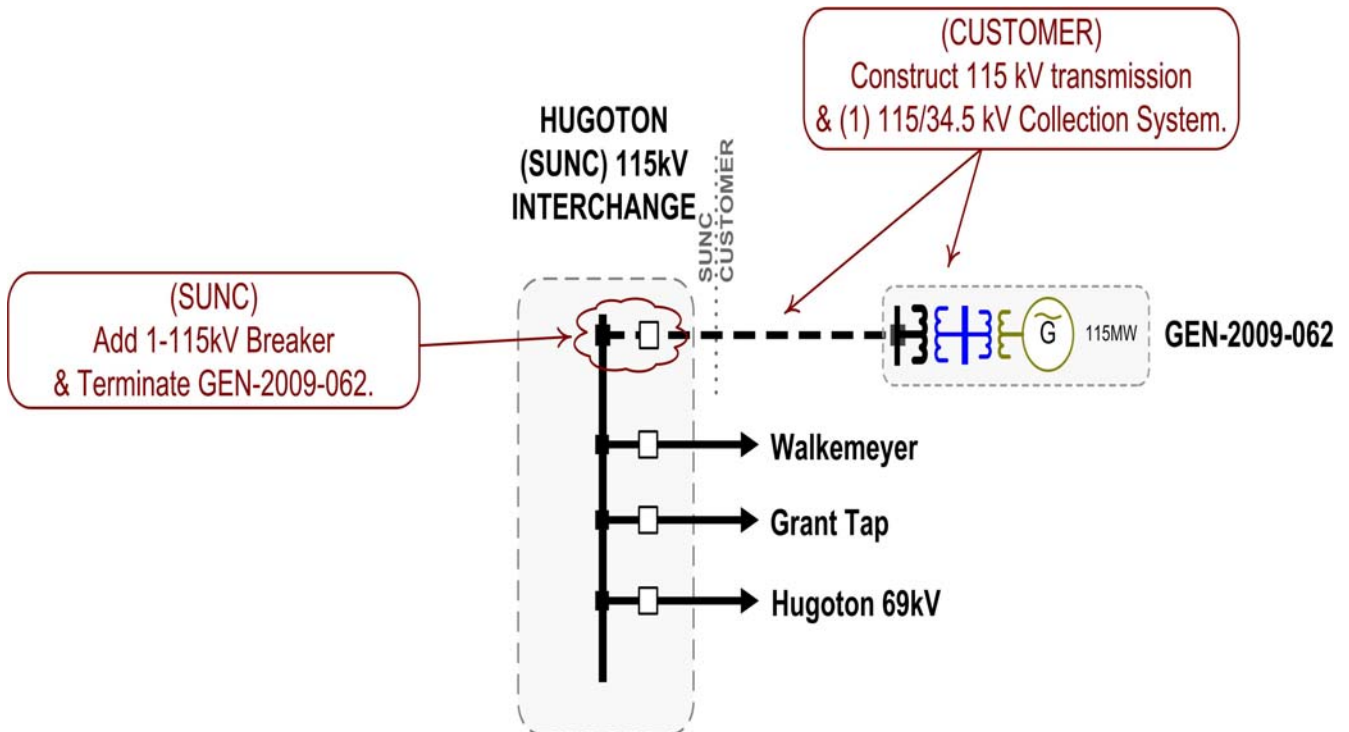

GEN-2009-067S

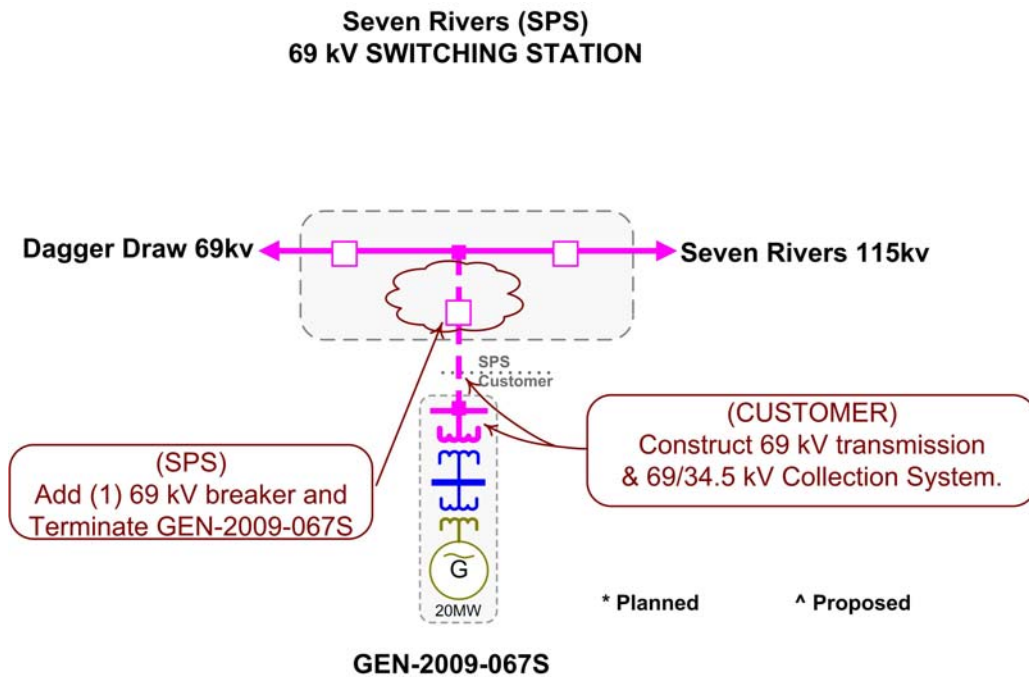

GEN-2010-003

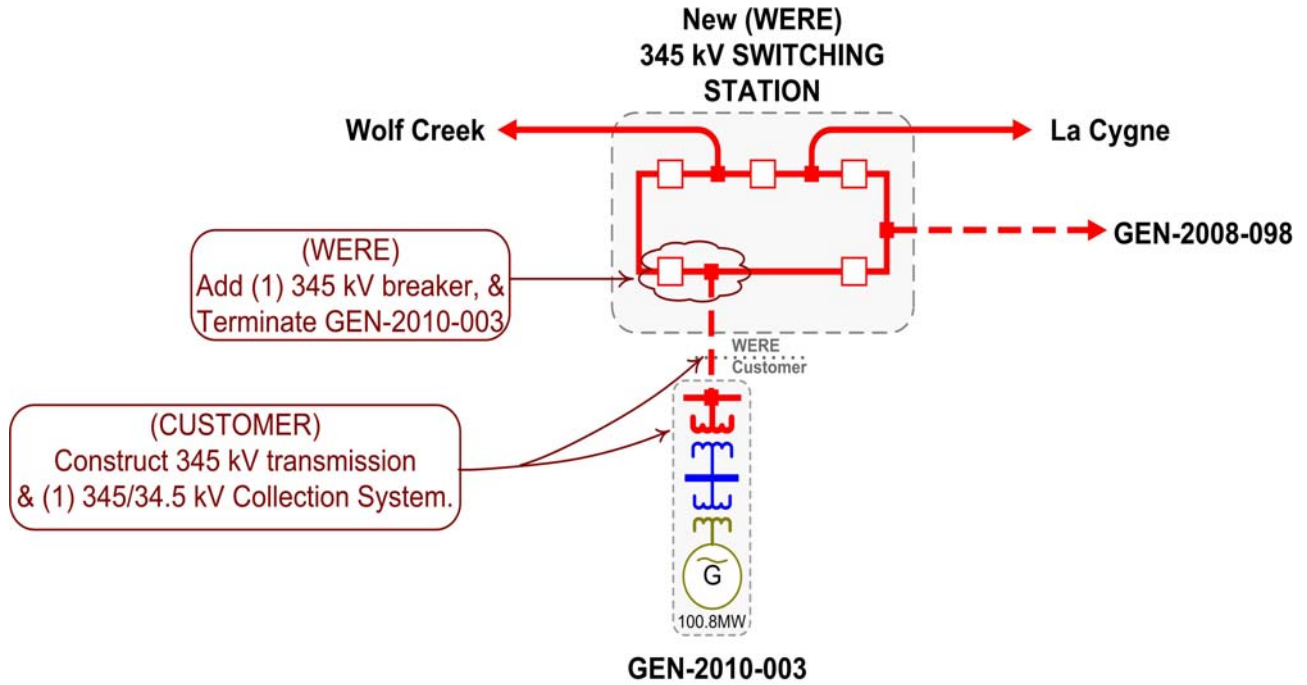

GEN-2010-005

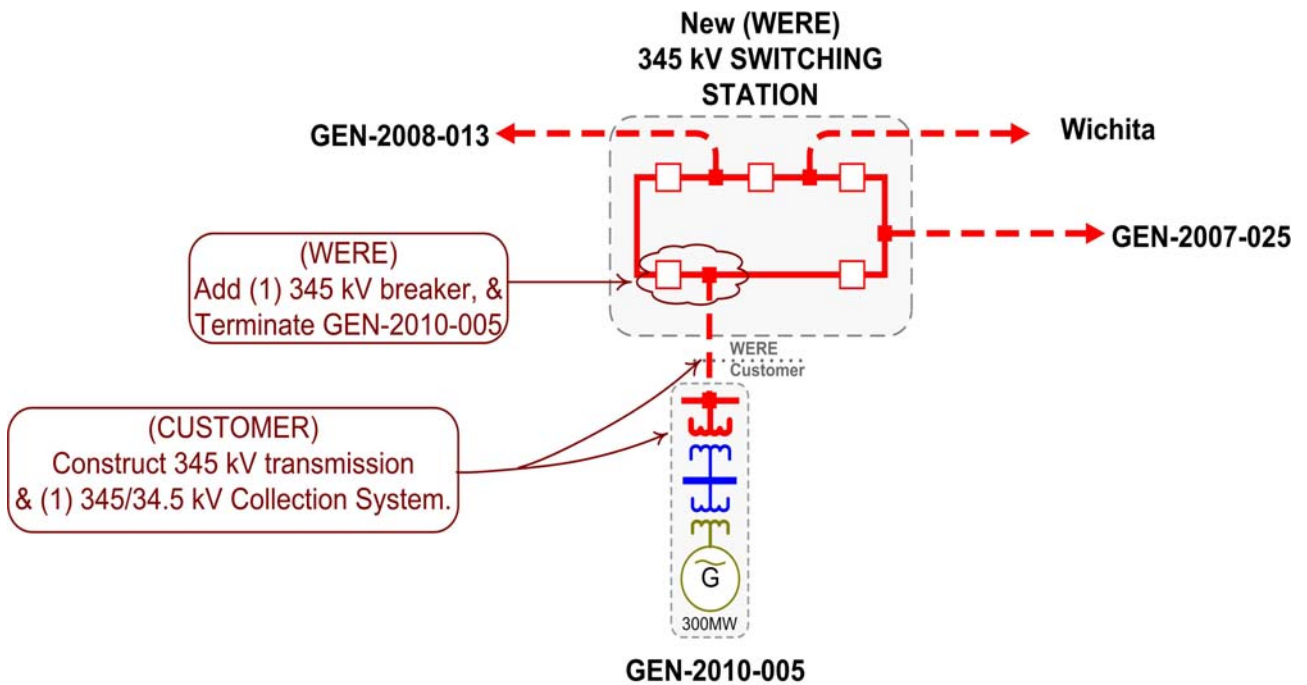

GEN-2010-006

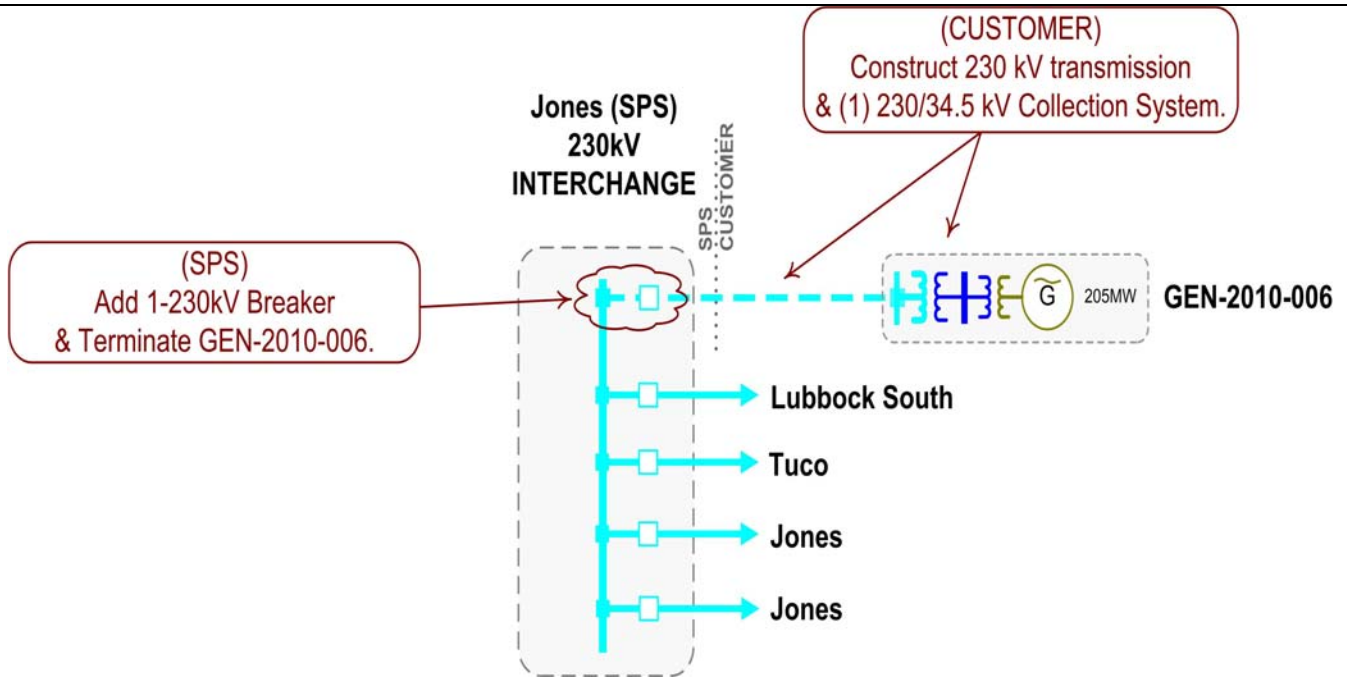

GEN-2010-007

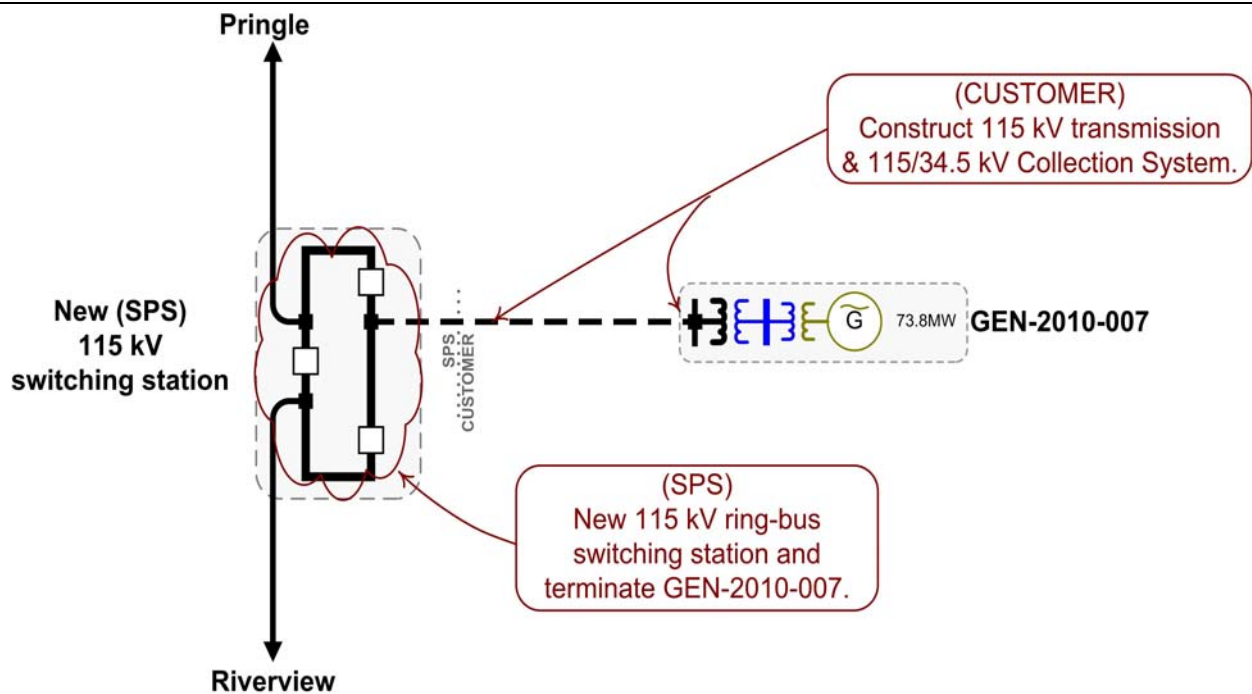

GEN-2010-008

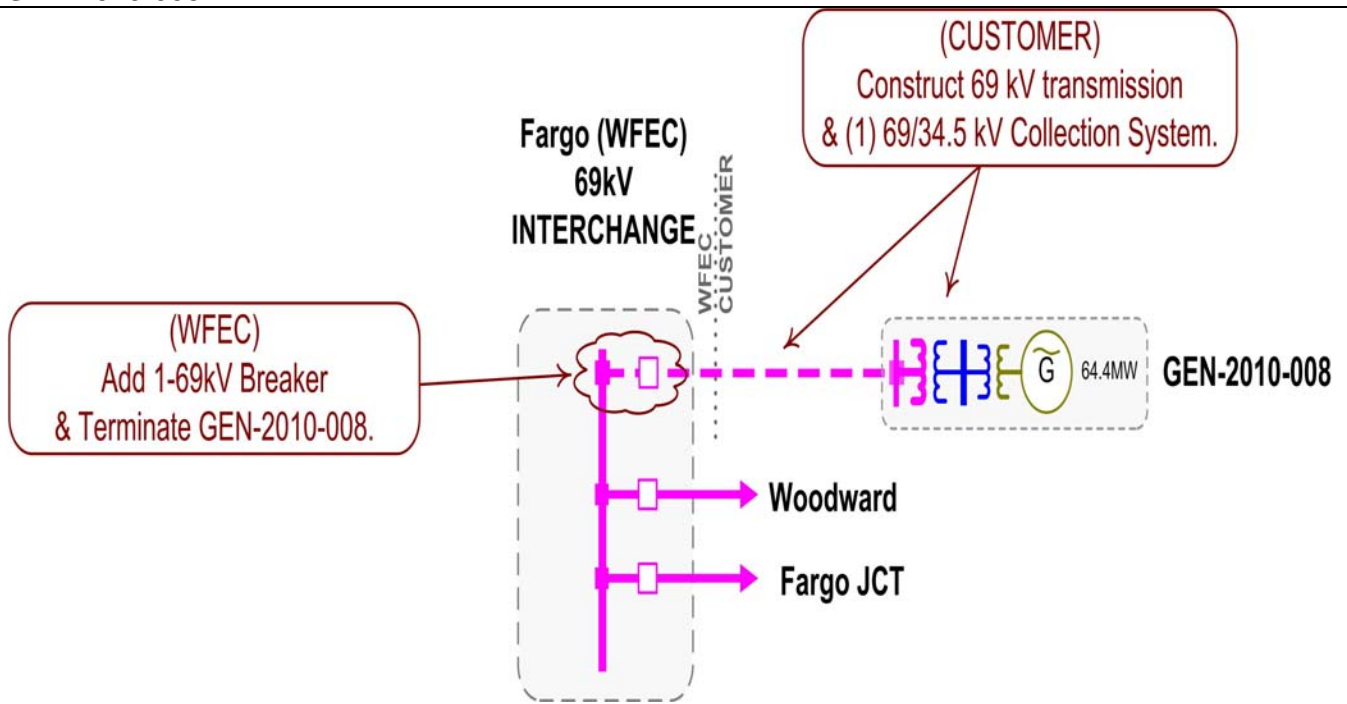

GEN-2010-009

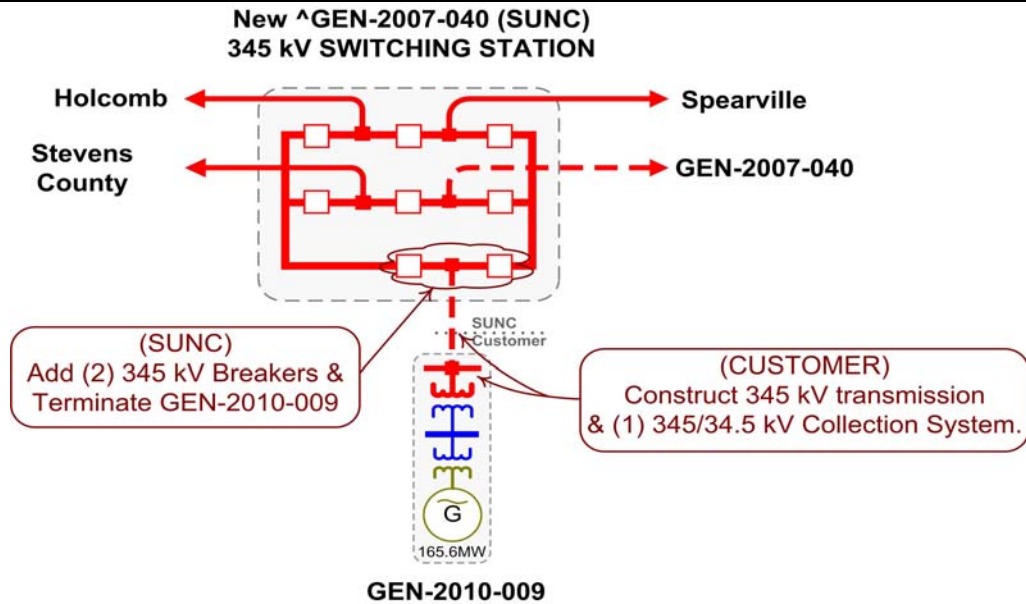

* Planned ^ Proposed

GEN-2010-010

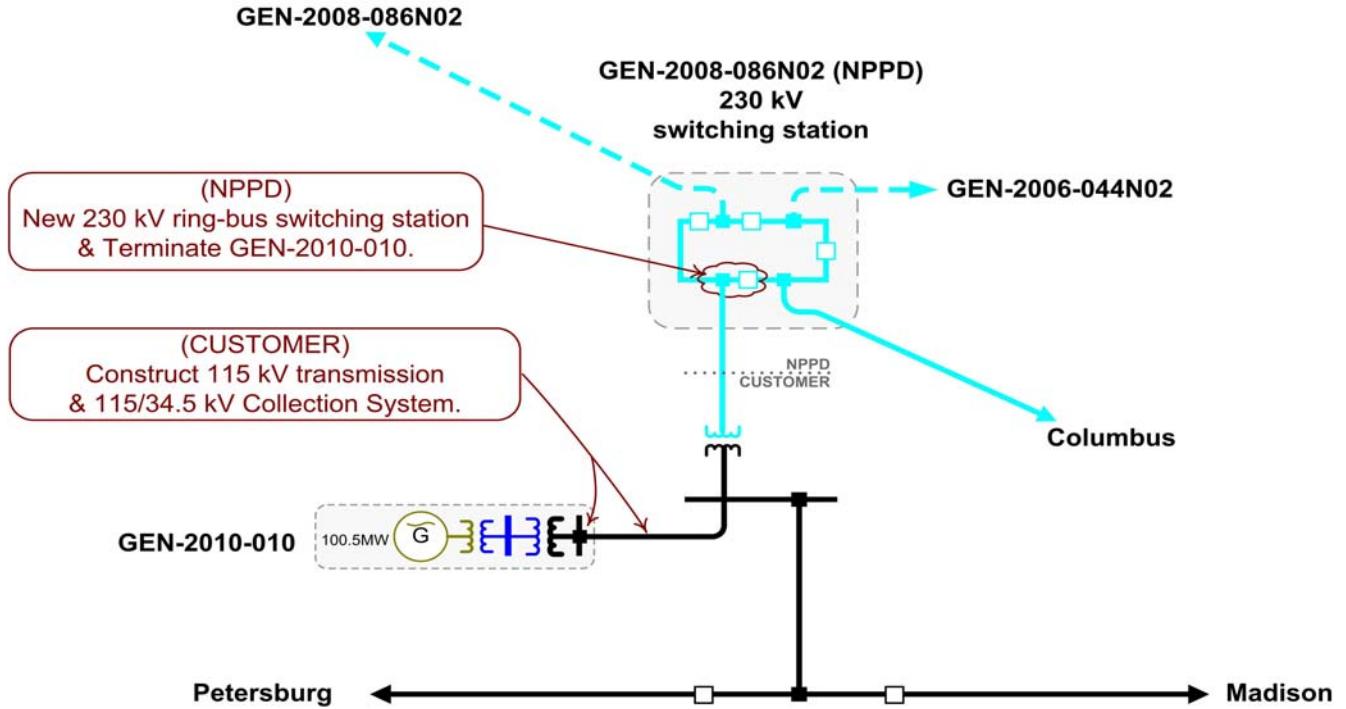

GEN-2010-011

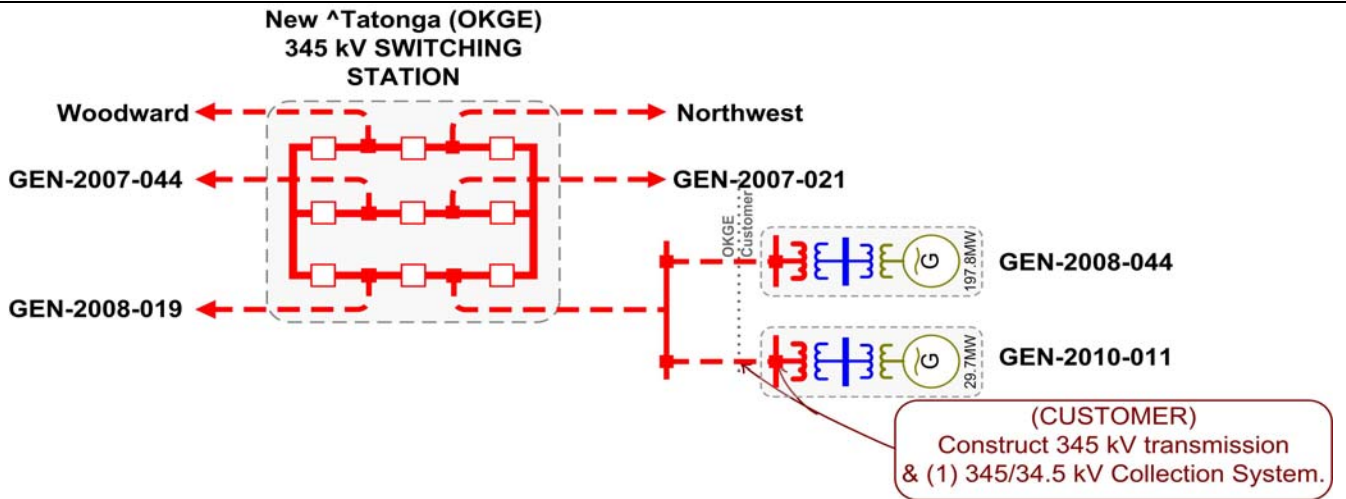

* Planned ^ Proposed

GEN-2010-013

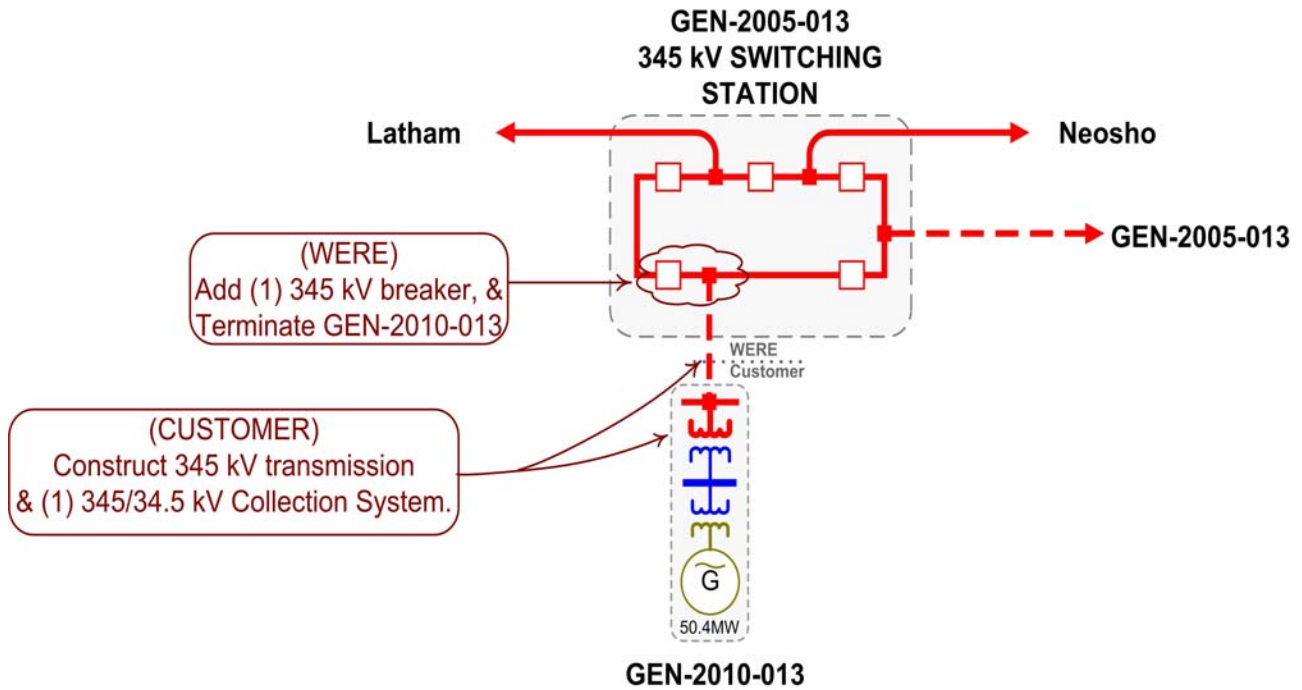

GEN-2010-014

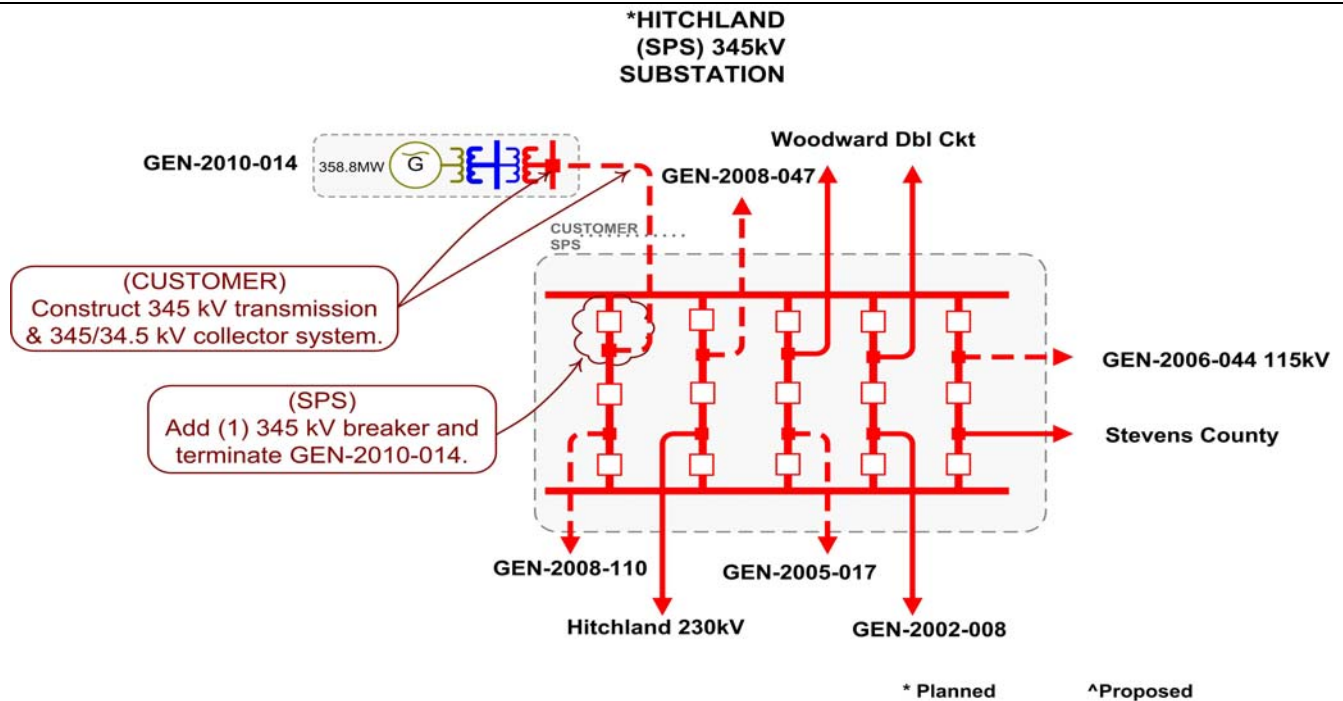

GEN-2010-015

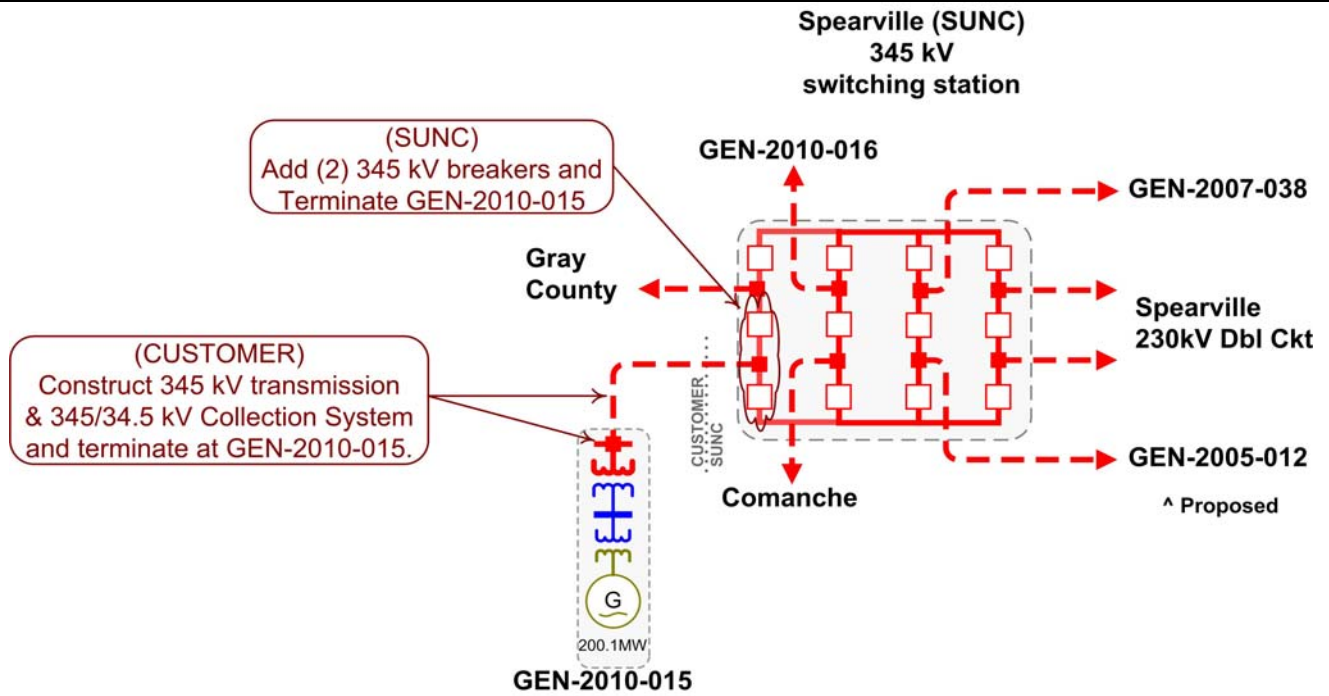

GEN-2010-016

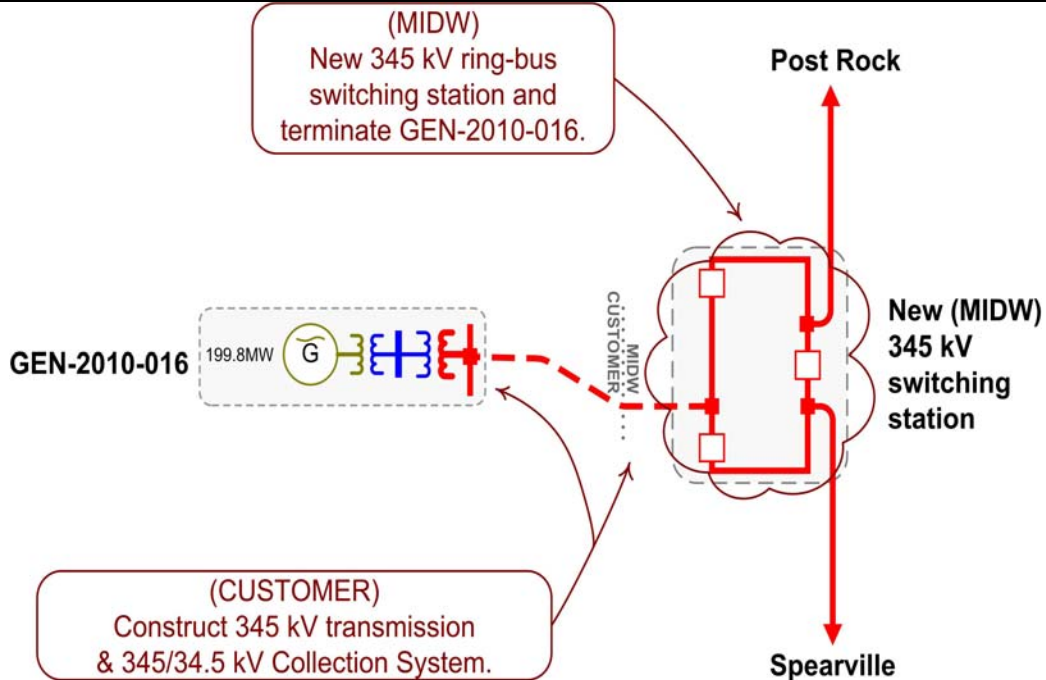

ASGI-2010-010

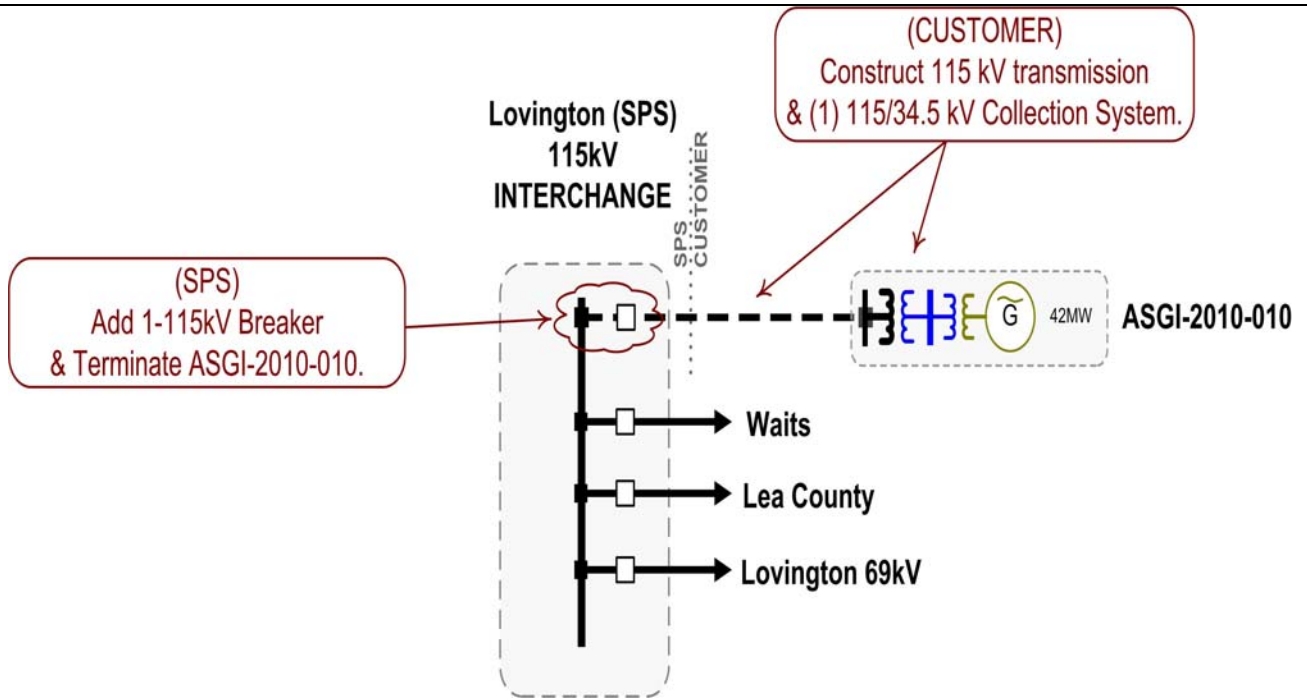

ASGI-2010-011

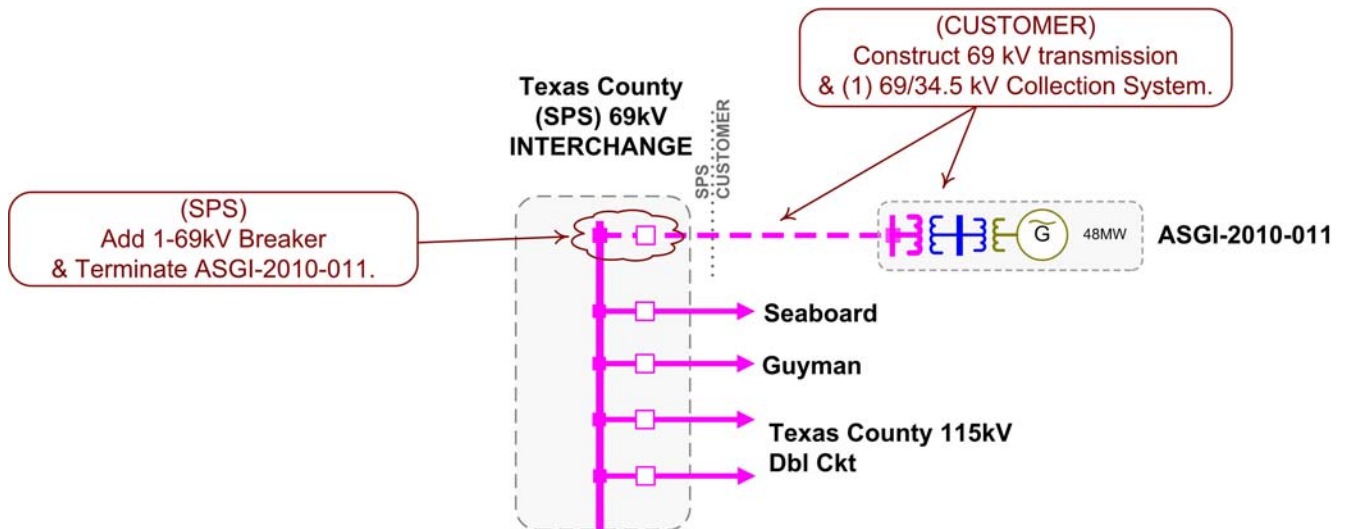

E: Cost Allocation per Interconnection Request

This section shows each Generation Interconnection Request Customer, their current study impacted Network Upgrades, and the previously allocated upgrades upon which they rely to accommodate their interconnection to the transmission system.

The costs associated with the current study Network Upgrades are allocated to the Customers shown in this report.

In addition should a higher queued request, defined as one this study includes as a prior queued request, withdraw, the Network Upgrades assigned to the withdrawn request may be reallocated to the remaining requests that have an impact on the Network Upgrade under a restudy. Also, should a Interconnection Request choose to go into service prior to the operation date of any necessary Network Upgrades, the costs associated with those upgrades may be reallocated to the impacted Interconnection Request. The actual costs allocated to each Generation Interconnection Request Customer will be determined at the time of a restudy.

The required interconnection costs listed do not include all costs associated with the deliverability of the energy to final customers. These costs are determined by separate studies if the Customer submits a Transmission Service Request through SPP's Open Access Same Time Information System (OASIS) as required by Attachment Z1 of the SPP OATT. In addition, costs associated with a short circuit analysis will be allocated should the Interconnection Request Customer choose to execute a Facility Study Agreement.

Appendix E. - Cost Allocation Per Request - DIS-2010-001

(Including Previously Allocated Network Upgrades*)

Interconnection Request and Upgrades	Upgrade Type	Allocated Costs	E + C Costs
ASGI-2010-010			
ASGI-2010-010 Interconnection Costs See Online Diagram.	Previously Allocated	\$1.00	\$1
	Current Study Total	\$1.00	
ASGI-2010-011			
ASGI-2010-011 Interconnection Costs See Online Diagram.	Previously Allocated	\$1.00	\$1
Hitchland 230/115/13.2kV Transformer CKT 2 DISIS-2010-001 Restudy	Current Study	\$2,116,488.34	\$3,000,000
Hitchland - Border 345kV Double CKT Build approximately 105 miles of 345kV.	Current Study	\$6,115,405.62	\$128,120,399
Hitchland - Woodward 345kV CKT 1 Priority Project: Hitchland - Woodward Dbl 345kV CKT (Total Project E&C Cost Shown).	Previously Allocated		\$247,005,793
Border - Woodward 345kV CKT 1 Balanced Portfolio: TUCO - Woodward 345kV CKT (Total Project E&C Cost Shown).	Previously Allocated		\$148,727,500
Medicine Lodge - Woodward 345kV	Previously Allocated		\$194,972,759
Medicine Lodge - Wichita 345kV Priority Project: Spearville - Comanche - Med Lodge - Wichita Dbl 345kV CKT (Total Project E&C Cost Shown).	Previously Allocated		\$356,300,000
	Current Study Total	\$8,231,894.96	
GEN-2006-044N02			
Madison County 230kV Substation See Online Diagram.	Current Study	\$1,800,000.00	\$3,600,000
Madison County Tap 230/115/13.8kV Transformer CKT 1 Install 230/115/13.8kV Transformer and Associated 230kV ring bus and 115kv ring bus at New Madison County Tap.	Current Study	\$9,550,000.00	\$19,100,000
Norfolk - Madison County Tap 115kV CKT 1 Build approximately 20 miles of 115kV between Norfolk and new tap on Petersburg - Madison 115kV CKT 1.	Current Study	\$9,400,000.00	\$18,800,000
	Current Study Total	\$20,750,000.00	
GEN-2008-022			
GEN-2008-022 Interconnection Costs See Online Diagram.	Current Study	\$13,000,000.00	\$13,000,000
Medicine Lodge - Woodward 345kV	Previously Allocated		\$194,972,759
Hitchland - Woodward 345kV CKT 1 Priority Project: Hitchland - Woodward Dbl 345kV CKT (Total Project E&C Cost Shown).	Previously Allocated		\$247,005,793
	Current Study Total	\$13,000,000.00	

* Current Study Requests' Costs of Previously Allocated Network Upgrades will be determined by a restudy, if necessary.

Interconnection Request and Upgrades	Upgrade Type	Allocated Costs	E + C Costs
GEN-2008-037			
GEN-2008-037 Interconnection Costs See Online Diagram.	Current Study	\$1,500,000.00	\$1,500,000
Washita - Gracemont 138kV CKT 2 Build approximately 11 miles of 138kV.	Current Study	\$2,903,533.08	\$5,621,986
Lake Creek - Lone Wolf 69kV CKT 1 Reset CT.	Current Study	\$2,027.60	\$200,000
	Current Study Total	\$4,405,560.68	
GEN-2008-044			
GEN-2008-044 Interconnection Costs See Online Diagram.	Current Study	\$3,403,020.00	\$3,403,020
Medicine Lodge - Woodward 345kV	Previously Allocated		\$194,972,759
Cleveland - Sooner 345kV CKT 1 Balanced Portfolio: Cleveland - Sooner 345kV CKT (Total Project E&C Cost Shown).	Previously Allocated		\$17,000,000
Medicine Lodge - Wichita 345kV Priority Project: Spearville - Comanche - Med Lodge - Wichita Dbl 345kV CKT (Total Project E&C Cost Shown).	Previously Allocated		\$356,300,000
Border - Woodward 345kV CKT 1 Balanced Portfolio: TUCO - Woodward 345kV CKT (Total Project E&C Cost Shown).	Previously Allocated		\$148,727,500
	Current Study Total	\$3,403,020.00	
GEN-2008-046			
GEN-2008-046 Interconnection Costs See Online Diagram.	Current Study	\$3,073,333.00	\$3,073,333
	Current Study Total	\$3,073,333.00	
GEN-2008-047			
GEN-2008-047 Interconnection Costs See Online Diagram.	Current Study	\$10,000,000.00	\$10,000,000
Hitchland - Border 345kV Double CKT Build approximately 105 miles of 345kV.	Current Study	\$15,968,985.49	\$128,120,399
Hitchland - Woodward 345kV CKT 1 Priority Project: Hitchland - Woodward Dbl 345kV CKT (Total Project E&C Cost Shown).	Previously Allocated		\$247,005,793
Medicine Lodge - Woodward 345kV	Previously Allocated		\$194,972,759
Medicine Lodge - Wichita 345kV Priority Project: Spearville - Comanche - Med Lodge - Wichita Dbl 345kV CKT (Total Project E&C Cost Shown).	Previously Allocated		\$356,300,000
	Current Study Total	\$25,968,985.49	
GEN-2008-071			
GEN-2008-071 Interconnection Costs See Online Diagram.	Current Study	\$4,000,000.00	\$4,000,000
	Current Study Total	\$4,000,000.00	

* Current Study Requests' Costs of Previously Allocated Network Upgrades will be determined by a restudy, if necessary.

Interconnection Request and Upgrades	Upgrade Type	Allocated Costs	E + C Costs
GEN-2008-088			
GEN-2008-088 Interconnection Costs See Online Diagram.	Current Study	\$2,884,830.00	\$2,884,830
Switch 2749 - Wildorado 69kV CKT 1 Rebuild approximately 4 miles of 69kV.	Current Study	\$1,461,321.00	\$1,461,321
Hitchland - Border 345kV Double CKT Build approximately 105 miles of 345kV.	Current Study	\$2,716,981.04	\$128,120,399
Hitchland - Woodward 345kV CKT 1 Priority Project: Hitchland - Woodward Dbl 345kV CKT (Total Project E&C Cost Shown).	Previously Allocated		\$247,005,793
Medicine Lodge - Woodward 345kV	Previously Allocated		\$194,972,759
Medicine Lodge - Wichita 345kV Priority Project: Spearville - Comanche - Med Lodge - Wichita Dbl 345kV CKT (Total Project E&C Cost Shown).	Previously Allocated		\$356,300,000
	Current Study Total	\$7,063,132.04	
GEN-2008-098			
GEN-2008-098 Interconnection Costs See Online Diagram.	Current Study	\$8,259,000.00	\$8,259,000
	Current Study Total	\$8,259,000.00	
GEN-2008-110			
GEN-2008-110 Interconnection Costs See Online Diagram.	Current Study	\$2,500,000.00	\$2,500,000
Hitchland - Border 345kV Double CKT Build approximately 105 miles of 345kV.	Current Study	\$44,517,855.24	\$128,120,399
Hitchland - Woodward 345kV CKT 1 Priority Project: Hitchland - Woodward Dbl 345kV CKT (Total Project E&C Cost Shown).	Previously Allocated		\$247,005,793
Border - Woodward 345kV CKT 1 Balanced Portfolio: TUCO - Woodward 345kV CKT (Total Project E&C Cost Shown).	Previously Allocated		\$148,727,500
Medicine Lodge - Woodward 345kV	Previously Allocated		\$194,972,759
Medicine Lodge - Wichita 345kV Priority Project: Spearville - Comanche - Med Lodge - Wichita Dbl 345kV CKT (Total Project E&C Cost Shown).	Previously Allocated		\$356,300,000
	Current Study Total	\$47,017,855.24	
GEN-2008-123N			
GEN-2008-123N Interconnection Costs See Online Diagram. Includes 115kV breakers at Guide Rock.	Current Study	\$6,200,000.00	\$6,200,000
	Current Study Total	\$6,200,000.00	
GEN-2009-008			
GEN-2009-008 Interconnection Costs See Online Diagram.	Current Study	\$1,800,000.00	\$1,800,000
Post Rock 345/230/13.8kV Transformer CKT 2 DISIS-2010-001 Restudy	Current Study	\$4,549,291.69	\$8,000,000

* Current Study Requests' Costs of Previously Allocated Network Upgrades will be determined by a restudy, if necessary.

Interconnection Request and Upgrades	Upgrade Type	Allocated Costs	E + C Costs
South Hays - Hays Plant - Vine Street 115kV CKT 1 Rebuild approximately 4 miles of 115kV.	Current Study	\$3,020,205.00	\$3,200,000
Axtel - Post Rock 345kV CKT 1 Balanced Portfolio: Spearville - Post Rock - Axtel 345kV CKT (Total Project E&C Cost Shown).	Previously Allocated		\$112,700,000
Comanche - Medicine Lodge 345kV CKT 1 Priority Project: Spearville - Comanche - Med Lodge - Wichita Dbl 345kV CKT (Total Project E&C Cost Shown).	Previously Allocated		\$356,300,000
Spearville - Comanche 345kV CKT 1 Priority Project: Spearville - Comanche - Med Lodge - Wichita Dbl 345kV CKT (Total Project E&C Cost Shown).	Previously Allocated		\$356,300,000
Spearville - Comanche 345kV CKT 2 Priority Project: Spearville - Comanche - Med Lodge - Wichita Dbl 345kV CKT (Total Project E&C Cost Shown).	Previously Allocated		\$356,300,000
Medicine Lodge - Wichita 345kV Priority Project: Spearville - Comanche - Med Lodge - Wichita Dbl 345kV CKT (Total Project E&C Cost Shown).	Previously Allocated		\$356,300,000
	Current Study Total	\$9,369,496.69	
GEN-2009-020			
GEN-2009-020 Interconnection Costs See Online Diagram.	Current Study	\$1,800,000.00	\$1,800,000
Post Rock 345/230/13.8kV Transformer CKT 2 DISIS-2010-001 Restudy	Current Study	\$323,940.30	\$8,000,000
South Hays - Hays Plant - Vine Street 115kV CKT 1 Rebuild approximately 4 miles of 115kV.	Current Study	\$179,795.00	\$3,200,000
Axtel - Post Rock 345kV CKT 1 Balanced Portfolio: Spearville - Post Rock - Axtel 345kV CKT (Total Project E&C Cost Shown).	Previously Allocated		\$112,700,000
Spearville - Comanche 345kV CKT 2 Priority Project: Spearville - Comanche - Med Lodge - Wichita Dbl 345kV CKT (Total Project E&C Cost Shown).	Previously Allocated		\$356,300,000
Spearville - Comanche 345kV CKT 1 Priority Project: Spearville - Comanche - Med Lodge - Wichita Dbl 345kV CKT (Total Project E&C Cost Shown).	Previously Allocated		\$356,300,000
Comanche - Medicine Lodge 345kV CKT 1 Priority Project: Spearville - Comanche - Med Lodge - Wichita Dbl 345kV CKT (Total Project E&C Cost Shown).	Previously Allocated		\$356,300,000
Medicine Lodge - Wichita 345kV Priority Project: Spearville - Comanche - Med Lodge - Wichita Dbl 345kV CKT (Total Project E&C Cost Shown).	Previously Allocated		\$356,300,000
	Current Study Total	\$2,303,735.30	
GEN-2009-030			
GEN-2009-030 Interconnection Costs See Online Diagram.	Current Study	\$2,000,000.00	\$2,000,000
Washita - Weatherford 138kV CKT 1 Build approximately 50 miles of 138kV.	Current Study	\$22,435,002.31	\$22,500,000
Washita - Gracemont 138kV CKT 2 Build approximately 11 miles of 138kV.	Current Study	\$2,007,857.24	\$5,621,986
	Current Study Total	\$26,442,859.55	

* Current Study Requests' Costs of Previously Allocated Network Upgrades will be determined by a restudy, if necessary.

Interconnection Request and Upgrades	Upgrade Type	Allocated Costs	E + C Costs
GEN-2009-032S			
GEN-2009-032S Interconnection Costs	Current Study	\$238,259.00	\$238,259
	Current Study Total	\$238,259.00	
GEN-2009-040			
GEN-2009-040 Interconnection Costs See Online Diagram.	Current Study	\$5,240,000.00	\$5,240,000
	Current Study Total	\$5,240,000.00	
GEN-2009-059			
GEN-2009-059 Interconnection Costs See Online Diagram.	Current Study	\$3,800,000.00	\$3,800,000
Spearville 345/115/13.8kV Transformer CKT 1 New 345/115kV Spearville Transformer	Current & Previous Allocation	\$7,320,757.00	\$10,000,000
GEN-2008-079 Tap - Spearville 115KV CKT 1 Construct approximately 40 miles of new 115kV.	Current Study	\$11,522,174.39	\$16,000,000
Cimarron River Plant - Cimarron River Tap 115kV CKT 1 Rebuild approximately 4 miles of 115kV.	Current Study	\$1,677,185.93	\$2,000,000
Post Rock 345/230/13.8kV Transformer CKT 2 DISIS-2010-001 Restudy	Current Study	\$223,881.00	\$8,000,000
Judson Large - North Judson Large 115KV CKT 2 Construct approximately 1 mile of new 115kV for 2nd circuit	Previously Allocated		\$400,000
North Judson Large - Spearville 115KV CKT 2 DIS-2009-001-1 upgrade.	Previously Allocated		\$6,000,000
Spearville - Comanche 345kV CKT 2 Priority Project: Spearville - Comanche - Med Lodge - Wichita Dbl 345kV CKT (Total Project E&C Cost Shown.	Previously Allocated		\$356,300,000
Spearville - Comanche 345kV CKT 1 Priority Project: Spearville - Comanche - Med Lodge - Wichita Dbl 345kV CKT (Total Project E&C Cost Shown.	Previously Allocated		\$356,300,000
Comanche - Medicine Lodge 345kV CKT 2 Priority Project: Spearville - Comanche - Med Lodge - Wichita Dbl 345kV CKT (Total Project E&C Cost Shown.	Previously Allocated		\$356,300,000
Comanche - Medicine Lodge 345kV CKT 1 Priority Project: Spearville - Comanche - Med Lodge - Wichita Dbl 345kV CKT (Total Project E&C Cost Shown.	Previously Allocated		\$356,300,000
Spearville - Axtel 345kV CKT 1(North of GEN-2010-016 Tap) Balanced Portfolio: Spearville - Post Rock - Axtel 345kV CKT (Total Project E&C Cost Shown).	Previously Allocated		\$112,700,000
Medicine Lodge - Wichita 345kV Priority Project: Spearville - Comanche - Med Lodge - Wichita Dbl 345kV CKT (Total Project E&C Cost Shown).	Previously Allocated		\$356,300,000
Axtel - Post Rock 345kV CKT 1 Balanced Portfolio: Spearville - Post Rock - Axtel 345kV CKT (Total Project E&C Cost Shown).	Previously Allocated		\$112,700,000
	Current Study Total	\$24,543,998.32	
GEN-2009-060			
GEN-2009-060 Interconnection Costs See Online Diagram.	Current Study	\$1,000,000.00	\$1,000,000

* Current Study Requests' Costs of Previously Allocated Network Upgrades will be determined by a restudy, if necessary.

Interconnection Request and Upgrades	Upgrade Type	Allocated Costs	E + C Costs
Lake Creek - Lone Wolf 69kV CKT 1 Reset CT.	Current Study	\$197,972.40	\$200,000
Washita - Gracemont 138kV CKT 2 Build approximately 11 miles of 138kV.	Current Study	\$710,595.67	\$5,621,986
Washita - Weatherford 138kV CKT 1 Build approximately 50 miles of 138kV.	Current Study	\$64,997.69	\$22,500,000
	Current Study Total	\$1,973,565.76	
GEN-2009-062			
GEN-2009-062 Interconnection Costs See Online Diagram.	Current Study	\$1,800,000.00	\$1,800,000
Spearville 345/115/13.8kV Transformer CKT 1 New 345/115kV Spearville Transformer	Current & Previous Allocation	\$2,679,243.00	\$10,000,000
GEN-2008-079 Tap - Spearville 115KV CKT 1 Construct approximately 40 miles of new 115kV.	Current Study	\$4,477,825.61	\$16,000,000
Post Rock 345/230/13.8kV Transformer CKT 2 DISIS-2010-001 Restudy	Current Study	\$183,127.29	\$8,000,000
Spearville - Comanche 345kV CKT 2 Priority Project: Spearville - Comanche - Med Lodge - Wichita Dbl 345kV CKT (Total Project E&C Cost Shown).	Previously Allocated		\$356,300,000
Spearville - Comanche 345kV CKT 1 Priority Project: Spearville - Comanche - Med Lodge - Wichita Dbl 345kV CKT (Total Project E&C Cost Shown).	Previously Allocated		\$356,300,000
Comanche - Medicine Lodge 345kV CKT 2 Priority Project: Spearville - Comanche - Med Lodge - Wichita Dbl 345kV CKT (Total Project E&C Cost Shown).	Previously Allocated		\$356,300,000
Comanche - Medicine Lodge 345kV CKT 1 Priority Project: Spearville - Comanche - Med Lodge - Wichita Dbl 345kV CKT (Total Project E&C Cost Shown).	Previously Allocated		\$356,300,000
Medicine Lodge - Wichita 345kV Priority Project: Spearville - Comanche - Med Lodge - Wichita Dbl 345kV CKT (Total Project E&C Cost Shown).	Previously Allocated		\$356,300,000
Spearville - Axtel 345kV CKT 1(North of GEN-2010-016 Tap) Balanced Portfolio: Spearville - Post Rock - Axtel 345kV CKT (Total Project E&C Cost Shown).	Previously Allocated		\$112,700,000
Judson Large - North Judson Large 115KV CKT 2 Construct approximately 1 mile of new 115kV for 2nd circuit	Previously Allocated		\$400,000
Axtel - Post Rock 345kV CKT 1 Balanced Portfolio: Spearville - Post Rock - Axtel 345kV CKT (Total Project E&C Cost Shown).	Previously Allocated		\$112,700,000
North Judson Large - Spearville 115KV CKT 2 DIS-2009-001-1 upgrade.	Previously Allocated		\$6,000,000
	Current Study Total	\$9,140,195.90	
GEN-2009-067S			
GEN-2009-067S Interconnection Costs See Online Diagram.	Current Study	\$1,306,757.00	\$1,306,757
Medicine Lodge - Woodward 345kV	Previously Allocated		\$194,972,759

* Current Study Requests' Costs of Previously Allocated Network Upgrades will be determined by a restudy, if necessary.

Interconnection Request and Upgrades	Upgrade Type	Allocated Costs	E + C Costs
Hitchland - Woodward 345kV CKT 1 Priority Project: Hitchland - Woodward Dbl 345kV CKT (Total Project E&C Cost Shown).	Previously Allocated		\$247,005,793
	Current Study Total	\$1,306,757.00	
GEN-2010-003			
GEN-2010-003 Interconnection Costs See Oonline Diagram.	Current Study	\$26,000.00	\$26,000
	Current Study Total	\$26,000.00	
GEN-2010-005			
GEN-2010-005 Interconnection Costs See Oonline Diagram.	Current Study	\$26,000.00	\$26,000
	Current Study Total	\$26,000.00	
GEN-2010-006			
GEN-2010-006 Interconnection Costs See Oonline Diagram.	Current Study	\$1,408,514.00	\$1,408,514
	Current Study Total	\$1,408,514.00	
GEN-2010-007			
GEN-2010-007 Interconnection Costs See Oonline Diagram.	Current Study	\$2,867,363.00	\$2,867,363
Hitchland 230/115/13.2kV Transformer CKT 2 DISIS-2010-001 Restudy	Current Study	\$883,511.66	\$3,000,000
Hitchland - Border 345kV Double CKT Build approximately 105 miles of 345kV.	Current Study	\$5,528,138.15	\$128,120,399
Border - Woodward 345KV CKT 1 Balanced Portfolio: TUCO - Woodward 345kV CKT (Total Project E&C Cost Shown).	Previously Allocated		\$148,727,500
Hitchland - Woodward 345kV CKT 1 Priority Project: Hitchland - Woodward Dbl 345kV CKT (Total Project E&C Cost Shown).	Previously Allocated		\$247,005,793
Medicine Lodge - Woodward 345kV	Previously Allocated		\$194,972,759
Swisher - Amarillo South 230kV CKT 1 (South of GEN-2007-048 Tap) ICS-2008-001-2 upgrade.	Previously Allocated		\$77,464
Medicine Lodge - Wichita 345kV Priority Project: Spearville - Comanche - Med Lodge - Wichita Dbl 345kV CKT (Total Project E&C Cost Shown).	Previously Allocated		\$356,300,000
	Current Study Total	\$9,279,012.81	
GEN-2010-008			
GEN-2010-008 Interconnection Costs See Oonline Diagram.	Current Study	\$750,000.00	\$750,000
Fargo Junction - Woodward 69kV CKT 1 Rebuild approximately 2 miles of 69kV.	Current Study	\$750,000.00	\$750,000
Medicine Lodge - Woodward 345kV	Previously Allocated		\$194,972,759
Medicine Lodge - Wichita 345kV Priority Project: Spearville - Comanche - Med Lodge - Wichita Dbl 345kV CKT (Total Project E&C Cost Shown).	Previously Allocated		\$356,300,000

* Current Study Requests' Costs of Previously Allocated Network Upgrades will be determined by a restudy, if necessary.

Interconnection Request and Upgrades	Upgrade Type	Allocated Costs	E + C Costs
Border - Woodward 345kV CKT 1 Balanced Portfolio: TUCO - Woodward 345kV CKT (Total Project E&C Cost Shown).	Previously Allocated		\$148,727,500
	Current Study Total	\$1,500,000.00	
GEN-2010-009			
GEN-2010-009 Interconnection Costs See Online Diagram.	Current Study	\$7,500,000.00	\$7,500,000
Post Rock 345/230/13.8kV Transformer CKT 2 DISIS-2010-001 Restudy	Current Study	\$388,511.21	\$8,000,000
Spearville - Comanche 345kV CKT 1 Priority Project: Spearville - Comanche - Med Lodge - Wichita Dbl 345kV CKT (Total Project E&C Cost Shown).	Previously Allocated		\$356,300,000
Spearville - Comanche 345kV CKT 2 Priority Project: Spearville - Comanche - Med Lodge - Wichita Dbl 345kV CKT (Total Project E&C Cost Shown).	Previously Allocated		\$356,300,000
Comanche - Medicine Lodge 345kV CKT 2 Priority Project: Spearville - Comanche - Med Lodge - Wichita Dbl 345kV CKT (Total Project E&C Cost Shown).	Previously Allocated		\$356,300,000
Comanche - Medicine Lodge 345kV CKT 1 Priority Project: Spearville - Comanche - Med Lodge - Wichita Dbl 345kV CKT (Total Project E&C Cost Shown).	Previously Allocated		\$356,300,000
Spearville - Axtel 345kV CKT 1(North of GEN-2010-016 Tap) Balanced Portfolio: Spearville - Post Rock - Axtel 345kV CKT (Total Project E&C Cost Shown).	Previously Allocated		\$112,700,000
Medicine Lodge - Wichita 345kV Priority Project: Spearville - Comanche - Med Lodge - Wichita Dbl 345kV CKT (Total Project E&C Cost Shown).	Previously Allocated		\$356,300,000
Axtel - Post Rock 345kV CKT 1 Balanced Portfolio: Spearville - Post Rock - Axtel 345kV CKT (Total Project E&C Cost Shown).	Previously Allocated		\$112,700,000
	Current Study Total	\$7,888,511.21	
GEN-2010-010			
Madison County 230kV Substation See Online Diagram.	Current Study	\$1,800,000.00	\$3,600,000
Madison County Tap 230/115/13.8kV Transformer CKT 1 Install 230/115/13.8kV Transformer and Associated 230kV ring bus and 115kv ring bus at New Madison County Tap.	Current Study	\$9,550,000.00	\$19,100,000
Norfolk - Madison County Tap 115kV CKT 1 Build approximately 20 miles of 115kV between Norfolk and new tap on Petersburg - Madison 115kV CKT 1.	Current Study	\$9,400,000.00	\$18,800,000
	Current Study Total	\$20,750,000.00	
GEN-2010-011			
GEN-2010-011 Interconnection Costs See Online Diagram.	Current Study	\$1.00	\$1
Medicine Lodge - Woodward 345kV	Previously Allocated		\$194,972,759
Medicine Lodge - Wichita 345kV Priority Project: Spearville - Comanche - Med Lodge - Wichita Dbl 345kV CKT (Total Project E&C Cost Shown).	Previously Allocated		\$356,300,000

* Current Study Requests' Costs of Previously Allocated Network Upgrades will be determined by a restudy, if necessary.

Interconnection Request and Upgrades	Upgrade Type	Allocated Costs	E + C Costs
Border - Woodward 345KV CKT 1 Balanced Portfolio: TUCO - Woodward 345kV CKT (Total Project E&C Cost Shown).	Previously Allocated		\$148,727,500
	Current Study Total	\$1.00	
GEN-2010-013			
GEN-2010-013 Interconnection Costs See Online Diagram.	Current Study	\$1,692,000.00	\$1,692,000
	Current Study Total	\$1,692,000.00	
GEN-2010-014			
GEN-2010-014 Interconnection Costs See Online Diagram.	Current Study	\$2,500,000.00	\$2,500,000
Hitchland - Border 345kV Double CKT Build approximately 105 miles of 345kV.	Current Study	\$53,273,033.44	\$128,120,399
Hitchland - Woodward 345kV CKT 1 Priority Project: Hitchland - Woodward Dbl 345kV CKT (Total Project E&C Cost Shown).	Previously Allocated		\$247,005,793
Border - Woodward 345KV CKT 1 Balanced Portfolio: TUCO - Woodward 345kV CKT (Total Project E&C Cost Shown).	Previously Allocated		\$148,727,500
Medicine Lodge - Woodward 345kV	Previously Allocated		\$194,972,759
Medicine Lodge - Wichita 345kV Priority Project: Spearville - Comanche - Med Lodge - Wichita Dbl 345kV CKT (Total Project E&C Cost Shown).	Previously Allocated		\$356,300,000
	Current Study Total	\$55,773,033.44	
GEN-2010-015			
GEN-2010-015 Interconnection Costs See Online Diagram.	Current Study	\$7,500,000.00	\$7,500,000
Post Rock 345/230/13.8kV Transformer CKT 2 DISIS-2010-001 Restudy	Current Study	\$607,271.02	\$8,000,000
Cimarron River Plant - Cimarron River Tap 115kV CKT 1 Rebuild approximately 4 miles of 115kV.	Current Study	\$188,126.05	\$2,000,000
Spearville - Comanche 345kV CKT 1 Priority Project: Spearville - Comanche - Med Lodge - Wichita Dbl 345kV CKT (Total Project E&C Cost Shown).	Previously Allocated		\$356,300,000
Spearville - Comanche 345kV CKT 2 Priority Project: Spearville - Comanche - Med Lodge - Wichita Dbl 345kV CKT (Total Project E&C Cost Shown).	Previously Allocated		\$356,300,000
Comanche - Medicine Lodge 345kV CKT 2 Priority Project: Spearville - Comanche - Med Lodge - Wichita Dbl 345kV CKT (Total Project E&C Cost Shown).	Previously Allocated		\$356,300,000
Comanche - Medicine Lodge 345kV CKT 1 Priority Project: Spearville - Comanche - Med Lodge - Wichita Dbl 345kV CKT (Total Project E&C Cost Shown).	Previously Allocated		\$356,300,000
Spearville - Axtel 345kV CKT 1(North of GEN-2010-016 Tap) Balanced Portfolio: Spearville - Post Rock - Axtel 345kV CKT (Total Project E&C Cost Shown).	Previously Allocated		\$112,700,000
Medicine Lodge - Wichita 345kV Priority Project: Spearville - Comanche - Med Lodge - Wichita Dbl 345kV CKT (Total Project E&C Cost Shown).	Previously Allocated		\$356,300,000

* Current Study Requests' Costs of Previously Allocated Network Upgrades will be determined by a restudy, if necessary.

Interconnection Request and Upgrades	Upgrade Type	Allocated Costs	E + C Costs
Axtel - Post Rock 345kV CKT 1 Balanced Portfolio: Spearville - Post Rock - Axtel 345kV CKT (Total Project E&C Cost Shown).	Previously Allocated		\$112,700,000
	Current Study Total	\$8,295,397.07	
GEN-2010-016			
GEN-2010-016 Interconnection Costs See Online Diagram.	Current Study	\$10,000,000.00	\$10,000,000
Post Rock 345/230/13.8kV Transformer CKT 2 DISIS-2010-001 Restudy	Current Study	\$1,723,977.48	\$8,000,000
Cimarron River Plant - Cimarron River Tap 115kV CKT 1 Rebuild approximately 4 miles of 115kV.	Current Study	\$134,688.02	\$2,000,000
Spearville - Axtel 345kV CKT 1(North of GEN-2010-016 Tap) Balanced Portfolio: Spearville - Post Rock - Axtel 345kV CKT (Total Project E&C Cost Shown).	Previously Allocated		\$112,700,000
Axtel - Post Rock 345kV CKT 1 Balanced Portfolio: Spearville - Post Rock - Axtel 345kV CKT (Total Project E&C Cost Shown).	Previously Allocated		\$112,700,000
Comanche - Medicine Lodge 345kV CKT 1 Priority Project: Spearville - Comanche - Med Lodge - Wichita Dbl 345kV CKT (Total Project E&C Cost Shown).	Previously Allocated		\$356,300,000
Comanche - Medicine Lodge 345kV CKT 2 Priority Project: Spearville - Comanche - Med Lodge - Wichita Dbl 345kV CKT (Total Project E&C Cost Shown).	Previously Allocated		\$356,300,000
Spearville - Comanche 345kV CKT 1 Priority Project: Spearville - Comanche - Med Lodge - Wichita Dbl 345kV CKT (Total Project E&C Cost Shown).	Previously Allocated		\$356,300,000
Spearville - Comanche 345kV CKT 2 Priority Project: Spearville - Comanche - Med Lodge - Wichita Dbl 345kV CKT (Total Project E&C Cost Shown).	Previously Allocated		\$356,300,000
Medicine Lodge - Wichita 345kV Priority Project: Spearville - Comanche - Med Lodge - Wichita Dbl 345kV CKT (Total Project E&C Cost Shown).	Previously Allocated		\$356,300,000
	Current Study Total	\$11,858,665.50	
TOTAL CURRENT STUDY COSTS		\$350,428,785	

* Current Study Requests' Costs of Previously Allocated Network Upgrades will be determined by a restudy, if necessary.

F: Cost Allocation per Proposed Study Network Upgrade

This section shows each Direct Assigned Facility and Network Upgrade and the Generation Interconnection Request Customer(s) which have an impact in this study assuming all higher queued projects remain in the queue and achieve commercial operation.

The required interconnection costs listed do not include all costs associated with the deliverability of the energy to final customers. These costs are determined by separate studies if the Customer submits a Transmission Service Request through SPP's Open Access Same Time Information System (OASIS) as required by Attachment Z1 of the SPP OATT. In addition, costs associated with a short circuit analysis will be allocated should the Interconnection Request Customer choose to execute a Facility Study Agreement.

There may be additional costs allocated to each Customer. See Appendix E for more details.

Appendix F. - Cost Allocation Per Upgrade Facility - DIS-2010-001

Upgrade Facility and Designated Requests	Allocated Costs	E + C Costs
<u>ASGI-2010-010 Interconnection Costs</u>		
See Online Diagram.		\$1
ASGI-2010-010	\$1.00	
Total	\$1.00	
<u>ASGI-2010-011 Interconnection Costs</u>		
See Online Diagram.		\$1
ASGI-2010-011	\$1.00	
Total	\$1.00	
<u>Cimarron River Plant - Cimarron River Tap 115kV CKT 1</u>		
Rebuild approximately 4 miles of 115kV.		\$2,000,000
GEN-2009-059	\$1,677,185.93	
GEN-2010-015	\$188,126.05	
GEN-2010-016	\$134,688.02	
Total	\$2,000,000.00	
<u>Fargo Junction - Woodward 69kV CKT 1</u>		
Rebuild approximately 2 miles of 69kV.		\$750,000
GEN-2010-008	\$750,000.00	
Total	\$750,000.00	
<u>GEN-2008-022 Interconnection Costs</u>		
See Online Diagram.		\$13,000,000
GEN-2008-022	\$13,000,000.00	
Total	\$13,000,000.00	
<u>GEN-2008-037 Interconnection Costs</u>		
See Online Diagram.		\$1,500,000
GEN-2008-037	\$1,500,000.00	
Total	\$1,500,000.00	
<u>GEN-2008-044 Interconnection Costs</u>		
See Online Diagram.		\$3,403,020
GEN-2008-044	\$3,403,020.00	
Total	\$3,403,020.00	
<u>GEN-2008-046 Interconnection Costs</u>		
See Online Diagram.		\$3,073,333
GEN-2008-046	\$3,073,333.00	
Total	\$3,073,333.00	
<u>GEN-2008-047 Interconnection Costs</u>		
See Online Diagram.		\$10,000,000
GEN-2008-047	\$10,000,000.00	
Total	\$10,000,000.00	

Upgrade Facility and Designated Requests	Allocated Costs	E + C Costs
<u>GEN-2008-071 Interconnection Costs</u>		\$4,000,000
See Online Diagram.		
GEN-2008-071	\$4,000,000.00	
Total	\$4,000,000.00	
<u>GEN-2008-079 Tap - Spearville 115KV CKT 1</u>		\$16,000,000
Construct approximately 40 miles of new 115kV.		
GEN-2009-059	\$11,522,174.39	
GEN-2009-062	\$4,477,825.61	
Total	\$16,000,000.00	
<u>GEN-2008-088 Interconnection Costs</u>		\$2,884,830
See Online Diagram.		
GEN-2008-088	\$2,884,830.00	
Total	\$2,884,830.00	
<u>GEN-2008-098 Interconnection Costs</u>		\$8,259,000
See Online Diagram.		
GEN-2008-098	\$8,259,000.00	
Total	\$8,259,000.00	
<u>GEN-2008-110 Interconnection Costs</u>		\$2,500,000
See Online Diagram.		
GEN-2008-110	\$2,500,000.00	
Total	\$2,500,000.00	
<u>GEN-2008-123N Interconnection Costs</u>		\$6,200,000
See Online Diagram. Includes 115kV breakers at Guide Rock.		
GEN-2008-123N	\$6,200,000.00	
Total	\$6,200,000.00	
<u>GEN-2009-008 Interconnection Costs</u>		\$1,800,000
See Online Diagram.		
GEN-2009-008	\$1,800,000.00	
Total	\$1,800,000.00	
<u>GEN-2009-020 Interconnection Costs</u>		\$1,800,000
See Online Diagram.		
GEN-2009-020	\$1,800,000.00	
Total	\$1,800,000.00	
<u>GEN-2009-030 Interconnection Costs</u>		\$2,000,000
See Online Diagram.		
GEN-2009-030	\$2,000,000.00	
Total	\$2,000,000.00	
<u>GEN-2009-032S Interconnection Costs</u>		\$238,259
GEN-2009-032S	\$238,259.00	
Total	\$238,259.00	

Upgrade Facility and Designated Requests	Allocated Costs	E + C Costs
<u>GEN-2009-040 Interconnection Costs</u>		\$5,240,000
See Online Diagram.		
GEN-2009-040	\$5,240,000.00	
Total	\$5,240,000.00	
<u>GEN-2009-059 Interconnection Costs</u>		\$3,800,000
See Online Diagram.		
GEN-2009-059	\$3,800,000.00	
Total	\$3,800,000.00	
<u>GEN-2009-060 Interconnection Costs</u>		\$1,000,000
See Online Diagram.		
GEN-2009-060	\$1,000,000.00	
Total	\$1,000,000.00	
<u>GEN-2009-062 Interconnection Costs</u>		\$1,800,000
See Online Diagram.		
GEN-2009-062	\$1,800,000.00	
Total	\$1,800,000.00	
<u>GEN-2009-067S Interconnection Costs</u>		\$1,306,757
See Online Diagram.		
GEN-2009-067S	\$1,306,757.00	
Total	\$1,306,757.00	
<u>GEN-2010-003 Interconnection Costs</u>		\$26,000
See Online Diagram.		
GEN-2010-003	\$26,000.00	
Total	\$26,000.00	
<u>GEN-2010-005 Interconnection Costs</u>		\$26,000
See Online Diagram.		
GEN-2010-005	\$26,000.00	
Total	\$26,000.00	
<u>GEN-2010-006 Interconnection Costs</u>		\$1,408,514
See Online Diagram.		
GEN-2010-006	\$1,408,514.00	
Total	\$1,408,514.00	
<u>GEN-2010-007 Interconnection Costs</u>		\$2,867,363
See Online Diagram.		
GEN-2010-007	\$2,867,363.00	
Total	\$2,867,363.00	
<u>GEN-2010-008 Interconnection Costs</u>		\$750,000
See Online Diagram.		
GEN-2010-008	\$750,000.00	
Total	\$750,000.00	

Upgrade Facility and Designated Requests	Allocated Costs	E + C Costs
<u>GEN-2010-009 Interconnection Costs</u>		
See Oonline Diagram.		\$7,500,000
GEN-2010-009	\$7,500,000.00	
Total	\$7,500,000.00	
<u>GEN-2010-011 Interconnection Costs</u>		
See Oonline Diagram.		\$1
GEN-2010-011	\$1.00	
Total	\$1.00	
<u>GEN-2010-013 Interconnection Costs</u>		
See Oonline Diagram.		\$1,692,000
GEN-2010-013	\$1,692,000.00	
Total	\$1,692,000.00	
<u>GEN-2010-014 Interconnection Costs</u>		
See Oonline Diagram.		\$2,500,000
GEN-2010-014	\$2,500,000.00	
Total	\$2,500,000.00	
<u>GEN-2010-015 Interconnection Costs</u>		
See Oonline Diagram.		\$7,500,000
GEN-2010-015	\$7,500,000.00	
Total	\$7,500,000.00	
<u>GEN-2010-016 Interconnection Costs</u>		
See Oonline Diagram.		\$10,000,000
GEN-2010-016	\$10,000,000.00	
Total	\$10,000,000.00	
<u>Hitchland - Border 345kV Double CKT</u>		
Build approximately 105 miles of 345kV.		\$128,120,399
ASGI-2010-011	\$6,115,405.62	
GEN-2008-047	\$15,968,985.49	
GEN-2008-088	\$2,716,981.04	
GEN-2008-110	\$44,517,855.24	
GEN-2010-007	\$5,528,138.15	
GEN-2010-014	\$53,273,033.44	
Total	\$128,120,398.98	
<u>Hitchland 230/115/13.2kV Transformer CKT 2</u>		
DISIS-2010-001 Restudy		\$3,000,000
ASGI-2010-011	\$2,116,488.34	
GEN-2010-007	\$883,511.66	
Total	\$3,000,000.00	

Upgrade Facility and Designated Requests	Allocated Costs	E + C Costs
<u>Lake Creek - Lone Wolf 69kV CKT 1</u>		\$200,000
Reset CT.		
GEN-2008-037	\$2,027.60	
GEN-2009-060	\$197,972.40	
Total	\$200,000.00	
<u>Madison County 230kV Substation</u>		\$3,600,000
See Oneline Diagram.		
GEN-2006-044N02	\$1,800,000.00	
GEN-2010-010	\$1,800,000.00	
Total	\$3,600,000.00	
<u>Madison County Tap 230/115/13.8kV Transformer CKT 1</u>		\$19,100,000
Install 230/115/13.8kV Transformer and Associated 230kV ring bus and 115kv ring bus at New Madison County Tap.		
GEN-2006-044N02	\$9,550,000.00	
GEN-2010-010	\$9,550,000.00	
Total	\$19,100,000.00	
<u>Norfolk - Madison County Tap 115kV CKT 1</u>		\$18,800,000
Build approximately 20 miles of 115kV between Norfolk and new tap on Petersburg - Madison 115kV CKT 1.		
GEN-2006-044N02	\$9,400,000.00	
GEN-2010-010	\$9,400,000.00	
Total	\$18,800,000.00	
<u>Post Rock 345/230/13.8kV Transformer CKT 2</u>		\$8,000,000
DISIS-2010-001 Restudy		
GEN-2009-008	\$4,549,291.69	
GEN-2009-020	\$323,940.30	
GEN-2009-059	\$223,881.00	
GEN-2009-062	\$183,127.29	
GEN-2010-009	\$388,511.21	
GEN-2010-015	\$607,271.02	
GEN-2010-016	\$1,723,977.48	
Total	\$7,999,999.99	
<u>South Hays - Hays Plant - Vine Street 115kV CKT 1</u>		\$3,200,000
Rebuild approximately 4 miles of 115kV.		
GEN-2009-008	\$3,020,205.00	
GEN-2009-020	\$179,795.00	
Total	\$3,200,000.00	
<u>Spearville 345/115/13.8kV Transfomer CKT 1</u>		\$10,000,000
New 345/115kV Spearville Transformer		
GEN-2009-059	\$7,320,757.00	
GEN-2009-062	\$2,679,243.00	
Total	\$10,000,000.00	

Upgrade Facility and Designated Requests	Allocated Costs	E + C Costs
<hr/>		
<u>Switch 2749 - Wildorado 69kV CKT 1</u>		\$1,461,321
Rebuild approximately 4 miles of 69kV.		
GEN-2008-088	\$1,461,321.00	
	Total	\$1,461,321.00
<hr/>		
<u>Washita - Gracemont 138kV CKT 2</u>		\$5,621,986
Build approximately 11 miles of 138kV.		
GEN-2008-037	\$2,903,533.08	
GEN-2009-030	\$2,007,857.24	
GEN-2009-060	\$710,595.67	
	Total	\$5,621,985.99
<hr/>		
<u>Washita - Weatherford 138kV CKT 1</u>		\$22,500,000
Build approximately 50 miles of 138kV.		
GEN-2009-030	\$22,435,002.31	
GEN-2009-060	\$64,997.69	
	Total	\$22,500,000.00
<hr/>		
TOTAL CURRENT STUDY UPGRADE COST		\$350,428,785

G: Powerflow Analysis with Constraints for Mitigation

G-1

Definitive Interconnection System Impact Study for Grouped Generation Interconnection Requests – (DISIS-2010-001)

SPP RESTRICTED

SOLUTION GROUP	SCENARIO	SEASON	SOURCE	DIRECTION	MONITORED ELEMENT	COMMON NAME	RATEB	TDF	TC%	LOAD CONTINGENCY	NAME
	00ASGL1C	0 11SP	ASGL_2010_010		Non Converged		480	0.00357	52.73396	'STEGALL - STEGALL TRANSFORMER 230KV CKT 1'	
FDNS	2	0 11G	ASGL_2010_011	'TO->FROM'	'FINNEY SWITCHING STATION - STEVENSCO	345.00	1052	0.43806	111.9602	'DBL-HIT-G084'	
FNSL-Itera	2	0 11G	ASGL_2010_011		Non Converged		0	0.39219	9999	'DBL-G0847-WO'	
FDNS	2	0 11G	ASGL_2010_011	'TO->FROM'	'FINNEY SWITCHING STATION - STEVENSCO	345.00	1052	0.43806	111.9602	'DBL-HIT-G084'	
FNSL-Itera	2	0 11G	ASGL_2010_011		Non Converged		0	0.39219	9999	'DBL-G0847-WO'	
FDNS	2	2 11G	ASGL_2010_011	'FROM->TO'	'HITCHLAND INTERCHANGE (H TP80148301) 230/115/'		250	0.60268	97.7	'G05-17T 345.00 - Hitchland Interchange 345KV CKT 1'	
FDNS	2	2 11G	ASGL_2010_011	'FROM->TO'	'HITCHLAND INTERCHANGE (H TP80148301) 230/115/'		250	0.60268	97.6	'G05-17T 345.00 - Hitchland Interchange 345KV CKT 1'	
FDNS	2	2 11G	ASGL_2010_011	'FROM->TO'	'HITCHLAND INTERCHANGE (H TP80148301) 230/115/'		250	0.69368	97.5	'Hansford County Switch Station - SPEARMAN INTERCHANGE 115F'	
FDNS	2	2 11G	ASGL_2010_011	'FROM->TO'	'HITCHLAND INTERCHANGE (H TP80148301) 230/115/'		250	0.69368	97.7	'Hansford County Switch Station - SPEARMAN INTERCHANGE 115F'	
FDNS	2	2 11G	ASGL_2010_011	'FROM->TO'	'Hansford County Switch Station - SPEARMAN INTERCH		160	0.43094	96.1	'HITCHLAND INTERCHANGE (H TP80148301) 230/115/13.2KV TRA	
FDNS	2	2 11G	ASGL_2010_011	'FROM->TO'	'HITCHLAND INTERCHANGE (H TP80148301) 230/115/'		250	0.60268	97.7	'G05-17T 345.00 - Hitchland Interchange 345KV CKT 1'	
FDNS	2	2 11G	ASGL_2010_011	'FROM->TO'	'HITCHLAND INTERCHANGE (H TP80148301) 230/115/'		250	0.60268	97.6	'G05-17T 345.00 - Hitchland Interchange 345KV CKT 1'	
FDNS	2	2 11G	ASGL_2010_011	'FROM->TO'	'HITCHLAND INTERCHANGE (H TP80148301) 230/115/'		250	0.69368	97.5	'Hansford County Switch Station - SPEARMAN INTERCHANGE 115F'	
FDNS	2	2 11G	ASGL_2010_011	'FROM->TO'	'HITCHLAND INTERCHANGE (H TP80148301) 230/115/'		250	0.69368	97.7	'Hansford County Switch Station - SPEARMAN INTERCHANGE 115F'	
FDNS	2	2 11G	ASGL_2010_011	'FROM->TO'	'Hansford County Switch Station - SPEARMAN INTERCH		160	0.43094	96.1	'HITCHLAND INTERCHANGE (H TP80148301) 230/115/13.2KV TRA	
FDNS	02ALL	0 11G	ASGL_2010_011	'FROM->TO'	'HITCHLAND INTERCHANGE (H TP80148301) 230/115/'		250	0.6099	100.5997	'LAWTON EASTSIDE - OKLAUNION 345KV CKT 1'	
FDNS	02ALL	0 11G	ASGL_2010_011	'FROM->TO'	'HITCHLAND INTERCHANGE (H TP80148301) 230/115/'		250	0.6099	100.5731	'LAWTON EASTSIDE - OKLAUNION 345KV CKT 1'	
FDNS	02ALL	0 11G	ASGL_2010_011	'FROM->TO'	'HITCHLAND INTERCHANGE (H TP80148301) 230/115/'		250	0.61197	102.3005	'ELK CITY 230KV - SWEETWT6 230.00 230KV CKT 1'	
FDNS	02ALL	0 11G	ASGL_2010_011	'FROM->TO'	'HITCHLAND INTERCHANGE (H TP80148301) 230/115/'		250	0.61197	102.3627	'ELK CITY 230KV - SWEETWT6 230.00 230KV CKT 1'	
FNSL-Blow 02ALL	0 11G	ASGL_2010_011			Non Converged		1052	0.24914	86.2944	'FINNEY SWITCHING STATION - STEVENSCO 345.00 345KV CK'	
FNSL-Blow 02ALL	0 11G	ASGL_2010_011			Non Converged		0	0.21026	9999	'DBL-HIT-G084'	
FNSL-Blow 02ALL	0 11G	ASGL_2010_011			Non Converged		0	0.21026	9999	'DBL-G0847-WO'	
FDNS	02ALL	0 11G	ASGL_2010_011	'FROM->TO'	'HITCHLAND INTERCHANGE (H TP80148301) 230/115/'		250	0.69832	103.1282	'TEXAS COUNTY INTERCHANGE - TRI COUNTY REC-GUYMON 1	
FDNS	02ALL	0 11G	ASGL_2010_011	'FROM->TO'	'HITCHLAND INTERCHANGE (H TP80148301) 230/115/'		250	0.69832	103.9031	'TEXAS COUNTY INTERCHANGE - TRI COUNTY REC-GUYMON 1	
FDNS	02ALL	0 11G	ASGL_2010_011	'FROM->TO'	'HITCHLAND INTERCHANGE (H TP80148301) 230/115/'		250	0.67146	103.7915	'DWS_FRISCO 3115.00 - HITCHLAND INTERCHANGE 115KV CKT	
FDNS	02ALL	0 11G	ASGL_2010_011	'FROM->TO'	'HITCHLAND INTERCHANGE (H TP80148301) 230/115/'		250	0.67146	104.6666	'DWS_FRISCO 3115.00 - HITCHLAND INTERCHANGE 115KV CKT	
FDNS	02ALL	0 11G	ASGL_2010_011	'FROM->TO'	'HITCHLAND INTERCHANGE (H TP80148301) 230/115/'		250	0.60334	101.6998	'G05-17T 345.00 - Hitchland Interchange 345KV CKT 1'	
FDNS	02ALL	0 11G	ASGL_2010_011	'FROM->TO'	'HITCHLAND INTERCHANGE (H TP80148301) 230/115/'		250	0.60334	101.8499	'G05-17T 345.00 - Hitchland Interchange 345KV CKT 1'	
FDNS	02ALL	0 11G	ASGL_2010_011	'FROM->TO'	'HITCHLAND INTERCHANGE (H TP80148301) 230/115/'		250	0.69832	102.2004	'TRI COUNTY REC-COLE - TRI COUNTY REC-GUYMON 115KV CK	
FDNS	02ALL	0 11G	ASGL_2010_011	'FROM->TO'	'HITCHLAND INTERCHANGE (H TP80148301) 230/115/'		250	0.69832	102.9551	'TRI COUNTY REC-COLE - TRI COUNTY REC-GUYMON 115KV Ch	
FDNS	02ALL	0 11G	ASGL_2010_011	'FROM->TO'	'HITCHLAND INTERCHANGE (H TP80148301) 230/115/'		250	0.67136	108.8915	'DWS_FRISCO 3115.00 - SHERMAN COUNTY TAP 115KV CKT 1'	
FDNS	02ALL	0 11G	ASGL_2010_011	'FROM->TO'	'HITCHLAND INTERCHANGE (H TP80148301) 230/115/'		250	0.67136	109.8006	'DWS_FRISCO 3115.00 - SHERMAN COUNTY TAP 115KV CKT 1'	
FDNS	02ALL	0 11G	ASGL_2010_011	'FROM->TO'	'HITCHLAND INTERCHANGE (H TP80148301) 230/115/'		250	0.69943	117.3039	'Hansford County Switch Station - SPEARMAN INTERCHANGE 115F'	
FDNS	02ALL	0 11G	ASGL_2010_011	'FROM->TO'	'HITCHLAND INTERCHANGE (H TP80148301) 230/115/'		250	0.69943	118.7255	'Hansford County Switch Station - SPEARMAN INTERCHANGE 115F'	
FDNS	02ALL	0 11G	ASGL_2010_011	'FROM->TO'	'HITCHLAND INTERCHANGE (H TP80148301) 230/115/'		250	0.61224	100.3809	'GRAPEVINE INTERCHANGE - STATELINE INTERCHANGE 230KV	
FDNS	02ALL	0 11G	ASGL_2010_011	'FROM->TO'	'HITCHLAND INTERCHANGE (H TP80148301) 230/115/'		250	0.61224	100.3187	'GRAPEVINE INTERCHANGE - STATELINE INTERCHANGE 230KV	
FDNS	02ALL	0 11G	ASGL_2010_011	'FROM->TO'	'HITCHLAND INTERCHANGE (H TP80148301) 230/115/'		250	0.60635	102.6	'G06-49 345.00 - STEVENSCO 345.00 345KV CKT 1'	
FDNS	02ALL	0 11G	ASGL_2010_011	'FROM->TO'	'HITCHLAND INTERCHANGE (H TP80148301) 230/115/'		250	0.60635	101.6	'G10-14 345.00 345/115KV TRANSFORMER CKT 1'	
FDNS	02ALL	0 11G	ASGL_2010_011	'FROM->TO'	'HITCHLAND INTERCHANGE (H TP80148301) 230/115/'		250	0.60635	101.6	'2008-047 TP345.00 - G10-14 345.00 345KV CKT 1'	
FDNS	02ALL	0 11G	ASGL_2010_011	'FROM->TO'	'HITCHLAND INTERCHANGE (H TP80148301) 230/115/'		250	0.61197	102.2998	'ELK CITY 230KV (ELKCTY-6) 230/138/13.8KV TRANSFORMER CK	
FDNS	02ALL	0 11G	ASGL_2010_011	'FROM->TO'	'HITCHLAND INTERCHANGE (H TP80148301) 230/115/'		250	0.61197	102.3621	'ELK CITY 230KV (ELKCTY-6) 230/138/13.8KV TRANSFORMER CK	
FDNS	02ALL	0 11G	ASGL_2010_011	'FROM->TO'	'Hansford County Switch Station - SPEARMAN INTERCH		160	0.43667	127.6315	'HITCHLAND INTERCHANGE (H TP80148301) 230/115/13.2KV TRA	
FDNS	02ALL	0 11G	ASGL_2010_011	'FROM->TO'	'HITCHLAND INTERCHANGE (H TP80148301) 230/115/'		250	0.60635	100.6	'Hitchland Interchange 345/0.575KV TRANSFORMER CKT 1'	
FDNS	02ALL	0 11G	ASGL_2010_011	'FROM->TO'	'HITCHLAND INTERCHANGE (H TP80148301) 230/115/'		250	0.60635	102.6	'G06-49 345.00 345/34.5KV TRANSFORMER CKT 1'	
FDNS	02ALL	0 11G	ASGL_2010_011	'FROM->TO'	'HITCHLAND INTERCHANGE (H TP80148301) 230/115/'		250	0.61224	100.5668	'SPP-SWPS-03'	
FDNS	02ALL	0 11G	ASGL_2010_011	'FROM->TO'	'HITCHLAND INTERCHANGE (H TP80148301) 230/115/'		250	0.61224	100.4752	'SPP-SWPS-03'	
FDNS	02ALL	0 11G	ASGL_2010_011	'FROM->TO'	'HITCHLAND INTERCHANGE (H TP80148301) 230/115/'		250	0.69832	103.2832	'SPP-SWPS-T01'	
FDNS	02ALL	0 11G	ASGL_2010_011	'FROM->TO'	'HITCHLAND INTERCHANGE (H TP80148301) 230/115/'		250	0.69832	104.0598	'SPP-SWPS-T01'	
FDNS	02ALL	0 11G	ASGL_2010_011	'FROM->TO'	'HITCHLAND INTERCHANGE (H TP80148301) 230/115/'		250	0.6099	100.5997	'LAWTON EASTSIDE - OKLAUNION 345KV CKT 1'	
FDNS	02ALL	0 11G	ASGL_2010_011	'FROM->TO'	'HITCHLAND INTERCHANGE (H TP80148301) 230/115/'		250	0.6099	100.5731	'LAWTON EASTSIDE - OKLAUNION 345KV CKT 1'	
FDNS	02ALL	0 11G	ASGL_2010_011	'FROM->TO'	'HITCHLAND INTERCHANGE (H TP80148301) 230/115/'		250	0.61197	102.3005	'ELK CITY 230KV - SWEETWT6 230.00 230KV CKT 1'	
FDNS	02ALL	0 11G	ASGL_2010_011	'FROM->TO'	'HITCHLAND INTERCHANGE (H TP80148301) 230/115/'		250	0.61197	102.3627	'ELK CITY 230KV - SWEETWT6 230.00 230KV CKT 1'	
FNSL-Blow 02ALL	0 11G	ASGL_2010_011			Non Converged		1052	0.24914	86.2944	'FINNEY SWITCHING STATION - STEVENSCO 345.00 345KV CK'	
FNSL-Blow 02ALL	0 11G	ASGL_2010_011			Non Converged		0	0.21026	9999	'DBL-HIT-G084'	
FNSL-Blow 02ALL	0 11G	ASGL_2010_011			Non Converged		0	0.21026	9999	'DBL-G0847-WO'	
FDNS	02ALL	0 11G	ASGL_2010_011	'FROM->TO'	'HITCHLAND INTERCHANGE (H TP80148301) 230/115/'		250	0.69832	103.1282	'TEXAS COUNTY INTERCHANGE - TRI COUNTY REC-GUYMON 1	
FDNS	02ALL	0 11G	ASGL_2010_011	'FROM->TO'	'HITCHLAND INTERCHANGE (H TP80148301) 230/115/'		250	0.69832	103.9031	'TEXAS COUNTY INTERCHANGE - TRI COUNTY REC-GUYMON 1	
FDNS	02ALL	0 11G	ASGL_2010_011	'FROM->TO'	'HITCHLAND INTERCHANGE (H TP80148301) 230/115/'		250	0.67146	103.7915	'DWS_FRISCO 3115.00 - HITCHLAND INTERCHANGE 115KV CKT	
FDNS	02ALL	0 11G	ASGL_2010_011	'FROM->TO'	'HITCHLAND INTERCHANGE (H TP80148301) 230/115/'		250	0.67146	104.6666	'DWS_FRISCO 3115.00 - HITCHLAND INTERCHANGE 115KV CKT	
FDNS	02ALL	0 11G	ASGL_2010_011	'FROM->TO'	'HITCHLAND INTERCHANGE (H TP80148301) 230/115/'		250	0.60334	101.6998	'G05-17T 345.00 - Hitchland Interchange 345KV CKT 1'	
FDNS	02ALL	0 11G	ASGL_2010_011	'FROM->TO'	'HITCHLAND INTERCHANGE (H TP80148301) 230/115/'		250	0.60334	101.8499	'G05-17T 345.00 - Hitchland Interchange 345KV CKT 1'	
FDNS	02ALL	0 11G	ASGL_2010_011	'FROM->TO'	'HITCHLAND INTERCHANGE (H TP80148301) 230/115/'		250	0.69832	102.2004	'TRI COUNTY REC-COLE - TRI COUNTY REC-GUYMON 115KV CK	
FDNS	02ALL	0 11G	ASGL_2010_011	'FROM->TO'	'HITCHLAND INTERCHANGE (H TP80148301) 230/115/'		250	0.69832	102.9551	'TRI COUNTY REC-COLE - TRI COUNTY REC-GUYMON 115KV CK	
FDNS	02ALL	0 11G	ASGL_2010_011	'FROM->TO'	'HITCHLAND INTERCHANGE (H TP80148301) 230/115/'		250	0.67136	108.8915	'DWS_FRISCO 3115.00 - SHERMAN COUNTY TAP 115KV CKT 1'	
FDNS	02ALL	0 11G	ASGL_2010_011	'FROM->TO'	'HITCHLAND INTERCHANGE (H TP80148301) 230/115/'		250	0.67136	109.8006	'DWS_FRISCO 3115.00 - SHERMAN COUNTY TAP 115KV CKT 1'	
FDNS	02ALL	0 11G	ASGL_2010_011	'FROM->TO'	'HITCHLAND INTERCHANGE (H TP80148301) 230/115/'		250	0.69943	117.3039	'Hansford County Switch Station - SPEARMAN INTERCHANGE 115F'	
FDNS	02ALL	0 11G	ASGL_2010_011	'FROM->TO'	'HITCHLAND INTERCHANGE (H TP80148301) 230/115/'		250	0.69943	118.7255	'Hansford County Switch Station - SPEARMAN INTERCHANGE 115F'	

SOLUTION GROUP	SCENARI	SEASON	SOURCE	DIRECTION	MONITORED ELEMENT	COMMON NAME	RATEB	TDF	TC%	LOAD	CONTINGENCY	NAME
FDNS	02ALL	0 11G	ASGL_2010_011	'FROM->TO'	'HITCHLAND INTERCHANGE (H TP80148301)	230/115/'	250	0.61224	100.3809	'GRAPEVINE INTERCHANGE - STATELINE INTERCHANGE	230KV	
FDNS	02ALL	0 11G	ASGL_2010_011	'FROM->TO'	'HITCHLAND INTERCHANGE (H TP80148301)	230/115/'	250	0.61224	100.3187	'GRAPEVINE INTERCHANGE - STATELINE INTERCHANGE	230KV	
FDNS	02ALL	0 11G	ASGL_2010_011	'FROM->TO'	'HITCHLAND INTERCHANGE (H TP80148301)	230/115/'	250	0.60635	102.6	'G06-49 345.00 - STEVENSCO	345.00 345KV CKT 1'	
FDNS	02ALL	0 11G	ASGL_2010_011	'FROM->TO'	'HITCHLAND INTERCHANGE (H TP80148301)	230/115/'	250	0.60635	101.6	'G10-14 345.00 345/115KV TRANSFORMER	CKT 1'	
FDNS	02ALL	0 11G	ASGL_2010_011	'FROM->TO'	'HITCHLAND INTERCHANGE (H TP80148301)	230/115/'	250	0.60635	101.6	'2008-047 TP345.00 - G10-14	345.00 345KV CKT 1'	
FDNS	02ALL	0 11G	ASGL_2010_011	'FROM->TO'	'HITCHLAND INTERCHANGE (H TP80148301)	230/115/'	250	0.61197	102.2998	'ELK CITY 230KV (ELKCTY-6) 230/138/13.8KV	TRANSFORMER CK	
FDNS	02ALL	0 11G	ASGL_2010_011	'FROM->TO'	'HITCHLAND INTERCHANGE (H TP80148301)	230/115/'	250	0.61197	102.3621	'ELK CITY 230KV (ELKCTY-6) 230/138/13.8KV	TRANSFORMER CK	
FDNS	02ALL	0 11G	ASGL_2010_011	'FROM->TO'	'Hansford County Switch Station - SPEARMAN INTERCH		160	0.43667	127.6315	'HITCHLAND INTERCHANGE (H TP80148301)	230/115/13.2KV TR#	
FDNS	02ALL	0 11G	ASGL_2010_011	'FROM->TO'	'HITCHLAND INTERCHANGE (H TP80148301)	230/115/'	250	0.60635	100.6	'Hitchland Interchange 345/0.575KV	TRANSFORMER CKT 1'	
FDNS	02ALL	0 11G	ASGL_2010_011	'FROM->TO'	'HITCHLAND INTERCHANGE (H TP80148301)	230/115/'	250	0.60635	102.6	'G06-49 345.00 345/34.5KV	TRANSFORMER CKT 1'	
FDNS	02ALL	0 11G	ASGL_2010_011	'FROM->TO'	'HITCHLAND INTERCHANGE (H TP80148301)	230/115/'	250	0.61224	100.5668	'SPP-SWPS-03'		
FDNS	02ALL	0 11G	ASGL_2010_011	'FROM->TO'	'HITCHLAND INTERCHANGE (H TP80148301)	230/115/'	250	0.61224	100.4752	'SPP-SWPS-03'		
FDNS	02ALL	0 11G	ASGL_2010_011	'FROM->TO'	'HITCHLAND INTERCHANGE (H TP80148301)	230/115/'	250	0.69832	103.2832	'SPP-SWPS-T01'		
FDNS	02ALL	0 11G	ASGL_2010_011	'FROM->TO'	'HITCHLAND INTERCHANGE (H TP80148301)	230/115/'	250	0.69832	104.0598	'SPP-SWPS-T01'		
FDNS	02ALL	0 11G	ASGL_2010_011	'TO->FROM'	'FINNEY SWITCHING STATION - STEVENSCO	345.00	1052	0.20232	97.3	'BASE CASE'		
FDNS	02ALL	0 11G	ASGL_2010_011	'TO->FROM'	'FINNEY SWITCHING STATION - STEVENSCO	345.00	1052	0.21308	100.4567	'LAWTON EASTSIDE - OKLAUNION	345KV CKT 1'	
FDNS	02ALL	0 11G	ASGL_2010_011	'TO->FROM'	'FINNEY SWITCHING STATION - STEVENSCO	345.00	1052	0.21308	95	'G05-15T 345.00 - OKLAUNION	345KV CKT 1'	
FDNS	02ALL	0 11G	ASGL_2010_011	'TO->FROM'	'NORTHWEST - TATONGA7	345.00 345KV CKT 1'	1195	0.1964	108.4191	'DBL-WOOD-MED'		
FDNS	02ALL	0 11G	ASGL_2010_011	'TO->FROM'	'FINNEY SWITCHING STATION - STEVENSCO	345.00	1052	0.26163	115.9808	'DBL-WOOD-MED'		
FDNS	02ALL	0 11G	ASGL_2010_011	'FROM->TO'	'HITCHLAND INTERCHANGE (H TP80148301)	230/115/'	250	0.6016	95.2	'SPP-SWPS-02'		
FDNS	02ALL	0 11G	ASGL_2010_011	'FROM->TO'	'HITCHLAND INTERCHANGE (H TP80148301)	230/115/'	250	0.6016	95.4	'SPP-SWPS-02'		
FDNS	02ALL	0 11G	ASGL_2010_011	'FROM->TO'	'HITCHLAND INTERCHANGE (H TP80148301)	230/115/'	250	0.6016	95.2	'SPP-SWPS-02A'		
FDNS	02ALL	0 11G	ASGL_2010_011	'FROM->TO'	'HITCHLAND INTERCHANGE (H TP80148301)	230/115/'	250	0.6016	95.3	'SPP-SWPS-02A'		
FDNS	02ALL	0 11G	ASGL_2010_011	'TO->FROM'	'FINNEY SWITCHING STATION - STEVENSCO	345.00	1052	0.21277	95.4	'SPP-SWPS-03'		
FDNS	02ALL	0 11G	ASGL_2010_011	'FROM->TO'	'HITCHLAND INTERCHANGE (H TP80148301)	230/115/'	250	0.6016	95.8	'SPP-SWPS-03'		
FDNS	02ALL	0 11G	ASGL_2010_011	'FROM->TO'	'HITCHLAND INTERCHANGE (H TP80148301)	230/115/'	250	0.6016	96	'SPP-SWPS-03'		
FDNS	02ALL	0 11G	ASGL_2010_011	'FROM->TO'	'HITCHLAND INTERCHANGE (H TP80148301)	230/115/'	250	0.6873	98.6	'SPP-SWPS-T01'		
FDNS	02ALL	0 11G	ASGL_2010_011	'FROM->TO'	'HITCHLAND INTERCHANGE (H TP80148301)	230/115/'	250	0.6873	99.3	'SPP-SWPS-T01'		
FDNS	02ALL	0 11G	ASGL_2010_011	'TO->FROM'	'FINNEY SWITCHING STATION - STEVENSCO	345.00	1052	0.20232	98.1	'GEN531447 1-HOLCOMB	GENERATOR'	
FNSL-Blow	02ALL	0 11G	ASGL_2010_011		Non Converged		1052	0.20232	97.33807	'FINNEY SWITCHING STATION - STEVENSCO	345.00 345KV CKT	
FNSL-Blow	02ALL	0 11G	ASGL_2010_011		Non Converged		0	0.39621	9999	'DBL-HIT-G084'		
FNSL-Blow	02ALL	0 11G	ASGL_2010_011		Non Converged		0	0.37465	9999	'DBL-G0847-WO'		
FDNS	02ALL	0 11G	ASGL_2010_011	'TO->FROM'	'FINNEY SWITCHING STATION - STEVENSCO	345.00	1052	0.21208	96.7	'ELK CITY 230KV - SWEETWT6	230.00 230KV CKT 1'	
FDNS	02ALL	0 11G	ASGL_2010_011	'FROM->TO'	'HITCHLAND INTERCHANGE (H TP80148301)	230/115/'	250	0.60133	97	'ELK CITY 230KV - SWEETWT6	230.00 230KV CKT 1'	
FDNS	02ALL	0 11G	ASGL_2010_011	'FROM->TO'	'HITCHLAND INTERCHANGE (H TP80148301)	230/115/'	250	0.60133	97.4	'ELK CITY 230KV - SWEETWT6	230.00 230KV CKT 1'	
FDNS	02ALL	0 11G	ASGL_2010_011	'FROM->TO'	'HITCHLAND INTERCHANGE (H TP80148301)	230/115/'	250	0.6016	95.3	'STLN-DEMARC6230.00 - SWEETWT6	230.00 230KV CKT 1'	
FDNS	02ALL	0 11G	ASGL_2010_011	'FROM->TO'	'HITCHLAND INTERCHANGE (H TP80148301)	230/115/'	250	0.6016	95.4	'STLN-DEMARC6230.00 - SWEETWT6	230.00 230KV CKT 1'	
FDNS	02ALL	0 11G	ASGL_2010_011	'TO->FROM'	'FINNEY SWITCHING STATION - STEVENSCO	345.00	1052	0.21629	98.6	'NORTHWEST - TATONGA7	345.00 345KV CKT 1'	
FDNS	02ALL	0 11G	ASGL_2010_011	'TO->FROM'	'FINNEY SWITCHING STATION - STEVENSCO	345.00	1052	0.21708	96.7	'TATONGA7 345.00 - WWRDEHV7	345.00 345KV CKT 1'	
FDNS	02ALL	0 11G	ASGL_2010_011	'TO->FROM'	'FINNEY SWITCHING STATION - STEVENSCO	345.00	1052	0.23005	105.5006	'2008-047 TAP345.00 - WWRDEHV7	345.00 345KV CKT 1'	
FDNS	02ALL	0 11G	ASGL_2010_011	'TO->FROM'	'FINNEY SWITCHING STATION - STEVENSCO	345.00	1052	0.23005	105.5006	'2008-047 TAP345.00 - WWRDEHV7	345.00 345KV CKT 2'	
FDNS	02ALL	0 11G	ASGL_2010_011	'TO->FROM'	'FINNEY SWITCHING STATION - STEVENSCO	345.00	1052	0.21767	95.7	'MED-LDG5 345.00 - WWRDEHV7	345.00 345KV CKT 1'	
FDNS	02ALL	0 11G	ASGL_2010_011	'TO->FROM'	'FINNEY SWITCHING STATION - STEVENSCO	345.00	1052	0.21767	95.7	'MED-LDG5 345.00 - WWRDEHV7	345.00 345KV CKT 2'	
FDNS	02ALL	0 11G	ASGL_2010_011	'FROM->TO'	'HITCHLAND INTERCHANGE (H TP80148301)	230/115/'	250	0.6873	98.4	'TEXAS COUNTY INTERCHANGE - TRI COUNTY	REC-GUYMON 1	
FDNS	02ALL	0 11G	ASGL_2010_011	'FROM->TO'	'HITCHLAND INTERCHANGE (H TP80148301)	230/115/'	250	0.6873	99.2	'TEXAS COUNTY INTERCHANGE - TRI COUNTY	REC-GUYMON 1	
FDNS	02ALL	0 11G	ASGL_2010_011	'FROM->TO'	'HITCHLAND INTERCHANGE (H TP80148301)	230/115/'	250	0.66104	100	'DWS_FRISCO 3115.00 - HITCHLAND	INTERCHANGE 115KV CKT	
FDNS	02ALL	0 11G	ASGL_2010_011	'FROM->TO'	'HITCHLAND INTERCHANGE (H TP80148301)	230/115/'	250	0.66104	101.2041	'DWS_FRISCO 3115.00 - HITCHLAND	INTERCHANGE 115KV CKT	
FDNS	02ALL	0 11G	ASGL_2010_011	'FROM->TO'	'HITCHLAND INTERCHANGE (H TP80148301)	230/115/'	250	0.59615	99.5	'G10-14 345.00 - Hitchland Interchange	345KV CKT 1'	
FDNS	02ALL	0 11G	ASGL_2010_011	'TO->FROM'	'FINNEY SWITCHING STATION - STEVENSCO	345.00	1052	0.23165	99	'2008-047 TAP345.00 - Hitchland	Interchange 345KV CKT 1'	
FDNS	02ALL	0 11G	ASGL_2010_011	'TO->FROM'	'FINNEY SWITCHING STATION - STEVENSCO	345.00	1052	0.23165	99	'2008-047 TAP345.00 - Hitchland	Interchange 345KV CKT 2'	
FDNS	02ALL	0 11G	ASGL_2010_011	'FROM->TO'	'HITCHLAND INTERCHANGE (H TP80148301)	230/115/'	250	0.6873	97.5	'TRI COUNTY REC-COLE - TRI COUNTY	REC-GUYMON 115KV CK	
FDNS	02ALL	0 11G	ASGL_2010_011	'FROM->TO'	'HITCHLAND INTERCHANGE (H TP80148301)	230/115/'	250	0.6873	98.2	'TRI COUNTY REC-COLE - TRI COUNTY	REC-GUYMON 115KV CK	
FDNS	02ALL	0 11G	ASGL_2010_011	'FROM->TO'	'HITCHLAND INTERCHANGE (H TP80148301)	230/115/'	250	0.66056	105.0683	'DWS_FRISCO 3115.00 - SHERMAN	COUNTY TAP 115KV CKT 1'	
FDNS	02ALL	0 11G	ASGL_2010_011	'FROM->TO'	'HITCHLAND INTERCHANGE (H TP80148301)	230/115/'	250	0.66056	106.2648	'DWS_FRISCO 3115.00 - SHERMAN	COUNTY TAP 115KV CKT 1'	
FDNS	02ALL	0 11G	ASGL_2010_011	'FROM->TO'	'HITCHLAND INTERCHANGE (H TP80148301)	230/115/'	250	0.6238	95.2	'RB-SPURLOCK3115.00 - SHERMAN	COUNTY TAP 115KV CKT 1'	
FDNS	02ALL	0 11G	ASGL_2010_011	'FROM->TO'	'HITCHLAND INTERCHANGE (H TP80148301)	230/115/'	250	0.68764	114.425	'Hansford County Switch Station -	SPEARMAN INTERCHANGE 115k	
FDNS	02ALL	0 11G	ASGL_2010_011	'FROM->TO'	'HITCHLAND INTERCHANGE (H TP80148301)	230/115/'	250	0.68764	116.223	'Hansford County Switch Station -	SPEARMAN INTERCHANGE 115k	
FDNS	02ALL	0 11G	ASGL_2010_011	'FROM->TO'	'HITCHLAND INTERCHANGE (H TP80148301)	230/115/'	250	0.6016	96	'GRAPEVINE INTERCHANGE - STATELINE	INTERCHANGE 230KV	
FDNS	02ALL	0 11G	ASGL_2010_011	'FROM->TO'	'HITCHLAND INTERCHANGE (H TP80148301)	230/115/'	250	0.6016	96.1	'GRAPEVINE INTERCHANGE - STATELINE	INTERCHANGE 230KV	
FDNS	02ALL	0 11G	ASGL_2010_011	'FROM->TO'	'HITCHLAND INTERCHANGE (H TP80148301)	230/115/'	250	0.6016	95.2	'STATELINE INTERCHANGE - STLN-DEMARC	6230.00 230KV CKT	
FDNS	02ALL	0 11G	ASGL_2010_011	'FROM->TO'	'HITCHLAND INTERCHANGE (H TP80148301)	230/115/'	250	0.6016	95.4	'STATELINE INTERCHANGE - STLN-DEMARC	6230.00 230KV CKT	
FDNS	02ALL	0 11G	ASGL_2010_011	'FROM->TO'	'FINNEY SWITCHING STATION - HOLCOMB	345KV CKT	1052	0.19919	95.1	'FINNEY SWITCHING STATION -	HOLCOMB 345KV CKT 1'	
FDNS	02ALL	0 11G	ASGL_2010_011	'FROM->TO'	'FINNEY SWITCHING STATION - HOLCOMB	345KV CKT	1052	0.19919	95.1	'FINNEY SWITCHING STATION -	HOLCOMB 345KV CKT 2'	
FDNS	02ALL	0 11G	ASGL_2010_011	'FROM->TO'	'HITCHLAND INTERCHANGE (H TP80148301)	230/115/'	250	0.59615	98.7	'G06-49 345.00 - STEVENSCO	345.00 345KV CKT 1'	
FDNS	02ALL	0 11G	ASGL_2010_011	'FROM->TO'	'HITCHLAND INTERCHANGE (H TP80148301)	230/115/'	250	0.59615	95.2	'2008-047 TAP345.00 - G08-47	345.00 345KV CKT 1'	
FDNS	02ALL	0 11G	ASGL_2010_011	'FROM->TO'	'HITCHLAND INTERCHANGE (H TP80148301)	230/115/'	250	0.59615	99.5	'G10-14 345.00 345/115KV	TRANSFORMER CKT 1'	
FDNS	02ALL	0 11G	ASGL_2010_011	'FROM->TO'	'HITCHLAND INTERCHANGE (H TP80148301)	230/115/'	250	0.59615	95.8	'2008-047 TAP345.00 - G10-01	345.00 345KV CKT 1'	

SOLUTION GROUP	SCENARIK SEASON	SOURCE	DIRECTION	MONITORED ELEMENT COMMON NAME	RATEB	TDF	TC%	LOAD CONTINGENCY NAME
FDNS	02ALL	0 11G	ASGL_2010_011	TO->FROM	'FINNEY SWITCHING STATION - STEVENSCO 345.00	1052	0.21208	96.7 'ELK CITY 230KV (ELKCTY-6) 230/138/13.8KV TRANSFORMER CK
FDNS	02ALL	0 11G	ASGL_2010_011	FROM->TO	'HITCHLAND INTERCHANGE (H TP80148301) 230/115/'	250	0.60133	97 'ELK CITY 230KV (ELKCTY-6) 230/138/13.8KV TRANSFORMER CK
FDNS	02ALL	0 11G	ASGL_2010_011	FROM->TO	'HITCHLAND INTERCHANGE (H TP80148301) 230/115/'	250	0.60133	97.4 'ELK CITY 230KV (ELKCTY-6) 230/138/13.8KV TRANSFORMER CK
FDNS	02ALL	0 11G	ASGL_2010_011	FROM->TO	'Hansford County Switch Station - SPEARMAN INTERCH	160	0.42929	127.3345 'HITCHLAND INTERCHANGE (H TP80148301) 230/115/13.2KV TR
FDNS	02ALL	0 11G	ASGL_2010_011	FROM->TO	'HITCHLAND INTERCHANGE (H TP80148301) 230/115/'	250	0.59615	96.9 'Hitchland Interchange 345/0.575KV TRANSFORMER CKT 1'
FDNS	02ALL	0 11G	ASGL_2010_011	FROM->TO	'HITCHLAND INTERCHANGE (H TP80148301) 230/115/'	250	0.59615	95.5 'Hitchland Interchange (PRO G2218-01) 345/115/13.8KV TRANSFOF
FDNS	02ALL	0 11G	ASGL_2010_011	FROM->TO	'HITCHLAND INTERCHANGE (H TP80148301) 230/115/'	250	0.59615	95.2 'G08-47 345.00 345/34.5KV TRANSFORMER CKT 1'
FDNS	02ALL	0 11G	ASGL_2010_011	FROM->TO	'HITCHLAND INTERCHANGE (H TP80148301) 230/115/'	250	0.59615	95.8 'G10-01 345.00 345/34.5KV TRANSFORMER CKT 1'
FDNS	02ALL	0 11G	ASGL_2010_011	FROM->TO	'HITCHLAND INTERCHANGE (H TP80148301) 230/115/'	250	0.59615	98.7 'G06-49 345.00 345/34.5KV TRANSFORMER CKT 1'
FDNS	02ALL	2 11G	ASGL_2010_011	FROM->TO	'HITCHLAND INTERCHANGE (H TP80148301) 230/115/'	250	0.60127	98.1 'BASE CASE'
FDNS	02ALL	2 11G	ASGL_2010_011	FROM->TO	'HITCHLAND INTERCHANGE (H TP80148301) 230/115/'	250	0.60127	99 'BASE CASE'
FDNS	02ALL	2 11G	ASGL_2010_011	FROM->TO	'HITCHLAND INTERCHANGE (H TP80148301) 230/115/'	250	0.60447	107.5071 'LAWTON EASTSIDE - OKLAUNION 345KV CKT 1'
FDNS	02ALL	2 11G	ASGL_2010_011	FROM->TO	'HITCHLAND INTERCHANGE (H TP80148301) 230/115/'	250	0.60447	107.9185 'LAWTON EASTSIDE - OKLAUNION 345KV CKT 1'
FDNS	02ALL	2 11G	ASGL_2010_011	FROM->TO	'HITCHLAND INTERCHANGE (H TP80148301) 230/115/'	250	0.60447	103.6773 'G05-15T 345.00 - OKLAUNION 345KV CKT 1'
FDNS	02ALL	2 11G	ASGL_2010_011	FROM->TO	'HITCHLAND INTERCHANGE (H TP80148301) 230/115/'	250	0.60447	104.4105 'G05-15T 345.00 - OKLAUNION 345KV CKT 1'
FDNS	02ALL	2 11G	ASGL_2010_011	FROM->TO	'HITCHLAND INTERCHANGE (H TP80148301) 230/115/'	250	0.60127	96.6 'OKLAUN - OKLAUNION 345KV CKT 1'
FDNS	02ALL	2 11G	ASGL_2010_011	FROM->TO	'HITCHLAND INTERCHANGE (H TP80148301) 230/115/'	250	0.6021	99.8 'CLINTON JUNCTION - ELK CITY 138KV CKT 1'
FDNS	02ALL	2 11G	ASGL_2010_011	FROM->TO	'HITCHLAND INTERCHANGE (H TP80148301) 230/115/'	250	0.6021	100.6499 'CLINTON JUNCTION - ELK CITY 138KV CKT 1'
FDNS	02ALL	2 11G	ASGL_2010_011	FROM->TO	'HITCHLAND INTERCHANGE (H TP80148301) 230/115/'	250	0.60177	100.3615 'SPP-SWPS-T54'
FDNS	02ALL	2 11G	ASGL_2010_011	FROM->TO	'HITCHLAND INTERCHANGE (H TP80148301) 230/115/'	250	0.60187	100.2837 'SPP-SWPS-V02'
FDNS	02ALL	2 11G	ASGL_2010_011	FROM->TO	'HITCHLAND INTERCHANGE (H TP80148301) 230/115/'	250	0.60187	101.275 'SPP-SWPS-V02'
FDNS	02ALL	2 11G	ASGL_2010_011	FROM->TO	'HITCHLAND INTERCHANGE (H TP80148301) 230/115/'	250	0.60127	99.7 'GEN335831 1-RIVERBEND UNIT#1'
FDNS	02ALL	2 11G	ASGL_2010_011	FROM->TO	'HITCHLAND INTERCHANGE (H TP80148301) 230/115/'	250	0.60127	100.5516 'GEN335831 1-RIVERBEND UNIT#1'
FDNS	02ALL	2 11G	ASGL_2010_011	FROM->TO	'HITCHLAND INTERCHANGE (H TP80148301) 230/115/'	250	0.60127	100.2099 'GEN336821 1-GRAND GULF UNIT'
FDNS	02ALL	2 11G	ASGL_2010_011	FROM->TO	'HITCHLAND INTERCHANGE (H TP80148301) 230/115/'	250	0.60127	101.0133 'GEN336821 1-GRAND GULF UNIT'
FDNS	02ALL	2 11G	ASGL_2010_011	FROM->TO	'HITCHLAND INTERCHANGE (H TP80148301) 230/115/'	250	0.60127	99.3 'GEN337041 1-GERALD ANDRUS'
FDNS	02ALL	2 11G	ASGL_2010_011	FROM->TO	'HITCHLAND INTERCHANGE (H TP80148301) 230/115/'	250	0.60127	99.4 'GEN337652 1-WHITE BLUFF UNIT #1'
FDNS	02ALL	2 11G	ASGL_2010_011	FROM->TO	'HITCHLAND INTERCHANGE (H TP80148301) 230/115/'	250	0.60127	100.2044 'GEN337652 1-WHITE BLUFF UNIT #1'
FDNS	02ALL	2 11G	ASGL_2010_011	FROM->TO	'HITCHLAND INTERCHANGE (H TP80148301) 230/115/'	250	0.60127	99.3 'GEN337653 1-WHITE BLUFF UNIT #2'
FDNS	02ALL	2 11G	ASGL_2010_011	FROM->TO	'HITCHLAND INTERCHANGE (H TP80148301) 230/115/'	250	0.60127	99.4 'GEN337910 1-ARKANSAS NUCLEAR ONE UNIT #1'
FDNS	02ALL	2 11G	ASGL_2010_011	FROM->TO	'HITCHLAND INTERCHANGE (H TP80148301) 230/115/'	250	0.60127	100.2423 'GEN337910 1-ARKANSAS NUCLEAR ONE UNIT #1'
FDNS	02ALL	2 11G	ASGL_2010_011	FROM->TO	'HITCHLAND INTERCHANGE (H TP80148301) 230/115/'	250	0.60127	99.7 'GEN337911 1-ARKANSAS NUCLEAR ONE UNIT #2'
FDNS	02ALL	2 11G	ASGL_2010_011	FROM->TO	'HITCHLAND INTERCHANGE (H TP80148301) 230/115/'	250	0.60127	100.4834 'GEN337911 1-ARKANSAS NUCLEAR ONE UNIT #2'
FDNS	02ALL	2 11G	ASGL_2010_011	FROM->TO	'HITCHLAND INTERCHANGE (H TP80148301) 230/115/'	250	0.60127	99.5 'GEN338143 1-INDEPENDENCE UNIT #1'
FDNS	02ALL	2 11G	ASGL_2010_011	FROM->TO	'HITCHLAND INTERCHANGE (H TP80148301) 230/115/'	250	0.60127	100.3436 'GEN338143 1-INDEPENDENCE UNIT #1'
FDNS	02ALL	2 11G	ASGL_2010_011	FROM->TO	'HITCHLAND INTERCHANGE (H TP80148301) 230/115/'	250	0.60127	99.5 'GEN338146 1-INDEPENDENCE UNIT #2'
FDNS	02ALL	2 11G	ASGL_2010_011	FROM->TO	'HITCHLAND INTERCHANGE (H TP80148301) 230/115/'	250	0.60127	100.3431 'GEN338146 1-INDEPENDENCE UNIT #2'
FDNS	02ALL	2 11G	ASGL_2010_011	FROM->TO	'HITCHLAND INTERCHANGE (H TP80148301) 230/115/'	250	0.60127	99.4 'GEN338189 1-LS POWER OSCEOLA UNIT G1'
FDNS	02ALL	2 11G	ASGL_2010_011	FROM->TO	'HITCHLAND INTERCHANGE (H TP80148301) 230/115/'	250	0.60127	100.2337 'GEN338189 1-LS POWER OSCEOLA UNIT G1'
FDNS	02ALL	2 11G	ASGL_2010_011	FROM->TO	'HITCHLAND INTERCHANGE (H TP80148301) 230/115/'	250	0.60127	95.7 'GEN523087 1-Tri County REC-Texas County Interchange'
FDNS	02ALL	2 11G	ASGL_2010_011	FROM->TO	'HITCHLAND INTERCHANGE (H TP80148301) 230/115/'	250	0.60127	96.6 'GEN523087 1-Tri County REC-Texas County Interchange'
FDNS	02ALL	2 11G	ASGL_2010_011	FROM->TO	'HITCHLAND INTERCHANGE (H TP80148301) 230/115/'	250	0.60127	101.065 'GEN523103 1-NOBLE_WND 3115.00'
FDNS	02ALL	2 11G	ASGL_2010_011	FROM->TO	'HITCHLAND INTERCHANGE (H TP80148301) 230/115/'	250	0.60127	102.4301 'GEN523103 1-NOBLE_WND 3115.00'
FDNS	02ALL	2 11G	ASGL_2010_011	FROM->TO	'HITCHLAND INTERCHANGE (H TP80148301) 230/115/'	250	0.60127	95.1 'GEN523160 1-DWS_FRISCO 3115.00'
FDNS	02ALL	2 11G	ASGL_2010_011	FROM->TO	'HITCHLAND INTERCHANGE (H TP80148301) 230/115/'	250	0.60127	96 'GEN523277 1-VALERO SUB'
FDNS	02ALL	2 11G	ASGL_2010_011	FROM->TO	'HITCHLAND INTERCHANGE (H TP80148301) 230/115/'	250	0.60127	96.9 'GEN523277 1-VALERO SUB'
FDNS	02ALL	2 11G	ASGL_2010_011	FROM->TO	'HITCHLAND INTERCHANGE (H TP80148301) 230/115/'	250	0.60127	95.8 'GEN523926 1-MAJESTC_WND3115.00'
FDNS	02ALL	2 11G	ASGL_2010_011	FROM->TO	'HITCHLAND INTERCHANGE (H TP80148301) 230/115/'	250	0.60127	96 'GEN527161 1-MUSTANG GEN #1'
FDNS	02ALL	2 11G	ASGL_2010_011	FROM->TO	'HITCHLAND INTERCHANGE (H TP80148301) 230/115/'	250	0.60127	97 'GEN527161 1-MUSTANG GEN #1'
FDNS	02ALL	2 11G	ASGL_2010_011	FROM->TO	'HITCHLAND INTERCHANGE (H TP80148301) 230/115/'	250	0.60127	96 'GEN527162 1-MUSTANG GEN #2'
FDNS	02ALL	2 11G	ASGL_2010_011	FROM->TO	'HITCHLAND INTERCHANGE (H TP80148301) 230/115/'	250	0.60127	97 'GEN527162 1-MUSTANG GEN #2'
FDNS	02ALL	2 11G	ASGL_2010_011	FROM->TO	'HITCHLAND INTERCHANGE (H TP80148301) 230/115/'	250	0.60127	95.9 'GEN527163 1-MUSTANG GEN #3 22 KV'
FDNS	02ALL	2 11G	ASGL_2010_011	FROM->TO	'HITCHLAND INTERCHANGE (H TP80148301) 230/115/'	250	0.60127	96.9 'GEN527163 1-MUSTANG GEN #3 22 KV'
FDNS	02ALL	2 11G	ASGL_2010_011	FROM->TO	'HITCHLAND INTERCHANGE (H TP80148301) 230/115/'	250	0.60127	96 'GEN527164 1-MUSTANG GEN #4 22 KV'
FDNS	02ALL	2 11G	ASGL_2010_011	FROM->TO	'HITCHLAND INTERCHANGE (H TP80148301) 230/115/'	250	0.60127	97 'GEN527164 1-MUSTANG GEN #4 22 KV'
FDNS	02ALL	2 11G	ASGL_2010_011	FROM->TO	'HITCHLAND INTERCHANGE (H TP80148301) 230/115/'	250	0.60127	96 'GEN527165 1-Mustang Gen #5'
FDNS	02ALL	2 11G	ASGL_2010_011	FROM->TO	'HITCHLAND INTERCHANGE (H TP80148301) 230/115/'	250	0.60127	97 'GEN527165 1-Mustang Gen #5'
FDNS	02ALL	2 11G	ASGL_2010_011	FROM->TO	'HITCHLAND INTERCHANGE (H TP80148301) 230/115/'	250	0.60127	96 'GEN527901 1-HOBBS PLANT #1 (CT)'
FDNS	02ALL	2 11G	ASGL_2010_011	FROM->TO	'HITCHLAND INTERCHANGE (H TP80148301) 230/115/'	250	0.60127	97 'GEN527901 1-HOBBS PLANT #1 (CT)'
FDNS	02ALL	2 11G	ASGL_2010_011	FROM->TO	'HITCHLAND INTERCHANGE (H TP80148301) 230/115/'	250	0.60127	96 'GEN527902 1-HOBBS PLANT #2 (CT)'
FDNS	02ALL	2 11G	ASGL_2010_011	FROM->TO	'HITCHLAND INTERCHANGE (H TP80148301) 230/115/'	250	0.60127	97 'GEN527902 1-HOBBS PLANT #2 (CT)'
FDNS	02ALL	2 11G	ASGL_2010_011	FROM->TO	'HITCHLAND INTERCHANGE (H TP80148301) 230/115/'	250	0.60127	100.3199 'GEN531447 1-HOLCOMB GENERATOR'
FDNS	02ALL	2 11G	ASGL_2010_011	FROM->TO	'HITCHLAND INTERCHANGE (H TP80148301) 230/115/'	250	0.60127	101.3491 'GEN531447 1-HOLCOMB GENERATOR'
FDNS	02ALL	2 11G	ASGL_2010_011	FROM->TO	'HITCHLAND INTERCHANGE (H TP80148301) 230/115/'	250	0.60127	99.3 'GEN532651 1-JEFFREY ENERGY CENTER UNIT 1'
FDNS	02ALL	2 11G	ASGL_2010_011	FROM->TO	'HITCHLAND INTERCHANGE (H TP80148301) 230/115/'	250	0.60127	99.3 'GEN532652 1-JEFFREY ENERGY CENTER UNIT 2'
FDNS	02ALL	2 11G	ASGL_2010_011	FROM->TO	'HITCHLAND INTERCHANGE (H TP80148301) 230/115/'	250	0.60127	100.9629 'GEN532751 1-WOLF CREEK GENERATING STATION UNIT 1'
FDNS	02ALL	2 11G	ASGL_2010_011	FROM->TO	'HITCHLAND INTERCHANGE (H TP80148301) 230/115/'	250	0.60127	101.7581 'GEN532751 1-WOLF CREEK GENERATING STATION UNIT 1'

SOLUTION GROUP	SCENARI	SEASON	SOURCE	DIRECTION	MONITORED ELEMENT	COMMON NAME	RATEB	TDF	TC%	LOAD	CONTINGENCY	NAME
FDNS	02ALL	2 11G	ASGL_2010_011	'FROM->TO'	'HITCHLAND INTERCHANGE (H TP80148301) 230/115/'		250	0.60127	99.6	'GEN542955	1-LACYGNE UNIT #1'	
FDNS	02ALL	2 11G	ASGL_2010_011	'FROM->TO'	'HITCHLAND INTERCHANGE (H TP80148301) 230/115/'		250	0.60127	100.4352	'GEN542955	1-LACYGNE UNIT #1'	
FDNS	02ALL	2 11G	ASGL_2010_011	'FROM->TO'	'HITCHLAND INTERCHANGE (H TP80148301) 230/115/'		250	0.60127	99.4	'GEN542956	2-LACYGNE UNIT #2'	
FDNS	02ALL	2 11G	ASGL_2010_011	'FROM->TO'	'HITCHLAND INTERCHANGE (H TP80148301) 230/115/'		250	0.60127	100.3283	'GEN542956	2-LACYGNE UNIT #2'	
FDNS	02ALL	2 11G	ASGL_2010_011	'FROM->TO'	'HITCHLAND INTERCHANGE (H TP80148301) 230/115/'		250	0.60127	99.7	'GEN542957	1-IATAN UNIT #1'	
FDNS	02ALL	2 11G	ASGL_2010_011	'FROM->TO'	'HITCHLAND INTERCHANGE (H TP80148301) 230/115/'		250	0.60127	100.531	'GEN542957	1-IATAN UNIT #1'	
FDNS	02ALL	2 11G	ASGL_2010_011	'FROM->TO'	'HITCHLAND INTERCHANGE (H TP80148301) 230/115/'		250	0.60127	100	'GEN542962	2-IATAN UNIT #2'	
FDNS	02ALL	2 11G	ASGL_2010_011	'FROM->TO'	'HITCHLAND INTERCHANGE (H TP80148301) 230/115/'		250	0.60127	100.8191	'GEN542962	2-IATAN UNIT #2'	
FDNS	02ALL	2 11G	ASGL_2010_011	'FROM->TO'	'HITCHLAND INTERCHANGE (H TP80148301) 230/115/'		250	0.60127	100.5611	'GEN560121	1-G08-47 0.5750'	
FDNS	02ALL	2 11G	ASGL_2010_011	'FROM->TO'	'HITCHLAND INTERCHANGE (H TP80148301) 230/115/'		250	0.60127	101.5523	'GEN560121	1-G08-47 0.5750'	
FDNS	02ALL	2 11G	ASGL_2010_011	'FROM->TO'	'HITCHLAND INTERCHANGE (H TP80148301) 230/115/'		250	0.60127	101.2415	'GEN560133	1-G08-110 0.5750'	
FDNS	02ALL	2 11G	ASGL_2010_011	'FROM->TO'	'HITCHLAND INTERCHANGE (H TP80148301) 230/115/'		250	0.60127	102.1668	'GEN560133	1-G08-110 0.5750'	
FDNS	02ALL	2 11G	ASGL_2010_011	'FROM->TO'	'HITCHLAND INTERCHANGE (H TP80148301) 230/115/'		250	0.60127	96	'GEN560166	1-G07-48 0.6900'	
FDNS	02ALL	2 11G	ASGL_2010_011	'FROM->TO'	'HITCHLAND INTERCHANGE (H TP80148301) 230/115/'		250	0.60127	97	'GEN560166	1-G07-48 0.6900'	
FDNS	02ALL	2 11G	ASGL_2010_011	'FROM->TO'	'HITCHLAND INTERCHANGE (H TP80148301) 230/115/'		250	0.60127	100.3574	'GEN560256	1-G10-14-1 0.6900'	
FDNS	02ALL	2 11G	ASGL_2010_011	'FROM->TO'	'HITCHLAND INTERCHANGE (H TP80148301) 230/115/'		250	0.60127	101.6946	'GEN560256	1-G10-14-1 0.6900'	
FDNS	02ALL	2 11G	ASGL_2010_011	'FROM->TO'	'HITCHLAND INTERCHANGE (H TP80148301) 230/115/'		250	0.60127	100.4101	'GEN560257	1-G10-14-2 0.6900'	
FDNS	02ALL	2 11G	ASGL_2010_011	'FROM->TO'	'HITCHLAND INTERCHANGE (H TP80148301) 230/115/'		250	0.60127	101.7555	'GEN560257	1-G10-14-2 0.6900'	
FDNS	02ALL	2 11G	ASGL_2010_011	'FROM->TO'	'HITCHLAND INTERCHANGE (H TP80148301) 230/115/'		250	0.60127	99.5	'GEN560286	1-G10-01-1WTG 0.6900'	
FDNS	02ALL	2 11G	ASGL_2010_011	'FROM->TO'	'HITCHLAND INTERCHANGE (H TP80148301) 230/115/'		250	0.60127	100.5453	'GEN560286	1-G10-01-1WTG 0.6900'	
FDNS	02ALL	2 11G	ASGL_2010_011	'FROM->TO'	'HITCHLAND INTERCHANGE (H TP80148301) 230/115/'		250	0.60127	99.5	'GEN560287	1-G10-01-2WTG 0.6900'	
FDNS	02ALL	2 11G	ASGL_2010_011	'FROM->TO'	'HITCHLAND INTERCHANGE (H TP80148301) 230/115/'		250	0.60127	100.5453	'GEN560287	1-G10-01-2WTG 0.6900'	
FDNS	02ALL	2 11G	ASGL_2010_011	'FROM->TO'	'HITCHLAND INTERCHANGE (H TP80148301) 230/115/'		250	0.60127	96.2	'GEN560570	1-G06-39 0.6900'	
FDNS	02ALL	2 11G	ASGL_2010_011	'FROM->TO'	'HITCHLAND INTERCHANGE (H TP80148301) 230/115/'		250	0.60127	97.2	'GEN560570	1-G06-39 0.6900'	
FDNS	02ALL	2 11G	ASGL_2010_011	'FROM->TO'	'HITCHLAND INTERCHANGE (H TP80148301) 230/115/'		250	0.60127	99.7	'GEN560585	1-G06-44-2 0.6000'	
FDNS	02ALL	2 11G	ASGL_2010_011	'FROM->TO'	'HITCHLAND INTERCHANGE (H TP80148301) 230/115/'		250	0.60127	100.8672	'GEN560585	1-G06-44-2 0.6000'	
FDNS	02ALL	2 11G	ASGL_2010_011	'FROM->TO'	'HITCHLAND INTERCHANGE (H TP80148301) 230/115/'		250	0.60127	100.3299	'GEN560586	1-G06-44-3 0.6000'	
FDNS	02ALL	2 11G	ASGL_2010_011	'FROM->TO'	'HITCHLAND INTERCHANGE (H TP80148301) 230/115/'		250	0.60127	101.5961	'GEN560586	1-G06-44-3 0.6000'	
FDNS	02ALL	2 11G	ASGL_2010_011	'FROM->TO'	'HITCHLAND INTERCHANGE (H TP80148301) 230/115/'		250	0.60127	101.6196	'GEN560598	1-G06-49 0.6000'	
FDNS	02ALL	2 11G	ASGL_2010_011	'FROM->TO'	'HITCHLAND INTERCHANGE (H TP80148301) 230/115/'		250	0.60127	102.961	'GEN560598	1-G06-49 0.6000'	
FDNS	02ALL	2 11G	ASGL_2010_011	'FROM->TO'	'HITCHLAND INTERCHANGE (H TP80148301) 230/115/'		250	0.60127	99.8	'GEN640009	1-COOPER NUCLEAR STATION'	
FDNS	02ALL	2 11G	ASGL_2010_011	'FROM->TO'	'HITCHLAND INTERCHANGE (H TP80148301) 230/115/'		250	0.60127	100.7358	'GEN640009	1-COOPER NUCLEAR STATION'	
FDNS	02ALL	2 11G	ASGL_2010_011	'FROM->TO'	'HITCHLAND INTERCHANGE (H TP80148301) 230/115/'		250	0.60127	99.4	'GEN640010	1-GERALD GENTLEMAN STATION UNIT 1'	
FDNS	02ALL	2 11G	ASGL_2010_011	'FROM->TO'	'HITCHLAND INTERCHANGE (H TP80148301) 230/115/'		250	0.60127	100.3266	'GEN640010	1-GERALD GENTLEMAN STATION UNIT 1'	
FDNS	02ALL	2 11G	ASGL_2010_011	'FROM->TO'	'HITCHLAND INTERCHANGE (H TP80148301) 230/115/'		250	0.60127	99.4	'GEN645011	1-NEBRASKA CITY 1'	
FDNS	02ALL	2 11G	ASGL_2010_011	'FROM->TO'	'HITCHLAND INTERCHANGE (H TP80148301) 230/115/'		250	0.60127	100.3158	'GEN645011	1-NEBRASKA CITY 1'	
FDNS	02ALL	2 11G	ASGL_2010_011	'FROM->TO'	'HITCHLAND INTERCHANGE (H TP80148301) 230/115/'		250	0.60127	99.6	'GEN645012	2-NEBRASKA CITY 2'	
FDNS	02ALL	2 11G	ASGL_2010_011	'FROM->TO'	'HITCHLAND INTERCHANGE (H TP80148301) 230/115/'		250	0.60127	100.5329	'GEN645012	2-NEBRASKA CITY 2'	
FNSL	02ALL	2 11G	ASGL_2010_011	'FROM->TO'	'HITCHLAND INTERCHANGE (H TP80148301) 230/115/'		250	0.60127	100	'GEN336153	1-WATERFORD UNIT#3'	
FNSL	02ALL	2 11G	ASGL_2010_011	'FROM->TO'	'HITCHLAND INTERCHANGE (H TP80148301) 230/115/'		250	0.60127	100.7611	'GEN336153	1-WATERFORD UNIT#3'	
FNSL-Itera	02ALL	2 11G	ASGL_2010_011		Non Converged		0	0.27726	9999	'DBL-G0847-WO'		
FDNS	02ALL	2 11G	ASGL_2010_011	'FROM->TO'	'HITCHLAND INTERCHANGE (H TP80148301) 230/115/'		250	0.60626	109.5093	'ELK CITY 230KV - SWEETWT6	230.00 230KV CKT 1'	
FDNS	02ALL	2 11G	ASGL_2010_011	'FROM->TO'	'HITCHLAND INTERCHANGE (H TP80148301) 230/115/'		250	0.60626	110.2039	'ELK CITY 230KV - SWEETWT6	230.00 230KV CKT 1'	
FDNS	02ALL	2 11G	ASGL_2010_011	'FROM->TO'	'HITCHLAND INTERCHANGE (H TP80148301) 230/115/'		250	0.60655	106.4911	'STLN-DEMARC6230.00 - SWEETWT6	230.00 230KV CKT 1'	
FDNS	02ALL	2 11G	ASGL_2010_011	'FROM->TO'	'HITCHLAND INTERCHANGE (H TP80148301) 230/115/'		250	0.60655	107.274	'STLN-DEMARC6230.00 - SWEETWT6	230.00 230KV CKT 1'	
FDNS	02ALL	2 11G	ASGL_2010_011	'FROM->TO'	'HITCHLAND INTERCHANGE (H TP80148301) 230/115/'		250	0.60222	99.7	'CHILDRESS - LAKE PAULINE	138KV CKT 1'	
FDNS	02ALL	2 11G	ASGL_2010_011	'FROM->TO'	'HITCHLAND INTERCHANGE (H TP80148301) 230/115/'		250	0.60222	100.6116	'CHILDRESS - LAKE PAULINE	138KV CKT 1'	
FDNS	02ALL	2 11G	ASGL_2010_011	'FROM->TO'	'HITCHLAND INTERCHANGE (H TP80148301) 230/115/'		250	0.60086	96.7	'FPL SWITCH - WOODWARD	138KV CKT 1'	
FDNS	02ALL	2 11G	ASGL_2010_011	'FROM->TO'	'HITCHLAND INTERCHANGE (H TP80148301) 230/115/'		250	0.60086	97.5	'FPL SWITCH - WOODWARD	138KV CKT 1'	
FDNS	02ALL	2 11G	ASGL_2010_011	'FROM->TO'	'HITCHLAND INTERCHANGE (H TP80148301) 230/115/'		250	0.59996	95.4	'2008-047 TAP345.00 - WWRDEHV7	345.00 345KV CKT 1'	
FDNS	02ALL	2 11G	ASGL_2010_011	'FROM->TO'	'HITCHLAND INTERCHANGE (H TP80148301) 230/115/'		250	0.59996	95.4	'2008-047 TAP345.00 - WWRDEHV7	345.00 345KV CKT 2'	
FDNS	02ALL	2 11G	ASGL_2010_011	'FROM->TO'	'HITCHLAND INTERCHANGE (H TP80148301) 230/115/'		250	0.60087	96.6	'FPL SWITCH - MOORELAND	138KV CKT 1'	
FDNS	02ALL	2 11G	ASGL_2010_011	'FROM->TO'	'HITCHLAND INTERCHANGE (H TP80148301) 230/115/'		250	0.60087	97.4	'FPL SWITCH - MOORELAND	138KV CKT 1'	
FDNS	02ALL	2 11G	ASGL_2010_011	'FROM->TO'	'HITCHLAND INTERCHANGE (H TP80148301) 230/115/'		250	0.60127	101.1701	'HOVEY TAP - TRI COUNTY REC-HOVEY SUB	69KV CKT 1'	
FDNS	02ALL	2 11G	ASGL_2010_011	'FROM->TO'	'HITCHLAND INTERCHANGE (H TP80148301) 230/115/'		250	0.60127	102.1215	'HOVEY TAP - TRI COUNTY REC-HOVEY SUB	69KV CKT 1'	
FDNS	02ALL	2 11G	ASGL_2010_011	'FROM->TO'	'HITCHLAND INTERCHANGE (H TP80148301) 230/115/'		250	0.60127	100.22	'ELKHART TAP - EVA REGULATOR	69KV CKT 1'	
FDNS	02ALL	2 11G	ASGL_2010_011	'FROM->TO'	'HITCHLAND INTERCHANGE (H TP80148301) 230/115/'		250	0.60127	99.3	'EVA REGULATOR - THOMPSON SUB	69KV CKT 1'	
FDNS	02ALL	2 11G	ASGL_2010_011	'FROM->TO'	'HITCHLAND INTERCHANGE (H TP80148301) 230/115/'		250	0.60127	100.2379	'EVA REGULATOR - THOMPSON SUB	69KV CKT 1'	
FDNS	02ALL	2 11G	ASGL_2010_011	'FROM->TO'	'HITCHLAND INTERCHANGE (H TP80148301) 230/115/'		250	0.60127	101.1758	'HOVEY TAP - THOMPSON SUB	69KV CKT 1'	
FDNS	02ALL	2 11G	ASGL_2010_011	'FROM->TO'	'HITCHLAND INTERCHANGE (H TP80148301) 230/115/'		250	0.60127	102.1352	'HOVEY TAP - THOMPSON SUB	69KV CKT 1'	
FDNS	02ALL	2 11G	ASGL_2010_011	'FROM->TO'	'HITCHLAND INTERCHANGE (H TP80148301) 230/115/'		250	0.52903	95.7	'HITCHLAND INTERCHANGE - TEXAS COUNTY INTERCHANGE 1		
FDNS	02ALL	2 11G	ASGL_2010_011	'FROM->TO'	'HITCHLAND INTERCHANGE (H TP80148301) 230/115/'		250	0.57518	96.8	'HITCHLAND INTERCHANGE - TEXAS COUNTY INTERCHANGE 1		
FDNS	02ALL	2 11G	ASGL_2010_011	'FROM->TO'	'HITCHLAND INTERCHANGE (H TP80148301) 230/115/'		250	0.60127	99.7	'TEXAS COUNTY INTERCHANGE - Tri County REC-Whiting Sub 11:		
FDNS	02ALL	2 11G	ASGL_2010_011	'FROM->TO'	'HITCHLAND INTERCHANGE (H TP80148301) 230/115/'		250	0.60127	100.6625	'TEXAS COUNTY INTERCHANGE - Tri County REC-Whiting Sub 11:		
FDNS	02ALL	2 11G	ASGL_2010_011	'FROM->TO'	'HITCHLAND INTERCHANGE (H TP80148301) 230/115/'		250	0.69233	109.4311	'TEXAS COUNTY INTERCHANGE - TRI COUNTY REC-GUYMON 1		
FDNS	02ALL	2 11G	ASGL_2010_011	'FROM->TO'	'HITCHLAND INTERCHANGE (H TP80148301) 230/115/'		250	0.69233	110.8998	'TEXAS COUNTY INTERCHANGE - TRI COUNTY REC-GUYMON 1		
FDNS	02ALL	2 11G	ASGL_2010_011	'FROM->TO'	'HITCHLAND INTERCHANGE (H TP80148301) 230/115/'		250	0.66502	109.075	'DWS_FRISCO 3115.00 - HITCHLAND INTERCHANGE	115KV CKT	

SOLUTION GROUP	SCENARI	SEASON	SOURCE	DIRECTION	MONITORED ELEMENT COMMON NAME	RATEB	TDF	TC%	LOAD	CONTINGENCY	NAME
FDNS	02ALL	2 11G	ASGL_2010_011	'FROM->TO'	'HITCHLAND INTERCHANGE (H TP80148301) 230/115/'	250	0.66502	110.6923	'DWS_FRISCO 3115.00 - HITCHLAND INTERCHANGE 115KV CKT		
FDNS	02ALL	2 11G	ASGL_2010_011	'FROM->TO'	'HITCHLAND INTERCHANGE (H TP80148301) 230/115/'	250	0.69276	100.3287	'HITCHLAND INTERCHANGE - Hansford County Switch Station 1151		
FDNS	02ALL	2 11G	ASGL_2010_011	'FROM->TO'	'HITCHLAND INTERCHANGE (H TP80148301) 230/115/'	250	0.69276	101.8273	'HITCHLAND INTERCHANGE - Hansford County Switch Station 1151		
FDNS	02ALL	2 11G	ASGL_2010_011	'FROM->TO'	'HITCHLAND INTERCHANGE (H TP80148301) 230/115/'	250	0.5831	95.6	'Hitchland Interchange 345/230KV TRANSFORMER CKT 2'		
FDNS	02ALL	2 11G	ASGL_2010_011	'FROM->TO'	'HITCHLAND INTERCHANGE (H TP80148301) 230/115/'	250	0.5831	96.3	'Hitchland Interchange 345/230KV TRANSFORMER CKT 2'		
FDNS	02ALL	2 11G	ASGL_2010_011	'FROM->TO'	'HITCHLAND INTERCHANGE (H TP80148301) 230/115/'	250	0.67145	102.2799	'HITCHLAND INTERCHANGE - OCHILTREE 6230.00 230KV CKT 1		
FDNS	02ALL	2 11G	ASGL_2010_011	'FROM->TO'	'HITCHLAND INTERCHANGE (H TP80148301) 230/115/'	250	0.67145	103.7996	'HITCHLAND INTERCHANGE - OCHILTREE 6230.00 230KV CKT 1		
FDNS	02ALL	2 11G	ASGL_2010_011	'FROM->TO'	'HITCHLAND INTERCHANGE (H TP80148301) 230/115/'	250	0.59991	95.2	'BORDER 7345.00 - Hitchland Interchange 345KV CKT 1'		
FDNS	02ALL	2 11G	ASGL_2010_011	'FROM->TO'	'HITCHLAND INTERCHANGE (H TP80148301) 230/115/'	250	0.59991	95.7	'BORDER 7345.00 - Hitchland Interchange 345KV CKT 1'		
FDNS	02ALL	2 11G	ASGL_2010_011	'FROM->TO'	'HITCHLAND INTERCHANGE (H TP80148301) 230/115/'	250	0.59991	95.2	'BORDER 7345.00 - Hitchland Interchange 345KV CKT 2'		
FDNS	02ALL	2 11G	ASGL_2010_011	'FROM->TO'	'HITCHLAND INTERCHANGE (H TP80148301) 230/115/'	250	0.59991	95.7	'BORDER 7345.00 - Hitchland Interchange 345KV CKT 2'		
FDNS	02ALL	2 11G	ASGL_2010_011	'FROM->TO'	'HITCHLAND INTERCHANGE (H TP80148301) 230/115/'	250	0.59716	95.9	'Hitchland Interchange - STEVENSCO 345.00 345KV CKT 1'		
FDNS	02ALL	2 11G	ASGL_2010_011	'FROM->TO'	'HITCHLAND INTERCHANGE (H TP80148301) 230/115/'	250	0.59716	96.5	'Hitchland Interchange - STEVENSCO 345.00 345KV CKT 1'		
FDNS	02ALL	2 11G	ASGL_2010_011	'FROM->TO'	'HITCHLAND INTERCHANGE (H TP80148301) 230/115/'	250	0.60127	108.4	'G10-14 345.00 - Hitchland Interchange 345KV CKT 1'		
FDNS	02ALL	2 11G	ASGL_2010_011	'FROM->TO'	'HITCHLAND INTERCHANGE (H TP80148301) 230/115/'	250	0.60038	111.3481	'G05-17T 345.00 - Hitchland Interchange 345KV CKT 1'		
FDNS	02ALL	2 11G	ASGL_2010_011	'FROM->TO'	'HITCHLAND INTERCHANGE (H TP80148301) 230/115/'	250	0.60038	112.5155	'G05-17T 345.00 - Hitchland Interchange 345KV CKT 1'		
FDNS	02ALL	2 11G	ASGL_2010_011	'FROM->TO'	'HITCHLAND INTERCHANGE (H TP80148301) 230/115/'	250	0.59986	96.4	'2008-047 TAP345.00 - Hitchland Interchange 345KV CKT 1'		
FDNS	02ALL	2 11G	ASGL_2010_011	'FROM->TO'	'HITCHLAND INTERCHANGE (H TP80148301) 230/115/'	250	0.59986	97.1	'2008-047 TAP345.00 - Hitchland Interchange 345KV CKT 1'		
FDNS	02ALL	2 11G	ASGL_2010_011	'FROM->TO'	'HITCHLAND INTERCHANGE (H TP80148301) 230/115/'	250	0.59986	96.4	'2008-047 TAP345.00 - Hitchland Interchange 345KV CKT 2'		
FDNS	02ALL	2 11G	ASGL_2010_011	'FROM->TO'	'HITCHLAND INTERCHANGE (H TP80148301) 230/115/'	250	0.59986	97.1	'2008-047 TAP345.00 - Hitchland Interchange 345KV CKT 2'		
FDNS	02ALL	2 11G	ASGL_2010_011	'FROM->TO'	'HITCHLAND INTERCHANGE (H TP80148301) 230/115/'	250	0.69233	108.5038	'TRI COUNTY REC-COLE - TRI COUNTY REC-GUYMON 115KV CKT 1'		
FDNS	02ALL	2 11G	ASGL_2010_011	'FROM->TO'	'HITCHLAND INTERCHANGE (H TP80148301) 230/115/'	250	0.69233	109.946	'TRI COUNTY REC-COLE - TRI COUNTY REC-GUYMON 115KV CKT 1'		
FDNS	02ALL	2 11G	ASGL_2010_011	'FROM->TO'	'HITCHLAND INTERCHANGE (H TP80148301) 230/115/'	250	0.69233	104.0221	'OCHILTREE 3115.00 - TRI COUNTY REC-COLE 115KV CKT 1'		
FDNS	02ALL	2 11G	ASGL_2010_011	'FROM->TO'	'HITCHLAND INTERCHANGE (H TP80148301) 230/115/'	250	0.69233	105.4212	'OCHILTREE 3115.00 - TRI COUNTY REC-COLE 115KV CKT 1'		
FDNS	02ALL	2 11G	ASGL_2010_011	'FROM->TO'	'HITCHLAND INTERCHANGE (H TP80148301) 230/115/'	250	0.59311	99.5	'OCHILTREE 3115.00 - TEXAS FARMS SUB 115KV CKT 1'		
FDNS	02ALL	2 11G	ASGL_2010_011	'FROM->TO'	'HITCHLAND INTERCHANGE (H TP80148301) 230/115/'	250	0.59311	100.7134	'OCHILTREE 3115.00 - TEXAS FARMS SUB 115KV CKT 1'		
FDNS	02ALL	2 11G	ASGL_2010_011	'FROM->TO'	'HITCHLAND INTERCHANGE (H TP80148301) 230/115/'	250	0.59311	99.6	'SPEARMAN SUB - TEXAS FARMS SUB 115KV CKT 1'		
FDNS	02ALL	2 11G	ASGL_2010_011	'FROM->TO'	'HITCHLAND INTERCHANGE (H TP80148301) 230/115/'	250	0.59311	100.8207	'SPEARMAN SUB - TEXAS FARMS SUB 115KV CKT 1'		
FDNS	02ALL	2 11G	ASGL_2010_011	'FROM->TO'	'HITCHLAND INTERCHANGE (H TP80148301) 230/115/'	250	0.67145	102.3915	'OCHILTREE 6230.00 230/115KV TRANSFORMER CKT 1'		
FDNS	02ALL	2 11G	ASGL_2010_011	'FROM->TO'	'HITCHLAND INTERCHANGE (H TP80148301) 230/115/'	250	0.67145	103.9866	'OCHILTREE 6230.00 230/115KV TRANSFORMER CKT 1'		
FDNS	02ALL	2 11G	ASGL_2010_011	'FROM->TO'	'HITCHLAND INTERCHANGE (H TP80148301) 230/115/'	250	0.60127	100.2289	'OCHILTREE 3115.00 - PERRYTON INTERCHANGE 115KV CKT 1'		
FDNS	02ALL	2 11G	ASGL_2010_011	'FROM->TO'	'HITCHLAND INTERCHANGE (H TP80148301) 230/115/'	250	0.66454	114.1903	'DWS_FRISCO 3115.00 - SHERMAN COUNTY TAP 115KV CKT 1'		
FDNS	02ALL	2 11G	ASGL_2010_011	'FROM->TO'	'HITCHLAND INTERCHANGE (H TP80148301) 230/115/'	250	0.66454	115.893	'DWS_FRISCO 3115.00 - SHERMAN COUNTY TAP 115KV CKT 1'		
FDNS	02ALL	2 11G	ASGL_2010_011	'FROM->TO'	'HITCHLAND INTERCHANGE (H TP80148301) 230/115/'	250	0.60831	100	'SHERMAN COUNTY SUB - SHERMAN COUNTY TAP 115KV CKT 1'		
FDNS	02ALL	2 11G	ASGL_2010_011	'FROM->TO'	'HITCHLAND INTERCHANGE (H TP80148301) 230/115/'	250	0.60831	101.0011	'SHERMAN COUNTY SUB - SHERMAN COUNTY TAP 115KV CKT 1'		
FDNS	02ALL	2 11G	ASGL_2010_011	'FROM->TO'	'HITCHLAND INTERCHANGE (H TP80148301) 230/115/'	250	0.60812	101.0045	'DALLAM COUNTY INTERCHANGE - SHERMAN COUNTY SUB 115KV CKT 1'		
FDNS	02ALL	2 11G	ASGL_2010_011	'FROM->TO'	'HITCHLAND INTERCHANGE (H TP80148301) 230/115/'	250	0.60812	102.0293	'DALLAM COUNTY INTERCHANGE - SHERMAN COUNTY SUB 115KV CKT 1'		
FDNS	02ALL	2 11G	ASGL_2010_011	'FROM->TO'	'HITCHLAND INTERCHANGE (H TP80148301) 230/115/'	250	0.62843	104.6796	'RB-SPURLOCK3115.00 - SHERMAN COUNTY TAP 115KV CKT 1'		
FDNS	02ALL	2 11G	ASGL_2010_011	'FROM->TO'	'HITCHLAND INTERCHANGE (H TP80148301) 230/115/'	250	0.62843	105.8806	'RB-SPURLOCK3115.00 - SHERMAN COUNTY TAP 115KV CKT 1'		
FDNS	02ALL	2 11G	ASGL_2010_011	'FROM->TO'	'HITCHLAND INTERCHANGE (H TP80148301) 230/115/'	250	0.62843	104.0649	'MOORE COUNTY INTERCHANGE EAST BUS - RB-SPURLOCK31		
FDNS	02ALL	2 11G	ASGL_2010_011	'FROM->TO'	'HITCHLAND INTERCHANGE (H TP80148301) 230/115/'	250	0.62843	105.2478	'MOORE COUNTY INTERCHANGE EAST BUS - RB-SPURLOCK31		
FDNS	02ALL	2 11G	ASGL_2010_011	'FROM->TO'	'HITCHLAND INTERCHANGE (H TP80148301) 230/115/'	250	0.69077	121.9022	'Hansford County Switch Station - SPEARMAN INTERCHANGE 1151		
FDNS	02ALL	2 11G	ASGL_2010_011	'FROM->TO'	'HITCHLAND INTERCHANGE (H TP80148301) 230/115/'	250	0.69077	123.8985	'Hansford County Switch Station - SPEARMAN INTERCHANGE 1151		
FDNS	02ALL	2 11G	ASGL_2010_011	'FROM->TO'	'HITCHLAND INTERCHANGE (H TP80148301) 230/115/'	250	0.59311	100	'SPEARMAN INTERCHANGE - SPEARMAN SUB 115KV CKT 1'		
FDNS	02ALL	2 11G	ASGL_2010_011	'FROM->TO'	'HITCHLAND INTERCHANGE (H TP80148301) 230/115/'	250	0.59311	101.1982	'SPEARMAN INTERCHANGE - SPEARMAN SUB 115KV CKT 1'		
FDNS	02ALL	2 11G	ASGL_2010_011	'FROM->TO'	'HITCHLAND INTERCHANGE (H TP80148301) 230/115/'	250	0.61835	100	'PRINGLE INTERCHANGE - SPEARMAN INTERCHANGE 115KV CKT 1'		
FDNS	02ALL	2 11G	ASGL_2010_011	'FROM->TO'	'HITCHLAND INTERCHANGE (H TP80148301) 230/115/'	250	0.61835	101.0178	'PRINGLE INTERCHANGE - SPEARMAN INTERCHANGE 115KV CKT 1'		
FDNS	02ALL	2 11G	ASGL_2010_011	'FROM->TO'	'HITCHLAND INTERCHANGE (H TP80148301) 230/115/'	250	0.6115	99.3	'PRINGLE INTERCHANGE - SPEARMAN INTERCHANGE 115KV CKT 1'		
FDNS	02ALL	2 11G	ASGL_2010_011	'FROM->TO'	'HITCHLAND INTERCHANGE (H TP80148301) 230/115/'	250	0.6115	100.2365	'PRINGLE INTERCHANGE - SPEARMAN INTERCHANGE 115KV CKT 1'		
FDNS	02ALL	2 11G	ASGL_2010_011	'FROM->TO'	'HITCHLAND INTERCHANGE (H TP80148301) 230/115/'	250	0.61578	101.9045	'Harrington Station East Bus - PRINGLE INTERCHANGE 230KV CKT 1'		
FDNS	02ALL	2 11G	ASGL_2010_011	'FROM->TO'	'HITCHLAND INTERCHANGE (H TP80148301) 230/115/'	250	0.61578	102.8671	'Harrington Station East Bus - PRINGLE INTERCHANGE 230KV CKT 1'		
FDNS	02ALL	2 11G	ASGL_2010_011	'FROM->TO'	'HITCHLAND INTERCHANGE (H TP80148301) 230/115/'	250	0.60249	99.5	'BLACKHAWK STATION S. - WO_OPERATNG3115.00 115KV CKT 1'		
FDNS	02ALL	2 11G	ASGL_2010_011	'FROM->TO'	'HITCHLAND INTERCHANGE (H TP80148301) 230/115/'	250	0.60249	100.5038	'BLACKHAWK STATION S. - WO_OPERATNG3115.00 115KV CKT 1'		
FDNS	02ALL	2 11G	ASGL_2010_011	'FROM->TO'	'HITCHLAND INTERCHANGE (H TP80148301) 230/115/'	250	0.60249	99.4	'HUTCHINSON COUNTY INTERCHANGE N. - WO_OPERATNG311		
FDNS	02ALL	2 11G	ASGL_2010_011	'FROM->TO'	'HITCHLAND INTERCHANGE (H TP80148301) 230/115/'	250	0.60249	100.3298	'HUTCHINSON COUNTY INTERCHANGE N. - WO_OPERATNG311		
FDNS	02ALL	2 11G	ASGL_2010_011	'FROM->TO'	'HITCHLAND INTERCHANGE (H TP80148301) 230/115/'	250	0.60836	101.542	'G10-07T 115.00 - RIVERVIEW INTERCHANGE 115KV CKT 1'		
FDNS	02ALL	2 11G	ASGL_2010_011	'FROM->TO'	'HITCHLAND INTERCHANGE (H TP80148301) 230/115/'	250	0.60836	102.6054	'G10-07T 115.00 - RIVERVIEW INTERCHANGE 115KV CKT 1'		
FDNS	02ALL	2 11G	ASGL_2010_011	'FROM->TO'	'HITCHLAND INTERCHANGE (H TP80148301) 230/115/'	250	0.60544	99.6	'HUTCHINSON COUNTY INTERCHANGE - NICHOLS STATION 23C		
FDNS	02ALL	2 11G	ASGL_2010_011	'FROM->TO'	'HITCHLAND INTERCHANGE (H TP80148301) 230/115/'	250	0.60544	100.5554	'HUTCHINSON COUNTY INTERCHANGE - NICHOLS STATION 23C		
FDNS	02ALL	2 11G	ASGL_2010_011	'FROM->TO'	'HITCHLAND INTERCHANGE (H TP80148301) 230/115/'	250	0.60655	107.2683	'GRAPEVINE INTERCHANGE - STATELINE INTERCHANGE 230KV		
FDNS	02ALL	2 11G	ASGL_2010_011	'FROM->TO'	'HITCHLAND INTERCHANGE (H TP80148301) 230/115/'	250	0.60655	108.0319	'GRAPEVINE INTERCHANGE - STATELINE INTERCHANGE 230KV		
FDNS	02ALL	2 11G	ASGL_2010_011	'FROM->TO'	'HITCHLAND INTERCHANGE (H TP80148301) 230/115/'	250	0.60372	103.4313	'GRAPEVINE INTERCHANGE - NICHOLS STATION 230KV CKT 1'		
FDNS	02ALL	2 11G	ASGL_2010_011	'FROM->TO'	'HITCHLAND INTERCHANGE (H TP80148301) 230/115/'	250	0.60372	104.2454	'GRAPEVINE INTERCHANGE - NICHOLS STATION 230KV CKT 1'		
FDNS	02ALL	2 11G	ASGL_2010_011	'FROM->TO'	'HITCHLAND INTERCHANGE (H TP80148301) 230/115/'	250	0.60655	106.4911	'STATELINE INTERCHANGE - STLN-DEMARC6230.00 230KV CKT 1'		
FDNS	02ALL	2 11G	ASGL_2010_011	'FROM->TO'	'HITCHLAND INTERCHANGE (H TP80148301) 230/115/'	250	0.60655	107.274	'STATELINE INTERCHANGE - STLN-DEMARC6230.00 230KV CKT 1'		
FDNS	02ALL	2 11G	ASGL_2010_011	'FROM->TO'	'HITCHLAND INTERCHANGE (H TP80148301) 230/115/'	250	0.60177	99.5	'MCCLELLAN SUB - MCLEAN RURAL SUB 115KV CKT 1'		
FDNS	02ALL	2 11G	ASGL_2010_011	'FROM->TO'	'HITCHLAND INTERCHANGE (H TP80148301) 230/115/'	250	0.60177	100.4045	'MCCLELLAN SUB - MCLEAN RURAL SUB 115KV CKT 1'		

SOLUTION GROUP	SCENARI	SEASON	SOURCE	DIRECTION	MONITORED ELEMENT	COMMON NAME	RATEB	TDF	TC%	LOAD CONTINGENCY NAME
FDNS	02ALL	2	11G	ASGI_2010_011	'FROM->TO'	'HITCHLAND INTERCHANGE (H TP80148301) 230/115/'	250	0.60177	99.5	'KIRBY SWITCHING STATION - MCCLELLAN SUB 115KV CKT 1'
FDNS	02ALL	2	11G	ASGI_2010_011	'FROM->TO'	'HITCHLAND INTERCHANGE (H TP80148301) 230/115/'	250	0.60177	100.4478	'KIRBY SWITCHING STATION - MCCLELLAN SUB 115KV CKT 1'
FDNS	02ALL	2	11G	ASGI_2010_011	'FROM->TO'	'HITCHLAND INTERCHANGE (H TP80148301) 230/115/'	250	0.60127	100	'FINNEY SWITCHING STATION - G08-18 345.00 345KV CKT 1'
FDNS	02ALL	2	11G	ASGI_2010_011	'FROM->TO'	'HITCHLAND INTERCHANGE (H TP80148301) 230/115/'	250	0.60187	100.133	'MARTIN 3115.00 - PANTEX NORTH SUB 115KV CKT 1'
FDNS	02ALL	2	11G	ASGI_2010_011	'FROM->TO'	'HITCHLAND INTERCHANGE (H TP80148301) 230/115/'	250	0.60187	101.1313	'MARTIN 3115.00 - PANTEX NORTH SUB 115KV CKT 1'
FDNS	02ALL	2	11G	ASGI_2010_011	'FROM->TO'	'HITCHLAND INTERCHANGE (H TP80148301) 230/115/'	250	0.60187	100	'HIGHLAND PARK TAP - PANTEX SOUTH SUB 115KV CKT 1'
FDNS	02ALL	2	11G	ASGI_2010_011	'FROM->TO'	'HITCHLAND INTERCHANGE (H TP80148301) 230/115/'	250	0.60187	101.0137	'HIGHLAND PARK TAP - PANTEX SOUTH SUB 115KV CKT 1'
FDNS	02ALL	2	11G	ASGI_2010_011	'FROM->TO'	'HITCHLAND INTERCHANGE (H TP80148301) 230/115/'	250	0.60187	99.7	'ASARCO_TP 3115.00 - HIGHLAND PARK TAP 115KV CKT 1'
FDNS	02ALL	2	11G	ASGI_2010_011	'FROM->TO'	'HITCHLAND INTERCHANGE (H TP80148301) 230/115/'	250	0.60187	100.7072	'ASARCO_TP 3115.00 - HIGHLAND PARK TAP 115KV CKT 1'
FDNS	02ALL	2	11G	ASGI_2010_011	'FROM->TO'	'HITCHLAND INTERCHANGE (H TP80148301) 230/115/'	250	0.60187	100.0964	'PANTEX NORTH SUB - PANTEX SOUTH SUB 115KV CKT 1'
FDNS	02ALL	2	11G	ASGI_2010_011	'FROM->TO'	'HITCHLAND INTERCHANGE (H TP80148301) 230/115/'	250	0.60187	101.0934	'PANTEX NORTH SUB - PANTEX SOUTH SUB 115KV CKT 1'
FDNS	02ALL	2	11G	ASGI_2010_011	'FROM->TO'	'HITCHLAND INTERCHANGE (H TP80148301) 230/115/'	250	0.60187	99.7	'ASARCO_TP 3115.00 - NICHOLS STATION 115KV CKT 1'
FDNS	02ALL	2	11G	ASGI_2010_011	'FROM->TO'	'HITCHLAND INTERCHANGE (H TP80148301) 230/115/'	250	0.60187	100.7064	'ASARCO_TP 3115.00 - NICHOLS STATION 115KV CKT 1'
FDNS	02ALL	2	11G	ASGI_2010_011	'FROM->TO'	'HITCHLAND INTERCHANGE (H TP80148301) 230/115/'	250	0.60195	99.6	'AMARILLO SOUTH INTERCHANGE - NICHOLS STATION 230KV C
FDNS	02ALL	2	11G	ASGI_2010_011	'FROM->TO'	'HITCHLAND INTERCHANGE (H TP80148301) 230/115/'	250	0.60195	100.496	'AMARILLO SOUTH INTERCHANGE - NICHOLS STATION 230KV C
FDNS	02ALL	2	11G	ASGI_2010_011	'FROM->TO'	'HITCHLAND INTERCHANGE (H TP80148301) 230/115/'	250	0.60406	102.5742	'AMARILLO SOUTH INTERCHANGE - G07-48T 230.00 230KV C
FDNS	02ALL	2	11G	ASGI_2010_011	'FROM->TO'	'HITCHLAND INTERCHANGE (H TP80148301) 230/115/'	250	0.60406	103.4539	'AMARILLO SOUTH INTERCHANGE - G07-48T 230.00 230KV CK
FDNS	02ALL	2	11G	ASGI_2010_011	'FROM->TO'	'HITCHLAND INTERCHANGE (H TP80148301) 230/115/'	250	0.60204	100.1232	'DEAF SMITH COUNTY INTERCHANGE - S-RANDLCO 230.00 230
FDNS	02ALL	2	11G	ASGI_2010_011	'FROM->TO'	'HITCHLAND INTERCHANGE (H TP80148301) 230/115/'	250	0.60204	100.9813	'DEAF SMITH COUNTY INTERCHANGE - S-RANDLCO 230.00 230
FDNS	02ALL	2	11G	ASGI_2010_011	'FROM->TO'	'HITCHLAND INTERCHANGE (H TP80148301) 230/115/'	250	0.60288	101.3252	'SWISHER COUNTY INTERCHANGE - TUCO INTERCHANGE 230K
FDNS	02ALL	2	11G	ASGI_2010_011	'FROM->TO'	'HITCHLAND INTERCHANGE (H TP80148301) 230/115/'	250	0.60288	102.2175	'SWISHER COUNTY INTERCHANGE - TUCO INTERCHANGE 230K
FDNS	02ALL	2	11G	ASGI_2010_011	'FROM->TO'	'HITCHLAND INTERCHANGE (H TP80148301) 230/115/'	250	0.60389	104.4775	'G07-48T 230.00 - SWISHER COUNTY INTERCHANGE 230KV CI
FDNS	02ALL	2	11G	ASGI_2010_011	'FROM->TO'	'HITCHLAND INTERCHANGE (H TP80148301) 230/115/'	250	0.60389	105.3186	'G07-48T 230.00 - SWISHER COUNTY INTERCHANGE 230KV CI
FDNS	02ALL	2	11G	ASGI_2010_011	'FROM->TO'	'HITCHLAND INTERCHANGE (H TP80148301) 230/115/'	250	0.60147	100.1806	'TOLK STATION EAST - TUCO INTERCHANGE 230KV CKT 1'
FDNS	02ALL	2	11G	ASGI_2010_011	'FROM->TO'	'HITCHLAND INTERCHANGE (H TP80148301) 230/115/'	250	0.60147	101.0647	'TOLK STATION EAST - TUCO INTERCHANGE 230KV CKT 1'
FDNS	02ALL	2	11G	ASGI_2010_011	'FROM->TO'	'HITCHLAND INTERCHANGE (H TP80148301) 230/115/'	250	0.60456	102.6584	'G05-15T 345.00 - TUCO INTERCHANGE 345KV CKT 1'
FDNS	02ALL	2	11G	ASGI_2010_011	'FROM->TO'	'HITCHLAND INTERCHANGE (H TP80148301) 230/115/'	250	0.60456	103.433	'G05-15T 345.00 - TUCO INTERCHANGE 345KV CKT 1'
FDNS	02ALL	2	11G	ASGI_2010_011	'FROM->TO'	'HITCHLAND INTERCHANGE (H TP80148301) 230/115/'	250	0.60045	95.3	'GRAY CO 345.00 - HOLCOMB 345KV CKT 1'
FDNS	02ALL	2	11G	ASGI_2010_011	'FROM->TO'	'HITCHLAND INTERCHANGE (H TP80148301) 230/115/'	250	0.60084	96.8	'MINGO - SETAB 345KV CKT 1'
FDNS	02ALL	2	11G	ASGI_2010_011	'FROM->TO'	'HITCHLAND INTERCHANGE (H TP80148301) 230/115/'	250	0.60084	97.5	'MINGO - SETAB 345KV CKT 1'
FDNS	02ALL	2	11G	ASGI_2010_011	'FROM->TO'	'HITCHLAND INTERCHANGE (H TP80148301) 230/115/'	250	0.60083	97.7	'MINGO - RED WILLLOW 345KV CKT 1'
FDNS	02ALL	2	11G	ASGI_2010_011	'FROM->TO'	'HITCHLAND INTERCHANGE (H TP80148301) 230/115/'	250	0.60127	103.1	'G03-013 345.00 - STEVENSCO 345.00 345KV CKT 1'
FDNS	02ALL	2	11G	ASGI_2010_011	'FROM->TO'	'HITCHLAND INTERCHANGE (H TP80148301) 230/115/'	250	0.60127	108.4	'G06-49 345.00 - STEVENSCO 345.00 345KV CKT 1'
FDNS	02ALL	2	11G	ASGI_2010_011	'FROM->TO'	'HITCHLAND INTERCHANGE (H TP80148301) 230/115/'	250	0.60127	105.6	'2008-047 TAP345.00 - G08-47 345.00 345KV CKT 1'
FDNS	02ALL	2	11G	ASGI_2010_011	'FROM->TO'	'HITCHLAND INTERCHANGE (H TP80148301) 230/115/'	250	0.60127	108.4	'G10-14 345.00 345/115KV TRANSFORMER CKT 1'
FDNS	02ALL	2	11G	ASGI_2010_011	'FROM->TO'	'HITCHLAND INTERCHANGE (H TP80148301) 230/115/'	250	0.60127	105.8	'2008-047 TAP345.00 - G10-01 345.00 345KV CKT 1'
FDNS	02ALL	2	11G	ASGI_2010_011	'FROM->TO'	'HITCHLAND INTERCHANGE (H TP80148301) 230/115/'	250	0.60127	104.2	'G05-17 345.00 - G05-17T 345.00 345KV CKT 1'
FDNS	02ALL	2	11G	ASGI_2010_011	'FROM->TO'	'HITCHLAND INTERCHANGE (H TP80148301) 230/115/'	250	0.60127	99.4	'G05-17 345.00 345/115KV TRANSFORMER CKT 1'
FDNS	02ALL	2	11G	ASGI_2010_011	'FROM->TO'	'HITCHLAND INTERCHANGE (H TP80148301) 230/115/'	250	0.60127	99.4	'G05-17-2 115.00 - G05-17-2 115.00 115KV CKT 1'
FDNS	02ALL	2	11G	ASGI_2010_011	'FROM->TO'	'HITCHLAND INTERCHANGE (H TP80148301) 230/115/'	250	0.60127	99.6	'G06-44 115.00 - G06-44-1 115.00 115KV CKT 1'
FDNS	02ALL	2	11G	ASGI_2010_011	'FROM->TO'	'HITCHLAND INTERCHANGE (H TP80148301) 230/115/'	250	0.60127	101.8	'G06-44 115.00 - G06-44-2 115.00 115KV CKT 1'
FDNS	02ALL	2	11G	ASGI_2010_011	'FROM->TO'	'HITCHLAND INTERCHANGE (H TP80148301) 230/115/'	250	0.60127	103.2	'G06-44 115.00 - G06-44-3 115.00 115KV CKT 1'
FDNS	02ALL	2	11G	ASGI_2010_011	'FROM->TO'	'HITCHLAND INTERCHANGE (H TP80148301) 230/115/'	250	0.60626	109.5187	'ELK CITY 230KV (ELKCTY-6) 230/138/13.8KV TRANSFORMER CK
FDNS	02ALL	2	11G	ASGI_2010_011	'FROM->TO'	'HITCHLAND INTERCHANGE (H TP80148301) 230/115/'	250	0.60626	110.2127	'ELK CITY 230KV (ELKCTY-6) 230/138/13.8KV TRANSFORMER CK
FDNS	02ALL	2	11G	ASGI_2010_011	'FROM->TO'	'HITCHLAND INTERCHANGE (H TP80148301) 230/115/'	250	0.60127	96.1	'TEXAS COUNTY INTERCHANGE 115/34.5KV TRANSFORMER CK
FDNS	02ALL	2	11G	ASGI_2010_011	'FROM->TO'	'TEXAS COUNTY INTERCHANGE - TRI COUNTY REC-'	98	0.28339	99.3	'HITCHLAND INTERCHANGE (H TP80148301) 230/115/13.2KV TR
FDNS	02ALL	2	11G	ASGI_2010_011	'TO->FROM'	'TRI COUNTY REC-COLE - TRI COUNTY REC-GUYMON	96	0.28339	97	'HITCHLAND INTERCHANGE (H TP80148301) 230/115/13.2KV TR
FDNS	02ALL	2	11G	ASGI_2010_011	'FROM->TO'	'Hansford County Switch Station - SPEARMAN INTERCH	160	0.42889	127.2001	'HITCHLAND INTERCHANGE (H TP80148301) 230/115/13.2KV TR
FDNS	02ALL	2	11G	ASGI_2010_011	'FROM->TO'	'HITCHLAND INTERCHANGE (H TP80148301) 230/115/'	250	0.59029	96.6	'Hitchland Interchange (H TB80155502) 345/230/13.2KV TRANSFOR
FDNS	02ALL	2	11G	ASGI_2010_011	'FROM->TO'	'HITCHLAND INTERCHANGE (H TP80148301) 230/115/'	250	0.59029	97.4	'Hitchland Interchange (H TB80155502) 345/230/13.2KV TRANSFOR
FDNS	02ALL	2	11G	ASGI_2010_011	'FROM->TO'	'HITCHLAND INTERCHANGE (H TP80148301) 230/115/'	250	0.60127	106.2	'Hitchland Interchange 345/0.575KV TRANSFORMER CKT 1'
FDNS	02ALL	2	11G	ASGI_2010_011	'FROM->TO'	'HITCHLAND INTERCHANGE (H TP80148301) 230/115/'	250	0.60127	105	'Hitchland Interchange (PRO G2218-01) 345/115/13.8KV TRANSFOF
FDNS	02ALL	2	11G	ASGI_2010_011	'FROM->TO'	'HITCHLAND INTERCHANGE (H TP80148301) 230/115/'	250	0.61578	101.9015	'PRINGLE INTERCHANGE (WH ALM12301) 230/115/13.2KV TRAN
FDNS	02ALL	2	11G	ASGI_2010_011	'FROM->TO'	'HITCHLAND INTERCHANGE (H TP80148301) 230/115/'	250	0.61578	102.8604	'PRINGLE INTERCHANGE (WH ALM12301) 230/115/13.2KV TRAN
FDNS	02ALL	2	11G	ASGI_2010_011	'FROM->TO'	'HITCHLAND INTERCHANGE (H TP80148301) 230/115/'	250	0.60127	99.6	'HOLCOMB 115/22.0KV TRANSFORMER CKT 1'
FDNS	02ALL	2	11G	ASGI_2010_011	'FROM->TO'	'HITCHLAND INTERCHANGE (H TP80148301) 230/115/'	250	0.60127	105.6	'G08-47 345.00 345/34.5KV TRANSFORMER CKT 1'
FDNS	02ALL	2	11G	ASGI_2010_011	'FROM->TO'	'HITCHLAND INTERCHANGE (H TP80148301) 230/115/'	250	0.60127	103.2	'G10-14 115.00 115/34.5KV TRANSFORMER CKT 1'
FDNS	02ALL	2	11G	ASGI_2010_011	'FROM->TO'	'HITCHLAND INTERCHANGE (H TP80148301) 230/115/'	250	0.60127	103.3	'G10-14 115.00 115/34.5KV TRANSFORMER CKT 1'
FDNS	02ALL	2	11G	ASGI_2010_011	'FROM->TO'	'HITCHLAND INTERCHANGE (H TP80148301) 230/115/'	250	0.60127	100	'G08-18 345.00 345/34.5KV TRANSFORMER CKT 1'
FDNS	02ALL	2	11G	ASGI_2010_011	'FROM->TO'	'HITCHLAND INTERCHANGE (H TP80148301) 230/115/'	250	0.60127	105.8	'G10-01 345.00 345/34.5KV TRANSFORMER CKT 1'
FDNS	02ALL	2	11G	ASGI_2010_011	'FROM->TO'	'HITCHLAND INTERCHANGE (H TP80148301) 230/115/'	250	0.60127	100.5	'G03-013 345.00 345/34.5KV TRANSFORMER CKT 1'
FDNS	02ALL	2	11G	ASGI_2010_011	'FROM->TO'	'HITCHLAND INTERCHANGE (H TP80148301) 230/115/'	250	0.60127	100.5	'G03-013 345.00 345/34.5KV TRANSFORMER CKT 1'
FDNS	02ALL	2	11G	ASGI_2010_011	'FROM->TO'	'HITCHLAND INTERCHANGE (H TP80148301) 230/115/'	250	0.60127	100.4	'G05-17 345.00 345/34.5KV TRANSFORMER CKT 1'
FDNS	02ALL	2	11G	ASGI_2010_011	'FROM->TO'	'HITCHLAND INTERCHANGE (H TP80148301) 230/115/'	250	0.60127	100.4	'G05-17 345.00 345/34.5KV TRANSFORMER CKT 1'
FDNS	02ALL	2	11G	ASGI_2010_011	'FROM->TO'	'HITCHLAND INTERCHANGE (H TP80148301) 230/115/'	250	0.60127	99.4	'G05-17-2 115.00 115/34.5KV TRANSFORMER CKT 1'
FDNS	02ALL	2	11G	ASGI_2010_011	'FROM->TO'	'HITCHLAND INTERCHANGE (H TP80148301) 230/115/'	250	0.60127	99.6	'G06-44-1 115.00 115/34.5KV TRANSFORMER CKT 1'
FDNS	02ALL	2	11G	ASGI_2010_011	'FROM->TO'	'HITCHLAND INTERCHANGE (H TP80148301) 230/115/'	250	0.60127	101.8	'G06-44-2 115.00 115/34.5KV TRANSFORMER CKT 1'

SOLUTION GROUP	SCENARIK SEASON	SOURCE	DIRECTION	MONITORED ELEMENT COMMON NAME	RATEB	TDF	TC%LOAD	CONTINGENCY NAME
FDNS	02ALL	3 11G	ASGL_2010_011	'FROM->TO'	'HITCHLAND INTERCHANGE (H TP80148301) 230/115/'	250	0.66637	112.688 'DWS_FRISCO 3115.00 - HITCHLAND INTERCHANGE 115KV CKT
FDNS	02ALL	3 11G	ASGL_2010_011	'FROM->TO'	'HITCHLAND INTERCHANGE (H TP80148301) 230/115/'	250	0.66637	114.3858 'DWS_FRISCO 3115.00 - HITCHLAND INTERCHANGE 115KV CKT
FDNS	02ALL	3 11G	ASGL_2010_011	'FROM->TO'	'HITCHLAND INTERCHANGE (H TP80148301) 230/115/'	250	0.58466	100 'Hitchland Interchange 345/230KV TRANSFORMER CKT 2'
FDNS	02ALL	3 11G	ASGL_2010_011	'FROM->TO'	'HITCHLAND INTERCHANGE (H TP80148301) 230/115/'	250	0.58466	100.7101 'Hitchland Interchange 345/230KV TRANSFORMER CKT 2'
FDNS	02ALL	3 11G	ASGL_2010_011	'FROM->TO'	'HITCHLAND INTERCHANGE (H TP80148301) 230/115/'	250	0.67367	108.5896 'HITCHLAND INTERCHANGE - OCHILTREE 6230.00 230KV CKT 1
FDNS	02ALL	3 11G	ASGL_2010_011	'FROM->TO'	'HITCHLAND INTERCHANGE (H TP80148301) 230/115/'	250	0.67367	110.2548 'HITCHLAND INTERCHANGE - OCHILTREE 6230.00 230KV CKT 1
FDNS	02ALL	3 11G	ASGL_2010_011	'FROM->TO'	'HITCHLAND INTERCHANGE (H TP80148301) 230/115/'	250	0.59907	100.833 'HITCHLAND INTERCHANGE - MOORE COUNTY INTERCHANGE ;
FDNS	02ALL	3 11G	ASGL_2010_011	'FROM->TO'	'HITCHLAND INTERCHANGE (H TP80148301) 230/115/'	250	0.59907	101.6943 'HITCHLAND INTERCHANGE - MOORE COUNTY INTERCHANGE ;
FDNS	02ALL	3 11G	ASGL_2010_011	'FROM->TO'	'HITCHLAND INTERCHANGE (H TP80148301) 230/115/'	250	0.6011	98.6 'BORDER 7345.00 - Hitchland Interchange 345KV CKT 1'
FDNS	02ALL	3 11G	ASGL_2010_011	'FROM->TO'	'HITCHLAND INTERCHANGE (H TP80148301) 230/115/'	250	0.6011	99.1 'BORDER 7345.00 - Hitchland Interchange 345KV CKT 1'
FDNS	02ALL	3 11G	ASGL_2010_011	'FROM->TO'	'HITCHLAND INTERCHANGE (H TP80148301) 230/115/'	250	0.6011	98.6 'BORDER 7345.00 - Hitchland Interchange 345KV CKT 2'
FDNS	02ALL	3 11G	ASGL_2010_011	'FROM->TO'	'HITCHLAND INTERCHANGE (H TP80148301) 230/115/'	250	0.6011	99.1 'BORDER 7345.00 - Hitchland Interchange 345KV CKT 2'
FDNS	02ALL	3 11G	ASGL_2010_011	'FROM->TO'	'HITCHLAND INTERCHANGE (H TP80148301) 230/115/'	250	0.60303	112.8 'G10-14 345.00 - Hitchland Interchange 345KV CKT 1'
FDNS	02ALL	3 11G	ASGL_2010_011	'FROM->TO'	'HITCHLAND INTERCHANGE (H TP80148301) 230/115/'	250	0.60311	118.3854 'G05-17T 345.00 - Hitchland Interchange 345KV CKT 1'
FDNS	02ALL	3 11G	ASGL_2010_011	'FROM->TO'	'HITCHLAND INTERCHANGE (H TP80148301) 230/115/'	250	0.60311	119.709 'G05-17T 345.00 - Hitchland Interchange 345KV CKT 1'
FDNS	02ALL	3 11G	ASGL_2010_011	'FROM->TO'	'HITCHLAND INTERCHANGE (H TP80148301) 230/115/'	250	0.6018	101.4079 '2008-047 TAP345.00 - Hitchland Interchange 345KV CKT 1'
FDNS	02ALL	3 11G	ASGL_2010_011	'FROM->TO'	'HITCHLAND INTERCHANGE (H TP80148301) 230/115/'	250	0.6018	102.1059 '2008-047 TAP345.00 - Hitchland Interchange 345KV CKT 1'
FDNS	02ALL	3 11G	ASGL_2010_011	'FROM->TO'	'HITCHLAND INTERCHANGE (H TP80148301) 230/115/'	250	0.6018	101.4079 '2008-047 TAP345.00 - Hitchland Interchange 345KV CKT 2'
FDNS	02ALL	3 11G	ASGL_2010_011	'FROM->TO'	'HITCHLAND INTERCHANGE (H TP80148301) 230/115/'	250	0.6018	102.1059 '2008-047 TAP345.00 - Hitchland Interchange 345KV CKT 2'
FDNS	02ALL	3 11G	ASGL_2010_011	'FROM->TO'	'HITCHLAND INTERCHANGE (H TP80148301) 230/115/'	250	0.69405	113.1683 'TRI COUNTY REC-COLE - TRI COUNTY REC-GUYMON 115KV CKT 1'
FDNS	02ALL	3 11G	ASGL_2010_011	'FROM->TO'	'HITCHLAND INTERCHANGE (H TP80148301) 230/115/'	250	0.69405	114.6603 'TRI COUNTY REC-COLE - TRI COUNTY REC-GUYMON 115KV CKT 1'
FDNS	02ALL	3 11G	ASGL_2010_011	'FROM->TO'	'HITCHLAND INTERCHANGE (H TP80148301) 230/115/'	250	0.69405	108.6687 'OCHILTREE 3115.00 - TRI COUNTY REC-COLE 115KV CKT 1'
FDNS	02ALL	3 11G	ASGL_2010_011	'FROM->TO'	'HITCHLAND INTERCHANGE (H TP80148301) 230/115/'	250	0.69405	110.1165 'OCHILTREE 3115.00 - TRI COUNTY REC-COLE 115KV CKT 1'
FDNS	02ALL	3 11G	ASGL_2010_011	'FROM->TO'	'HITCHLAND INTERCHANGE (H TP80148301) 230/115/'	250	0.59514	104.9146 'OCHILTREE 3115.00 - TEXAS FARMS SUB 115KV CKT 1'
FDNS	02ALL	3 11G	ASGL_2010_011	'FROM->TO'	'HITCHLAND INTERCHANGE (H TP80148301) 230/115/'	250	0.59514	106.1879 'OCHILTREE 3115.00 - TEXAS FARMS SUB 115KV CKT 1'
FDNS	02ALL	3 11G	ASGL_2010_011	'FROM->TO'	'HITCHLAND INTERCHANGE (H TP80148301) 230/115/'	250	0.59514	105.0342 'SPEARMAN SUB - TEXAS FARMS SUB 115KV CKT 1'
FDNS	02ALL	3 11G	ASGL_2010_011	'FROM->TO'	'HITCHLAND INTERCHANGE (H TP80148301) 230/115/'	250	0.59514	106.3187 'SPEARMAN SUB - TEXAS FARMS SUB 115KV CKT 1'
FDNS	02ALL	3 11G	ASGL_2010_011	'FROM->TO'	'HITCHLAND INTERCHANGE (H TP80148301) 230/115/'	250	0.67367	108.6757 'OCHILTREE 6230.00 230/115KV TRANSFORMER CKT 1'
FDNS	02ALL	3 11G	ASGL_2010_011	'FROM->TO'	'HITCHLAND INTERCHANGE (H TP80148301) 230/115/'	250	0.67367	110.421 'OCHILTREE 6230.00 230/115KV TRANSFORMER CKT 1'
FDNS	02ALL	3 11G	ASGL_2010_011	'FROM->TO'	'HITCHLAND INTERCHANGE (H TP80148301) 230/115/'	250	0.60303	104.2197 'OCHILTREE 3115.00 - PERRYTON INTERCHANGE 115KV CKT 1'
FDNS	02ALL	3 11G	ASGL_2010_011	'FROM->TO'	'HITCHLAND INTERCHANGE (H TP80148301) 230/115/'	250	0.60303	105.2512 'OCHILTREE 3115.00 - PERRYTON INTERCHANGE 115KV CKT 1'
FDNS	02ALL	3 11G	ASGL_2010_011	'FROM->TO'	'HITCHLAND INTERCHANGE (H TP80148301) 230/115/'	250	0.66589	117.8133 'DWS_FRISCO 3115.00 - SHERMAN COUNTY TAP 115KV CKT 1'
FDNS	02ALL	3 11G	ASGL_2010_011	'FROM->TO'	'HITCHLAND INTERCHANGE (H TP80148301) 230/115/'	250	0.66589	119.5993 'DWS_FRISCO 3115.00 - SHERMAN COUNTY TAP 115KV CKT 1'
FDNS	02ALL	3 11G	ASGL_2010_011	'FROM->TO'	'HITCHLAND INTERCHANGE (H TP80148301) 230/115/'	250	0.61003	104.6186 'SHERMAN COUNTY SUB - SHERMAN COUNTY TAP 115KV CKT 1'
FDNS	02ALL	3 11G	ASGL_2010_011	'FROM->TO'	'HITCHLAND INTERCHANGE (H TP80148301) 230/115/'	250	0.61003	105.7013 'SHERMAN COUNTY SUB - SHERMAN COUNTY TAP 115KV CKT 1'
FDNS	02ALL	3 11G	ASGL_2010_011	'FROM->TO'	'HITCHLAND INTERCHANGE (H TP80148301) 230/115/'	250	0.60983	105.6309 'DALLAM COUNTY INTERCHANGE - SHERMAN COUNTY SUB 115KV CKT 1'
FDNS	02ALL	3 11G	ASGL_2010_011	'FROM->TO'	'HITCHLAND INTERCHANGE (H TP80148301) 230/115/'	250	0.60983	106.7298 'DALLAM COUNTY INTERCHANGE - SHERMAN COUNTY SUB 115KV CKT 1'
FDNS	02ALL	3 11G	ASGL_2010_011	'FROM->TO'	'HITCHLAND INTERCHANGE (H TP80148301) 230/115/'	250	0.63002	108.9419 'RB-SPURLOCK3115.00 - SHERMAN COUNTY TAP 115KV CKT 1'
FDNS	02ALL	3 11G	ASGL_2010_011	'FROM->TO'	'HITCHLAND INTERCHANGE (H TP80148301) 230/115/'	250	0.63002	110.221 'RB-SPURLOCK3115.00 - SHERMAN COUNTY TAP 115KV CKT 1'
FDNS	02ALL	3 11G	ASGL_2010_011	'FROM->TO'	'HITCHLAND INTERCHANGE (H TP80148301) 230/115/'	250	0.63002	108.5763 'MOORE COUNTY INTERCHANGE EAST BUS - RB-SPURLOCK31
FDNS	02ALL	3 11G	ASGL_2010_011	'FROM->TO'	'HITCHLAND INTERCHANGE (H TP80148301) 230/115/'	250	0.63002	109.8463 'MOORE COUNTY INTERCHANGE EAST BUS - RB-SPURLOCK31
FDNS	02ALL	3 11G	ASGL_2010_011	'FROM->TO'	'HITCHLAND INTERCHANGE (H TP80148301) 230/115/'	250	0.6918	124.6854 'Hansford County Switch Station - SPEARMAN INTERCHANGE 115KV CKT 1'
FDNS	02ALL	3 11G	ASGL_2010_011	'FROM->TO'	'HITCHLAND INTERCHANGE (H TP80148301) 230/115/'	250	0.6918	126.756 'Hansford County Switch Station - SPEARMAN INTERCHANGE 115KV CKT 1'
FDNS	02ALL	3 11G	ASGL_2010_011	'FROM->TO'	'HITCHLAND INTERCHANGE (H TP80148301) 230/115/'	250	0.59514	105.3851 'SPEARMAN INTERCHANGE - SPEARMAN SUB 115KV CKT 1'
FDNS	02ALL	3 11G	ASGL_2010_011	'FROM->TO'	'HITCHLAND INTERCHANGE (H TP80148301) 230/115/'	250	0.59514	106.6695 'SPEARMAN INTERCHANGE - SPEARMAN SUB 115KV CKT 1'
FDNS	02ALL	3 11G	ASGL_2010_011	'FROM->TO'	'HITCHLAND INTERCHANGE (H TP80148301) 230/115/'	250	0.61991	104.2586 'PRINGLE INTERCHANGE - SPEARMAN INTERCHANGE 115KV CKT 1'
FDNS	02ALL	3 11G	ASGL_2010_011	'FROM->TO'	'HITCHLAND INTERCHANGE (H TP80148301) 230/115/'	250	0.61991	105.2962 'PRINGLE INTERCHANGE - SPEARMAN INTERCHANGE 115KV CKT 1'
FDNS	02ALL	3 11G	ASGL_2010_011	'FROM->TO'	'HITCHLAND INTERCHANGE (H TP80148301) 230/115/'	250	0.61736	106.2255 'Harrington Station East Bus - PRINGLE INTERCHANGE 230KV CKT 1'
FDNS	02ALL	3 11G	ASGL_2010_011	'FROM->TO'	'HITCHLAND INTERCHANGE (H TP80148301) 230/115/'	250	0.61736	107.2108 'Harrington Station East Bus - PRINGLE INTERCHANGE 230KV CKT 1'
FDNS	02ALL	3 11G	ASGL_2010_011	'FROM->TO'	'HITCHLAND INTERCHANGE (H TP80148301) 230/115/'	250	0.60424	104.2203 'BLACKHAWK STATION S. - WO_OPERATNG3115.00 115KV CKT 1'
FDNS	02ALL	3 11G	ASGL_2010_011	'FROM->TO'	'HITCHLAND INTERCHANGE (H TP80148301) 230/115/'	250	0.60424	105.2678 'BLACKHAWK STATION S. - WO_OPERATNG3115.00 115KV CKT 1'
FDNS	02ALL	3 11G	ASGL_2010_011	'FROM->TO'	'HITCHLAND INTERCHANGE (H TP80148301) 230/115/'	250	0.60424	104.057 'HUTCHINSON COUNTY INTERCHANGE N. - WO_OPERATNG3115.00 115KV CKT 1'
FDNS	02ALL	3 11G	ASGL_2010_011	'FROM->TO'	'HITCHLAND INTERCHANGE (H TP80148301) 230/115/'	250	0.60424	105.0956 'HUTCHINSON COUNTY INTERCHANGE N. - WO_OPERATNG3115.00 115KV CKT 1'
FDNS	02ALL	3 11G	ASGL_2010_011	'FROM->TO'	'HITCHLAND INTERCHANGE (H TP80148301) 230/115/'	250	0.61003	106.0539 'G10-07T 115.00 - RIVERVIEW INTERCHANGE 115KV CKT 1'
FDNS	02ALL	3 11G	ASGL_2010_011	'FROM->TO'	'HITCHLAND INTERCHANGE (H TP80148301) 230/115/'	250	0.61003	107.1922 'G10-07T 115.00 - RIVERVIEW INTERCHANGE 115KV CKT 1'
FDNS	02ALL	3 11G	ASGL_2010_011	'FROM->TO'	'HITCHLAND INTERCHANGE (H TP80148301) 230/115/'	250	0.60715	104.1914 'HUTCHINSON COUNTY INTERCHANGE - NICHOLS STATION 230KV CKT 1'
FDNS	02ALL	3 11G	ASGL_2010_011	'FROM->TO'	'HITCHLAND INTERCHANGE (H TP80148301) 230/115/'	250	0.60715	105.2438 'HUTCHINSON COUNTY INTERCHANGE - NICHOLS STATION 230KV CKT 1'
FDNS	02ALL	3 11G	ASGL_2010_011	'FROM->TO'	'HITCHLAND INTERCHANGE (H TP80148301) 230/115/'	250	0.60771	110.6306 'GRAPEVINE INTERCHANGE - STATELINE INTERCHANGE 230KV CKT 1'
FDNS	02ALL	3 11G	ASGL_2010_011	'FROM->TO'	'HITCHLAND INTERCHANGE (H TP80148301) 230/115/'	250	0.60771	111.5008 'GRAPEVINE INTERCHANGE - STATELINE INTERCHANGE 230KV CKT 1'
FDNS	02ALL	3 11G	ASGL_2010_011	'FROM->TO'	'HITCHLAND INTERCHANGE (H TP80148301) 230/115/'	250	0.60521	107.5245 'GRAPEVINE INTERCHANGE - NICHOLS STATION 230KV CKT 1'
FDNS	02ALL	3 11G	ASGL_2010_011	'FROM->TO'	'HITCHLAND INTERCHANGE (H TP80148301) 230/115/'	250	0.60521	108.4233 'GRAPEVINE INTERCHANGE - NICHOLS STATION 230KV CKT 1'
FDNS	02ALL	3 11G	ASGL_2010_011	'FROM->TO'	'HITCHLAND INTERCHANGE (H TP80148301) 230/115/'	250	0.6023	98.8 'BORDER 7345.00 - TUCO INTERCHANGE 345KV CKT 1'
FDNS	02ALL	3 11G	ASGL_2010_011	'FROM->TO'	'HITCHLAND INTERCHANGE (H TP80148301) 230/115/'	250	0.6023	99.7 'BORDER 7345.00 - TUCO INTERCHANGE 345KV CKT 1'
FDNS	02ALL	3 11G	ASGL_2010_011	'FROM->TO'	'HITCHLAND INTERCHANGE (H TP80148301) 230/115/'	250	0.60771	109.9038 'STATELINE INTERCHANGE - STLN-DEMARC6230.00 230KV CKT 1'
FDNS	02ALL	3 11G	ASGL_2010_011	'FROM->TO'	'HITCHLAND INTERCHANGE (H TP80148301) 230/115/'	250	0.60771	110.7897 'STATELINE INTERCHANGE - STLN-DEMARC6230.00 230KV CKT 1'
FDNS	02ALL	3 11G	ASGL_2010_011	'FROM->TO'	'HITCHLAND INTERCHANGE (H TP80148301) 230/115/'	250	0.60303	104.8 'FINNEY SWITCHING STATION - G08-18 345.00 345KV CKT 1'
FDNS	02ALL	3 11G	ASGL_2010_011	'FROM->TO'	'HITCHLAND INTERCHANGE (H TP80148301) 230/115/'	250	0.60303	98.8 'MAJESTC_WND3115.00 - MARTIN 3115.00 115KV CKT 1'

SOLUTION GROUP	SCENARIO	SEASON	SOURCE	DIRECTION	MONITORED ELEMENT	COMMON NAME	RATEB	TDF	TC%	LOAD CONTINGENCY	NAME
FDNS	02ALL	3 11G	ASGI_2010_011	'FROM->TO'	'HITCHLAND INTERCHANGE (H TP80148301) 230/115/'		250	0.60361	104.8289	'MARTIN 3115.00 - PANTEX NORTH SUB 115KV CKT 1'	
FDNS	02ALL	3 11G	ASGI_2010_011	'FROM->TO'	'HITCHLAND INTERCHANGE (H TP80148301) 230/115/'		250	0.60361	105.9029	'MARTIN 3115.00 - PANTEX NORTH SUB 115KV CKT 1'	
FDNS	02ALL	3 11G	ASGI_2010_011	'FROM->TO'	'HITCHLAND INTERCHANGE (H TP80148301) 230/115/'		250	0.60361	104.7176	'HIGHLAND PARK TAP - PANTEX SOUTH SUB 115KV CKT 1'	
FDNS	02ALL	3 11G	ASGI_2010_011	'FROM->TO'	'HITCHLAND INTERCHANGE (H TP80148301) 230/115/'		250	0.60361	105.7882	'HIGHLAND PARK TAP - PANTEX SOUTH SUB 115KV CKT 1'	
FDNS	02ALL	3 11G	ASGI_2010_011	'FROM->TO'	'HITCHLAND INTERCHANGE (H TP80148301) 230/115/'		250	0.60361	104.4241	'ASARCO_TP 3115.00 - HIGHLAND PARK TAP 115KV CKT 1'	
FDNS	02ALL	3 11G	ASGI_2010_011	'FROM->TO'	'HITCHLAND INTERCHANGE (H TP80148301) 230/115/'		250	0.60361	105.4843	'ASARCO_TP 3115.00 - HIGHLAND PARK TAP 115KV CKT 1'	
FDNS	02ALL	3 11G	ASGI_2010_011	'FROM->TO'	'HITCHLAND INTERCHANGE (H TP80148301) 230/115/'		250	0.60361	104.7819	'PANTEX NORTH SUB - PANTEX SOUTH SUB 115KV CKT 1'	
FDNS	02ALL	3 11G	ASGI_2010_011	'FROM->TO'	'HITCHLAND INTERCHANGE (H TP80148301) 230/115/'		250	0.60361	105.8553	'PANTEX NORTH SUB - PANTEX SOUTH SUB 115KV CKT 1'	
FDNS	02ALL	3 11G	ASGI_2010_011	'FROM->TO'	'HITCHLAND INTERCHANGE (H TP80148301) 230/115/'		250	0.60497	97.8	'G05-17T 345.00 - POTTER COUNTY INTERCHANGE 345KV CK'	
FDNS	02ALL	3 11G	ASGI_2010_011	'FROM->TO'	'HITCHLAND INTERCHANGE (H TP80148301) 230/115/'		250	0.60497	98.6	'G05-17T 345.00 - POTTER COUNTY INTERCHANGE 345KV CK'	
FDNS	02ALL	3 11G	ASGI_2010_011	'FROM->TO'	'HITCHLAND INTERCHANGE (H TP80148301) 230/115/'		250	0.60361	104.4238	'ASARCO_TP 3115.00 - NICHOLS STATION 115KV CKT 1'	
FDNS	02ALL	3 11G	ASGI_2010_011	'FROM->TO'	'HITCHLAND INTERCHANGE (H TP80148301) 230/115/'		250	0.60361	105.4836	'ASARCO_TP 3115.00 - NICHOLS STATION 115KV CKT 1'	
FDNS	02ALL	3 11G	ASGI_2010_011	'FROM->TO'	'HITCHLAND INTERCHANGE (H TP80148301) 230/115/'		250	0.6037	104.312	'AMARILLO SOUTH INTERCHANGE - NICHOLS STATION 230KV C	
FDNS	02ALL	3 11G	ASGI_2010_011	'FROM->TO'	'HITCHLAND INTERCHANGE (H TP80148301) 230/115/'		250	0.6037	105.2847	'AMARILLO SOUTH INTERCHANGE - NICHOLS STATION 230KV C	
FDNS	02ALL	3 11G	ASGI_2010_011	'FROM->TO'	'HITCHLAND INTERCHANGE (H TP80148301) 230/115/'		250	0.60577	107.1671	'AMARILLO SOUTH INTERCHANGE - G07-48T 230.00 230KV CK	
FDNS	02ALL	3 11G	ASGI_2010_011	'FROM->TO'	'HITCHLAND INTERCHANGE (H TP80148301) 230/115/'		250	0.60577	108.1231	'AMARILLO SOUTH INTERCHANGE - G07-48T 230.00 230KV CK	
FDNS	02ALL	3 11G	ASGI_2010_011	'FROM->TO'	'HITCHLAND INTERCHANGE (H TP80148301) 230/115/'		250	0.60379	104.8717	'DEAF SMITH COUNTY INTERCHANGE - S-RANDLCO 230.00 230V	
FDNS	02ALL	3 11G	ASGI_2010_011	'FROM->TO'	'HITCHLAND INTERCHANGE (H TP80148301) 230/115/'		250	0.60379	105.8074	'DEAF SMITH COUNTY INTERCHANGE - S-RANDLCO 230.00 230V	
FDNS	02ALL	3 11G	ASGI_2010_011	'FROM->TO'	'HITCHLAND INTERCHANGE (H TP80148301) 230/115/'		250	0.6046	106.008	'SWISHER COUNTY INTERCHANGE - TUCO INTERCHANGE 230K	
FDNS	02ALL	3 11G	ASGI_2010_011	'FROM->TO'	'HITCHLAND INTERCHANGE (H TP80148301) 230/115/'		250	0.6046	106.9757	'SWISHER COUNTY INTERCHANGE - TUCO INTERCHANGE 230K	
FDNS	02ALL	3 11G	ASGI_2010_011	'FROM->TO'	'HITCHLAND INTERCHANGE (H TP80148301) 230/115/'		250	0.6056	109.0951	'G07-48T 230.00 - SWISHER COUNTY INTERCHANGE 230KV CI	
FDNS	02ALL	3 11G	ASGI_2010_011	'FROM->TO'	'HITCHLAND INTERCHANGE (H TP80148301) 230/115/'		250	0.6056	110.0211	'G07-48T 230.00 - SWISHER COUNTY INTERCHANGE 230KV CI	
FDNS	02ALL	3 11G	ASGI_2010_011	'FROM->TO'	'HITCHLAND INTERCHANGE (H TP80148301) 230/115/'		250	0.6032	104.9029	'TOLK STATION EAST - TUCO INTERCHANGE 230KV CKT 1'	
FDNS	02ALL	3 11G	ASGI_2010_011	'FROM->TO'	'HITCHLAND INTERCHANGE (H TP80148301) 230/115/'		250	0.6032	105.8629	'TOLK STATION EAST - TUCO INTERCHANGE 230KV CKT 1'	
FDNS	02ALL	3 11G	ASGI_2010_011	'FROM->TO'	'HITCHLAND INTERCHANGE (H TP80148301) 230/115/'		250	0.60546	105.357	'G05-15T 345.00 - TUCO INTERCHANGE 345KV CKT 1'	
FDNS	02ALL	3 11G	ASGI_2010_011	'FROM->TO'	'HITCHLAND INTERCHANGE (H TP80148301) 230/115/'		250	0.60546	106.2682	'G05-15T 345.00 - TUCO INTERCHANGE 345KV CKT 1'	
FDNS	02ALL	3 11G	ASGI_2010_011	'FROM->TO'	'HITCHLAND INTERCHANGE (H TP80148301) 230/115/'		250	0.60237	100.3662	'GRAY CO 345.00 - HOLCOMB 345KV CKT 1'	
FDNS	02ALL	3 11G	ASGI_2010_011	'FROM->TO'	'HITCHLAND INTERCHANGE (H TP80148301) 230/115/'		250	0.60237	100.8697	'GRAY CO 345.00 - HOLCOMB 345KV CKT 1'	
FDNS	02ALL	3 11G	ASGI_2010_011	'FROM->TO'	'HITCHLAND INTERCHANGE (H TP80148301) 230/115/'		250	0.6024	100.1386	'GRAY CO 345.00 - SPEARVILLE 345KV CKT 1'	
FDNS	02ALL	3 11G	ASGI_2010_011	'FROM->TO'	'HITCHLAND INTERCHANGE (H TP80148301) 230/115/'		250	0.6024	100.5742	'GRAY CO 345.00 - SPEARVILLE 345KV CKT 1'	
FDNS	02ALL	3 11G	ASGI_2010_011	'FROM->TO'	'HITCHLAND INTERCHANGE (H TP80148301) 230/115/'		250	0.60303	107.8	'G03-013 345.00 - STEVENSCO 345.00 345KV CKT 1'	
FDNS	02ALL	3 11G	ASGI_2010_011	'FROM->TO'	'HITCHLAND INTERCHANGE (H TP80148301) 230/115/'		250	0.60303	113	'G06-49 345.00 - STEVENSCO 345.00 345KV CKT 1'	
FDNS	02ALL	3 11G	ASGI_2010_011	'FROM->TO'	'HITCHLAND INTERCHANGE (H TP80148301) 230/115/'		250	0.60303	110.2	'2008-047 TAP345.00 - G08-47 345.00 345KV CKT 1'	
FDNS	02ALL	3 11G	ASGI_2010_011	'FROM->TO'	'HITCHLAND INTERCHANGE (H TP80148301) 230/115/'		250	0.60303	99	'G10-07 115.00 - G10-07T 115.00 115KV CKT 1'	
FDNS	02ALL	3 11G	ASGI_2010_011	'FROM->TO'	'HITCHLAND INTERCHANGE (H TP80148301) 230/115/'		250	0.60303	112.8	'G10-14 345.00 345/115KV TRANSFORMER CKT 1'	
FDNS	02ALL	3 11G	ASGI_2010_011	'FROM->TO'	'HITCHLAND INTERCHANGE (H TP80148301) 230/115/'		250	0.60303	110.4	'2008-047 TAP345.00 - G10-01 345.00 345KV CKT 1'	
FDNS	02ALL	3 11G	ASGI_2010_011	'FROM->TO'	'HITCHLAND INTERCHANGE (H TP80148301) 230/115/'		250	0.60303	108.7	'G05-17 345.00 - G05-17T 345.00 345KV CKT 1'	
FDNS	02ALL	3 11G	ASGI_2010_011	'FROM->TO'	'HITCHLAND INTERCHANGE (H TP80148301) 230/115/'		250	0.60303	104.2	'G05-17 345.00 345/115KV TRANSFORMER CKT 1'	
FDNS	02ALL	3 11G	ASGI_2010_011	'FROM->TO'	'HITCHLAND INTERCHANGE (H TP80148301) 230/115/'		250	0.60303	104.2	'G05-17-2 115.00 - G05-17-2 115.00 115KV CKT 1'	
FDNS	02ALL	3 11G	ASGI_2010_011	'FROM->TO'	'HITCHLAND INTERCHANGE (H TP80148301) 230/115/'		250	0.60303	104.3	'G06-44 115.00 - G06-44-1 115.00 115KV CKT 1'	
FDNS	02ALL	3 11G	ASGI_2010_011	'FROM->TO'	'HITCHLAND INTERCHANGE (H TP80148301) 230/115/'		250	0.60303	106.5	'G06-44 115.00 - G06-44-2 115.00 115KV CKT 1'	
FDNS	02ALL	3 11G	ASGI_2010_011	'FROM->TO'	'HITCHLAND INTERCHANGE (H TP80148301) 230/115/'		250	0.60303	107.9	'G06-44 115.00 - G06-44-3 115.00 115KV CKT 1'	
FDNS	02ALL	3 11G	ASGI_2010_011	'FROM->TO'	'HITCHLAND INTERCHANGE (H TP80148301) 230/115/'		250	0.60742	112.9695	'ELK CITY 230KV (ELKCTY-6) 230/138/13.8KV TRANSFORMER CK	
FDNS	02ALL	3 11G	ASGI_2010_011	'FROM->TO'	'HITCHLAND INTERCHANGE (H TP80148301) 230/115/'		250	0.60742	113.7794	'ELK CITY 230KV (ELKCTY-6) 230/138/13.8KV TRANSFORMER CK	
FDNS	02ALL	3 11G	ASGI_2010_011	'FROM->TO'	'HITCHLAND INTERCHANGE (H TP80148301) 230/115/'		250	0.60303	100.9	'TEXAS COUNTY INTERCHANGE 115/34.5KV TRANSFORMER CK	
FDNS	02ALL	3 11G	ASGI_2010_011	'FROM->TO'	'TEXAS COUNTY INTERCHANGE - TRI COUNTY REC-'		98	0.28363	102.3528	'HITCHLAND INTERCHANGE (H TP80148301) 230/115/13.2KV TR'	
FDNS	02ALL	3 11G	ASGI_2010_011	'TO->FROM'	'TRI COUNTY REC-COLE - TRI COUNTY REC-GUYMON		96	0.28363	100	'HITCHLAND INTERCHANGE (H TP80148301) 230/115/13.2KV TR'	
FDNS	02ALL	3 11G	ASGI_2010_011	'FROM->TO'	'Hansford County Switch Station - SPEARMAN INTERCH		160	0.42869	127.6904	'HITCHLAND INTERCHANGE (H TP80148301) 230/115/13.2KV TR'	
FDNS	02ALL	3 11G	ASGI_2010_011	'FROM->TO'	'HITCHLAND INTERCHANGE (H TP80148301) 230/115/'		250	0.59192	101.0829	'Hitchland Interchange (H TB80155502) 345/230/13.2KV TRANSFOR	
FDNS	02ALL	3 11G	ASGI_2010_011	'FROM->TO'	'HITCHLAND INTERCHANGE (H TP80148301) 230/115/'		250	0.59192	101.925	'Hitchland Interchange (H TB80155502) 345/230/13.2KV TRANSFOR	
FDNS	02ALL	3 11G	ASGI_2010_011	'FROM->TO'	'HITCHLAND INTERCHANGE (H TP80148301) 230/115/'		250	0.60303	110.7	'Hitchland Interchange 345/0.575KV TRANSFORMER CKT 1'	
FDNS	02ALL	3 11G	ASGI_2010_011	'FROM->TO'	'HITCHLAND INTERCHANGE (H TP80148301) 230/115/'		250	0.60303	109.6	'Hitchland Interchange (PRO G2218-01) 345/115/13.8KV TRANSFOF	
FDNS	02ALL	3 11G	ASGI_2010_011	'FROM->TO'	'HITCHLAND INTERCHANGE (H TP80148301) 230/115/'		250	0.61736	106.245	'PRINGLE INTERCHANGE (WH ALM12301) 230/115/13.2KV TRAN	
FDNS	02ALL	3 11G	ASGI_2010_011	'FROM->TO'	'HITCHLAND INTERCHANGE (H TP80148301) 230/115/'		250	0.61736	107.226	'PRINGLE INTERCHANGE (WH ALM12301) 230/115/13.2KV TRAN	
FDNS	02ALL	3 11G	ASGI_2010_011	'FROM->TO'	'HITCHLAND INTERCHANGE (H TP80148301) 230/115/'		250	0.60303	99.3	'BLACKHAWK STATION N. 115/13.8KV TRANSFORMER CKT 1'	
FDNS	02ALL	3 11G	ASGI_2010_011	'FROM->TO'	'HITCHLAND INTERCHANGE (H TP80148301) 230/115/'		250	0.60303	99.3	'BLACKHAWK STATION S. 115/13.8KV TRANSFORMER CKT 1'	
FDNS	02ALL	3 11G	ASGI_2010_011	'FROM->TO'	'HITCHLAND INTERCHANGE (H TP80148301) 230/115/'		250	0.60303	99.1	'HARRINGTON STATION 230/24.0KV TRANSFORMER CKT 1'	
FDNS	02ALL	3 11G	ASGI_2010_011	'FROM->TO'	'HITCHLAND INTERCHANGE (H TP80148301) 230/115/'		250	0.60303	99.1	'Harrington Station Mid Bus 230/24.0KV TRANSFORMER CKT 1'	
FDNS	02ALL	3 11G	ASGI_2010_011	'FROM->TO'	'HITCHLAND INTERCHANGE (H TP80148301) 230/115/'		250	0.60303	99.1	'Harrington Station East Bus 230/24.0KV TRANSFORMER CKT 1'	
FDNS	02ALL	3 11G	ASGI_2010_011	'FROM->TO'	'HITCHLAND INTERCHANGE (H TP80148301) 230/115/'		250	0.60303	104.1	'HOLCOMB 115/22.0KV TRANSFORMER CKT 1'	
FDNS	02ALL	3 11G	ASGI_2010_011	'FROM->TO'	'HITCHLAND INTERCHANGE (H TP80148301) 230/115/'		250	0.60303	110.2	'G08-47 345.00 345/34.5KV TRANSFORMER CKT 1'	
FDNS	02ALL	3 11G	ASGI_2010_011	'FROM->TO'	'HITCHLAND INTERCHANGE (H TP80148301) 230/115/'		250	0.60303	99	'G10-07 115.00 115/34.5KV TRANSFORMER CKT 1'	
FDNS	02ALL	3 11G	ASGI_2010_011	'FROM->TO'	'HITCHLAND INTERCHANGE (H TP80148301) 230/115/'		250	0.60303	107.8	'G10-14 115.00 115/34.5KV TRANSFORMER CKT 1'	
FDNS	02ALL	3 11G	ASGI_2010_011	'FROM->TO'	'HITCHLAND INTERCHANGE (H TP80148301) 230/115/'		250	0.60303	107.9	'G10-14 115.00 115/34.5KV TRANSFORMER CKT 1'	
FDNS	02ALL	3 11G	ASGI_2010_011	'FROM->TO'	'HITCHLAND INTERCHANGE (H TP80148301) 230/115/'		250	0.60303	104.8	'G08-18 345.00 345/34.5KV TRANSFORMER CKT 1'	
FDNS	02ALL	3 11G	ASGI_2010_011	'FROM->TO'	'HITCHLAND INTERCHANGE (H TP80148301) 230/115/'		250	0.60303	110.4	'G10-01 345.00 345/34.5KV TRANSFORMER CKT 1'	
FDNS	02ALL	3 11G	ASGI_2010_011	'FROM->TO'	'HITCHLAND INTERCHANGE (H TP80148301) 230/115/'		250	0.60303	105.2	'G03-013 345.00 345/34.5KV TRANSFORMER CKT 1'	

SOLUTION GROUP	SCENARIK	SEASON	SOURCE	DIRECTION	MONITORED ELEMENT	COMMON NAME	RATEB	TDF	TC%	LOAD	CONTINGENCY	NAME
FDNS	02ALL	3 11G	ASGI_2010_011	'FROM->TO'	'HITCHLAND INTERCHANGE (H TP80148301) 230/115/'		250	0.60303	105.2	'G03-013	345.00	345/34.5KV TRANSFORMER CKT 1'
FDNS	02ALL	3 11G	ASGI_2010_011	'FROM->TO'	'HITCHLAND INTERCHANGE (H TP80148301) 230/115/'		250	0.60303	105.1	'G05-17	345.00	345/34.5KV TRANSFORMER CKT 1'
FDNS	02ALL	3 11G	ASGI_2010_011	'FROM->TO'	'HITCHLAND INTERCHANGE (H TP80148301) 230/115/'		250	0.60303	105.1	'G05-17	345.00	345/34.5KV TRANSFORMER CKT 1'
FDNS	02ALL	3 11G	ASGI_2010_011	'FROM->TO'	'HITCHLAND INTERCHANGE (H TP80148301) 230/115/'		250	0.60303	104.2	'G05-17-2	115.00	115/34.5KV TRANSFORMER CKT 1'
FDNS	02ALL	3 11G	ASGI_2010_011	'FROM->TO'	'HITCHLAND INTERCHANGE (H TP80148301) 230/115/'		250	0.60303	104.3	'G06-44-1	115.00	115/34.5KV TRANSFORMER CKT 1'
FDNS	02ALL	3 11G	ASGI_2010_011	'FROM->TO'	'HITCHLAND INTERCHANGE (H TP80148301) 230/115/'		250	0.60303	106.5	'G06-44-2	115.00	115/34.5KV TRANSFORMER CKT 1'
FDNS	02ALL	3 11G	ASGI_2010_011	'FROM->TO'	'HITCHLAND INTERCHANGE (H TP80148301) 230/115/'		250	0.60303	107.9	'G06-44-3	115.00	115/34.5KV TRANSFORMER CKT 1'
FDNS	02ALL	3 11G	ASGI_2010_011	'FROM->TO'	'HITCHLAND INTERCHANGE (H TP80148301) 230/115/'		250	0.60303	113	'G06-49	345.00	345/34.5KV TRANSFORMER CKT 1'
FDNS	02ALL	3 11G	ASGI_2010_011	'FROM->TO'	'HITCHLAND INTERCHANGE (H TP80148301) 230/115/'		250	0.60305	102.5969	'DBL-SPRVL-CO'		
FDNS	02ALL	3 11G	ASGI_2010_011	'FROM->TO'	'HITCHLAND INTERCHANGE (H TP80148301) 230/115/'		250	0.60305	102.4161	'DBL-COM-MEDL'		
FDNS	02ALL	3 11G	ASGI_2010_011	'FROM->TO'	'HITCHLAND INTERCHANGE (H TP80148301) 230/115/'		250	0.60211	99.6	'DBL-MEDLO-WI'		
FDNS	02ALL	3 11G	ASGI_2010_011	'FROM->TO'	'HITCHLAND INTERCHANGE (H TP80148301) 230/115/'		250	0.60211	100.3848	'DBL-MEDLO-WI'		
FDNS	02ALL	3 11G	ASGI_2010_011	'TO->FROM'	'FINNEY SWITCHING STATION - STEVENSCO 345.00		1052	0.22752	113.9175	'DBL-G0847-WO'		
FDNS	02ALL	3 11G	ASGI_2010_011	'FROM->TO'	'HITCHLAND INTERCHANGE (H TP80148301) 230/115/'		250	0.60228	101.0334	'DBL-WOOD-MED'		
FDNS	02ALL	3 11G	ASGI_2010_011	'FROM->TO'	'HITCHLAND INTERCHANGE (H TP80148301) 230/115/'		250	0.60228	101.7435	'DBL-WOOD-MED'		
FDNS	02ALL	3 11G	ASGI_2010_011	'FROM->TO'	'HITCHLAND INTERCHANGE (H TP80148301) 230/115/'		250	0.60771	109.9038	'SPP-SWPS-02'		
FDNS	02ALL	3 11G	ASGI_2010_011	'FROM->TO'	'HITCHLAND INTERCHANGE (H TP80148301) 230/115/'		250	0.60771	110.7897	'SPP-SWPS-02'		
FDNS	02ALL	3 11G	ASGI_2010_011	'FROM->TO'	'HITCHLAND INTERCHANGE (H TP80148301) 230/115/'		250	0.60771	109.7429	'SPP-SWPS-02A'		
FDNS	02ALL	3 11G	ASGI_2010_011	'FROM->TO'	'HITCHLAND INTERCHANGE (H TP80148301) 230/115/'		250	0.60771	110.6298	'SPP-SWPS-02A'		
FDNS	02ALL	3 11G	ASGI_2010_011	'FROM->TO'	'HITCHLAND INTERCHANGE (H TP80148301) 230/115/'		250	0.60772	110.6983	'SPP-SWPS-03'		
FDNS	02ALL	3 11G	ASGI_2010_011	'FROM->TO'	'HITCHLAND INTERCHANGE (H TP80148301) 230/115/'		250	0.60772	111.5529	'SPP-SWPS-03'		
FDNS	02ALL	3 11G	ASGI_2010_011	'FROM->TO'	'HITCHLAND INTERCHANGE (H TP80148301) 230/115/'		250	0.61242	101.5929	'SPP-SWPS-K31'		
FDNS	02ALL	3 11G	ASGI_2010_011	'FROM->TO'	'HITCHLAND INTERCHANGE (H TP80148301) 230/115/'		250	0.61736	106.227	'SPP-SWPS-K43'		
FDNS	02ALL	3 11G	ASGI_2010_011	'FROM->TO'	'HITCHLAND INTERCHANGE (H TP80148301) 230/115/'		250	0.61736	107.2078	'SPP-SWPS-K43'		
FDNS	02ALL	3 11G	ASGI_2010_011	'FROM->TO'	'HITCHLAND INTERCHANGE (H TP80148301) 230/115/'		250	0.69405	114.2764	'SPP-SWPS-T01'		
FDNS	02ALL	3 11G	ASGI_2010_011	'FROM->TO'	'HITCHLAND INTERCHANGE (H TP80148301) 230/115/'		250	0.69405	115.8007	'SPP-SWPS-T01'		
FDNS	02ALL	3 11G	ASGI_2010_011	'FROM->TO'	'HITCHLAND INTERCHANGE (H TP80148301) 230/115/'		250	0.60424	104.4656	'SPP-SWPS-T48'		
FDNS	02ALL	3 11G	ASGI_2010_011	'FROM->TO'	'HITCHLAND INTERCHANGE (H TP80148301) 230/115/'		250	0.60424	105.514	'SPP-SWPS-T48'		
FDNS	02ALL	3 11G	ASGI_2010_011	'FROM->TO'	'HITCHLAND INTERCHANGE (H TP80148301) 230/115/'		250	0.60347	104.0419	'SPP-SWPS-T54'		
FDNS	02ALL	3 11G	ASGI_2010_011	'FROM->TO'	'HITCHLAND INTERCHANGE (H TP80148301) 230/115/'		250	0.60347	105.0312	'SPP-SWPS-T54'		
FDNS	02ALL	3 11G	ASGI_2010_011	'FROM->TO'	'HITCHLAND INTERCHANGE (H TP80148301) 230/115/'		250	0.60361	105.157	'SPP-SWPS-V02'		
FDNS	02ALL	3 11G	ASGI_2010_011	'FROM->TO'	'HITCHLAND INTERCHANGE (H TP80148301) 230/115/'		250	0.60361	106.232	'SPP-SWPS-V02'		
FDNS	02ALL	3 11G	ASGI_2010_011	'FROM->TO'	'HITCHLAND INTERCHANGE (H TP80148301) 230/115/'		250	0.60303	104.6685	'GEN335831 1-RIVERBEND UNIT#1'		
FDNS	02ALL	3 11G	ASGI_2010_011	'FROM->TO'	'HITCHLAND INTERCHANGE (H TP80148301) 230/115/'		250	0.60303	105.5501	'GEN335831 1-RIVERBEND UNIT#1'		
FDNS	02ALL	3 11G	ASGI_2010_011	'FROM->TO'	'HITCHLAND INTERCHANGE (H TP80148301) 230/115/'		250	0.60303	104.1112	'GEN336251 1-NINEMILE POINT UNIT#4'		
FDNS	02ALL	3 11G	ASGI_2010_011	'FROM->TO'	'HITCHLAND INTERCHANGE (H TP80148301) 230/115/'		250	0.60303	105.0306	'GEN336251 1-NINEMILE POINT UNIT#4'		
FDNS	02ALL	3 11G	ASGI_2010_011	'FROM->TO'	'HITCHLAND INTERCHANGE (H TP80148301) 230/115/'		250	0.60303	105.2001	'GEN336821 1-GRAND GULF UNIT'		
FDNS	02ALL	3 11G	ASGI_2010_011	'FROM->TO'	'HITCHLAND INTERCHANGE (H TP80148301) 230/115/'		250	0.60303	106.0498	'GEN336821 1-GRAND GULF UNIT'		
FDNS	02ALL	3 11G	ASGI_2010_011	'FROM->TO'	'HITCHLAND INTERCHANGE (H TP80148301) 230/115/'		250	0.60303	104.191	'GEN337041 1-GERALD ANDRUS'		
FDNS	02ALL	3 11G	ASGI_2010_011	'FROM->TO'	'HITCHLAND INTERCHANGE (H TP80148301) 230/115/'		250	0.60303	105.1127	'GEN337041 1-GERALD ANDRUS'		
FDNS	02ALL	3 11G	ASGI_2010_011	'FROM->TO'	'HITCHLAND INTERCHANGE (H TP80148301) 230/115/'		250	0.60303	104.2831	'GEN337652 1-WHITE BLUFF UNIT #1'		
FDNS	02ALL	3 11G	ASGI_2010_011	'FROM->TO'	'HITCHLAND INTERCHANGE (H TP80148301) 230/115/'		250	0.60303	105.1929	'GEN337652 1-WHITE BLUFF UNIT #1'		
FDNS	02ALL	3 11G	ASGI_2010_011	'FROM->TO'	'HITCHLAND INTERCHANGE (H TP80148301) 230/115/'		250	0.60303	104.2117	'GEN337653 1-WHITE BLUFF UNIT #2'		
FDNS	02ALL	3 11G	ASGI_2010_011	'FROM->TO'	'HITCHLAND INTERCHANGE (H TP80148301) 230/115/'		250	0.60303	105.126	'GEN337653 1-WHITE BLUFF UNIT #2'		
FDNS	02ALL	3 11G	ASGI_2010_011	'FROM->TO'	'HITCHLAND INTERCHANGE (H TP80148301) 230/115/'		250	0.60303	104.3244	'GEN337910 1-ARKANSAS NUCLEAR ONE UNIT #1'		
FDNS	02ALL	3 11G	ASGI_2010_011	'FROM->TO'	'HITCHLAND INTERCHANGE (H TP80148301) 230/115/'		250	0.60303	105.221	'GEN337910 1-ARKANSAS NUCLEAR ONE UNIT #1'		
FDNS	02ALL	3 11G	ASGI_2010_011	'FROM->TO'	'HITCHLAND INTERCHANGE (H TP80148301) 230/115/'		250	0.60303	104.6154	'GEN337911 1-ARKANSAS NUCLEAR ONE UNIT #2'		
FDNS	02ALL	3 11G	ASGI_2010_011	'FROM->TO'	'HITCHLAND INTERCHANGE (H TP80148301) 230/115/'		250	0.60303	105.4909	'GEN337911 1-ARKANSAS NUCLEAR ONE UNIT #2'		
FDNS	02ALL	3 11G	ASGI_2010_011	'FROM->TO'	'HITCHLAND INTERCHANGE (H TP80148301) 230/115/'		250	0.60303	104.4157	'GEN338143 1-INDEPENDENCE UNIT #1'		
FDNS	02ALL	3 11G	ASGI_2010_011	'FROM->TO'	'HITCHLAND INTERCHANGE (H TP80148301) 230/115/'		250	0.60303	105.3292	'GEN338143 1-INDEPENDENCE UNIT #1'		
FDNS	02ALL	3 11G	ASGI_2010_011	'FROM->TO'	'HITCHLAND INTERCHANGE (H TP80148301) 230/115/'		250	0.60303	104.4166	'GEN338146 1-INDEPENDENCE UNIT #2'		
FDNS	02ALL	3 11G	ASGI_2010_011	'FROM->TO'	'HITCHLAND INTERCHANGE (H TP80148301) 230/115/'		250	0.60303	105.329	'GEN338146 1-INDEPENDENCE UNIT #2'		
FDNS	02ALL	3 11G	ASGI_2010_011	'FROM->TO'	'HITCHLAND INTERCHANGE (H TP80148301) 230/115/'		250	0.60303	104.2687	'GEN338189 1-LS POWER OSCEOLA UNIT G1'		
FDNS	02ALL	3 11G	ASGI_2010_011	'FROM->TO'	'HITCHLAND INTERCHANGE (H TP80148301) 230/115/'		250	0.60303	105.1965	'GEN338189 1-LS POWER OSCEOLA UNIT G1'		
FDNS	02ALL	3 11G	ASGI_2010_011	'FROM->TO'	'HITCHLAND INTERCHANGE (H TP80148301) 230/115/'		250	0.60303	100.4862	'GEN523087 1-Tri County REC-Texas County Interchange'		
FDNS	02ALL	3 11G	ASGI_2010_011	'FROM->TO'	'HITCHLAND INTERCHANGE (H TP80148301) 230/115/'		250	0.60303	101.4315	'GEN523087 1-Tri County REC-Texas County Interchange'		
FDNS	02ALL	3 11G	ASGI_2010_011	'FROM->TO'	'HITCHLAND INTERCHANGE (H TP80148301) 230/115/'		250	0.60303	105.5185	'GEN523103 1-NOBLE_WND 3115.00'		
FDNS	02ALL	3 11G	ASGI_2010_011	'FROM->TO'	'HITCHLAND INTERCHANGE (H TP80148301) 230/115/'		250	0.60303	106.9072	'GEN523103 1-NOBLE_WND 3115.00'		
FDNS	02ALL	3 11G	ASGI_2010_011	'FROM->TO'	'HITCHLAND INTERCHANGE (H TP80148301) 230/115/'		250	0.60303	99	'GEN523160 1-DWS_FRISCO 3115.00'		
FDNS	02ALL	3 11G	ASGI_2010_011	'FROM->TO'	'HITCHLAND INTERCHANGE (H TP80148301) 230/115/'		250	0.60303	100	'GEN523160 1-DWS_FRISCO 3115.00'		
FDNS	02ALL	3 11G	ASGI_2010_011	'FROM->TO'	'HITCHLAND INTERCHANGE (H TP80148301) 230/115/'		250	0.60303	100.7667	'GEN523277 1-VALERO SUB'		
FDNS	02ALL	3 11G	ASGI_2010_011	'FROM->TO'	'HITCHLAND INTERCHANGE (H TP80148301) 230/115/'		250	0.60303	101.7734	'GEN523277 1-VALERO SUB'		
FDNS	02ALL	3 11G	ASGI_2010_011	'FROM->TO'	'HITCHLAND INTERCHANGE (H TP80148301) 230/115/'		250	0.60303	97.9	'GEN523461 1-BLACKHAWK GEN #1'		
FDNS	02ALL	3 11G	ASGI_2010_011	'FROM->TO'	'HITCHLAND INTERCHANGE (H TP80148301) 230/115/'		250	0.60303	98.9	'GEN523461 1-BLACKHAWK GEN #1'		
FDNS	02ALL	3 11G	ASGI_2010_011	'FROM->TO'	'HITCHLAND INTERCHANGE (H TP80148301) 230/115/'		250	0.60303	97.9	'GEN523462 1-BLACKHAWK GEN #2'		
FDNS	02ALL	3 11G	ASGI_2010_011	'FROM->TO'	'HITCHLAND INTERCHANGE (H TP80148301) 230/115/'		250	0.60303	98.9	'GEN523462 1-BLACKHAWK GEN #2'		
FDNS	02ALL	3 11G	ASGI_2010_011	'FROM->TO'	'HITCHLAND INTERCHANGE (H TP80148301) 230/115/'		250	0.60303	99.6	'GEN523926 1-MAJESTC_WND3115.00'		

SOLUTION GROUP	SCENARIK	SEASON	SOURCE	DIRECTION	MONITORED ELEMENT	COMMON NAME	RATEB	TDF	TC%	LOAD	CONTINGENCY	NAME
FDNS	02ALL	3 11G	ASGI_2010_011	'FROM->TO'	'HITCHLAND INTERCHANGE (H TP80148301) 230/115/'		250	0.60303	104.121	'GEN640010 1-GERALD GENTLEMAN STATION UNIT 1'		
FDNS	02ALL	3 11G	ASGI_2010_011	'FROM->TO'	'HITCHLAND INTERCHANGE (H TP80148301) 230/115/'		250	0.60303	105.1537	'GEN640010 1-GERALD GENTLEMAN STATION UNIT 1'		
FDNS	02ALL	3 11G	ASGI_2010_011	'FROM->TO'	'HITCHLAND INTERCHANGE (H TP80148301) 230/115/'		250	0.60303	104.0294	'GEN645001 1-FORT CALHOUN 1'		
FDNS	02ALL	3 11G	ASGI_2010_011	'FROM->TO'	'HITCHLAND INTERCHANGE (H TP80148301) 230/115/'		250	0.60303	105.0228	'GEN645001 1-FORT CALHOUN 1'		
FNSL-Blow	02G08110	0 11G	ASGI_2010_011		Non Converged		0	0.38722	9999	'DBL-G0847-WO'		
FDNS	02G08110	0 11G	ASGI_2010_011	'FROM->TO'	'Hansford County Switch Station - SPEARMAN INTERCH		160	0.43133	98.2	'HITCHLAND INTERCHANGE (H TP80148301) 230/115/13.2KV TR#'		
FDNS	02G08110	0 11G	ASGI_2010_011	'TO->FROM'	'FINNEY SWITCHING STATION - STEVENSCO 345.00		1052	0.43145	132.1299	'DBL-HIT-G084'		
FDNS	02G08110	0 11G	ASGI_2010_011	'TO->FROM'	'NORTHWEST - TATONGA7 345.00 345KV CKT 1'		1195	0.20349	95.1	'DBL-WOOD-MED'		
FDNS	02G08110	0 11G	ASGI_2010_011	'TO->FROM'	'FINNEY SWITCHING STATION - STEVENSCO 345.00		1052	0.27126	96.4	'DBL-WOOD-MED'		
FDNS	02G08110	2 11G	ASGI_2010_011	'FROM->TO'	'HITCHLAND INTERCHANGE (H TP80148301) 230/115/'		250	0.69388	95.6	'Hansford County Switch Station - SPEARMAN INTERCHANGE 115#'		
FDNS	02G08110	2 11G	ASGI_2010_011	'FROM->TO'	'HITCHLAND INTERCHANGE (H TP80148301) 230/115/'		250	0.69388	95.6	'Hansford County Switch Station - SPEARMAN INTERCHANGE 115#'		
FDNS	02G08110	2 11G	ASGI_2010_011	'FROM->TO'	'Hansford County Switch Station - SPEARMAN INTERCH		160	0.43093	96.8	'HITCHLAND INTERCHANGE (H TP80148301) 230/115/13.2KV TR#'		
FDNS	02G08110	2 11G	ASGI_2010_011	'TO->FROM'	'FINNEY SWITCHING STATION - STEVENSCO 345.00		1052	0.26245	97	'DBL-G0847-WO'		
FDNS	02G08110	2 11G	ASGI_2010_011	'TO->FROM'	'NORTHWEST - TATONGA7 345.00 345KV CKT 1'		1195	0.21256	98	'DBL-WOOD-MED'		
FDNS	02G08110	3 11G	ASGI_2010_011	'FROM->TO'	'HITCHLAND INTERCHANGE (H TP80148301) 230/115/'		250	0.60601	98.4	'G05-17T 345.00 - Hitchland Interchange 345KV CKT 1'		
FDNS	02G08110	3 11G	ASGI_2010_011	'FROM->TO'	'HITCHLAND INTERCHANGE (H TP80148301) 230/115/'		250	0.60601	98.1	'G05-17T 345.00 - Hitchland Interchange 345KV CKT 1'		
FDNS	02G08110	3 11G	ASGI_2010_011	'FROM->TO'	'HITCHLAND INTERCHANGE (H TP80148301) 230/115/'		250	0.69496	97.5	'Hansford County Switch Station - SPEARMAN INTERCHANGE 115#'		
FDNS	02G08110	3 11G	ASGI_2010_011	'FROM->TO'	'HITCHLAND INTERCHANGE (H TP80148301) 230/115/'		250	0.69496	97.7	'Hansford County Switch Station - SPEARMAN INTERCHANGE 115#'		
FDNS	02G08110	3 11G	ASGI_2010_011	'FROM->TO'	'Hansford County Switch Station - SPEARMAN INTERCH		160	0.43073	96.1	'HITCHLAND INTERCHANGE (H TP80148301) 230/115/13.2KV TR#'		
FNSL-Itera	02G0847	0 11G	ASGI_2010_011		Non Converged		0	0.38553	9999	'DBL-G0847-WO'		
FDNS	02G0847	0 11G	ASGI_2010_011	'FROM->TO'	'Hansford County Switch Station - SPEARMAN INTERCH		160	0.43134	98.2	'HITCHLAND INTERCHANGE (H TP80148301) 230/115/13.2KV TR#'		
FDNS	02G0847	0 11G	ASGI_2010_011	'TO->FROM'	'FINNEY SWITCHING STATION - STEVENSCO 345.00		1052	0.43268	128.0221	'DBL-HIT-G084'		
FDNS	02G0847	0 11G	ASGI_2010_011	'TO->FROM'	'NORTHWEST - TATONGA7 345.00 345KV CKT 1'		1195	0.20273	97.1	'DBL-WOOD-MED'		
FDNS	02G0847	0 11G	ASGI_2010_011	'TO->FROM'	'FINNEY SWITCHING STATION - STEVENSCO 345.00		1052	0.27087	98	'DBL-WOOD-MED'		
FDNS	02G0847	2 11G	ASGI_2010_011	'FROM->TO'	'HITCHLAND INTERCHANGE (H TP80148301) 230/115/'		250	0.69391	95.5	'Hansford County Switch Station - SPEARMAN INTERCHANGE 115#'		
FDNS	02G0847	2 11G	ASGI_2010_011	'FROM->TO'	'HITCHLAND INTERCHANGE (H TP80148301) 230/115/'		250	0.69391	95.4	'Hansford County Switch Station - SPEARMAN INTERCHANGE 115#'		
FDNS	02G0847	2 11G	ASGI_2010_011	'FROM->TO'	'Hansford County Switch Station - SPEARMAN INTERCH		160	0.43093	96.8	'HITCHLAND INTERCHANGE (H TP80148301) 230/115/13.2KV TR#'		
FDNS	02G0847	2 11G	ASGI_2010_011	'TO->FROM'	'NORTHWEST - TATONGA7 345.00 345KV CKT 1'		1195	0.21218	100	'DBL-WOOD-MED'		
FNSL	02G0847	2 11G	ASGI_2010_011	'TO->FROM'	'FINNEY SWITCHING STATION - STEVENSCO 345.00		1052	0.26181	99.7	'DBL-G0847-WO'		
FDNS	02G0847	3 11G	ASGI_2010_011	'FROM->TO'	'HITCHLAND INTERCHANGE (H TP80148301) 230/115/'		250	0.60606	98.1	'G05-17T 345.00 - Hitchland Interchange 345KV CKT 1'		
FDNS	02G0847	3 11G	ASGI_2010_011	'FROM->TO'	'HITCHLAND INTERCHANGE (H TP80148301) 230/115/'		250	0.60606	97.7	'G05-17T 345.00 - Hitchland Interchange 345KV CKT 1'		
FDNS	02G0847	3 11G	ASGI_2010_011	'FROM->TO'	'HITCHLAND INTERCHANGE (H TP80148301) 230/115/'		250	0.69498	97.4	'Hansford County Switch Station - SPEARMAN INTERCHANGE 115#'		
FDNS	02G0847	3 11G	ASGI_2010_011	'FROM->TO'	'HITCHLAND INTERCHANGE (H TP80148301) 230/115/'		250	0.69498	97.6	'Hansford County Switch Station - SPEARMAN INTERCHANGE 115#'		
FDNS	02G0847	3 11G	ASGI_2010_011	'FROM->TO'	'Hansford County Switch Station - SPEARMAN INTERCH		160	0.43074	96.1	'HITCHLAND INTERCHANGE (H TP80148301) 230/115/13.2KV TR#'		
FDNS	02G1007	0 11G	ASGI_2010_011	'FROM->TO'	'Hansford County Switch Station - SPEARMAN INTERCH		160	0.43137	97.5	'HITCHLAND INTERCHANGE (H TP80148301) 230/115/13.2KV TR#'		
FDNS	02G1007	0 11G	ASGI_2010_011	'TO->FROM'	'FINNEY SWITCHING STATION - STEVENSCO 345.00		1052	0.43236	128.8406	'DBL-HIT-G084'		
FNSL-Itera	02G1007	0 11G	ASGI_2010_011		Non Converged		1052	0.21039	77.23053	'FINNEY SWITCHING STATION - STEVENSCO 345.00 345KV CK'		
FNSL-Itera	02G1007	0 11G	ASGI_2010_011		Non Converged		0	0.38804	9999	'DBL-G0847-WO'		
FDNS	02G1007	2 11G	ASGI_2010_011	'FROM->TO'	'HITCHLAND INTERCHANGE (H TP80148301) 230/115/'		250	0.69398	96.5	'Hansford County Switch Station - SPEARMAN INTERCHANGE 115#'		
FDNS	02G1007	2 11G	ASGI_2010_011	'FROM->TO'	'HITCHLAND INTERCHANGE (H TP80148301) 230/115/'		250	0.69398	96.4	'Hansford County Switch Station - SPEARMAN INTERCHANGE 115#'		
FDNS	02G1007	2 11G	ASGI_2010_011	'FROM->TO'	'Hansford County Switch Station - SPEARMAN INTERCH		160	0.43096	96.1	'HITCHLAND INTERCHANGE (H TP80148301) 230/115/13.2KV TR#'		
FDNS	02G1007	2 11G	ASGI_2010_011	'TO->FROM'	'NORTHWEST - TATONGA7 345.00 345KV CKT 1'		1195	0.21299	96.9	'DBL-WOOD-MED'		
FNSL-Itera	02G1007	2 11G	ASGI_2010_011		Non Converged		0	0.28775	9999	'DBL-G0847-WO'		
FDNS	02G1007	3 11G	ASGI_2010_011	'FROM->TO'	'HITCHLAND INTERCHANGE (H TP80148301) 230/115/'		250	0.60581	100.5505	'G05-17T 345.00 - Hitchland Interchange 345KV CKT 1'		
FDNS	02G1007	3 11G	ASGI_2010_011	'FROM->TO'	'HITCHLAND INTERCHANGE (H TP80148301) 230/115/'		250	0.60581	100.2829	'G05-17T 345.00 - Hitchland Interchange 345KV CKT 1'		
FDNS	02G1007	3 11G	ASGI_2010_011	'FROM->TO'	'HITCHLAND INTERCHANGE (H TP80148301) 230/115/'		250	0.66863	96.3	'DWS_FRISCO 3115.00 - SHERMAN COUNTY TAP 115KV CKT 1'		
FDNS	02G1007	3 11G	ASGI_2010_011	'FROM->TO'	'HITCHLAND INTERCHANGE (H TP80148301) 230/115/'		250	0.66863	96.2	'DWS_FRISCO 3115.00 - SHERMAN COUNTY TAP 115KV CKT 1'		
FDNS	02G1007	3 11G	ASGI_2010_011	'FROM->TO'	'HITCHLAND INTERCHANGE (H TP80148301) 230/115/'		250	0.69488	98.3	'Hansford County Switch Station - SPEARMAN INTERCHANGE 115#'		
FDNS	02G1007	3 11G	ASGI_2010_011	'FROM->TO'	'HITCHLAND INTERCHANGE (H TP80148301) 230/115/'		250	0.69488	98.5	'Hansford County Switch Station - SPEARMAN INTERCHANGE 115#'		
FDNS	02G1007	3 11G	ASGI_2010_011	'FROM->TO'	'Hansford County Switch Station - SPEARMAN INTERCH		160	0.43077	95.4	'HITCHLAND INTERCHANGE (H TP80148301) 230/115/13.2KV TR#'		
FNSL-Itera	02G1014	0 11G	ASGI_2010_011		Non Converged		0	0.38699	9999	'DBL-G0847-WO'		
FDNS	02G1014	0 11G	ASGI_2010_011	'FROM->TO'	'Hansford County Switch Station - SPEARMAN INTERCH		160	0.43134	98.2	'HITCHLAND INTERCHANGE (H TP80148301) 230/115/13.2KV TR#'		
FDNS	02G1014	0 11G	ASGI_2010_011	'TO->FROM'	'FINNEY SWITCHING STATION - STEVENSCO 345.00		1052	0.43124	133.3729	'DBL-HIT-G084'		
FDNS	02G1014	0 11G	ASGI_2010_011	'TO->FROM'	'NORTHWEST - TATONGA7 345.00 345KV CKT 1'		1195	0.20338	95.4	'DBL-WOOD-MED'		
FDNS	02G1014	0 11G	ASGI_2010_011	'TO->FROM'	'FINNEY SWITCHING STATION - STEVENSCO 345.00		1052	0.27116	96.9	'DBL-WOOD-MED'		
FDNS	02G1014	2 11G	ASGI_2010_011	'FROM->TO'	'HITCHLAND INTERCHANGE (H TP80148301) 230/115/'		250	0.69389	95.3	'Hansford County Switch Station - SPEARMAN INTERCHANGE 115#'		
FDNS	02G1014	2 11G	ASGI_2010_011	'FROM->TO'	'HITCHLAND INTERCHANGE (H TP80148301) 230/115/'		250	0.69389	95.4	'Hansford County Switch Station - SPEARMAN INTERCHANGE 115#'		
FDNS	02G1014	2 11G	ASGI_2010_011	'FROM->TO'	'Hansford County Switch Station - SPEARMAN INTERCH		160	0.43093	96.8	'HITCHLAND INTERCHANGE (H TP80148301) 230/115/13.2KV TR#'		
FDNS	02G1014	2 11G	ASGI_2010_011	'TO->FROM'	'FINNEY SWITCHING STATION - STEVENSCO 345.00		1052	0.26234	97.6	'DBL-G0847-WO'		
FDNS	02G1014	2 11G	ASGI_2010_011	'TO->FROM'	'NORTHWEST - TATONGA7 345.00 345KV CKT 1'		1195	0.21244	98.3	'DBL-WOOD-MED'		
FDNS	02G1014	3 11G	ASGI_2010_011	'FROM->TO'	'HITCHLAND INTERCHANGE (H TP80148301) 230/115/'		250	0.60602	98	'G05-17T 345.00 - Hitchland Interchange 345KV CKT 1'		
FDNS	02G1014	3 11G	ASGI_2010_011	'FROM->TO'	'HITCHLAND INTERCHANGE (H TP80148301) 230/115/'		250	0.60602	97.9	'G05-17T 345.00 - Hitchland Interchange 345KV CKT 1'		
FDNS	02G1014	3 11G	ASGI_2010_011	'FROM->TO'	'HITCHLAND INTERCHANGE (H TP80148301) 230/115/'		250	0.69497	97.5	'Hansford County Switch Station - SPEARMAN INTERCHANGE 115#'		
FDNS	02G1014	3 11G	ASGI_2010_011	'FROM->TO'	'HITCHLAND INTERCHANGE (H TP80148301) 230/115/'		250	0.69497	97.7	'Hansford County Switch Station - SPEARMAN INTERCHANGE 115#'		
FDNS	02G1014	3 11G	ASGI_2010_011	'FROM->TO'	'Hansford County Switch Station - SPEARMAN INTERCH		160	0.43074	96	'HITCHLAND INTERCHANGE (H TP80148301) 230/115/13.2KV TR#'		
FDNS	2	0 11G	ASGI_2010_011	'FROM->TO'	'Hansford County Switch Station - SPEARMAN INTERCH		160	0.43134	98	'HITCHLAND INTERCHANGE (H TP80148301) 230/115/13.2KV TR#'		
FDNS	2	0 11G	ASGI_2010_011	'TO->FROM'	'FINNEY SWITCHING STATION - STEVENSCO 345.00		1052	0.43257	128.0433	'DBL-HIT-G084'		

SOLUTION GROUP	SCENARI	SEASON	SOURCE	DIRECTION	MONITORED ELEMENT	COMMON NAME	RATEB	TDF	TC%	LOAD	CONTINGENCY	NAME
FNSL-Itera	2	0 11G	ASGI_2010_011		Non Converged		1052	0.2105	76.82405	'FINNEY SWITCHING STATION - STEVENSCO	345.00	345KV CKT
FNSL-Blow	2	0 11G	ASGI_2010_011		Non Converged		0	0.38823	9999	'DBL-G0847-WO'		
FDNS	2	2 11G	ASGI_2010_011	'FROM->TO'	'HITCHLAND INTERCHANGE (H TP80148301) 230/115/'		250	0.69384	96	'Hansford County Switch Station - SPEARMAN INTERCHANGE 115'		
FDNS	2	2 11G	ASGI_2010_011	'FROM->TO'	'HITCHLAND INTERCHANGE (H TP80148301) 230/115/'		250	0.69384	96	'Hansford County Switch Station - SPEARMAN INTERCHANGE 115'		
FDNS	2	2 11G	ASGI_2010_011	'FROM->TO'	'Hansford County Switch Station - SPEARMAN INTERCH		160	0.43093	96.6	'HITCHLAND INTERCHANGE (H TP80148301) 230/115/13.2KV TR'		
FDNS	2	2 11G	ASGI_2010_011	'TO->FROM'	'NORTHWEST - TATONGA7 345.00 345KV CKT 1'		1195	0.21312	96.5	'DBL-WOOD-MED'		
FNSL-Itera	2	2 11G	ASGI_2010_011		Non Converged		0	0.2879	9999	'DBL-G0847-WO'		
FDNS	2	3 11G	ASGI_2010_011	'FROM->TO'	'HITCHLAND INTERCHANGE (H TP80148301) 230/115/'		250	0.60592	99.3	'G05-17T 345.00 - Hitchland Interchange 345KV CKT 1'		
FDNS	2	3 11G	ASGI_2010_011	'FROM->TO'	'HITCHLAND INTERCHANGE (H TP80148301) 230/115/'		250	0.60592	99.1	'G05-17T 345.00 - Hitchland Interchange 345KV CKT 1'		
FDNS	2	3 11G	ASGI_2010_011	'FROM->TO'	'HITCHLAND INTERCHANGE (H TP80148301) 230/115/'		250	0.66871	95.3	'DWS_FRISCO 3115.00 - SHERMAN COUNTY TAP 115KV CKT 1'		
FDNS	2	3 11G	ASGI_2010_011	'FROM->TO'	'HITCHLAND INTERCHANGE (H TP80148301) 230/115/'		250	0.66871	95.2	'DWS_FRISCO 3115.00 - SHERMAN COUNTY TAP 115KV CKT 1'		
FDNS	2	3 11G	ASGI_2010_011	'FROM->TO'	'HITCHLAND INTERCHANGE (H TP80148301) 230/115/'		250	0.69492	98.2	'Hansford County Switch Station - SPEARMAN INTERCHANGE 115'		
FDNS	2	3 11G	ASGI_2010_011	'FROM->TO'	'HITCHLAND INTERCHANGE (H TP80148301) 230/115/'		250	0.69492	98.2	'Hansford County Switch Station - SPEARMAN INTERCHANGE 115'		
FDNS	2	3 11G	ASGI_2010_011	'FROM->TO'	'Hansford County Switch Station - SPEARMAN INTERCH		160	0.43074	95.9	'HITCHLAND INTERCHANGE (H TP80148301) 230/115/13.2KV TR'		
FNSL-Itera 02ALL	0	0 11G	ASGI_2010_011		Non Converged		1052	0.14363	76.82405	'FINNEY SWITCHING STATION - STEVENSCO	345.00	345KV CKT
FNSL-Itera 02ALL	0	0 11G	ASGI_2010_011		Non Converged		0	0.12686	9999	'SPP-SWPS-03'		
FNSL-Itera 02ALL	0	0 11G	ASGI_2010_011		Non Converged		441	0.11739	57.58744	'STATELINE INTERCHANGE - STLN-DEMARC6230.00 230KV CKT		
FNSL-Itera 02ALL	0	0 11G	ASGI_2010_011		Non Converged		0	0.08277	9999	'SPP-SWPS-02'		
FNSL-Itera 02ALL	0	0 11G	ASGI_2010_011		Non Converged		0	0.08061	9999	'ATC_B2_8E2_G'		
FNSL-Itera 02ALL	0	0 11G	ASGI_2010_011		Non Converged		0	0.07821	9999	'050 1'		
FNSL-Itera 02ALL	0	0 11G	ASGI_2010_011		Non Converged		0	0.07549	9999	'ATC_B2_8E2'		
FNSL-Itera 02ALL	0	0 11G	ASGI_2010_011		Non Converged		0	0.07382	9999	'050 2'		
FNSL-Itera 02ALL	0	0 11G	ASGI_2010_011		Non Converged		441	0.07141	57.61415	'STATELINE INTERCHANGE - STLN-DEMARC6230.00 230KV CKT		
FNSL-Itera 02ALL	0	0 11G	ASGI_2010_011		Non Converged		0	0.05483	9999	'ATC_B2_8E2_G'		
FNSL-Blow 02ALL	0	0 11G	ASGI_2010_011		Non Converged		0	0.0529	9999	'050 1'		
FNSL-Itera 02ALL	0	0 11G	ASGI_2010_011		Non Converged		0	0.05103	9999	'ATC_B2_8E2'		
FNSL-Itera 02ALL	0	0 11G	ASGI_2010_011		Non Converged		0	0.04406	9999	'SPP-SWPS-02'		
FNSL-Itera 02ALL	0	0 11G	ASGI_2010_011		Non Converged		441	0.04137	57.58744	'STATELINE INTERCHANGE - STLN-DEMARC6230.00 230KV CKT		
FNSL-Itera 02ALL	0	0 11G	ASGI_2010_011		Non Converged		1052	0.03101	77.23053	'FINNEY SWITCHING STATION - STEVENSCO	345.00	345KV CKT
FNSL-Itera 02ALL	0	0 11G	ASGI_2010_011		Non Converged		0	0.02895	9999	'ATC_B2_8E2'		
FNSL-Itera 02ALL	0	0 11G	ASGI_2010_011		Non Converged		1052	0.02625	76.82405	'FINNEY SWITCHING STATION - STEVENSCO	345.00	345KV CKT
FNSL-Itera 02ALL	0	0 11G	ASGI_2010_011		Non Converged		0	0.02318	9999	'ATC_B2_8E2_G'		
FNSL-Itera 02ALL	0	0 11G	ASGI_2010_011		Non Converged		441	0.02212	56.03129	'STLN-DEMARC6230.00 - SWEETWT6	230.00	230KV CKT 1'
FNSL-Itera 02ALL	0	0 11G	ASGI_2010_011		Non Converged		0	0.02181	9999	'ATC_B2_8E2'		
FNSL-Blow 02ALL	0	0 11G	ASGI_2010_011		Non Converged		1052	0.20232	97.33807	'FINNEY SWITCHING STATION - STEVENSCO	345.00	345KV CKT
FNSL-Blow 02ALL	0	0 11G	ASGI_2010_011		Non Converged		0	0.39621	9999	'DBL-HIT-G084'		
FNSL-Blow 02ALL	0	0 11G	ASGI_2010_011		Non Converged		0	0.37465	9999	'DBL-G0847-WO'		
FNSL-Itera 02ALL	0	0 11G	ASGI_2010_011		Non Converged		0	0.04149	9999	'SPP-SWPS-T53'		
FNSL-Itera 02ALL	2	2 11G	ASGI_2010_011		Non Converged		1052	0.17644	82.65054	'FINNEY SWITCHING STATION - STEVENSCO	345.00	345KV CKT
FNSL-Itera 02ALL	2	2 11G	ASGI_2010_011		Non Converged		0	0.27726	9999	'DBL-G0847-WO'		
FNSL-Blow 02G08110	0	0 11G	ASGI_2010_011		Non Converged		0	0.38722	9999	'DBL-G0847-WO'		
FNSL-Itera 02G08110	0	0 11G	ASGI_2010_011		Non Converged		0	0.12673	9999	'SPP-SWPS-02'		
FNSL-Itera 02G08110	0	0 11G	ASGI_2010_011		Non Converged		441	0.06337	56.82947	'STLN-DEMARC6230.00 - SWEETWT6	230.00	230KV CKT 1'
FNSL-Itera 02G08110	0	0 11G	ASGI_2010_011		Non Converged		441	0.06337	57.15012	'STATELINE INTERCHANGE - STLN-DEMARC6230.00 230KV CKT		
FNSL-Itera 02G08110	3	3 11G	ASGI_2010_011		Non Converged		0	0.09478	9999	'SPP-SWPS-03'		
FNSL-Itera 02G0847	0	0 11G	ASGI_2010_011		Non Converged		441	0.06334	57.61415	'STATELINE INTERCHANGE - STLN-DEMARC6230.00 230KV CKT		
FNSL-Itera 02G0847	0	0 11G	ASGI_2010_011		Non Converged		0	0.38553	9999	'DBL-G0847-WO'		
FNSL-Itera 02G0847	0	0 11G	ASGI_2010_011		Non Converged		0	0.12667	9999	'SPP-SWPS-02'		
FNSL-Itera 02G0847	0	0 11G	ASGI_2010_011		Non Converged		441	0.06334	57.29366	'STLN-DEMARC6230.00 - SWEETWT6	230.00	230KV CKT 1'
FNSL-Itera 02G0847	0	0 11G	ASGI_2010_011		Non Converged		351	0.05447	82.03278	'GRAPEVINE INTERCHANGE - NICHOLS STATION 230KV CKT 1'		
FNSL-Itera 02G0847	3	3 11G	ASGI_2010_011		Non Converged		0	0.09474	9999	'SPP-SWPS-03'		
FNSL-Itera 02G1007	0	0 11G	ASGI_2010_011		Non Converged		441	0.06339	56.55862	'STLN-DEMARC6230.00 - SWEETWT6	230.00	230KV CKT 1'
FNSL-Itera 02G1007	0	0 11G	ASGI_2010_011		Non Converged		441	0.06339	56.87944	'STATELINE INTERCHANGE - STLN-DEMARC6230.00 230KV CKT		
FNSL-Itera 02G1007	0	0 11G	ASGI_2010_011		Non Converged		1052	0.21039	77.23053	'FINNEY SWITCHING STATION - STEVENSCO	345.00	345KV CKT
FNSL-Itera 02G1007	0	0 11G	ASGI_2010_011		Non Converged		0	0.38804	9999	'DBL-G0847-WO'		
FNSL-Itera 02G1007	0	0 11G	ASGI_2010_011		Non Converged		0	0.12677	9999	'SPP-SWPS-02'		
FNSL-Itera 02G1007	2	2 11G	ASGI_2010_011		Non Converged		0	0.28775	9999	'DBL-G0847-WO'		
FNSL-Itera 02G1007	3	3 11G	ASGI_2010_011		Non Converged		0	0.09478	9999	'SPP-SWPS-03'		
FNSL-Itera 02G1014	0	0 11G	ASGI_2010_011		Non Converged		0	0.38699	9999	'DBL-G0847-WO'		
FNSL-Itera 02G1014	0	0 11G	ASGI_2010_011		Non Converged		0	0.12665	9999	'SPP-SWPS-02'		
FNSL-Itera 02G1014	0	0 11G	ASGI_2010_011		Non Converged		441	0.06332	57.2667	'STLN-DEMARC6230.00 - SWEETWT6	230.00	230KV CKT 1'
FNSL-Itera 02G1014	0	0 11G	ASGI_2010_011		Non Converged		351	0.05446	81.98898	'GRAPEVINE INTERCHANGE - NICHOLS STATION 230KV CKT 1'		
FNSL-Itera 02G1014	0	0 11G	ASGI_2010_011		Non Converged		441	0.06332	57.58744	'STATELINE INTERCHANGE - STLN-DEMARC6230.00 230KV CKT		
FNSL-Itera 02G1014	3	3 11G	ASGI_2010_011		Non Converged		0	0.09472	9999	'SPP-SWPS-03'		
FNSL-Itera	2	0 11G	ASGI_2010_011		Non Converged		441	0.06345	56.03129	'STLN-DEMARC6230.00 - SWEETWT6	230.00	230KV CKT 1'
FNSL-Itera	2	0 11G	ASGI_2010_011		Non Converged		441	0.06345	56.34883	'STATELINE INTERCHANGE - STLN-DEMARC6230.00 230KV CKT		
FNSL-Itera	2	0 11G	ASGI_2010_011		Non Converged		1052	0.2105	76.82405	'FINNEY SWITCHING STATION - STEVENSCO	345.00	345KV CKT

SOLUTION GROUP	SCENARI	SEASON	SOURCE	DIRECTION	MONITORED ELEMENT	COMMON NAME	RATEB	TDF	TC%	LOAD	CONTINGENCY	NAME
FNSL-Blow	2	0 11G	ASGL_2010_011			Non Converged	0	0.38823	9999	'DBL-G0847-WO'		
FNSL-Itera	2	0 11G	ASGL_2010_011			Non Converged	0	0.1269	9999	'SPP-SWPS-02'		
FNSL-Itera	2	2 11G	ASGL_2010_011			Non Converged	0	0.2879	9999	'DBL-G0847-WO'		
FNSL-Itera	2	3 11G	ASGL_2010_011			Non Converged	0	0.09489	9999	'SPP-SWPS-03'		
FNSL-Blow 03ALL		0 11G	ASGL_2010_011			Non Converged	0	0.17272	9999	'DBL-MEDLO-WI'		
FNSL-Itera	6	0 11G	ASGL_2010_011			Non Converged	0	0.12224	9999	'SPP-SWPS-03'		
FDNS	9	0 11G	G06_044N02	'TO->FROM'	'KELLY - MADISONCO	230.00 230KV CKT 1'	200	0.76725	127.2138	'BASE CASE'		
FDNS	9	0 11G	G06_044N02	'TO->FROM'	'FT RANDAL - MADISONCO	230.00 230KV CKT 1'	200	0.98857	162.2827	'KELLY - MADISONCO 230.00 230KV CKT 1'		
FDNS	9	0 11G	G06_044N02	'TO->FROM'	'KELLY - MADISONCO	230.00 230KV CKT 1'	200	0.76725	125.7	'BLOOMFIELD - G07-11N9 115.00 115KV CKT 1'		
FDNS	9	0 11G	G06_044N02	'TO->FROM'	'KELLY - MADISONCO	230.00 230KV CKT 1'	200	0.76803	124.9238	'AINSWORTH - AINSWORTH 115KV CKT 1'		
FDNS	9	0 11G	G06_044N02	'TO->FROM'	'KELLY - MADISONCO	230.00 230KV CKT 1'	200	0.75179	130.2414	'COLUMEAST - NW68TH & HOLDREGE 345KV CKT 1'		
FDNS	9	0 11G	G06_044N02	'TO->FROM'	'KELLY - MADISONCO	230.00 230KV CKT 1'	200	0.7587	124.6424	'COLUMEAST 230/115KV TRANSFORMER CKT 1'		
FDNS	9	0 11G	G06_044N02	'TO->FROM'	'KELLY - MADISONCO	230.00 230KV CKT 1'	200	0.7587	124.6447	'COLUMEAST - KELLY 230KV CKT 1'		
FDNS	9	0 11G	G06_044N02	'TO->FROM'	'KELLY - MADISONCO	230.00 230KV CKT 1'	200	0.744	130.3588	'COLUMWEST - GRAND ISLAND 230KV CKT 1'		
FDNS	9	0 11G	G06_044N02	'TO->FROM'	'KELLY - MADISONCO	230.00 230KV CKT 1'	200	0.72635	119.7162	'KELLY - SHELL CREEK 230KV CKT 1'		
FDNS	9	0 11G	G06_044N02	'TO->FROM'	'KELLY - MADISONCO	230.00 230KV CKT 1'	200	0.76013	125.0899	'COLUMBUS - KELLY 115KV CKT 1'		
FDNS	9	0 11G	G06_044N02	'TO->FROM'	'KELLY - MADISONCO	230.00 230KV CKT 1'	200	0.76549	125.6072	'COLUMBUS - SCHUYLER 115KV CKT 1'		
FDNS	9	0 11G	G06_044N02	'TO->FROM'	'KELLY - MADISONCO	230.00 230KV CKT 1'	200	0.74968	117.7065	'HOSKINS - SHELL CREEK 345KV CKT 1'		
FDNS	9	0 11G	G06_044N02	'TO->FROM'	'KELLY - MADISONCO	230.00 230KV CKT 1'	200	0.76682	125.4529	'NELIGH - PETERSBURG 115KV CKT 1'		
FDNS	9	0 11G	G06_044N02	'TO->FROM'	'KELLY - MADISONCO	230.00 230KV CKT 1'	200	0.72635	119.7088	'SHELL CREEK 345/230KV TRANSFORMER CKT 1'		
FDNS	9	0 11G	G06_044N02	'TO->FROM'	'KELLY - MADISONCO	230.00 230KV CKT 1'	200	0.76746	125.0806	'ATCHSNT3 345.00 - BOONEVILLE 345KV CKT 1'		
FDNS	9	0 11G	G06_044N02	'TO->FROM'	'KELLY - MADISONCO	230.00 230KV CKT 1'	200	0.76852	120.8917	'RAUN - SIOUX CITY 345KV CKT 1'		
FDNS	9	0 11G	G06_044N02	'TO->FROM'	'KELLY - MADISONCO	230.00 230KV CKT 1'	200	0.7681	123.2956	'NUNDRWD - WAYSIDE 230KV CKT 1'		
FDNS	9	0 11G	G06_044N02	'TO->FROM'	'KELLY - MADISONCO	230.00 230KV CKT 1'	200	0.76784	123.7347	'STEGALL - WAYSIDE 230KV CKT 1'		
FDNS	9	0 11G	G06_044N02	'TO->FROM'	'KELLY - MADISONCO	230.00 230KV CKT 1'	200	0.76878	129.2914	'UTICA JCT - VFODNES 230KV CKT 1'		
FDNS	9	0 11G	G06_044N02	'TO->FROM'	'KELLY - MADISONCO	230.00 230KV CKT 1'	200	0.77655	135.694	'FT RANDAL - UTICA JCT 230KV CKT 1'		
FDNS	9	0 11G	G06_044N02	'TO->FROM'	'KELLY - MADISONCO	230.00 230KV CKT 1'	200	0.77407	133.218	'FT RANDAL - SIOUX CITY 230KV CKT 1'		
FDNS	9	0 11G	G06_044N02	'TO->FROM'	'KELLY - MADISONCO	230.00 230KV CKT 1'	200	0.76785	124.0883	'GAVINS POINT - YANKON JCT 115KV CKT 1'		
FDNS	9	0 11G	G06_044N02	'TO->FROM'	'KELLY - MADISONCO	230.00 230KV CKT 1'	200	0.76954	129.3441	'RASMUSN - UTICA JCT 230KV CKT 1'		
FDNS	9	0 11G	G06_044N02	'TO->FROM'	'KELLY - MADISONCO	230.00 230KV CKT 1'	200	0.76954	128.7668	'RASMUSN - SIOUX CITY 230KV CKT 1'		
FDNS	9	0 11G	G06_044N02	'TO->FROM'	'KELLY - MADISONCO	230.00 230KV CKT 1'	200	0.98857	160.2117	'FT RANDAL - MADISONCO 230.00 230KV CKT 1'		
FDNS	9	0 11G	G06_044N02	'TO->FROM'	'KELLY - MADISONCO	230.00 230KV CKT 1'	200	0.76725	125.7	'G07-11N9 115.00 115/34.5KV TRANSFORMER CKT 1'		
FDNS	9	0 11G	G06_044N02	'TO->FROM'	'KELLY - MADISONCO	230.00 230KV CKT 1'	200	0.76725	125.5	'BLOOMFIELD 115/34.5KV TRANSFORMER CKT 1'		
FDNS	9	0 11G	G06_044N02	'TO->FROM'	'KELLY - MADISONCO	230.00 230KV CKT 1'	200	0.76727	125.2237	'BLOOMFIELD - GAVINS POINT 115KV CKT 1'		
FDNS	9	0 11G	G06_044N02	'TO->FROM'	'KELLY - MADISONCO	230.00 230KV CKT 1'	200	0.76013	125.0901	'KELLY (KLYT1REG) 230/115/13.2KV TRANSFORMER CKT 1'		
FDNS	9	0 11G	G06_044N02	'TO->FROM'	'KELLY - MADISONCO	230.00 230KV CKT 1'	200	0.76746	125.4561	'ATCHSNT3 345.00 - COOPER 345KV CKT 1'		
FDNS	9	0 11G	G06_044N02	'TO->FROM'	'KELLY - MADISONCO	230.00 230KV CKT 1'	200	0.76725	125.7	'GERALD GENTLEMAN STATION 230/23.0KV TRANSFORMER CK		
FDNS	9	0 11G	G06_044N02	'TO->FROM'	'KELLY - MADISONCO	230.00 230KV CKT 1'	200	0.7674	128.8223	'KEYSTONE - SIDNEY 345KV CKT 1'		
FDNS	9	0 11G	G06_044N02	'TO->FROM'	'KELLY - MADISONCO	230.00 230KV CKT 1'	200	0.76943	125.0344	'RAUN - SUB 3451 FT CAL 345KV CKT 1'		
FDNS	9	0 11G	G06_044N02	'TO->FROM'	'KELLY - MADISONCO	230.00 230KV CKT 1'	200	0.76962	125.6156	'FT THOMPSON - GRAND ISLAND 345KV CKT 1'		
FDNS	9	0 11G	G06_044N02	'TO->FROM'	'KELLY - MADISONCO	230.00 230KV CKT 1'	200	0.76725	132.1	'COUNCIL BLUFFS 345/24.0KV TRANSFORMER CKT 1'		
FDNS	9	0 11G	G06_044N02	'TO->FROM'	'KELLY - MADISONCO	230.00 230KV CKT 1'	200	0.76725	132.6	'COUNCIL BLUFFS 345/26.0KV TRANSFORMER CKT 1'		
FDNS	9	0 11G	G06_044N02	'TO->FROM'	'KELLY - MADISONCO	230.00 230KV CKT 1'	200	0.7667	125.1144	'LAKEFIELD 3 - RAUN 345KV CKT 1'		
FDNS	9	0 11G	G06_044N02	'TO->FROM'	'KELLY - MADISONCO	230.00 230KV CKT 1'	200	0.76725	123.7495	'FT RANDAL 230/13.8KV TRANSFORMER CKT 1'		
FDNS	9	0 11G	G06_044N02	'TO->FROM'	'KELLY - MADISONCO	230.00 230KV CKT 1'	200	0.76725	125.4987	'FT RANDAL 230/13.8KV TRANSFORMER CKT 1'		
FDNS	9	0 11G	G06_044N02	'TO->FROM'	'KELLY - MADISONCO	230.00 230KV CKT 1'	200	0.76725	124.9019	'FT RANDAL 115/13.8KV TRANSFORMER CKT 1'		
FDNS	9	0 11G	G06_044N02	'TO->FROM'	'KELLY - MADISONCO	230.00 230KV CKT 1'	200	0.76725	128.7427	'LELAND OLDS 345/20.0KV TRANSFORMER CKT 1'		
FDNS	9	0 11G	G06_044N02	'TO->FROM'	'KELLY - MADISONCO	230.00 230KV CKT 1'	200	0.76013	125.0899	'TRF-KELLY'		
FDNS	9	0 11G	G06_044N02	'TO->FROM'	'KELLY - MADISONCO	230.00 230KV CKT 1'	200	0.77681	136.063	'DAK02WAPAB2'		
FDNS	9	0 11G	G06_044N02	'TO->FROM'	'KELLY - MADISONCO	230.00 230KV CKT 1'	200	0.76725	129.0146	'GEN532751 1-WOLF CREEK GENERATING STATION UNIT 1'		
FDNS	9	0 11G	G06_044N02	'TO->FROM'	'KELLY - MADISONCO	230.00 230KV CKT 1'	200	0.76725	129.7298	'GEN640009 1-COOPER NUCLEAR STATION'		
FDNS	9	0 11G	G06_044N02	'TO->FROM'	'KELLY - MADISONCO	230.00 230KV CKT 1'	200	0.76725	129.3146	'GEN640028 1-COLUMCOGENERATION'		
FDNS	9	0 11G	G06_044N02	'TO->FROM'	'KELLY - MADISONCO	230.00 230KV CKT 1'	200	0.76725	129.199	'GEN645011 1-NEBRASKA CITY 1'		
FDNS	9	0 11G	G06_044N02	'TO->FROM'	'KELLY - MADISONCO	230.00 230KV CKT 1'	200	0.76725	129.5189	'GEN645012 2-NEBRASKA CITY 2'		
FDNS	9	0 11G	G06_044N02	'TO->FROM'	'KELLY - MADISONCO	230.00 230KV CKT 1'	200	0.76725	127.2138	'BASE CASE'		
FDNS	9	0 11G	G06_044N02	'TO->FROM'	'FT RANDAL - MADISONCO	230.00 230KV CKT 1'	200	0.98857	162.2827	'KELLY - MADISONCO 230.00 230KV CKT 1'		
FDNS	9	0 11G	G06_044N02	'TO->FROM'	'KELLY - MADISONCO	230.00 230KV CKT 1'	200	0.76725	125.7	'BLOOMFIELD - G07-11N9 115.00 115KV CKT 1'		
FDNS	9	0 11G	G06_044N02	'TO->FROM'	'KELLY - MADISONCO	230.00 230KV CKT 1'	200	0.76803	124.9238	'AINSWORTH - AINSWORTH 115KV CKT 1'		
FDNS	9	0 11G	G06_044N02	'TO->FROM'	'KELLY - MADISONCO	230.00 230KV CKT 1'	200	0.75179	130.2414	'COLUMEAST - NW68TH & HOLDREGE 345KV CKT 1'		
FDNS	9	0 11G	G06_044N02	'TO->FROM'	'KELLY - MADISONCO	230.00 230KV CKT 1'	200	0.7587	124.6424	'COLUMEAST 230/115KV TRANSFORMER CKT 1'		
FDNS	9	0 11G	G06_044N02	'TO->FROM'	'KELLY - MADISONCO	230.00 230KV CKT 1'	200	0.7587	124.6447	'COLUMEAST - KELLY 230KV CKT 1'		
FDNS	9	0 11G	G06_044N02	'TO->FROM'	'KELLY - MADISONCO	230.00 230KV CKT 1'	200	0.744	130.3588	'COLUMWEST - GRAND ISLAND 230KV CKT 1'		
FDNS	9	0 11G	G06_044N02	'TO->FROM'	'KELLY - MADISONCO	230.00 230KV CKT 1'	200	0.72635	119.7162	'KELLY - SHELL CREEK 230KV CKT 1'		
FDNS	9	0 11G	G06_044N02	'TO->FROM'	'KELLY - MADISONCO	230.00 230KV CKT 1'	200	0.76013	125.0899	'COLUMBUS - KELLY 115KV CKT 1'		
FDNS	9	0 11G	G06_044N02	'TO->FROM'	'KELLY - MADISONCO	230.00 230KV CKT 1'	200	0.76549	125.6072	'COLUMBUS - SCHUYLER 115KV CKT 1'		
FDNS	9	0 11G	G06_044N02	'TO->FROM'	'KELLY - MADISONCO	230.00 230KV CKT 1'	200	0.74968	117.7065	'HOSKINS - SHELL CREEK 345KV CKT 1'		
FDNS	9	0 11G	G06_044N02	'TO->FROM'	'KELLY - MADISONCO	230.00 230KV CKT 1'	200	0.76682	125.4529	'NELIGH - PETERSBURG 115KV CKT 1'		

SOLUTION GROUP	SCENARIK	SEASON	SOURCE	DIRECTION	MONITORED ELEMENT	COMMON NAME	RATEB	TDF	TC%	LOAD	CONTINGENCY	NAME
FDNS	9	0 11G	G06_044N02	TO->FROM'	'KELLY - MADISONCO	230.00 230KV CKT 1'	200	0.72635	119.7088	'SHELL CREEK 345/230KV TRANSFORMER CKT 1'		
FDNS	9	0 11G	G06_044N02	TO->FROM'	'KELLY - MADISONCO	230.00 230KV CKT 1'	200	0.76746	125.0806	'ATCHSNT3 345.00 - BOONEVILLE 345KV CKT 1'		
FDNS	9	0 11G	G06_044N02	TO->FROM'	'KELLY - MADISONCO	230.00 230KV CKT 1'	200	0.76852	120.8917	'RAUN - SIOUX CITY 345KV CKT 1'		
FDNS	9	0 11G	G06_044N02	TO->FROM'	'KELLY - MADISONCO	230.00 230KV CKT 1'	200	0.7681	123.2956	'NUNDRWD - WAYSIDE 230KV CKT 1'		
FDNS	9	0 11G	G06_044N02	TO->FROM'	'KELLY - MADISONCO	230.00 230KV CKT 1'	200	0.76784	123.7347	'STEGALL - WAYSIDE 230KV CKT 1'		
FDNS	9	0 11G	G06_044N02	TO->FROM'	'KELLY - MADISONCO	230.00 230KV CKT 1'	200	0.76878	129.2914	'UTICA JCT - VFODNES 230KV CKT 1'		
FDNS	9	0 11G	G06_044N02	TO->FROM'	'KELLY - MADISONCO	230.00 230KV CKT 1'	200	0.77655	135.694	'FT RANDAL - UTICA JCT 230KV CKT 1'		
FDNS	9	0 11G	G06_044N02	TO->FROM'	'KELLY - MADISONCO	230.00 230KV CKT 1'	200	0.77407	133.218	'FT RANDAL - SIOUX CITY 230KV CKT 1'		
FDNS	9	0 11G	G06_044N02	TO->FROM'	'KELLY - MADISONCO	230.00 230KV CKT 1'	200	0.76785	124.0883	'GAVINS POINT - YANKON JCT 115KV CKT 1'		
FDNS	9	0 11G	G06_044N02	TO->FROM'	'KELLY - MADISONCO	230.00 230KV CKT 1'	200	0.76954	129.3441	'RASMUSN - UTICA JCT 230KV CKT 1'		
FDNS	9	0 11G	G06_044N02	TO->FROM'	'KELLY - MADISONCO	230.00 230KV CKT 1'	200	0.76954	128.7668	'RASMUSN - SIOUX CITY 230KV CKT 1'		
FDNS	9	0 11G	G06_044N02	TO->FROM'	'KELLY - MADISONCO	230.00 230KV CKT 1'	200	0.98857	160.2117	'FT RANDAL - MADISONCO 230.00 230KV CKT 1'		
FDNS	9	0 11G	G06_044N02	TO->FROM'	'KELLY - MADISONCO	230.00 230KV CKT 1'	200	0.76725	125.7	'G07-11N9 115.00 115/34.5KV TRANSFORMER CKT 1'		
FDNS	9	0 11G	G06_044N02	TO->FROM'	'KELLY - MADISONCO	230.00 230KV CKT 1'	200	0.76725	125.5	'BLOOMFIELD 115/34.5KV TRANSFORMER CKT 1'		
FDNS	9	0 11G	G06_044N02	TO->FROM'	'KELLY - MADISONCO	230.00 230KV CKT 1'	200	0.76727	125.2237	'BLOOMFIELD - GAVINS POINT 115KV CKT 1'		
FDNS	9	0 11G	G06_044N02	TO->FROM'	'KELLY - MADISONCO	230.00 230KV CKT 1'	200	0.76013	125.0901	'KELLY (KLYT1)REG 230/115/13.2KV TRANSFORMER CKT 1'		
FDNS	9	0 11G	G06_044N02	TO->FROM'	'KELLY - MADISONCO	230.00 230KV CKT 1'	200	0.76746	125.4561	'ATCHSNT3 345.00 - COOPER 345KV CKT 1'		
FDNS	9	0 11G	G06_044N02	TO->FROM'	'KELLY - MADISONCO	230.00 230KV CKT 1'	200	0.76725	125.7	'GERALD GENTLEMAN STATION 230/23.0KV TRANSFORMER CK		
FDNS	9	0 11G	G06_044N02	TO->FROM'	'KELLY - MADISONCO	230.00 230KV CKT 1'	200	0.7674	128.8223	'KEYSTONE - SIDNEY 345KV CKT 1'		
FDNS	9	0 11G	G06_044N02	TO->FROM'	'KELLY - MADISONCO	230.00 230KV CKT 1'	200	0.76943	125.0344	'RAUN - SUB 3451 FT CAL 345KV CKT 1'		
FDNS	9	0 11G	G06_044N02	TO->FROM'	'KELLY - MADISONCO	230.00 230KV CKT 1'	200	0.76962	125.6156	'FT THOMPSON - GRAND ISLAND 345KV CKT 1'		
FDNS	9	0 11G	G06_044N02	TO->FROM'	'KELLY - MADISONCO	230.00 230KV CKT 1'	200	0.76725	132.1	'COUNCIL BLUFFS 345/24.0KV TRANSFORMER CKT 1'		
FDNS	9	0 11G	G06_044N02	TO->FROM'	'KELLY - MADISONCO	230.00 230KV CKT 1'	200	0.76725	132.6	'COUNCIL BLUFFS 345/26.0KV TRANSFORMER CKT 1'		
FDNS	9	0 11G	G06_044N02	TO->FROM'	'KELLY - MADISONCO	230.00 230KV CKT 1'	200	0.7667	125.1144	'LAKEFIELD 3 - RAUN 345KV CKT 1'		
FDNS	9	0 11G	G06_044N02	TO->FROM'	'KELLY - MADISONCO	230.00 230KV CKT 1'	200	0.76725	123.7495	'FT RANDAL 230/13.8KV TRANSFORMER CKT 1'		
FDNS	9	0 11G	G06_044N02	TO->FROM'	'KELLY - MADISONCO	230.00 230KV CKT 1'	200	0.76725	125.4987	'FT RANDAL 230/13.8KV TRANSFORMER CKT 1'		
FDNS	9	0 11G	G06_044N02	TO->FROM'	'KELLY - MADISONCO	230.00 230KV CKT 1'	200	0.76725	124.9019	'FT RANDAL 115/13.8KV TRANSFORMER CKT 1'		
FDNS	9	0 11G	G06_044N02	TO->FROM'	'KELLY - MADISONCO	230.00 230KV CKT 1'	200	0.76725	128.7427	'LELAND OLDS 345/20.0KV TRANSFORMER CKT 1'		
FDNS	9	0 11G	G06_044N02	TO->FROM'	'KELLY - MADISONCO	230.00 230KV CKT 1'	200	0.76013	125.0899	'TRF-KELLY'		
FDNS	9	0 11G	G06_044N02	TO->FROM'	'KELLY - MADISONCO	230.00 230KV CKT 1'	200	0.77681	136.063	'DAK02WAPAB2'		
FDNS	9	0 11G	G06_044N02	TO->FROM'	'KELLY - MADISONCO	230.00 230KV CKT 1'	200	0.76725	129.0146	'GEN532751 1-WOLF CREEK GENERATING STATION UNIT 1'		
FDNS	9	0 11G	G06_044N02	TO->FROM'	'KELLY - MADISONCO	230.00 230KV CKT 1'	200	0.76725	129.7298	'GEN640009 1-COOPER NUCLEAR STATION'		
FDNS	9	0 11G	G06_044N02	TO->FROM'	'KELLY - MADISONCO	230.00 230KV CKT 1'	200	0.76725	129.3146	'GEN640028 1-COLUMCOGENERATION'		
FDNS	9	0 11G	G06_044N02	TO->FROM'	'KELLY - MADISONCO	230.00 230KV CKT 1'	200	0.76725	129.199	'GEN645011 1-NEBRASKA CITY 1'		
FDNS	9	0 11G	G06_044N02	TO->FROM'	'KELLY - MADISONCO	230.00 230KV CKT 1'	200	0.76725	129.5189	'GEN645012 2-NEBRASKA CITY 2'		
FDNS	9	2 11G	G06_044N02	TO->FROM'	'KELLY - MADISONCO	230.00 230KV CKT 1'	200	0.76947	95.6	'MADISONCO 230.00 (MADISONCO T1) 230/115/13.8KV TRANSF		
FDNS	9	2 11G	G06_044N02	TO->FROM'	'KELLY - MADISONCO	230.00 230KV CKT 1'	200	0.76947	95.6	'MADISONCO 230.00 (MADISONCO T1) 230/115/13.8KV TRANSF		
FDNS	00G06_04	0 11SP	G06_044N02	TO->FROM'	'KELLY - MADISONCO	230.00 230KV CKT 1'	200	0.77472	100.3796	'ONEILL - SPENCER 115KV CKT 1'		
FDNS	00G06_04	0 11SP	G06_044N02	TO->FROM'	'KELLY - MADISONCO	230.00 230KV CKT 1'	200	0.783	109.2322	'FT RANDAL - UTICA JCT 230KV CKT 1'		
FDNS	00G06_04	0 11SP	G06_044N02	TO->FROM'	'KELLY - MADISONCO	230.00 230KV CKT 1'	200	0.78059	104.203	'FT RANDAL - SIOUX CITY 230KV CKT 1'		
FDNS	00G06_04	0 11SP	G06_044N02	TO->FROM'	'KELLY - MADISONCO	230.00 230KV CKT 1'	200	0.76442	101.6441	'HOSKINS - RAUN 345KV CKT 1'		
FDNS	00G06_04	0 11SP	G06_044N02	TO->FROM'	'KELLY - MADISONCO	230.00 230KV CKT 1'	200	0.77472	100.6527	'FT RANDAL - SPENCER 115KV CKT 1'		
FDNS	00G06_04	0 11SP	G06_044N02	TO->FROM'	'KELLY - MADISONCO	230.00 230KV CKT 1'	200	0.77607	105.8092	'FT THOMPSON - GRAND ISLAND 345KV CKT 1'		
FDNS	00G06_04	0 11SP	G06_044N02	TO->FROM'	'KELLY - MADISONCO	230.00 230KV CKT 1'	200	0.77366	100.1	'COUNCIL BLUFFS 345/24.0KV TRANSFORMER CKT 1'		
FDNS	00G06_04	0 11SP	G06_044N02	TO->FROM'	'KELLY - MADISONCO	230.00 230KV CKT 1'	200	0.77366	100.6	'COUNCIL BLUFFS 345/26.0KV TRANSFORMER CKT 1'		
FDNS	00G06_04	0 11SP	G06_044N02	TO->FROM'	'KELLY - MADISONCO	230.00 230KV CKT 1'	200	0.77472	100.6981	'LN-WAPA6'		
FDNS	00G06_04	0 11SP	G06_044N02	TO->FROM'	'KELLY - MADISONCO	230.00 230KV CKT 1'	200	0.7635	100	'TRF-HOSKINS'		
FDNS	00G06_04	0 11SP	G06_044N02	TO->FROM'	'KELLY - MADISONCO	230.00 230KV CKT 1'	200	0.78329	109.2616	'DAK02WAPAB2'		
FDNS	00G06_04	0 11SP	G06_044N02	TO->FROM'	'KELLY - MADISONCO	230.00 230KV CKT 1'	200	0.77472	100.6981	'NEB001NPPB2'		
FDNS	00G06_04	0 11SP	G06_044N02	TO->FROM'	'KELLY - MADISONCO	230.00 230KV CKT 1'	200	0.77366	100.4476	'GEN532751 1-WOLF CREEK GENERATING STATION UNIT 1'		
FDNS	00G06_04	0 16SP	G06_044N02	TO->FROM'	'KELLY - MADISONCO	230.00 230KV CKT 1'	200	0.75657	100.9734	'COLUMEAST - NW68TH & HOLDREGE 345KV CKT 1'		
FDNS	00G06_04	0 16SP	G06_044N02	TO->FROM'	'KELLY - MADISONCO	230.00 230KV CKT 1'	200	0.74888	100.3569	'COLUMWEST - GRAND ISLAND 230KV CKT 1'		
FDNS	00G06_04	0 16SP	G06_044N02	TO->FROM'	'KELLY - MADISONCO	230.00 230KV CKT 1'	200	0.77345	103.4061	'ONEILL - SPENCER 115KV CKT 1'		
FDNS	00G06_04	0 16SP	G06_044N02	TO->FROM'	'KELLY - MADISONCO	230.00 230KV CKT 1'	200	0.78165	111.4776	'FT RANDAL - UTICA JCT 230KV CKT 1'		
FDNS	00G06_04	0 16SP	G06_044N02	TO->FROM'	'KELLY - MADISONCO	230.00 230KV CKT 1'	200	0.77918	106.1484	'FT RANDAL - SIOUX CITY 230KV CKT 1'		
FDNS	00G06_04	0 16SP	G06_044N02	TO->FROM'	'KELLY - MADISONCO	230.00 230KV CKT 1'	200	0.76294	104.4394	'HOSKINS - RAUN 345KV CKT 1'		
FDNS	00G06_04	0 16SP	G06_044N02	TO->FROM'	'KELLY - MADISONCO	230.00 230KV CKT 1'	200	0.77345	103.6787	'FT RANDAL - SPENCER 115KV CKT 1'		
FDNS	00G06_04	0 16SP	G06_044N02	TO->FROM'	'KELLY - MADISONCO	230.00 230KV CKT 1'	200	0.77438	108.6529	'FT THOMPSON - GRAND ISLAND 345KV CKT 1'		
FDNS	00G06_04	0 16SP	G06_044N02	TO->FROM'	'KELLY - MADISONCO	230.00 230KV CKT 1'	200	0.77242	101.9	'COUNCIL BLUFFS 345/24.0KV TRANSFORMER CKT 1'		
FDNS	00G06_04	0 16SP	G06_044N02	TO->FROM'	'KELLY - MADISONCO	230.00 230KV CKT 1'	200	0.77242	102.3	'COUNCIL BLUFFS 345/26.0KV TRANSFORMER CKT 1'		
FDNS	00G06_04	0 16SP	G06_044N02	TO->FROM'	'KELLY - MADISONCO	230.00 230KV CKT 1'	200	0.77345	103.7222	'LN-WAPA6'		
FDNS	00G06_04	0 16SP	G06_044N02	TO->FROM'	'KELLY - MADISONCO	230.00 230KV CKT 1'	200	0.76207	102.8357	'TRF-HOSKINS'		
FDNS	00G06_04	0 16SP	G06_044N02	TO->FROM'	'KELLY - MADISONCO	230.00 230KV CKT 1'	200	0.78196	111.4328	'DAK02WAPAB2'		
FDNS	00G06_04	0 16SP	G06_044N02	TO->FROM'	'KELLY - MADISONCO	230.00 230KV CKT 1'	200	0.77345	103.7222	'NEB001NPPB2'		
FDNS	00G06_04	0 16SP	G06_044N02	TO->FROM'	'KELLY - MADISONCO	230.00 230KV CKT 1'	200	0.77242	100.049	'GEN336821 1-GRAND GULF UNIT'		
FDNS	00G06_04	0 16SP	G06_044N02	TO->FROM'	'KELLY - MADISONCO	230.00 230KV CKT 1'	200	0.77242	100	'GEN337911 1-ARKANSAS NUCLEAR ONE UNIT #2'		
FDNS	00G06_04	0 16SP	G06_044N02	TO->FROM'	'KELLY - MADISONCO	230.00 230KV CKT 1'	200	0.77242	100.7716	'GEN532651 1-JEFFREY ENERGY CENTER UNIT 1'		

SOLUTION GROUP	SCENARIO	SEASON	SOURCE	DIRECTION	MONITORED ELEMENT	COMMON NAME	RATEB	TDF	TC%	LOAD	CONTINGENCY	NAME
FDNS	00G06_04	0	16SP	G06_044N02	'TO->FROM'	'KELLY - MADISONCO 230.00 230KV CKT 1'	200	0.77242	100.7426	'GEN532652 1-JEFFREY ENERGY CENTER UNIT 2'		
FDNS	00G06_04	0	16SP	G06_044N02	'TO->FROM'	'KELLY - MADISONCO 230.00 230KV CKT 1'	200	0.77242	102.7729	'GEN532751 1-WOLF CREEK GENERATING STATION UNIT 1'		
FDNS	00G06_04	0	16SP	G06_044N02	'TO->FROM'	'KELLY - MADISONCO 230.00 230KV CKT 1'	200	0.77242	100.0713	'GEN542951 5-HAWTHORN UNIT #5'		
FDNS	00G06_04	0	16SP	G06_044N02	'TO->FROM'	'KELLY - MADISONCO 230.00 230KV CKT 1'	200	0.77242	100.7477	'GEN542955 1-LACYGNE UNIT #1'		
FDNS	00G06_04	0	16SP	G06_044N02	'TO->FROM'	'KELLY - MADISONCO 230.00 230KV CKT 1'	200	0.77242	100.3792	'GEN542956 2-LACYGNE UNIT #2'		
FDNS	00G06_04	0	16SP	G06_044N02	'TO->FROM'	'KELLY - MADISONCO 230.00 230KV CKT 1'	200	0.77242	101.0415	'GEN542957 1-IATAN UNIT #1'		
FDNS	00G06_04	0	16SP	G06_044N02	'TO->FROM'	'KELLY - MADISONCO 230.00 230KV CKT 1'	200	0.77242	101.7581	'GEN542962 2-IATAN UNIT #2'		
FDNS	00G06_04	0	16SP	G06_044N02	'TO->FROM'	'KELLY - MADISONCO 230.00 230KV CKT 1'	200	0.77242	102.9103	'GEN640009 1-COOPER NUCLEAR STATION'		
FDNS	00G06_04	0	16SP	G06_044N02	'TO->FROM'	'KELLY - MADISONCO 230.00 230KV CKT 1'	200	0.77242	101.308	'GEN640010 1-GERALD GENTLEMAN STATION UNIT 1'		
FDNS	00G06_04	0	16SP	G06_044N02	'TO->FROM'	'KELLY - MADISONCO 230.00 230KV CKT 1'	200	0.77242	100.7549	'GEN640011 2-GERALD GENTLEMAN STATION UNIT 2'		
FDNS	00G06_04	0	16SP	G06_044N02	'TO->FROM'	'KELLY - MADISONCO 230.00 230KV CKT 1'	200	0.77242	100.0904	'GEN645001 1-FORT CALHOUN 1'		
FDNS	00G06_04	0	16SP	G06_044N02	'TO->FROM'	'KELLY - MADISONCO 230.00 230KV CKT 1'	200	0.77242	101.8518	'GEN645011 1-NEBRASKA CITY 1'		
FDNS	00G06_04	0	16SP	G06_044N02	'TO->FROM'	'KELLY - MADISONCO 230.00 230KV CKT 1'	200	0.77242	102.1072	'GEN645012 2-NEBRASKA CITY 2'		
FDNS	00G06_04	0	11SP	G06_044N02	'TO->FROM'	'KELLY - MADISONCO 230.00 230KV CKT 1'	200	0.77472	100.3796	'ONEILL - SPENCER 115KV CKT 1'		
FDNS	00G06_04	0	11SP	G06_044N02	'TO->FROM'	'KELLY - MADISONCO 230.00 230KV CKT 1'	200	0.783	109.2322	'FT RANDAL - UTICA JCT 230KV CKT 1'		
FDNS	00G06_04	0	11SP	G06_044N02	'TO->FROM'	'KELLY - MADISONCO 230.00 230KV CKT 1'	200	0.78059	104.203	'FT RANDAL - SIOUX CITY 230KV CKT 1'		
FDNS	00G06_04	0	11SP	G06_044N02	'TO->FROM'	'KELLY - MADISONCO 230.00 230KV CKT 1'	200	0.76442	101.6441	'HOSKINS - RAUN 345KV CKT 1'		
FDNS	00G06_04	0	11SP	G06_044N02	'TO->FROM'	'KELLY - MADISONCO 230.00 230KV CKT 1'	200	0.77472	100.6527	'FT RANDAL - SPENCER 115KV CKT 1'		
FDNS	00G06_04	0	11SP	G06_044N02	'TO->FROM'	'KELLY - MADISONCO 230.00 230KV CKT 1'	200	0.77607	105.8092	'FT THOMPSON - GRAND ISLAND 345KV CKT 1'		
FDNS	00G06_04	0	11SP	G06_044N02	'TO->FROM'	'KELLY - MADISONCO 230.00 230KV CKT 1'	200	0.77366	100.1	'COUNCIL BLUFFS 345/24.0KV TRANSFORMER CKT 1'		
FDNS	00G06_04	0	11SP	G06_044N02	'TO->FROM'	'KELLY - MADISONCO 230.00 230KV CKT 1'	200	0.77366	100.6	'COUNCIL BLUFFS 345/26.0KV TRANSFORMER CKT 1'		
FDNS	00G06_04	0	11SP	G06_044N02	'TO->FROM'	'KELLY - MADISONCO 230.00 230KV CKT 1'	200	0.77472	100.6981	'LN-WAPA6'		
FDNS	00G06_04	0	11SP	G06_044N02	'TO->FROM'	'KELLY - MADISONCO 230.00 230KV CKT 1'	200	0.7635	100	'TRF-HOSKINS'		
FDNS	00G06_04	0	11SP	G06_044N02	'TO->FROM'	'KELLY - MADISONCO 230.00 230KV CKT 1'	200	0.78329	109.2616	'DAK02WAPAB2'		
FDNS	00G06_04	0	11SP	G06_044N02	'TO->FROM'	'KELLY - MADISONCO 230.00 230KV CKT 1'	200	0.77472	100.6981	'NEB001NPPB2'		
FDNS	00G06_04	0	11SP	G06_044N02	'TO->FROM'	'KELLY - MADISONCO 230.00 230KV CKT 1'	200	0.77366	100.4476	'GEN532751 1-WOLF CREEK GENERATING STATION UNIT 1'		
FDNS	00G06_04	0	16SP	G06_044N02	'TO->FROM'	'KELLY - MADISONCO 230.00 230KV CKT 1'	200	0.75657	100.9734	'COLUMEAST - NW68TH & HOLDREGE 345KV CKT 1'		
FDNS	00G06_04	0	16SP	G06_044N02	'TO->FROM'	'KELLY - MADISONCO 230.00 230KV CKT 1'	200	0.74888	100.3569	'COLUMWEST - GRAND ISLAND 230KV CKT 1'		
FDNS	00G06_04	0	16SP	G06_044N02	'TO->FROM'	'KELLY - MADISONCO 230.00 230KV CKT 1'	200	0.77345	103.4061	'ONEILL - SPENCER 115KV CKT 1'		
FDNS	00G06_04	0	16SP	G06_044N02	'TO->FROM'	'KELLY - MADISONCO 230.00 230KV CKT 1'	200	0.78165	111.4776	'FT RANDAL - UTICA JCT 230KV CKT 1'		
FDNS	00G06_04	0	16SP	G06_044N02	'TO->FROM'	'KELLY - MADISONCO 230.00 230KV CKT 1'	200	0.77918	106.1484	'FT RANDAL - SIOUX CITY 230KV CKT 1'		
FDNS	00G06_04	0	16SP	G06_044N02	'TO->FROM'	'KELLY - MADISONCO 230.00 230KV CKT 1'	200	0.76294	104.4394	'HOSKINS - RAUN 345KV CKT 1'		
FDNS	00G06_04	0	16SP	G06_044N02	'TO->FROM'	'KELLY - MADISONCO 230.00 230KV CKT 1'	200	0.77345	103.6787	'FT RANDAL - SPENCER 115KV CKT 1'		
FDNS	00G06_04	0	16SP	G06_044N02	'TO->FROM'	'KELLY - MADISONCO 230.00 230KV CKT 1'	200	0.77438	108.6529	'FT THOMPSON - GRAND ISLAND 345KV CKT 1'		
FDNS	00G06_04	0	16SP	G06_044N02	'TO->FROM'	'KELLY - MADISONCO 230.00 230KV CKT 1'	200	0.77242	101.9	'COUNCIL BLUFFS 345/24.0KV TRANSFORMER CKT 1'		
FDNS	00G06_04	0	16SP	G06_044N02	'TO->FROM'	'KELLY - MADISONCO 230.00 230KV CKT 1'	200	0.77242	102.3	'COUNCIL BLUFFS 345/26.0KV TRANSFORMER CKT 1'		
FDNS	00G06_04	0	16SP	G06_044N02	'TO->FROM'	'KELLY - MADISONCO 230.00 230KV CKT 1'	200	0.77345	103.7222	'LN-WAPA6'		
FDNS	00G06_04	0	16SP	G06_044N02	'TO->FROM'	'KELLY - MADISONCO 230.00 230KV CKT 1'	200	0.76207	102.8357	'TRF-HOSKINS'		
FDNS	00G06_04	0	16SP	G06_044N02	'TO->FROM'	'KELLY - MADISONCO 230.00 230KV CKT 1'	200	0.78196	111.4328	'DAK02WAPAB2'		
FDNS	00G06_04	0	16SP	G06_044N02	'TO->FROM'	'KELLY - MADISONCO 230.00 230KV CKT 1'	200	0.77345	103.7222	'NEB001NPPB2'		
FDNS	00G06_04	0	16SP	G06_044N02	'TO->FROM'	'KELLY - MADISONCO 230.00 230KV CKT 1'	200	0.77242	100.049	'GEN336821 1-GRAND GULF UNIT'		
FDNS	00G06_04	0	16SP	G06_044N02	'TO->FROM'	'KELLY - MADISONCO 230.00 230KV CKT 1'	200	0.77242	100	'GEN337911 1-ARKANSAS NUCLEAR ONE UNIT #2'		
FDNS	00G06_04	0	16SP	G06_044N02	'TO->FROM'	'KELLY - MADISONCO 230.00 230KV CKT 1'	200	0.77242	100.7716	'GEN532651 1-JEFFREY ENERGY CENTER UNIT 1'		
FDNS	00G06_04	0	16SP	G06_044N02	'TO->FROM'	'KELLY - MADISONCO 230.00 230KV CKT 1'	200	0.77242	100.7426	'GEN532652 1-JEFFREY ENERGY CENTER UNIT 2'		
FDNS	00G06_04	0	16SP	G06_044N02	'TO->FROM'	'KELLY - MADISONCO 230.00 230KV CKT 1'	200	0.77242	102.7729	'GEN532751 1-WOLF CREEK GENERATING STATION UNIT 1'		
FDNS	00G06_04	0	16SP	G06_044N02	'TO->FROM'	'KELLY - MADISONCO 230.00 230KV CKT 1'	200	0.77242	100.0713	'GEN542951 5-HAWTHORN UNIT #5'		
FDNS	00G06_04	0	16SP	G06_044N02	'TO->FROM'	'KELLY - MADISONCO 230.00 230KV CKT 1'	200	0.77242	100.7477	'GEN542955 1-LACYGNE UNIT #1'		
FDNS	00G06_04	0	16SP	G06_044N02	'TO->FROM'	'KELLY - MADISONCO 230.00 230KV CKT 1'	200	0.77242	100.3792	'GEN542956 2-LACYGNE UNIT #2'		
FDNS	00G06_04	0	16SP	G06_044N02	'TO->FROM'	'KELLY - MADISONCO 230.00 230KV CKT 1'	200	0.77242	101.0415	'GEN542957 1-IATAN UNIT #1'		
FDNS	00G06_04	0	16SP	G06_044N02	'TO->FROM'	'KELLY - MADISONCO 230.00 230KV CKT 1'	200	0.77242	101.7581	'GEN542962 2-IATAN UNIT #2'		
FDNS	00G06_04	0	16SP	G06_044N02	'TO->FROM'	'KELLY - MADISONCO 230.00 230KV CKT 1'	200	0.77242	102.9103	'GEN640009 1-COOPER NUCLEAR STATION'		
FDNS	00G06_04	0	16SP	G06_044N02	'TO->FROM'	'KELLY - MADISONCO 230.00 230KV CKT 1'	200	0.77242	101.308	'GEN640010 1-GERALD GENTLEMAN STATION UNIT 1'		
FDNS	00G06_04	0	16SP	G06_044N02	'TO->FROM'	'KELLY - MADISONCO 230.00 230KV CKT 1'	200	0.77242	100.7549	'GEN640011 2-GERALD GENTLEMAN STATION UNIT 2'		
FDNS	00G06_04	0	16SP	G06_044N02	'TO->FROM'	'KELLY - MADISONCO 230.00 230KV CKT 1'	200	0.77242	100.0904	'GEN645001 1-FORT CALHOUN 1'		
FDNS	00G06_04	0	16SP	G06_044N02	'TO->FROM'	'KELLY - MADISONCO 230.00 230KV CKT 1'	200	0.77242	101.8518	'GEN645011 1-NEBRASKA CITY 1'		
FDNS	00G06_04	0	16SP	G06_044N02	'TO->FROM'	'KELLY - MADISONCO 230.00 230KV CKT 1'	200	0.77242	102.1072	'GEN645012 2-NEBRASKA CITY 2'		
FNSL-Itera 02ALL		0	11G	G06_044N02	Non Converged		1052	0.17587	77.23053	'FINNEY SWITCHING STATION - STEVENSCO 345.00 345KV CKT'		
FNSL-Itera 02ALL		0	11G	G06_044N02	Non Converged		0	0.13769	9999	'DBL-G0847-WO'		
FNSL-Itera 02ALL		0	11G	G06_044N02	Non Converged		1052	0.12092	76.82405	'FINNEY SWITCHING STATION - STEVENSCO 345.00 345KV CKT'		
FNSL-Itera 02ALL		0	11G	G06_044N02	Non Converged		441	0.10556	57.58744	'STATLINE INTERCHANGE - STLN-DEMARC6230.00 230KV CKT'		
FNSL-Itera 02ALL		0	11G	G06_044N02	Non Converged		0	0.08065	9999	'ATC_B2_8E2_G'		
FNSL-Itera 02ALL		0	11G	G06_044N02	Non Converged		0	0.0783	9999	'050_1'		
FNSL-Itera 02ALL		0	11G	G06_044N02	Non Converged		0	0.07559	9999	'ATC_B2_8E2'		
FNSL-Itera 02ALL		0	11G	G06_044N02	Non Converged		0	0.07534	9999	'ATC_B2_8E2'		
FNSL-Itera 02ALL		0	11G	G06_044N02	Non Converged		0	0.07377	9999	'050_2'		
FNSL-Itera 02ALL		0	11G	G06_044N02	Non Converged		351	0.06554	81.98898	'GRAPEVINE INTERCHANGE - NICHOLS STATION 230KV CKT 1'		
FNSL-Itera 02ALL		0	11G	G06_044N02	Non Converged		351	0.05447	82.03278	'GRAPEVINE INTERCHANGE - NICHOLS STATION 230KV CKT 1'		

SOLUTION GROUP	SCENARI	SEASON	SOURCE	DIRECTION	MONITORED ELEMENT	COMMON NAME	RATEB	TDF	TC%	LOAD	CONTINGENCY	NAME
FNSL-Itera 02ALL		0 11G	G06_044N02		Non Converged		0	0.05243	9999	'SPP-SWPS-03'		
FNSL-Itera 02ALL		0 11G	G06_044N02		Non Converged		0	0.04963	9999	'050 2'		
FNSL-Itera 02ALL		0 11G	G06_044N02		Non Converged		0	0.04149	9999	'DBL-G0847-WO'		
FNSL-Itera 02ALL		0 11G	G06_044N02		Non Converged		0	0.03147	9999	'ATC_B2_8E2_G'		
FNSL-Itera 02ALL		0 11G	G06_044N02		Non Converged		0	0.02996	9999	'050 1'		
FNSL-Itera 02ALL		0 11G	G06_044N02		Non Converged		0	0.02784	9999	'050 2'		
FNSL-Itera 02ALL		0 11G	G06_044N02		Non Converged		0	0.02349	9999	'ATC_B2_8E2_G'		
FNSL-Itera 02ALL		0 11G	G06_044N02		Non Converged		0	0.02259	9999	'050 1'		
FNSL-Itera 02ALL		0 11G	G06_044N02		Non Converged		441	0.022	57.61415	'STATELINE INTERCHANGE - STLN-DEMARC6230.00 230KV CKT		
FNSL-Itera 00G06_04		0 11WP	G06_044N02		Non Converged		0	0.08104	9999	'ATC_B2_8E2_G'		
FNSL-Itera 00G06_04		0 11WP	G06_044N02		Non Converged		1793	0.03931	20.1115	'GEN300015 1-1SGPDEL	18.000'	
FNSL-Itera 00G06_04		0 16SP	G06_044N02		Non Converged		0	0.03451	9999	'IWA001WAPAB2'		
FNSL-Itera 00G06_04		0 16SP	G06_044N02		Non Converged		0	0.03451	9999	'ALTW-B111-SW'		
FNSL-Itera 0		0 16SP	G06_044N02		Non Converged		0	0.03458	9999	'IWA001WAPAB2'		
FNSL-Itera 0		0 16SP	G06_044N02		Non Converged		0	0.03458	9999	'ALTW-B111-SW'		
FNSL-Itera 0		0 11WP	G06_044N02		Non Converged		0	0.0813	9999	'ATC_B2_8E2_G'		
FNSL-Itera 0		0 11WP	G06_044N02		Non Converged		1793	0.03943	19.91273	'GEN300015 1-1SGPDEL	18.000'	
FNSL-Itera 1		0 11G	G06_044N02		Non Converged		0	0.0788	9999	'050 1'		
FNSL-Itera 1		0 11G	G06_044N02		Non Converged		0	0.07434	9999	'050 2'		
FNSL-Itera 1		0 11G	G06_044N02		Non Converged		0	0.07605	9999	'ATC_B2_8E2'		
FNSL-Itera 1		0 11G	G06_044N02		Non Converged		0	0.08123	9999	'ATC_B2_8E2_G'		
FNSL-Itera 1		2 11G	G06_044N02		Non Converged		0	0.07882	9999	'050 1'		
FNSL-Itera 1		2 11G	G06_044N02		Non Converged		0	0.07437	9999	'050 2'		
FNSL-Itera 1		2 11G	G06_044N02		Non Converged		0	0.07607	9999	'ATC_B2_8E2'		
FNSL-Itera 1		2 11G	G06_044N02		Non Converged		0	0.08125	9999	'ATC_B2_8E2_G'		
FNSL-Itera 02ALL		0 11G	G06_044N02		Non Converged		0	0.07801	9999	'050 1'		
FNSL-Itera 02ALL		0 11G	G06_044N02		Non Converged		0	0.0736	9999	'050 2'		
FNSL-Itera 02ALL		0 11G	G06_044N02		Non Converged		0	0.07529	9999	'ATC_B2_8E2'		
FNSL-Itera 02ALL		0 11G	G06_044N02		Non Converged		0	0.08042	9999	'ATC_B2_8E2_G'		
FNSL-Itera 02ALL		2 11G	G06_044N02		Non Converged		0	0.07807	9999	'050 1'		
FNSL-Itera 02ALL		2 11G	G06_044N02		Non Converged		0	0.07365	9999	'050 2'		
FNSL-Itera 02ALL		2 11G	G06_044N02		Non Converged		0	0.07534	9999	'ATC_B2_8E2'		
FNSL-Itera 02ALL		2 11G	G06_044N02		Non Converged		0	0.08048	9999	'ATC_B2_8E2_G'		
FNSL-Itera 02ALL		3 11G	G06_044N02		Non Converged		0	0.07819	9999	'050 1'		
FNSL-Itera 02ALL		3 11G	G06_044N02		Non Converged		0	0.07377	9999	'050 2'		
FNSL-Itera 02ALL		3 11G	G06_044N02		Non Converged		0	0.07546	9999	'ATC_B2_8E2'		
FNSL-Itera 02ALL		3 11G	G06_044N02		Non Converged		0	0.08061	9999	'ATC_B2_8E2_G'		
FNSL-Itera 02G08110		0 11G	G06_044N02		Non Converged		0	0.07821	9999	'050 1'		
FNSL-Itera 02G08110		0 11G	G06_044N02		Non Converged		0	0.07379	9999	'050 2'		
FNSL-Itera 02G08110		0 11G	G06_044N02		Non Converged		0	0.07548	9999	'ATC_B2_8E2'		
FNSL-Itera 02G08110		0 11G	G06_044N02		Non Converged		0	0.08062	9999	'ATC_B2_8E2_G'		
FNSL-Itera 02G08110		2 11G	G06_044N02		Non Converged		0	0.07824	9999	'050 1'		
FNSL-Itera 02G08110		2 11G	G06_044N02		Non Converged		0	0.07382	9999	'050 2'		
FNSL-Itera 02G08110		2 11G	G06_044N02		Non Converged		0	0.07551	9999	'ATC_B2_8E2'		
FNSL-Itera 02G08110		2 11G	G06_044N02		Non Converged		0	0.08065	9999	'ATC_B2_8E2_G'		
FNSL-Itera 02G08110		3 11G	G06_044N02		Non Converged		0	0.07832	9999	'050 1'		
FNSL-Itera 02G08110		3 11G	G06_044N02		Non Converged		0	0.07389	9999	'050 2'		
FNSL-Itera 02G08110		3 11G	G06_044N02		Non Converged		0	0.07559	9999	'ATC_B2_8E2'		
FNSL-Itera 02G08110		3 11G	G06_044N02		Non Converged		0	0.08073	9999	'ATC_B2_8E2_G'		
FNSL-Itera 02G0847		0 11G	G06_044N02		Non Converged		0	0.07818	9999	'050 1'		
FNSL-Itera 02G0847		0 11G	G06_044N02		Non Converged		0	0.07376	9999	'050 2'		
FNSL-Itera 02G0847		0 11G	G06_044N02		Non Converged		0	0.07545	9999	'ATC_B2_8E2'		
FNSL-Itera 02G0847		0 11G	G06_044N02		Non Converged		0	0.08059	9999	'ATC_B2_8E2_G'		
FNSL-Itera 02G0847		2 11G	G06_044N02		Non Converged		0	0.07821	9999	'050 1'		
FNSL-Itera 02G0847		2 11G	G06_044N02		Non Converged		0	0.07379	9999	'050 2'		
FNSL-Itera 02G0847		2 11G	G06_044N02		Non Converged		0	0.07548	9999	'ATC_B2_8E2'		
FNSL-Itera 02G0847		2 11G	G06_044N02		Non Converged		0	0.08062	9999	'ATC_B2_8E2_G'		
FNSL-Itera 02G0847		3 11G	G06_044N02		Non Converged		0	0.0783	9999	'050 1'		
FNSL-Itera 02G0847		3 11G	G06_044N02		Non Converged		0	0.07387	9999	'050 2'		
FNSL-Itera 02G0847		3 11G	G06_044N02		Non Converged		0	0.07557	9999	'ATC_B2_8E2'		
FNSL-Itera 02G0847		3 11G	G06_044N02		Non Converged		0	0.08071	9999	'ATC_B2_8E2_G'		
FNSL-Itera 02G1007		0 11G	G06_044N02		Non Converged		0	0.0782	9999	'050 1'		
FNSL-Itera 02G1007		0 11G	G06_044N02		Non Converged		0	0.07378	9999	'050 2'		
FNSL-Itera 02G1007		0 11G	G06_044N02		Non Converged		0	0.07547	9999	'ATC_B2_8E2'		
FNSL-Itera 02G1007		0 11G	G06_044N02		Non Converged		0	0.08061	9999	'ATC_B2_8E2_G'		
FNSL-Itera 02G1007		2 11G	G06_044N02		Non Converged		0	0.07823	9999	'050 1'		
FNSL-Itera 02G1007		2 11G	G06_044N02		Non Converged		0	0.07381	9999	'050 2'		

SOLUTION GROUP	SCENARI SEASON	SOURCE	DIRECTION	MONITORED ELEMENT	COMMON NAME	RATEB	TDF	TC%	LOAD	CONTINGENCY	NAME
FNSL-Itera 02G1007	2	11G	G06_044N02		Non Converged	0	0.0755	9999	'ATC_B2_8E2'		
FNSL-Itera 02G1007	2	11G	G06_044N02		Non Converged	0	0.08064	9999	'ATC_B2_8E2_G'		
FNSL-Itera 02G1007	3	11G	G06_044N02		Non Converged	0	0.07831	9999	'050 1'		
FNSL-Itera 02G1007	3	11G	G06_044N02		Non Converged	0	0.07389	9999	'050 2'		
FNSL-Itera 02G1007	3	11G	G06_044N02		Non Converged	0	0.07558	9999	'ATC_B2_8E2'		
FNSL-Itera 02G1007	3	11G	G06_044N02		Non Converged	0	0.08072	9999	'ATC_B2_8E2_G'		
FNSL-Itera 02G1014	0	11G	G06_044N02		Non Converged	0	0.07818	9999	'050 1'		
FNSL-Itera 02G1014	0	11G	G06_044N02		Non Converged	0	0.07377	9999	'050 2'		
FNSL-Itera 02G1014	0	11G	G06_044N02		Non Converged	0	0.07546	9999	'ATC_B2_8E2'		
FNSL-Itera 02G1014	0	11G	G06_044N02		Non Converged	0	0.08059	9999	'ATC_B2_8E2_G'		
FNSL-Itera 02G1014	2	11G	G06_044N02		Non Converged	0	0.07822	9999	'050 1'		
FNSL-Itera 02G1014	2	11G	G06_044N02		Non Converged	0	0.0738	9999	'050 2'		
FNSL-Itera 02G1014	2	11G	G06_044N02		Non Converged	0	0.07549	9999	'ATC_B2_8E2'		
FNSL-Itera 02G1014	2	11G	G06_044N02		Non Converged	0	0.08063	9999	'ATC_B2_8E2_G'		
FNSL-Itera 02G1014	3	11G	G06_044N02		Non Converged	0	0.0783	9999	'050 1'		
FNSL-Itera 02G1014	3	11G	G06_044N02		Non Converged	0	0.07388	9999	'050 2'		
FNSL-Itera 02G1014	3	11G	G06_044N02		Non Converged	0	0.07557	9999	'ATC_B2_8E2'		
FNSL-Itera 02G1014	3	11G	G06_044N02		Non Converged	0	0.08072	9999	'ATC_B2_8E2_G'		
FNSL-Itera	2	0	11G	G06_044N02	Non Converged	0	0.0782	9999	'050 1'		
FNSL-Itera	2	0	11G	G06_044N02	Non Converged	0	0.07378	9999	'050 2'		
FNSL-Itera	2	0	11G	G06_044N02	Non Converged	0	0.07547	9999	'ATC_B2_8E2'		
FNSL-Itera	2	0	11G	G06_044N02	Non Converged	0	0.08061	9999	'ATC_B2_8E2_G'		
FNSL-Itera	2	2	11G	G06_044N02	Non Converged	0	0.07823	9999	'050 1'		
FNSL-Itera	2	2	11G	G06_044N02	Non Converged	0	0.07381	9999	'050 2'		
FNSL-Itera	2	2	11G	G06_044N02	Non Converged	0	0.0755	9999	'ATC_B2_8E2'		
FNSL-Itera	2	2	11G	G06_044N02	Non Converged	0	0.08064	9999	'ATC_B2_8E2_G'		
FNSL-Itera	2	3	11G	G06_044N02	Non Converged	0	0.07831	9999	'050 1'		
FNSL-Itera	2	3	11G	G06_044N02	Non Converged	0	0.07389	9999	'050 2'		
FNSL-Itera	2	3	11G	G06_044N02	Non Converged	0	0.07558	9999	'ATC_B2_8E2'		
FNSL-Itera	2	3	11G	G06_044N02	Non Converged	0	0.08073	9999	'ATC_B2_8E2_G'		
FNSL-Blow 03ALL	0	11G	G06_044N02		Non Converged	0	0.03554	9999	'DBL-SPRVL-CO'		
FNSL-Blow 03ALL	0	11G	G06_044N02		Non Converged	0	0.03554	9999	'DBL-COM-MEDL'		
FNSL-Itera 03ALL	0	11G	G06_044N02		Non Converged	0	0.0772	9999	'050 1'		
FNSL-Itera 03ALL	0	11G	G06_044N02		Non Converged	0	0.07285	9999	'050 2'		
FNSL-Itera 03ALL	0	11G	G06_044N02		Non Converged	0	0.07451	9999	'ATC_B2_8E2'		
FNSL-Itera 03ALL	0	11G	G06_044N02		Non Converged	0	0.07958	9999	'ATC_B2_8E2_G'		
FNSL-Itera	3	0	11G	G06_044N02	Non Converged	0	0.07769	9999	'050 1'		
FNSL-Itera	3	0	11G	G06_044N02	Non Converged	0	0.07331	9999	'050 2'		
FNSL-Itera	3	0	11G	G06_044N02	Non Converged	0	0.07498	9999	'ATC_B2_8E2'		
FNSL-Itera	3	0	11G	G06_044N02	Non Converged	0	0.08008	9999	'ATC_B2_8E2_G'		
FNSL-Itera	3	2	11G	G06_044N02	Non Converged	0	0.0777	9999	'050 1'		
FNSL-Itera	3	2	11G	G06_044N02	Non Converged	0	0.07331	9999	'050 2'		
FNSL-Itera	3	2	11G	G06_044N02	Non Converged	0	0.07498	9999	'ATC_B2_8E2'		
FNSL-Itera	3	2	11G	G06_044N02	Non Converged	0	0.08008	9999	'ATC_B2_8E2_G'		
FNSL-Itera	5	0	11G	G06_044N02	Non Converged	0	0.07869	9999	'050 1'		
FNSL-Itera	5	0	11G	G06_044N02	Non Converged	0	0.07424	9999	'050 2'		
FNSL-Itera	5	0	11G	G06_044N02	Non Converged	0	0.07594	9999	'ATC_B2_8E2'		
FNSL-Itera	5	0	11G	G06_044N02	Non Converged	0	0.08111	9999	'ATC_B2_8E2_G'		
FNSL-Itera	6	0	11G	G06_044N02	Non Converged	0	0.07884	9999	'050 1'		
FNSL-Itera	6	0	11G	G06_044N02	Non Converged	0	0.07439	9999	'050 2'		
FNSL-Itera	6	0	11G	G06_044N02	Non Converged	0	0.07609	9999	'ATC_B2_8E2'		
FNSL-Itera	6	0	11G	G06_044N02	Non Converged	0	0.08128	9999	'ATC_B2_8E2_G'		
FNSL-Itera	7	0	11G	G06_044N02	Non Converged	0	0.07907	9999	'050 1'		
FNSL-Itera	7	0	11G	G06_044N02	Non Converged	0	0.0746	9999	'050 2'		
FNSL-Itera	7	0	11G	G06_044N02	Non Converged	0	0.07631	9999	'ATC_B2_8E2'		
FNSL-Itera	7	0	11G	G06_044N02	Non Converged	0	0.08151	9999	'ATC_B2_8E2_G'		
FNSL-Itera	7	2	11G	G06_044N02	Non Converged	0	0.07908	9999	'050 1'		
FNSL-Itera	7	2	11G	G06_044N02	Non Converged	0	0.07461	9999	'050 2'		
FNSL-Itera	7	2	11G	G06_044N02	Non Converged	0	0.07632	9999	'ATC_B2_8E2'		
FNSL-Itera	7	2	11G	G06_044N02	Non Converged	0	0.08152	9999	'ATC_B2_8E2_G'		
FNSL-Itera	8	0	11G	G06_044N02	Non Converged	0	0.0789	9999	'050 1'		
FNSL-Itera	8	0	11G	G06_044N02	Non Converged	0	0.07445	9999	'050 2'		
FNSL-Itera	8	0	11G	G06_044N02	Non Converged	0	0.07615	9999	'ATC_B2_8E2'		
FNSL-Itera	8	0	11G	G06_044N02	Non Converged	0	0.08133	9999	'ATC_B2_8E2_G'		
FNSL-Itera	9	0	11G	G06_044N02	Non Converged	0	0.07749	9999	'050 1'		
FNSL-Itera	9	0	11G	G06_044N02	Non Converged	0	0.07312	9999	'050 2'		
FNSL-Itera	9	0	11G	G06_044N02	Non Converged	0	0.07479	9999	'ATC_B2_8E2'		

SOLUTION GROUP	SCENARI	SEASON	SOURCE	DIRECTION	MONITORED ELEMENT	COMMON NAME	RATEB	TDF	TC%	LOAD CONTINGENCY	NAME
FNSL-Itera	9	0 11G	G06_044N02		Non Converged		0	0.07988	9999	'ATC_B2_8E2_G'	
FNSL-Itera	9	2 11G	G06_044N02		Non Converged		0	0.07807	9999	'050 1'	
FNSL-Itera	9	2 11G	G06_044N02		Non Converged		0	0.07362	9999	'050 2'	
FNSL-Itera	9	2 11G	G06_044N02		Non Converged		0	0.07535	9999	'ATC_B2_8E2'	
FNSL-Itera	9	2 11G	G06_044N02		Non Converged		0	0.08052	9999	'ATC_B2_8E2_G'	
FNSL-Itera	11	0 11G	G06_044N02		Non Converged		0	0.0784	9999	'050 1'	
FNSL-Itera	11	0 11G	G06_044N02		Non Converged		0	0.07398	9999	'050 2'	
FNSL-Itera	11	0 11G	G06_044N02		Non Converged		0	0.07567	9999	'ATC_B2_8E2'	
FNSL-Itera	11	0 11G	G06_044N02		Non Converged		0	0.08081	9999	'ATC_B2_8E2_G'	
FNSL-Itera	11	2 11G	G06_044N02		Non Converged		0	0.0784	9999	'050 1'	
FNSL-Itera	11	2 11G	G06_044N02		Non Converged		0	0.07398	9999	'050 2'	
FNSL-Itera	11	2 11G	G06_044N02		Non Converged		0	0.07567	9999	'ATC_B2_8E2'	
FNSL-Itera	11	2 11G	G06_044N02		Non Converged		0	0.08081	9999	'ATC_B2_8E2_G'	
FNSL-Itera	13	0 11G	G06_044N02		Non Converged		0	0.07816	9999	'050 1'	
FNSL-Itera	13	0 11G	G06_044N02		Non Converged		0	0.07376	9999	'050 2'	
FNSL-Itera	13	0 11G	G06_044N02		Non Converged		0	0.07543	9999	'ATC_B2_8E2'	
FNSL-Itera	13	0 11G	G06_044N02		Non Converged		0	0.08055	9999	'ATC_B2_8E2_G'	
FNSL-Itera	14	0 11G	G06_044N02		Non Converged		0	0.07896	9999	'050 1'	
FNSL-Itera	14	0 11G	G06_044N02		Non Converged		0	0.0745	9999	'050 2'	
FNSL-Itera	14	0 11G	G06_044N02		Non Converged		0	0.0762	9999	'ATC_B2_8E2'	
FNSL-Itera	14	0 11G	G06_044N02		Non Converged		0	0.08139	9999	'ATC_B2_8E2_G'	
FNSL-Itera	15	0 11G	G06_044N02		Non Converged		0	0.07881	9999	'050 1'	
FNSL-Itera	15	0 11G	G06_044N02		Non Converged		0	0.07436	9999	'050 2'	
FNSL-Itera	15	0 11G	G06_044N02		Non Converged		0	0.07606	9999	'ATC_B2_8E2'	
FNSL-Itera	15	0 11G	G06_044N02		Non Converged		0	0.08124	9999	'ATC_B2_8E2_G'	
FDNS	1	2 11G	G08_022	'FROM->TO'	'DEAF SMITH COUNTY INTERCHANGE - S-RANDLCO		350	0.20897	96.5	'TOLK STATION EAST 230/24.0KV TRANSFORMER CKT 1'	
FDNS	1	2 11G	G08_022	'FROM->TO'	'DEAF SMITH COUNTY INTERCHANGE - S-RANDLCO		350	0.20897	96.5	'TOLK STATION EAST 230/24.0KV TRANSFORMER CKT 1'	
FDNS	2	0 11G	G08_022	'FROM->TO'	'DEAF SMITH COUNTY INTERCHANGE - S-RANDLCO		350	0.21234	116.9	'TOLK STATION EAST 230/24.0KV TRANSFORMER CKT 1'	
FDNS	2	0 11G	G08_022	'TO->FROM'	'FINNEY SWITCHING STATION - STEVENSCO 345.00		1052	0.20521	111.9602	'DBL-HIT-G084'	
FDNS	2	0 11G	G08_022	'FROM->TO'	'DEAF SMITH COUNTY INTERCHANGE - S-RANDLCO		350	0.21234	116.9	'TOLK STATION EAST 230/24.0KV TRANSFORMER CKT 1'	
FDNS	2	0 11G	G08_022	'TO->FROM'	'FINNEY SWITCHING STATION - STEVENSCO 345.00		1052	0.20521	111.9602	'DBL-HIT-G084'	
FDNS	2	2 11G	G08_022	'FROM->TO'	'DEAF SMITH COUNTY INTERCHANGE - S-RANDLCO		350	0.20977	106	'TOLK STATION EAST 230/24.0KV TRANSFORMER CKT 1'	
FDNS	2	2 11G	G08_022	'FROM->TO'	'DEAF SMITH COUNTY INTERCHANGE - S-RANDLCO		350	0.20977	106	'TOLK STATION EAST 230/24.0KV TRANSFORMER CKT 1'	
FDNS	3	2 11G	G08_022	'FROM->TO'	'DEAF SMITH COUNTY INTERCHANGE - S-RANDLCO		350	0.21072	98.5	'TOLK STATION EAST 230/24.0KV TRANSFORMER CKT 1'	
FDNS	3	2 11G	G08_022	'FROM->TO'	'DEAF SMITH COUNTY INTERCHANGE - S-RANDLCO		350	0.21072	98.5	'TOLK STATION EAST 230/24.0KV TRANSFORMER CKT 1'	
FDNS	5	0 11G	G08_022	'FROM->TO'	'DEAF SMITH COUNTY INTERCHANGE - S-RANDLCO		350	0.21473	108.2	'OKLAUN - OKLAUNION 345KV CKT 1'	
FDNS	5	0 11G	G08_022	'FROM->TO'	'DEAF SMITH COUNTY INTERCHANGE - S-RANDLCO		350	0.21473	104.3	'ASGI-10-11 69.000 - TRI COUNTY REC-TEXAS COUNTY INTERC	
FDNS	5	0 11G	G08_022	'FROM->TO'	'DEAF SMITH COUNTY INTERCHANGE - S-RANDLCO		350	0.21473	102.7	'G02-006 115.00 - TEXAS COUNTY INTERCHANGE 115KV CKT	
FDNS	5	0 11G	G08_022	'FROM->TO'	'DEAF SMITH COUNTY INTERCHANGE - S-RANDLCO		350	0.21473	101.8	'G07-46 115.00 - HITCHLAND INTERCHANGE 115KV CKT 1'	
FDNS	5	0 11G	G08_022	'FROM->TO'	'DEAF SMITH COUNTY INTERCHANGE - S-RANDLCO		350	0.21473	103.7	'HUBER GEN - INDUSTRIAL SUB 69KV CKT 1'	
FDNS	5	0 11G	G08_022	'FROM->TO'	'DEAF SMITH COUNTY INTERCHANGE - S-RANDLCO		350	0.21473	103.7	'INDUSTRIAL SUB - SID RICHARDSON (PHILLIPS) GEN 69KV CKT	
FDNS	5	0 11G	G08_022	'FROM->TO'	'DEAF SMITH COUNTY INTERCHANGE - S-RANDLCO		350	0.21473	102.4	'VEGA SUB - WILDORADO 69KV CKT 1'	
FDNS	5	0 11G	G08_022	'FROM->TO'	'DEAF SMITH COUNTY INTERCHANGE - S-RANDLCO		350	0.21473	102.1	'G08-88 69.000 - VEGA SUB 69KV CKT 1'	
FDNS	5	0 11G	G08_022	'FROM->TO'	'DEAF SMITH COUNTY INTERCHANGE - S-RANDLCO		350	0.21473	102.5	'SWITCH 2749 - WILDORADO 69KV CKT 1'	
FDNS	5	0 11G	G08_022	'FROM->TO'	'DEAF SMITH COUNTY INTERCHANGE - S-RANDLCO		350	0.21473	102.5	'SOUTHWEST PORTLAND CEMENT TAP - SWITCH 2749 69KV CK	
FDNS	5	0 11G	G08_022	'FROM->TO'	'DEAF SMITH COUNTY INTERCHANGE - S-RANDLCO		350	0.21473	102.5	'NORTHWEST TAP - SOUTHWEST PORTLAND CEMENT TAP 69K	
FDNS	5	0 11G	G08_022	'FROM->TO'	'DEAF SMITH COUNTY INTERCHANGE - S-RANDLCO		350	0.21473	102.5	'MAJESTC_WND3115.00 - MARTIN 3115.00 115KV CKT 1'	
FDNS	5	0 11G	G08_022	'FROM->TO'	'DEAF SMITH COUNTY INTERCHANGE - S-RANDLCO		350	0.21473	102	'Golden Spread REC - Mustang Interchange 230 kV Generation Bus -	
FDNS	5	0 11G	G08_022	'FROM->TO'	'DEAF SMITH COUNTY INTERCHANGE - S-RANDLCO		350	0.21473	102.1	'G03-013 345.00 - STEVENSCO 345.00 345KV CKT 1'	
FDNS	5	0 11G	G08_022	'FROM->TO'	'DEAF SMITH COUNTY INTERCHANGE - S-RANDLCO		350	0.21473	100.7	'2008-047 TP345.00 - G08-47 345.00 345KV CKT 1'	
FDNS	5	0 11G	G08_022	'FROM->TO'	'DEAF SMITH COUNTY INTERCHANGE - S-RANDLCO		350	0.21473	103.9	'G05-15T 345.00 - G08-14 345.00 345KV CKT 1'	
FDNS	5	0 11G	G08_022	'FROM->TO'	'DEAF SMITH COUNTY INTERCHANGE - S-RANDLCO		350	0.21473	103.9	'G10-07 115.00 - G10-07T 115.00 115KV CKT 1'	
FDNS	5	0 11G	G08_022	'FROM->TO'	'DEAF SMITH COUNTY INTERCHANGE - S-RANDLCO		350	0.21473	103.9	'G05-15 345.00 - G05-15T 345.00 345KV CKT 1'	
FDNS	5	0 11G	G08_022	'FROM->TO'	'DEAF SMITH COUNTY INTERCHANGE - S-RANDLCO		350	0.21473	103.8	'G05-17 345.00 345/115KV TRANSFORMER CKT 1'	
FDNS	5	0 11G	G08_022	'FROM->TO'	'DEAF SMITH COUNTY INTERCHANGE - S-RANDLCO		350	0.21473	103.8	'G05-17-2 115.00 - G05-17-2 115.00 115KV CKT 1'	
FDNS	5	0 11G	G08_022	'FROM->TO'	'DEAF SMITH COUNTY INTERCHANGE - S-RANDLCO		350	0.21473	104.3	'G06-44 115.00 - G06-44-1 115.00 115KV CKT 1'	
FDNS	5	0 11G	G08_022	'FROM->TO'	'DEAF SMITH COUNTY INTERCHANGE - S-RANDLCO		350	0.21473	103.1	'G06-44 115.00 - G06-44-2 115.00 115KV CKT 1'	
FDNS	5	0 11G	G08_022	'FROM->TO'	'DEAF SMITH COUNTY INTERCHANGE - S-RANDLCO		350	0.21473	102.3	'G06-44 115.00 - G06-44-3 115.00 115KV CKT 1'	
FDNS	5	0 11G	G08_022	'FROM->TO'	'DEAF SMITH COUNTY INTERCHANGE - S-RANDLCO		350	0.21473	100.6	'Hitchland Interchange 345/0.575KV TRANSFORMER CKT 1'	
FDNS	5	0 11G	G08_022	'FROM->TO'	'DEAF SMITH COUNTY INTERCHANGE - S-RANDLCO		350	0.21473	101.3	'Hitchland Interchange (PRO G2218-01) 345/115/13.8KV TRANSFOF	
FDNS	5	0 11G	G08_022	'FROM->TO'	'DEAF SMITH COUNTY INTERCHANGE - S-RANDLCO		350	0.21473	139.9	'TOLK STATION EAST 230/24.0KV TRANSFORMER CKT 1'	
FDNS	5	0 11G	G08_022	'FROM->TO'	'DEAF SMITH COUNTY INTERCHANGE - S-RANDLCO		350	0.21473	104.1	'JONES STATION 230/22.0KV TRANSFORMER CKT 1'	
FDNS	5	0 11G	G08_022	'FROM->TO'	'DEAF SMITH COUNTY INTERCHANGE - S-RANDLCO		350	0.21473	104.1	'Jones Station Bus#2 230/22.0KV TRANSFORMER CKT 1'	
FDNS	5	0 11G	G08_022	'FROM->TO'	'DEAF SMITH COUNTY INTERCHANGE - S-RANDLCO		350	0.21473	104	'GRASSLAND INTERCHANGE 230/34.5KV TRANSFORMER CKT 1'	
FDNS	5	0 11G	G08_022	'FROM->TO'	'DEAF SMITH COUNTY INTERCHANGE - S-RANDLCO		350	0.21473	104.2	'MUSTANG STATION N. 115/13.8KV TRANSFORMER CKT 1'	
FDNS	5	0 11G	G08_022	'FROM->TO'	'DEAF SMITH COUNTY INTERCHANGE - S-RANDLCO		350	0.21473	104.2	'MUSTANG STATION S. 115/13.8KV TRANSFORMER CKT 1'	
FDNS	5	0 11G	G08_022	'FROM->TO'	'DEAF SMITH COUNTY INTERCHANGE - S-RANDLCO		350	0.21473	104.2	'Golden Spread REC - Mustang Interchange 230 kV Generation Bus :	

SOLUTION GROUP	SCENARI	SEASON	SOURCE	DIRECTION	MONITORED ELEMENT COMMON NAME	RATEB	TDF	TC%	LOAD CONTINGENCY NAME
FDNS	5	0 11G	G08_022	'FROM->TO'	'DEAF SMITH COUNTY INTERCHANGE - S-RANDLCO	350	0.21473	103.7	'G03-013 345.00 345/34.5KV TRANSFORMER CKT 1'
FDNS	5	0 11G	G08_022	'FROM->TO'	'DEAF SMITH COUNTY INTERCHANGE - S-RANDLCO	350	0.21473	103.1	'G05-17 345.00 345/34.5KV TRANSFORMER CKT 1'
FDNS	5	0 11G	G08_022	'FROM->TO'	'DEAF SMITH COUNTY INTERCHANGE - S-RANDLCO	350	0.21473	103.1	'G05-17 345.00 345/34.5KV TRANSFORMER CKT 1'
FDNS	5	0 11G	G08_022	'FROM->TO'	'DEAF SMITH COUNTY INTERCHANGE - S-RANDLCO	350	0.21473	103.8	'G05-17-2 115.00 115/34.5KV TRANSFORMER CKT 1'
FDNS	5	0 11G	G08_022	'FROM->TO'	'DEAF SMITH COUNTY INTERCHANGE - S-RANDLCO	350	0.21473	104.3	'G06-44-1 115.00 115/34.5KV TRANSFORMER CKT 1'
FDNS	5	0 11G	G08_022	'FROM->TO'	'DEAF SMITH COUNTY INTERCHANGE - S-RANDLCO	350	0.21473	103.1	'G06-44-2 115.00 115/34.5KV TRANSFORMER CKT 1'
FDNS	5	0 11G	G08_022	'FROM->TO'	'DEAF SMITH COUNTY INTERCHANGE - S-RANDLCO	350	0.21473	102.3	'G06-44-3 115.00 115/34.5KV TRANSFORMER CKT 1'
FDNS	02ALL	0 11G	G08_022	'FROM->TO'	'DEAF SMITH COUNTY INTERCHANGE - S-RANDLCO	350	0.21167	101.9	'OKLAUN - OKLAUNION 345KV CKT 1'
FDNS	02ALL	0 11G	G08_022	'FROM->TO'	'DEAF SMITH COUNTY INTERCHANGE - S-RANDLCO	350	0.21167	133.6	'TOLK STATION EAST 230/24.0KV TRANSFORMER CKT 1'
FDNS	02ALL	0 11G	G08_022	'FROM->TO'	'DEAF SMITH COUNTY INTERCHANGE - S-RANDLCO	350	0.21167	101.9	'OKLAUN - OKLAUNION 345KV CKT 1'
FDNS	02ALL	0 11G	G08_022	'FROM->TO'	'DEAF SMITH COUNTY INTERCHANGE - S-RANDLCO	350	0.21167	133.6	'TOLK STATION EAST 230/24.0KV TRANSFORMER CKT 1'
FDNS	02ALL	0 11G	G08_022	'FROM->TO'	'DEAF SMITH COUNTY INTERCHANGE - S-RANDLCO	350	0.2139	104.8	'OKLAUN - OKLAUNION 345KV CKT 1'
FDNS	02ALL	0 11G	G08_022	'FROM->TO'	'DEAF SMITH COUNTY INTERCHANGE - S-RANDLCO	350	0.2139	98.6	'ASGI-10-11 69.000 - TRI COUNTY REC-TEXAS COUNTY INTERC
FDNS	02ALL	0 11G	G08_022	'FROM->TO'	'DEAF SMITH COUNTY INTERCHANGE - S-RANDLCO	350	0.2139	100.8	'HUBER GEN - INDUSTRIAL SUB 69KV CKT 1'
FDNS	02ALL	0 11G	G08_022	'FROM->TO'	'DEAF SMITH COUNTY INTERCHANGE - S-RANDLCO	350	0.2139	100.8	'INDUSTRIAL SUB - SID RICHARDSON (PHILLIPS) GEN 69KV CKT
FDNS	02ALL	0 11G	G08_022	'FROM->TO'	'DEAF SMITH COUNTY INTERCHANGE - S-RANDLCO	350	0.2139	96.2	'FINNEY SWITCHING STATION - G08-18 345.00 345KV CKT 1'
FDNS	02ALL	0 11G	G08_022	'FROM->TO'	'DEAF SMITH COUNTY INTERCHANGE - S-RANDLCO	350	0.2139	96.5	'G08-51 345.00 - POTTER COUNTY INTERCHANGE 345KV CKT
FDNS	02ALL	0 11G	G08_022	'FROM->TO'	'DEAF SMITH COUNTY INTERCHANGE - S-RANDLCO	350	0.2139	100.7	'G05-21 115.00 - KIRBY SWITCHING STATION 115KV CKT 1'
FDNS	02ALL	0 11G	G08_022	'FROM->TO'	'DEAF SMITH COUNTY INTERCHANGE - S-RANDLCO	350	0.2139	95.4	'BUSHLAND INTERCHANGE - WILDORADO WIND GEN 230KV CK
FDNS	02ALL	0 11G	G08_022	'FROM->TO'	'DEAF SMITH COUNTY INTERCHANGE - S-RANDLCO	350	0.2139	99.4	'Golden Spread REC - Mustang Interchange 230 kV Generation Bus
FDNS	02ALL	0 11G	G08_022	'FROM->TO'	'DEAF SMITH COUNTY INTERCHANGE - S-RANDLCO	350	0.2139	95.9	'G06-45 230.00 - S-RANDLCO 230.00 230KV CKT 1'
FDNS	02ALL	0 11G	G08_022	'FROM->TO'	'DEAF SMITH COUNTY INTERCHANGE - S-RANDLCO	350	0.2139	96	'G06-47 230.00 - S-RANDLCO 230.00 230KV CKT 1'
FDNS	02ALL	0 11G	G08_022	'FROM->TO'	'DEAF SMITH COUNTY INTERCHANGE - S-RANDLCO	350	0.2139	100.9	'G05-15T 345.00 - G08-14 345.00 345KV CKT 1'
FDNS	02ALL	0 11G	G08_022	'FROM->TO'	'DEAF SMITH COUNTY INTERCHANGE - S-RANDLCO	350	0.2139	96.1	'G10-07 115.00 - G10-07T 115.00 115KV CKT 1'
FDNS	02ALL	0 11G	G08_022	'FROM->TO'	'DEAF SMITH COUNTY INTERCHANGE - S-RANDLCO	350	0.2139	100.9	'G05-15 345.00 - G05-15T 345.00 345KV CKT 1'
FDNS	02ALL	0 11G	G08_022	'FROM->TO'	'DEAF SMITH COUNTY INTERCHANGE - S-RANDLCO	350	0.2139	95.7	'G05-17 345.00 345/115KV TRANSFORMER CKT 1'
FDNS	02ALL	0 11G	G08_022	'FROM->TO'	'DEAF SMITH COUNTY INTERCHANGE - S-RANDLCO	350	0.2139	95.7	'G05-17-2 115.00 - G05-17-2 115.00 115KV CKT 1'
FDNS	02ALL	0 11G	G08_022	'FROM->TO'	'DEAF SMITH COUNTY INTERCHANGE - S-RANDLCO	350	0.2139	98	'G06-44 115.00 - G06-44-1 115.00 115KV CKT 1'
FDNS	02ALL	0 11G	G08_022	'FROM->TO'	'DEAF SMITH COUNTY INTERCHANGE - S-RANDLCO	350	0.2139	101.2	'SHERMAN COUNTY SUB 115/34.5KV TRANSFORMER CKT 1'
FDNS	02ALL	0 11G	G08_022	'FROM->TO'	'DEAF SMITH COUNTY INTERCHANGE - S-RANDLCO	350	0.2139	100.6	'MOORE COUNTY INTERCHANGE EAST BUS 115/13.2KV TRANSI
FDNS	02ALL	0 11G	G08_022	'FROM->TO'	'DEAF SMITH COUNTY INTERCHANGE - S-RANDLCO	350	0.2139	101	'DUMAS SUB 115/34.5KV TRANSFORMER CKT 1'
FDNS	02ALL	0 11G	G08_022	'FROM->TO'	'DEAF SMITH COUNTY INTERCHANGE - S-RANDLCO	350	0.2139	97.2	'WILDORADO WIND GEN 230/34.5KV TRANSFORMER CKT 1'
FDNS	02ALL	0 11G	G08_022	'FROM->TO'	'DEAF SMITH COUNTY INTERCHANGE - S-RANDLCO	350	0.2139	138.2	'TOLK STATION EAST 230/24.0KV TRANSFORMER CKT 1'
FDNS	02ALL	0 11G	G08_022	'FROM->TO'	'DEAF SMITH COUNTY INTERCHANGE - S-RANDLCO	350	0.2139	101.2	'JONES STATION 230/22.0KV TRANSFORMER CKT 1'
FDNS	02ALL	0 11G	G08_022	'FROM->TO'	'DEAF SMITH COUNTY INTERCHANGE - S-RANDLCO	350	0.2139	101.2	'Jones Station Bus#2 230/22.0KV TRANSFORMER CKT 1'
FDNS	02ALL	0 11G	G08_022	'FROM->TO'	'DEAF SMITH COUNTY INTERCHANGE - S-RANDLCO	350	0.2139	100.9	'GRASSLAND INTERCHANGE 230/34.5KV TRANSFORMER CKT 1'
FDNS	02ALL	0 11G	G08_022	'FROM->TO'	'DEAF SMITH COUNTY INTERCHANGE - S-RANDLCO	350	0.2139	101.1	'MUSTANG STATION N. 115/13.8KV TRANSFORMER CKT 1'
FDNS	02ALL	0 11G	G08_022	'FROM->TO'	'DEAF SMITH COUNTY INTERCHANGE - S-RANDLCO	350	0.2139	101.1	'MUSTANG STATION S. 115/13.8KV TRANSFORMER CKT 1'
FDNS	02ALL	0 11G	G08_022	'FROM->TO'	'DEAF SMITH COUNTY INTERCHANGE - S-RANDLCO	350	0.2139	101.1	'Golden Spread REC - Mustang Interchange 230 kV Generation Bus
FDNS	02ALL	0 11G	G08_022	'FROM->TO'	'DEAF SMITH COUNTY INTERCHANGE - S-RANDLCO	350	0.2139	101.2	'Golden Spread REC - Mustang Interchange 230 kV Generation Bus
FDNS	02ALL	0 11G	G08_022	'FROM->TO'	'DEAF SMITH COUNTY INTERCHANGE - S-RANDLCO	350	0.2139	101.2	'Golden Spread REC - Mustang Interchange 230 kV Generation Bus
FDNS	02ALL	0 11G	G08_022	'FROM->TO'	'DEAF SMITH COUNTY INTERCHANGE - S-RANDLCO	350	0.2139	100.1	'HOLCOMB 115/22.0KV TRANSFORMER CKT 1'
FDNS	02ALL	0 11G	G08_022	'FROM->TO'	'DEAF SMITH COUNTY INTERCHANGE - S-RANDLCO	350	0.2139	96.5	'G07-48T 230.00 230/34.5KV TRANSFORMER CKT 1'
FDNS	02ALL	0 11G	G08_022	'FROM->TO'	'DEAF SMITH COUNTY INTERCHANGE - S-RANDLCO	350	0.2139	100.9	'G08-14 345.00 345/34.5KV TRANSFORMER CKT 1'
FDNS	02ALL	0 11G	G08_022	'FROM->TO'	'DEAF SMITH COUNTY INTERCHANGE - S-RANDLCO	350	0.2139	96.1	'G10-07 115.00 115/34.5KV TRANSFORMER CKT 1'
FDNS	02ALL	0 11G	G08_022	'FROM->TO'	'DEAF SMITH COUNTY INTERCHANGE - S-RANDLCO	350	0.2139	98.6	'ASGI-10-11 69.000 69/34.5KV TRANSFORMER CKT 1'
FDNS	02ALL	0 11G	G08_022	'FROM->TO'	'DEAF SMITH COUNTY INTERCHANGE - S-RANDLCO	350	0.2139	96.2	'G08-18 345.00 345/34.5KV TRANSFORMER CKT 1'
FDNS	02ALL	0 11G	G08_022	'FROM->TO'	'DEAF SMITH COUNTY INTERCHANGE - S-RANDLCO	350	0.2139	95	'G03-013 345.00 345/34.5KV TRANSFORMER CKT 1'
FDNS	02ALL	0 11G	G08_022	'FROM->TO'	'DEAF SMITH COUNTY INTERCHANGE - S-RANDLCO	350	0.2139	95	'G03-013 345.00 345/34.5KV TRANSFORMER CKT 1'
FDNS	02ALL	0 11G	G08_022	'FROM->TO'	'DEAF SMITH COUNTY INTERCHANGE - S-RANDLCO	350	0.2139	95.7	'G05-17-2 115.00 115/34.5KV TRANSFORMER CKT 1'
FDNS	02ALL	0 11G	G08_022	'FROM->TO'	'DEAF SMITH COUNTY INTERCHANGE - S-RANDLCO	350	0.2139	100.7	'G05-21 115.00 115/34.5KV TRANSFORMER CKT 1'
FDNS	02ALL	0 11G	G08_022	'FROM->TO'	'DEAF SMITH COUNTY INTERCHANGE - S-RANDLCO	350	0.2139	98	'G06-44-1 115.00 115/34.5KV TRANSFORMER CKT 1'
FDNS	02ALL	0 11G	G08_022	'FROM->TO'	'DEAF SMITH COUNTY INTERCHANGE - S-RANDLCO	350	0.2139	95.9	'G06-45 230.00 230/34.5KV TRANSFORMER CKT 1'
FDNS	02ALL	0 11G	G08_022	'FROM->TO'	'DEAF SMITH COUNTY INTERCHANGE - S-RANDLCO	350	0.2139	95.9	'G06-47 230.00 230/34.5KV TRANSFORMER CKT 1'
FDNS	02ALL	2 11G	G08_022	'FROM->TO'	'DEAF SMITH COUNTY INTERCHANGE - S-RANDLCO	350	0.21107	123.2	'TOLK STATION EAST 230/24.0KV TRANSFORMER CKT 1'
FDNS	02ALL	3 11G	G08_022	'FROM->TO'	'DEAF SMITH COUNTY INTERCHANGE - S-RANDLCO	350	0.21177	120.8	'TOLK STATION EAST 230/24.0KV TRANSFORMER CKT 1'
FDNS	02G08110	0 11G	G08_022	'FROM->TO'	'DEAF SMITH COUNTY INTERCHANGE - S-RANDLCO	350	0.2126	122.2	'TOLK STATION EAST 230/24.0KV TRANSFORMER CKT 1'
FDNS	02G08110	0 11G	G08_022	'TO->FROM'	'FINNEY SWITCHING STATION - STEVENSCO 345.00	1052	0.19859	132.1299	'DBL-HIT-G084'
FDNS	02G08110	2 11G	G08_022	'FROM->TO'	'DEAF SMITH COUNTY INTERCHANGE - S-RANDLCO	350	0.20995	109.8	'TOLK STATION EAST 230/24.0KV TRANSFORMER CKT 1'
FDNS	02G08110	3 11G	G08_022	'FROM->TO'	'DEAF SMITH COUNTY INTERCHANGE - S-RANDLCO	350	0.21071	108.1	'TOLK STATION EAST 230/24.0KV TRANSFORMER CKT 1'
FDNS	02G0847	0 11G	G08_022	'FROM->TO'	'DEAF SMITH COUNTY INTERCHANGE - S-RANDLCO	350	0.21275	121.9	'TOLK STATION EAST 230/24.0KV TRANSFORMER CKT 1'
FDNS	02G0847	0 11G	G08_022	'TO->FROM'	'FINNEY SWITCHING STATION - STEVENSCO 345.00	1052	0.19982	128.0221	'DBL-HIT-G084'
FDNS	02G0847	2 11G	G08_022	'FROM->TO'	'DEAF SMITH COUNTY INTERCHANGE - S-RANDLCO	350	0.21011	109.5	'TOLK STATION EAST 230/24.0KV TRANSFORMER CKT 1'
FDNS	02G0847	3 11G	G08_022	'FROM->TO'	'DEAF SMITH COUNTY INTERCHANGE - S-RANDLCO	350	0.21086	107.7	'TOLK STATION EAST 230/24.0KV TRANSFORMER CKT 1'
FDNS	02G1007	0 11G	G08_022	'FROM->TO'	'DEAF SMITH COUNTY INTERCHANGE - S-RANDLCO	350	0.21266	121	'TOLK STATION EAST 230/24.0KV TRANSFORMER CKT 1'
FDNS	02G1007	0 11G	G08_022	'TO->FROM'	'FINNEY SWITCHING STATION - STEVENSCO 345.00	1052	0.1995	128.8406	'DBL-HIT-G084'

SOLUTION GROUP	SCENARI	SEASON	SOURCE	DIRECTION	MONITORED ELEMENT	COMMON NAME	RATEB	TDF	TC%	LOAD	CONTINGENCY	NAME
FDNS	02G1007	2	11G	G08_022	'FROM->TO'	'DEAF SMITH COUNTY INTERCHANGE - S-RANDLCO	350	0.21003	108.9	'TOLK STATION EAST 230/24.0KV TRANSFORMER CKT 1'		
FDNS	02G1007	3	11G	G08_022	'FROM->TO'	'DEAF SMITH COUNTY INTERCHANGE - S-RANDLCO	350	0.21008	107.1	'TOLK STATION EAST 230/24.0KV TRANSFORMER CKT 1'		
FDNS	02G1014	0	11G	G08_022	'FROM->TO'	'DEAF SMITH COUNTY INTERCHANGE - S-RANDLCO	350	0.21271	121.8	'TOLK STATION EAST 230/24.0KV TRANSFORMER CKT 1'		
FDNS	02G1014	0	11G	G08_022	'TO->FROM'	'FINNEY SWITCHING STATION - STEVENSCO 345.00	1052	0.19838	133.3729	'DBL-HIT-G084'		
FDNS	02G1014	2	11G	G08_022	'FROM->TO'	'DEAF SMITH COUNTY INTERCHANGE - S-RANDLCO	350	0.21006	109.3	'TOLK STATION EAST 230/24.0KV TRANSFORMER CKT 1'		
FDNS	02G1014	3	11G	G08_022	'FROM->TO'	'DEAF SMITH COUNTY INTERCHANGE - S-RANDLCO	350	0.21082	107.6	'TOLK STATION EAST 230/24.0KV TRANSFORMER CKT 1'		
FDNS	2	0	11G	G08_022	'FROM->TO'	'DEAF SMITH COUNTY INTERCHANGE - S-RANDLCO	350	0.21263	120.7	'TOLK STATION EAST 230/24.0KV TRANSFORMER CKT 1'		
FDNS	2	0	11G	G08_022	'TO->FROM'	'FINNEY SWITCHING STATION - STEVENSCO 345.00	1052	0.19971	128.0433	'DBL-HIT-G084'		
FDNS	2	2	11G	G08_022	'FROM->TO'	'DEAF SMITH COUNTY INTERCHANGE - S-RANDLCO	350	0.21001	108.6	'TOLK STATION EAST 230/24.0KV TRANSFORMER CKT 1'		
FDNS	2	3	11G	G08_022	'FROM->TO'	'DEAF SMITH COUNTY INTERCHANGE - S-RANDLCO	350	0.21078	106.9	'TOLK STATION EAST 230/24.0KV TRANSFORMER CKT 1'		
FNSL-Itera 02ALL		0	11G	G08_022		Non Converged	0	0.17125	9999	'SPP-SWPS-03'		
FNSL-Itera 02ALL		0	11G	G08_022		Non Converged	0	0.13217	9999	'DBL-HIT-G084'		
FNSL-Itera 02ALL		0	11G	G08_022		Non Converged	0	0.11946	9999	'DBL-G0847-WO'		
FNSL-Itera 02ALL		0	11G	G08_022		Non Converged	0	0.09489	9999	'SPP-SWPS-03'		
FNSL-Itera 02ALL		0	11G	G08_022		Non Converged	0	0.08064	9999	'ATC_B2_8E2_G'		
FNSL-Itera 02ALL		0	11G	G08_022		Non Converged	0	0.0783	9999	'050 1'		
FNSL-Itera 02ALL		0	11G	G08_022		Non Converged	0	0.07558	9999	'ATC_B2_8E2'		
FNSL-Itera 02ALL		0	11G	G08_022		Non Converged	0	0.07529	9999	'ATC_B2_8E2'		
FNSL-Itera 02ALL		0	11G	G08_022		Non Converged	0	0.07376	9999	'050 2'		
FNSL-Itera 02ALL		0	11G	G08_022		Non Converged	441	0.06345	56.03129	'STLN-DEMARC6230.00 - SWEETWT6 230.00 230KV CKT 1'		
FNSL-Blow 02ALL		0	11G	G08_022		Non Converged	192	0.05316	19.07647	'ALTUS JCT TAP - ALTUS JUNCTION 138KV CKT 1'		
FNSL-Itera 02ALL		0	11G	G08_022		Non Converged	0	0.05105	9999	'ATC_B2_8E2'		
FNSL-Itera 02ALL		0	11G	G08_022		Non Converged	0	0.04962	9999	'050 2'		
FNSL-Itera 02ALL		0	11G	G08_022		Non Converged	441	0.04144	56.87944	'STATELINE INTERCHANGE - STLN-DEMARC6230.00 230KV CKT		
FNSL-Itera 02ALL		0	11G	G08_022		Non Converged	0	0.03144	9999	'ATC_B2_8E2_G'		
FNSL-Itera 02ALL		0	11G	G08_022		Non Converged	0	0.02978	9999	'050 1'		
FNSL-Itera 02ALL		0	11G	G08_022		Non Converged	0	0.02783	9999	'050 2'		
FNSL-Itera 02ALL		0	11G	G08_022		Non Converged	0	0.02347	9999	'ATC_B2_8E2_G'		
FNSL-Itera 02ALL		0	11G	G08_022		Non Converged	0	0.02235	9999	'050 1'		
FNSL-Itera 02ALL		0	11G	G08_022		Non Converged	441	0.022	57.29366	'STLN-DEMARC6230.00 - SWEETWT6 230.00 230KV CKT 1'		
FNSL-Blow 02ALL		0	11G	G08_022		Non Converged	1052	0.11419	97.33807	'FINNEY SWITCHING STATION - STEVENSCO 345.00 345KV CKT		
FNSL-Blow 02ALL		0	11G	G08_022		Non Converged	0	0.13217	9999	'DBL-HIT-G084'		
FNSL-Blow 02ALL		0	11G	G08_022		Non Converged	0	0.11061	9999	'DBL-G0847-WO'		
FNSL-Itera 02ALL		0	11G	G08_022		Non Converged	0	0.04572	9999	'SPP-SWPS-T53'		
FNSL-Itera 02ALL		2	11G	G08_022		Non Converged	1052	0.1219	82.65054	'FINNEY SWITCHING STATION - STEVENSCO 345.00 345KV CKT		
FNSL-Itera 02ALL		2	11G	G08_022		Non Converged	0	0.13982	9999	'DBL-G0847-WO'		
FNSL-Blow 02G08110		0	11G	G08_022		Non Converged	0	0.12318	9999	'DBL-G0847-WO'		
FNSL-Itera 02G08110		0	11G	G08_022		Non Converged	0	0.14287	9999	'SPP-SWPS-02'		
FNSL-Itera 02G08110		0	11G	G08_022		Non Converged	441	0.07144	56.82947	'STLN-DEMARC6230.00 - SWEETWT6 230.00 230KV CKT 1'		
FNSL-Itera 02G08110		0	11G	G08_022		Non Converged	441	0.07144	57.15012	'STATELINE INTERCHANGE - STLN-DEMARC6230.00 230KV CKT		
FNSL-Itera 02G08110		3	11G	G08_022		Non Converged	0	0.12916	9999	'SPP-SWPS-03'		
FNSL-Itera 02G0847		0	11G	G08_022		Non Converged	441	0.07141	57.61415	'STATELINE INTERCHANGE - STLN-DEMARC6230.00 230KV CKT		
FNSL-Itera 02G0847		0	11G	G08_022		Non Converged	0	0.12149	9999	'DBL-G0847-WO'		
FNSL-Itera 02G0847		0	11G	G08_022		Non Converged	0	0.14281	9999	'SPP-SWPS-02'		
FNSL-Itera 02G0847		0	11G	G08_022		Non Converged	441	0.07141	57.29366	'STLN-DEMARC6230.00 - SWEETWT6 230.00 230KV CKT 1'		
FNSL-Itera 02G0847		0	11G	G08_022		Non Converged	351	0.06555	82.03278	'GRAPEVINE INTERCHANGE - NICHOLS STATION 230KV CKT 1'		
FNSL-Itera 02G0847		3	11G	G08_022		Non Converged	0	0.12913	9999	'SPP-SWPS-03'		
FNSL-Itera 02G1007		0	11G	G08_022		Non Converged	441	0.07146	56.55862	'STLN-DEMARC6230.00 - SWEETWT6 230.00 230KV CKT 1'		
FNSL-Itera 02G1007		0	11G	G08_022		Non Converged	441	0.07146	56.87944	'STATELINE INTERCHANGE - STLN-DEMARC6230.00 230KV CKT		
FNSL-Itera 02G1007		0	11G	G08_022		Non Converged	1052	0.12226	77.23053	'FINNEY SWITCHING STATION - STEVENSCO 345.00 345KV CKT		
FNSL-Itera 02G1007		0	11G	G08_022		Non Converged	0	0.12401	9999	'DBL-G0847-WO'		
FNSL-Itera 02G1007		0	11G	G08_022		Non Converged	0	0.14291	9999	'SPP-SWPS-02'		
FNSL-Itera 02G1007		2	11G	G08_022		Non Converged	0	0.15031	9999	'DBL-G0847-WO'		
FNSL-Itera 02G1007		3	11G	G08_022		Non Converged	0	0.12917	9999	'SPP-SWPS-03'		
FNSL-Itera 02G1014		0	11G	G08_022		Non Converged	0	0.12296	9999	'DBL-G0847-WO'		
FNSL-Itera 02G1014		0	11G	G08_022		Non Converged	0	0.14279	9999	'SPP-SWPS-02'		
FNSL-Itera 02G1014		0	11G	G08_022		Non Converged	441	0.07139	57.2667	'STLN-DEMARC6230.00 - SWEETWT6 230.00 230KV CKT 1'		
FNSL-Itera 02G1014		0	11G	G08_022		Non Converged	351	0.06554	81.98898	'GRAPEVINE INTERCHANGE - NICHOLS STATION 230KV CKT 1'		
FNSL-Itera 02G1014		0	11G	G08_022		Non Converged	441	0.07139	57.58744	'STATELINE INTERCHANGE - STLN-DEMARC6230.00 230KV CKT		
FNSL-Itera 02G1014		3	11G	G08_022		Non Converged	0	0.12911	9999	'SPP-SWPS-03'		
FNSL-Itera 2		0	11G	G08_022		Non Converged	441	0.07152	56.03129	'STLN-DEMARC6230.00 - SWEETWT6 230.00 230KV CKT 1'		
FNSL-Itera 2		0	11G	G08_022		Non Converged	441	0.07152	56.34883	'STATELINE INTERCHANGE - STLN-DEMARC6230.00 230KV CKT		
FNSL-Itera 2		0	11G	G08_022		Non Converged	1052	0.12237	76.82405	'FINNEY SWITCHING STATION - STEVENSCO 345.00 345KV CKT		
FNSL-Blow 2		0	11G	G08_022		Non Converged	0	0.12419	9999	'DBL-G0847-WO'		
FNSL-Itera 2		0	11G	G08_022		Non Converged	0	0.14304	9999	'SPP-SWPS-02'		
FNSL-Itera 2		2	11G	G08_022		Non Converged	0	0.15046	9999	'DBL-G0847-WO'		
FNSL-Itera 2		3	11G	G08_022		Non Converged	0	0.12927	9999	'SPP-SWPS-03'		

SOLUTION GROUP	SCENARIK	SEASON	SOURCE	DIRECTION	MONITORED ELEMENT	COMMON NAME	RATEB	TDF	TC%	LOAD	CONTINGENCY	NAME
FNSL-Blow	03ALL	0 11G	G08_022		Non Converged		0	0.1289	9999	'DBL-MEDLO-WI'		
FNSL-Itera	06G0822	0 11G	G08_022		Non Converged		0	0.14104	9999	'SPP-SWPS-03'		
FNSL-Itera	6	0 11G	G08_022		Non Converged		0	0.14139	9999	'SPP-SWPS-03'		
FDNS	7	0 11G	G08_037	'TO->FROM'	'SOUTHWESTERN STATION - WASHITA 138KV CKT 1'		260	0.49528	107.3589	'BASE CASE'		
FDNS	7	0 11G	G08_037	'FROM->TO'	'G08-37T 138.00 - WASHITA 138KV CKT 1'		324	0.99066	108.0115	'BASE CASE'		
FDNS	7	0 11G	G08_037	'TO->FROM'	'GRACMNT4 138.00 - WASHITA 138KV CKT 1'		228	0.78734	146.7726	'SOUTHWESTERN STATION - WASHITA 138KV CKT 1'		
FDNS	7	0 11G	G08_037	'TO->FROM'	'SOUTHWESTERN STATION - WASHITA 138KV CKT 1'		260	0.82546	134.8215	'GRACMNT4 138.00 - WASHITA 138KV CKT 1'		
FDNS	7	0 11G	G08_037	'TO->FROM'	'SOUTHWESTERN STATION - WASHITA 138KV CKT 1'		260	0.62418	105.7635	'GRACMNT7 345.00 (BANK 1) 345/138/13.8KV TRANSFORMER C		
FDNS	7	0 11G	G08_037	'TO->FROM'	'SOUTHWESTERN STATION - WASHITA 138KV CKT 1'		260	0.49528	107.3589	'BASE CASE'		
FDNS	7	0 11G	G08_037	'FROM->TO'	'G08-37T 138.00 - WASHITA 138KV CKT 1'		324	0.99066	108.0115	'BASE CASE'		
FDNS	7	0 11G	G08_037	'TO->FROM'	'GRACMNT4 138.00 - WASHITA 138KV CKT 1'		228	0.78734	146.7726	'SOUTHWESTERN STATION - WASHITA 138KV CKT 1'		
FDNS	7	0 11G	G08_037	'TO->FROM'	'SOUTHWESTERN STATION - WASHITA 138KV CKT 1'		260	0.82546	134.8215	'GRACMNT4 138.00 - WASHITA 138KV CKT 1'		
FDNS	7	0 11G	G08_037	'TO->FROM'	'SOUTHWESTERN STATION - WASHITA 138KV CKT 1'		260	0.62418	105.7635	'GRACMNT7 345.00 (BANK 1) 345/138/13.8KV TRANSFORMER C		
FDNS	7	2 11G	G08_037	'TO->FROM'	'SOUTHWESTERN STATION - WASHITA 138KV CKT 1'		260	0.39797	98.1	'BASE CASE'		
FDNS	7	2 11G	G08_037	'TO->FROM'	'SOUTHWESTERN STATION - WASHITA 138KV CKT 1'		260	0.56422	108.5521	'GRACMNT7 345.00 (BANK 1) 345/138/13.8KV TRANSFORMER C		
FDNS	7	2 11G	G08_037	'TO->FROM'	'SOUTHWESTERN STATION - WASHITA 138KV CKT 1'		260	0.39797	98.1	'BASE CASE'		
FDNS	7	2 11G	G08_037	'TO->FROM'	'SOUTHWESTERN STATION - WASHITA 138KV CKT 1'		260	0.56422	108.5521	'GRACMNT7 345.00 (BANK 1) 345/138/13.8KV TRANSFORMER C		
FDNS	07G0837	0 11G	G08_037	'TO->FROM'	'SOUTHWESTERN STATION - WASHITA 138KV CKT 1'		260	0.49492	113.0367	'BASE CASE'		
FDNS	07G0837	0 11G	G08_037	'FROM->TO'	'G08-37T 138.00 - WASHITA 138KV CKT 1'		324	0.98995	117.0937	'BASE CASE'		
FDNS	07G0837	0 11G	G08_037	'TO->FROM'	'GRACMNT4 138.00 - WASHITA 138KV CKT 1'		228	0.78677	154.9554	'SOUTHWESTERN STATION - WASHITA 138KV CKT 1'		
FDNS	07G0837	0 11G	G08_037	'TO->FROM'	'SOUTHWESTERN STATION - WASHITA 138KV CKT 1'		260	0.82486	142.1908	'GRACMNT4 138.00 - WASHITA 138KV CKT 1'		
FDNS	07G0837	0 11G	G08_037	'TO->FROM'	'SOUTHWESTERN STATION - WASHITA 138KV CKT 1'		260	0.62372	111.263	'GRACMNT7 345.00 (BANK 1) 345/138/13.8KV TRANSFORMER C		
FDNS	07G0837	0 11G	G08_037	'TO->FROM'	'SOUTHWESTERN STATION - WASHITA 138KV CKT 1'		260	0.49492	113.0367	'BASE CASE'		
FDNS	07G0837	0 11G	G08_037	'FROM->TO'	'G08-37T 138.00 - WASHITA 138KV CKT 1'		324	0.98995	117.0937	'BASE CASE'		
FDNS	07G0837	0 11G	G08_037	'TO->FROM'	'GRACMNT4 138.00 - WASHITA 138KV CKT 1'		228	0.78677	154.9554	'SOUTHWESTERN STATION - WASHITA 138KV CKT 1'		
FDNS	07G0837	0 11G	G08_037	'TO->FROM'	'SOUTHWESTERN STATION - WASHITA 138KV CKT 1'		260	0.82486	142.1908	'GRACMNT4 138.00 - WASHITA 138KV CKT 1'		
FDNS	07G0837	2 11G	G08_037	'TO->FROM'	'SOUTHWESTERN STATION - WASHITA 138KV CKT 1'		260	0.62372	111.263	'GRACMNT7 345.00 (BANK 1) 345/138/13.8KV TRANSFORMER C		
FDNS	07G0837	2 11G	G08_037	'TO->FROM'	'SOUTHWESTERN STATION - WASHITA 138KV CKT 1'		260	0.39156	105.8118	'BASE CASE'		
FDNS	07G0837	2 11G	G08_037	'TO->FROM'	'SOUTHWESTERN STATION - WASHITA 138KV CKT 1'		260	0.56632	110.4461	'GRACMNT7 345.00 (BANK 1) 345/138/13.8KV TRANSFORMER C		
FDNS	07G0837	2 11G	G08_037	'TO->FROM'	'SOUTHWESTERN STATION - WASHITA 138KV CKT 1'		260	0.39156	105.8118	'BASE CASE'		
FDNS	07G0837	2 11G	G08_037	'TO->FROM'	'SOUTHWESTERN STATION - WASHITA 138KV CKT 1'		260	0.56632	110.4461	'GRACMNT7 345.00 (BANK 1) 345/138/13.8KV TRANSFORMER C		
FNSL-Itera	02ALL	0 11G	G08_037		Non Converged		1052	0.14352	77.23053	'FINNEY SWITCHING STATION - STEVENSCO 345.00 345KV CK'		
FNSL-Itera	02ALL	0 11G	G08_037		Non Converged		0	0.12673	9999	'SPP-SWPS-02'		
FNSL-Itera	02ALL	0 11G	G08_037		Non Converged		1052	0.11419	97.33807	'FINNEY SWITCHING STATION - STEVENSCO 345.00 345KV CK'		
FNSL-Itera	02ALL	0 11G	G08_037		Non Converged		0	0.08274	9999	'SPP-SWPS-02'		
FNSL-Itera	02ALL	0 11G	G08_037		Non Converged		0	0.08059	9999	'ATC_B2_8E2_G'		
FNSL-Itera	02ALL	0 11G	G08_037		Non Converged		0	0.0782	9999	'050 1'		
FNSL-Itera	02ALL	0 11G	G08_037		Non Converged		0	0.07548	9999	'ATC_B2_8E2'		
FNSL-Itera	02ALL	0 11G	G08_037		Non Converged		0	0.07381	9999	'050 2'		
FNSL-Itera	02ALL	0 11G	G08_037		Non Converged		441	0.07139	57.2667	'STLN-DEMARC6230.00 - SWEETWT6 230.00 230KV CKT 1'		
FNSL-Itera	02ALL	0 11G	G08_037		Non Converged		0	0.05482	9999	'ATC_B2_8E2_G'		
FNSL-Blow	02ALL	0 11G	G08_037		Non Converged		0	0.05289	9999	'050 1'		
FNSL-Itera	02ALL	0 11G	G08_037		Non Converged		0	0.05092	9999	'ATC_B2_8E2'		
FNSL-Itera	02ALL	0 11G	G08_037		Non Converged		0	0.04	9999	'SPP-SWPS-02'		
FNSL-Itera	02ALL	0 11G	G08_037		Non Converged		0	0.04003	9999	'DBL-G0847-WO'		
FNSL-Itera	02ALL	0 11G	G08_037		Non Converged		0	0.03012	9999	'050 1'		
FNSL-Itera	02ALL	0 11G	G08_037		Non Converged		0	0.02892	9999	'ATC_B2_8E2'		
FNSL-Itera	02ALL	0 11G	G08_037		Non Converged		1052	0.02576	76.82405	'FINNEY SWITCHING STATION - STEVENSCO 345.00 345KV CK'		
FNSL-Itera	02ALL	0 11G	G08_037		Non Converged		0	0.02317	9999	'ATC_B2_8E2_G'		
FNSL-Itera	02ALL	0 11G	G08_037		Non Converged		441	0.02212	56.34883	'STATELINE INTERCHANGE - STLN-DEMARC6230.00 230KV CKT		
FNSL-Itera	02ALL	0 11G	G08_037		Non Converged		0	0.02181	9999	'ATC_B2_8E2'		
FDNS	1	0 11G	G08_044	'TO->FROM'	'NORTHWEST - TATONGA7 345.00 345KV CKT 1'		1195	0.48872	104.2029	'DBL-MEDLO-WI'		
FDNS	1	0 11G	G08_044	'TO->FROM'	'NORTHWEST - TATONGA7 345.00 345KV CKT 1'		1195	0.48872	104.2029	'DBL-MEDLO-WI'		
FDNS	1	2 11G	G08_044	'TO->FROM'	'NORTHWEST - TATONGA7 345.00 345KV CKT 1'		1195	0.51046	95.8	'DBL-WOOD-MED'		
FDNS	1	2 11G	G08_044	'TO->FROM'	'NORTHWEST - TATONGA7 345.00 345KV CKT 1'		1195	0.51046	95.8	'DBL-WOOD-MED'		
FDNS	02ALL	0 11G	G08_044	'TO->FROM'	'NORTHWEST - TATONGA7 345.00 345KV CKT 1'		1195	0.49492	103.8577	'DBL-MEDLO-WI'		
FDNS	02ALL	0 11G	G08_044	'TO->FROM'	'NORTHWEST - TATONGA7 345.00 345KV CKT 1'		1195	0.49492	103.8577	'DBL-MEDLO-WI'		
FDNS	01G0844	0 11G	G08_044	'TO->FROM'	'NORTHWEST - TATONGA7 345.00 345KV CKT 1'		1195	0.48803	106.1849	'DBL-MEDLO-WI'		
FDNS	01G0844	0 11G	G08_044	'TO->FROM'	'NORTHWEST - TATONGA7 345.00 345KV CKT 1'		1195	0.48803	106.1849	'DBL-MEDLO-WI'		
FDNS	01G0844	2 11G	G08_044	'TO->FROM'	'NORTHWEST - TATONGA7 345.00 345KV CKT 1'		1195	0.51046	96.6	'DBL-WOOD-MED'		
FDNS	01G0844	2 11G	G08_044	'TO->FROM'	'NORTHWEST - TATONGA7 345.00 345KV CKT 1'		1195	0.51046	96.6	'DBL-WOOD-MED'		
FDNS	02ALL	0 11G	G08_044	'TO->FROM'	'NORTHWEST - TATONGA7 345.00 345KV CKT 1'		1195	0.4555	95.8	'LAWTON EASTSIDE - OKLAUNION 345KV CKT 1'		
FDNS	02ALL	0 11G	G08_044	'TO->FROM'	'NORTHWEST - TATONGA7 345.00 345KV CKT 1'		1195	0.48538	109.8945	'DBL-MEDLO-WI'		
FDNS	02ALL	0 11G	G08_044	'TO->FROM'	'NORTHWEST - TATONGA7 345.00 345KV CKT 1'		1195	0.53368	108.4191	'DBL-WOOD-MED'		
FDNS	02ALL	2 11G	G08_044	'TO->FROM'	'NORTHWEST - TATONGA7 345.00 345KV CKT 1'		1195	0.45357	98	'LAWTON EASTSIDE - OKLAUNION 345KV CKT 1'		
FDNS	02ALL	2 11G	G08_044	'TO->FROM'	'NORTHWEST - TATONGA7 345.00 345KV CKT 1'		1195	0.48417	112.085	'DBL-MEDLO-WI'		
FDNS	02ALL	2 11G	G08_044	'TO->FROM'	'NORTHWEST - TATONGA7 345.00 345KV CKT 1'		1195	0.52922	112.4579	'DBL-WOOD-MED'		

SOLUTION GROUP	SCENARI	SEASON	SOURCE	DIRECTION	MONITORED ELEMENT	COMMON NAME	RATEB	TDF	TC%	LOAD	CONTINGENCY	NAME	
FDNS	02G08110	0	11G	G08_044	'TO->FROM'	'NORTHWEST - TATONGA7	345.00	345KV	CKT 1'	1195	0.49199	95.7	'DBL-MEDLO-WI'
FDNS	02G08110	0	11G	G08_044	'TO->FROM'	'NORTHWEST - TATONGA7	345.00	345KV	CKT 1'	1195	0.54078	95.1	'DBL-WOOD-MED'
FDNS	02G08110	2	11G	G08_044	'TO->FROM'	'NORTHWEST - TATONGA7	345.00	345KV	CKT 1'	1195	0.49085	97.3	'DBL-MEDLO-WI'
FDNS	02G08110	2	11G	G08_044	'TO->FROM'	'NORTHWEST - TATONGA7	345.00	345KV	CKT 1'	1195	0.53651	98	'DBL-WOOD-MED'
FDNS	02G0847	0	11G	G08_044	'TO->FROM'	'NORTHWEST - TATONGA7	345.00	345KV	CKT 1'	1195	0.49137	97.4	'DBL-MEDLO-WI'
FDNS	02G0847	0	11G	G08_044	'TO->FROM'	'NORTHWEST - TATONGA7	345.00	345KV	CKT 1'	1195	0.54001	97.1	'DBL-WOOD-MED'
FDNS	02G0847	2	11G	G08_044	'TO->FROM'	'NORTHWEST - TATONGA7	345.00	345KV	CKT 1'	1195	0.49023	99	'DBL-MEDLO-WI'
FDNS	02G0847	2	11G	G08_044	'TO->FROM'	'NORTHWEST - TATONGA7	345.00	345KV	CKT 1'	1195	0.53575	100	'DBL-WOOD-MED'
FDNS	02G1007	2	11G	G08_044	'TO->FROM'	'NORTHWEST - TATONGA7	345.00	345KV	CKT 1'	1195	0.49122	96.4	'DBL-MEDLO-WI'
FDNS	02G1007	2	11G	G08_044	'TO->FROM'	'NORTHWEST - TATONGA7	345.00	345KV	CKT 1'	1195	0.53694	96.9	'DBL-WOOD-MED'
FDNS	02G1014	0	11G	G08_044	'TO->FROM'	'NORTHWEST - TATONGA7	345.00	345KV	CKT 1'	1195	0.49188	96	'DBL-MEDLO-WI'
FDNS	02G1014	0	11G	G08_044	'TO->FROM'	'NORTHWEST - TATONGA7	345.00	345KV	CKT 1'	1195	0.54066	95.4	'DBL-WOOD-MED'
FDNS	02G1014	2	11G	G08_044	'TO->FROM'	'NORTHWEST - TATONGA7	345.00	345KV	CKT 1'	1195	0.49073	97.6	'DBL-MEDLO-WI'
FDNS	02G1014	2	11G	G08_044	'TO->FROM'	'NORTHWEST - TATONGA7	345.00	345KV	CKT 1'	1195	0.53639	98.3	'DBL-WOOD-MED'
FDNS	2	2	11G	G08_044	'TO->FROM'	'NORTHWEST - TATONGA7	345.00	345KV	CKT 1'	1195	0.49133	96.1	'DBL-MEDLO-WI'
FDNS	2	2	11G	G08_044	'TO->FROM'	'NORTHWEST - TATONGA7	345.00	345KV	CKT 1'	1195	0.53707	96.5	'DBL-WOOD-MED'
FNSL-Itera 02ALL		0	11G	G08_044		Non Converged				1052	0.18928	82.65054	'FINNEY SWITCHING STATION - STEVENSCO 345.00 345KV CK'
FNSL-Itera 02ALL		0	11G	G08_044		Non Converged				0	0.14028	9999	'SPP-SWPS-02'
FNSL-Itera 02ALL		0	11G	G08_044		Non Converged				1052	0.12226	77.23053	'FINNEY SWITCHING STATION - STEVENSCO 345.00 345KV CK'
FNSL-Itera 02ALL		0	11G	G08_044		Non Converged				441	0.10561	57.15012	'STATELINE INTERCHANGE - STLN-DEMARC6230.00 230KV CKT
FNSL-Itera 02ALL		0	11G	G08_044		Non Converged				0	0.08072	9999	'ATC_B2_8E2_G'
FNSL-Itera 02ALL		0	11G	G08_044		Non Converged				0	0.07831	9999	'050 1'
FNSL-Itera 02ALL		0	11G	G08_044		Non Converged				0	0.07807	9999	'050 1'
FNSL-Itera 02ALL		0	11G	G08_044		Non Converged				0	0.07546	9999	'ATC_B2_8E2'
FNSL-Itera 02ALL		0	11G	G08_044		Non Converged				0	0.07378	9999	'050 2'
FNSL-Itera 02ALL		0	11G	G08_044		Non Converged				441	0.0701	57.2667	'STLN-DEMARC6230.00 - SWEETWT6 230.00 230KV CKT 1'
FNSL-Blow 02ALL		0	11G	G08_044		Non Converged				0	0.0548	9999	'ATC_B2_8E2_G'
FNSL-Itera 02ALL		0	11G	G08_044		Non Converged				0	0.05248	9999	'SPP-SWPS-03'
FNSL-Itera 02ALL		0	11G	G08_044		Non Converged				0	0.04964	9999	'050 2'
FNSL-Itera 02ALL		0	11G	G08_044		Non Converged				441	0.0415	56.03129	'STLN-DEMARC6230.00 - SWEETWT6 230.00 230KV CKT 1'
FNSL-Itera 02ALL		0	11G	G08_044		Non Converged				0	0.03154	9999	'ATC_B2_8E2_G'
FNSL-Itera 02ALL		0	11G	G08_044		Non Converged				0	0.02999	9999	'050 1'
FNSL-Itera 02ALL		0	11G	G08_044		Non Converged				0	0.02792	9999	'050 2'
FNSL-Itera 02ALL		0	11G	G08_044		Non Converged				0	0.02541	9999	'SPP-SWPS-03'
FNSL-Itera 02ALL		0	11G	G08_044		Non Converged				0	0.02261	9999	'050 1'
FNSL-Itera 02ALL		0	11G	G08_044		Non Converged				441	0.02203	56.82947	'STLN-DEMARC6230.00 - SWEETWT6 230.00 230KV CKT 1'
FNSL-Itera 02ALL		2	11G	G08_044		Non Converged				1052	0.03153	82.65054	'FINNEY SWITCHING STATION - STEVENSCO 345.00 345KV CK'
FNSL-Itera 02G1007		0	11G	G08_044		Non Converged				1052	0.03101	77.23053	'FINNEY SWITCHING STATION - STEVENSCO 345.00 345KV CK'
FNSL-Itera 2		0	11G	G08_044		Non Converged				1052	0.03112	76.82405	'FINNEY SWITCHING STATION - STEVENSCO 345.00 345KV CK'
FNSL-Blow 03ALL		0	11G	G08_044		Non Converged				0	0.11072	9999	'DBL-MEDLO-WI'
FNSL-Itera 02ALL		0	11G	G08_046		Non Converged				1052	0.17644	82.65054	'FINNEY SWITCHING STATION - STEVENSCO 345.00 345KV CK'
FNSL-Itera 02ALL		0	11G	G08_046		Non Converged				0	0.14019	9999	'SPP-SWPS-02'
FNSL-Itera 02ALL		0	11G	G08_046		Non Converged				0	0.12149	9999	'DBL-G0847-WO'
FNSL-Itera 02ALL		0	11G	G08_046		Non Converged				441	0.10557	57.29366	'STLN-DEMARC6230.00 - SWEETWT6 230.00 230KV CKT 1'
FNSL-Itera 02ALL		0	11G	G08_046		Non Converged				0	0.08071	9999	'ATC_B2_8E2_G'
FNSL-Itera 02ALL		0	11G	G08_046		Non Converged				0	0.07831	9999	'050 1'
FNSL-Itera 02ALL		0	11G	G08_046		Non Converged				0	0.07801	9999	'050 1'
FNSL-Itera 02ALL		0	11G	G08_046		Non Converged				0	0.07545	9999	'ATC_B2_8E2'
FNSL-Itera 02ALL		0	11G	G08_046		Non Converged				0	0.07378	9999	'050 2'
FNSL-Itera 02ALL		0	11G	G08_046		Non Converged				0	0.06709	9999	'SPP-SWPS-T53'
FNSL-Blow 02ALL		0	11G	G08_046		Non Converged				0	0.05467	9999	'ATC_B2_8E2_G'
FNSL-Itera 02ALL		0	11G	G08_046		Non Converged				0	0.05245	9999	'SPP-SWPS-03'
FNSL-Itera 02ALL		0	11G	G08_046		Non Converged				0	0.04963	9999	'050 2'
FNSL-Itera 02ALL		0	11G	G08_046		Non Converged				441	0.0415	56.34883	'STATELINE INTERCHANGE - STLN-DEMARC6230.00 230KV CKT
FNSL-Itera 02ALL		0	11G	G08_046		Non Converged				1052	0.03153	82.65054	'FINNEY SWITCHING STATION - STEVENSCO 345.00 345KV CK'
FNSL-Itera 02ALL		0	11G	G08_046		Non Converged				0	0.02997	9999	'050 1'
FNSL-Itera 02ALL		0	11G	G08_046		Non Converged				0	0.02791	9999	'050 2'
FNSL-Itera 02ALL		0	11G	G08_046		Non Converged				0	0.02538	9999	'SPP-SWPS-03'
FNSL-Itera 02ALL		0	11G	G08_046		Non Converged				0	0.02261	9999	'050 1'
FNSL-Itera 02ALL		0	11G	G08_046		Non Converged				441	0.02203	57.15012	'STATELINE INTERCHANGE - STLN-DEMARC6230.00 230KV CKT
FNSL-Itera 9		0	11G	G08_046		Non Converged				1052	0.03551	41.0985	'GEN509394 1-FLINT CREEK'
FNSL-Itera 9		2	11G	G08_046		Non Converged				1052	0.0355	41.10939	'GEN509394 1-FLINT CREEK'
FNSL-Itera 11		0	11G	G08_046		Non Converged				1052	0.03594	40.0801	'GEN509394 1-FLINT CREEK'
FNSL-Itera 11		2	11G	G08_046		Non Converged				1052	0.03594	40.07955	'GEN509394 1-FLINT CREEK'
FNSL-Itera 13		0	11G	G08_046		Non Converged				1052	0.03559	39.9714	'GEN509394 1-FLINT CREEK'
FNSL-Itera 15		0	11G	G08_046		Non Converged				1052	0.03536	41.50943	'GEN509394 1-FLINT CREEK'
FDNS	1	0	11G	G08_047	'TO->FROM'	'NORTHWEST - TATONGA7	345.00	345KV	CKT 1'	1195	0.22547	104.2029	'DBL-MEDLO-WI'

SOLUTION GROUP	SCENARI	SEASON	SOURCE	DIRECTION	MONITORED ELEMENT	COMMON NAME	RATEB	TDF	TC%	LOAD	CONTINGENCY	NAME
FDNS	1	0 11G	G08_047	TO->FROM'	'NORTHWEST - TATONGA7	345.00 345KV CKT 1'	1195	0.22547	104.2029		'DBL-MEDLO-WI'	
FDNS	1	2 11G	G08_047	TO->FROM'	'NORTHWEST - TATONGA7	345.00 345KV CKT 1'	1195	0.22495	95.8		'DBL-WOOD-MED'	
FDNS	1	2 11G	G08_047	TO->FROM'	'NORTHWEST - TATONGA7	345.00 345KV CKT 1'	1195	0.22495	95.8		'DBL-WOOD-MED'	
FNSL-Itera	2	0 11G	G08_047			Non Converged	0	0.60162	9999		'DBL-G0847-WO'	
FNSL-Itera	2	0 11G	G08_047			Non Converged	0	0.60162	9999		'DBL-G0847-WO'	
FNSL-Blow 02ALL		0 11G	G08_047			Non Converged	1052	0.26785	86.2944		'FINNEY SWITCHING STATION - STEVENSCO 345.00 345KV CK'	
FNSL-Blow 02ALL		0 11G	G08_047			Non Converged	0	0.2369	9999		'DBL-HIT-G084'	
FNSL-Blow 02ALL		0 11G	G08_047			Non Converged	0	0.2369	9999		'DBL-G0847-WO'	
FDNS 02ALL		0 11G	G08_047	TO->FROM'	'NORTHWEST - TATONGA7	345.00 345KV CKT 1'	1195	0.19683	103.8577		'DBL-MEDLO-WI'	
FNSL-Blow 02ALL		0 11G	G08_047			Non Converged	1052	0.26785	86.2944		'FINNEY SWITCHING STATION - STEVENSCO 345.00 345KV CK'	
FNSL-Blow 02ALL		0 11G	G08_047			Non Converged	0	0.2369	9999		'DBL-HIT-G084'	
FNSL-Blow 02ALL		0 11G	G08_047			Non Converged	0	0.2369	9999		'DBL-G0847-WO'	
FDNS 02ALL		0 11G	G08_047	TO->FROM'	'NORTHWEST - TATONGA7	345.00 345KV CKT 1'	1195	0.19683	103.8577		'DBL-MEDLO-WI'	
FNSL-Blow 02G0847		0 11G	G08_047			Non Converged	0	0.60028	9999		'DBL-G0847-WO'	
FNSL-Blow 02G0847		0 11G	G08_047			Non Converged	0	0.60028	9999		'DBL-G0847-WO'	
FDNS 02ALL		0 11G	G08_047	TO->FROM'	'NORTHWEST - TATONGA7	345.00 345KV CKT 1'	1195	0.22213	109.8945		'DBL-MEDLO-WI'	
FDNS 02ALL		0 11G	G08_047	TO->FROM'	'NORTHWEST - TATONGA7	345.00 345KV CKT 1'	1195	0.26734	108.4191		'DBL-WOOD-MED'	
FDNS 02ALL		0 11G	G08_047	TO->FROM'	'FINNEY SWITCHING STATION - STEVENSCO	345.00	1052	0.22005	115.9808		'DBL-WOOD-MED'	
FNSL-Blow 02ALL		0 11G	G08_047			Non Converged	0	0.58408	9999		'DBL-G0847-WO'	
FNSL-Itera 02ALL		2 11G	G08_047			Non Converged	0	0.5433	9999		'DBL-G0847-WO'	
FDNS 02ALL		2 11G	G08_047	TO->FROM'	'NORTHWEST - TATONGA7	345.00 345KV CKT 1'	1195	0.224	112.085		'DBL-MEDLO-WI'	
FDNS 02ALL		2 11G	G08_047	TO->FROM'	'NORTHWEST - TATONGA7	345.00 345KV CKT 1'	1195	0.26999	112.4579		'DBL-WOOD-MED'	
FDNS 02ALL		2 11G	G08_047	TO->FROM'	'FINNEY SWITCHING STATION - STEVENSCO	345.00	1052	0.21498	107.259		'DBL-WOOD-MED'	
FDNS 02ALL		3 11G	G08_047	TO->FROM'	'FINNEY SWITCHING STATION - STEVENSCO	345.00	1052	0.24638	113.9175		'DBL-G0847-WO'	
FNSL-Blow 02G08110		0 11G	G08_047			Non Converged	0	0.59665	9999		'DBL-G0847-WO'	
FDNS 02G08110		0 11G	G08_047	TO->FROM'	'NORTHWEST - TATONGA7	345.00 345KV CKT 1'	1195	0.22874	95.7		'DBL-MEDLO-WI'	
FDNS 02G08110		0 11G	G08_047	TO->FROM'	'NORTHWEST - TATONGA7	345.00 345KV CKT 1'	1195	0.27444	95.1		'DBL-WOOD-MED'	
FDNS 02G08110		0 11G	G08_047	TO->FROM'	'FINNEY SWITCHING STATION - STEVENSCO	345.00	1052	0.22969	96.4		'DBL-WOOD-MED'	
FDNS 02G08110		2 11G	G08_047	TO->FROM'	'NORTHWEST - TATONGA7	345.00 345KV CKT 1'	1195	0.23068	97.3		'DBL-MEDLO-WI'	
FDNS 02G08110		2 11G	G08_047	TO->FROM'	'FINNEY SWITCHING STATION - STEVENSCO	345.00	1052	0.28388	97		'DBL-G0847-WO'	
FDNS 02G08110		2 11G	G08_047	TO->FROM'	'NORTHWEST - TATONGA7	345.00 345KV CKT 1'	1195	0.27728	98		'DBL-WOOD-MED'	
FNSL-Itera 02G0847		0 11G	G08_047			Non Converged	0	0.59496	9999		'DBL-G0847-WO'	
FDNS 02G0847		0 11G	G08_047	TO->FROM'	'NORTHWEST - TATONGA7	345.00 345KV CKT 1'	1195	0.22812	97.4		'DBL-MEDLO-WI'	
FDNS 02G0847		0 11G	G08_047	TO->FROM'	'NORTHWEST - TATONGA7	345.00 345KV CKT 1'	1195	0.27367	97.1		'DBL-WOOD-MED'	
FDNS 02G0847		0 11G	G08_047	TO->FROM'	'FINNEY SWITCHING STATION - STEVENSCO	345.00	1052	0.22929	98		'DBL-WOOD-MED'	
FDNS 02G0847		2 11G	G08_047	TO->FROM'	'NORTHWEST - TATONGA7	345.00 345KV CKT 1'	1195	0.23006	99		'DBL-MEDLO-WI'	
FDNS 02G0847		2 11G	G08_047	TO->FROM'	'NORTHWEST - TATONGA7	345.00 345KV CKT 1'	1195	0.27652	100		'DBL-WOOD-MED'	
FNSL 02G0847		2 11G	G08_047	TO->FROM'	'FINNEY SWITCHING STATION - STEVENSCO	345.00	1052	0.28324	99.7		'DBL-G0847-WO'	
FNSL-Itera 02G1007		0 11G	G08_047			Non Converged	0	0.59747	9999		'DBL-G0847-WO'	
FDNS 02G1007		2 11G	G08_047	TO->FROM'	'NORTHWEST - TATONGA7	345.00 345KV CKT 1'	1195	0.23106	96.4		'DBL-MEDLO-WI'	
FDNS 02G1007		2 11G	G08_047	TO->FROM'	'NORTHWEST - TATONGA7	345.00 345KV CKT 1'	1195	0.2777	96.9		'DBL-WOOD-MED'	
FNSL-Itera 02G1007		2 11G	G08_047			Non Converged	0	0.55379	9999		'DBL-G0847-WO'	
FNSL-Itera 02G1014		0 11G	G08_047			Non Converged	0	0.59642	9999		'DBL-G0847-WO'	
FDNS 02G1014		0 11G	G08_047	TO->FROM'	'NORTHWEST - TATONGA7	345.00 345KV CKT 1'	1195	0.22862	96		'DBL-MEDLO-WI'	
FDNS 02G1014		0 11G	G08_047	TO->FROM'	'NORTHWEST - TATONGA7	345.00 345KV CKT 1'	1195	0.27432	95.4		'DBL-WOOD-MED'	
FDNS 02G1014		0 11G	G08_047	TO->FROM'	'FINNEY SWITCHING STATION - STEVENSCO	345.00	1052	0.22958	96.9		'DBL-WOOD-MED'	
FDNS 02G1014		2 11G	G08_047	TO->FROM'	'NORTHWEST - TATONGA7	345.00 345KV CKT 1'	1195	0.23057	97.6		'DBL-MEDLO-WI'	
FDNS 02G1014		2 11G	G08_047	TO->FROM'	'FINNEY SWITCHING STATION - STEVENSCO	345.00	1052	0.28377	97.6		'DBL-G0847-WO'	
FDNS 02G1014		2 11G	G08_047	TO->FROM'	'NORTHWEST - TATONGA7	345.00 345KV CKT 1'	1195	0.27715	98.3		'DBL-WOOD-MED'	
FNSL-Blow	2	0 11G	G08_047			Non Converged	0	0.59766	9999		'DBL-G0847-WO'	
FDNS	2	2 11G	G08_047	TO->FROM'	'NORTHWEST - TATONGA7	345.00 345KV CKT 1'	1195	0.23117	96.1		'DBL-MEDLO-WI'	
FDNS	2	2 11G	G08_047	TO->FROM'	'NORTHWEST - TATONGA7	345.00 345KV CKT 1'	1195	0.27783	96.5		'DBL-WOOD-MED'	
FNSL-Itera	2	2 11G	G08_047			Non Converged	0	0.55394	9999		'DBL-G0847-WO'	
FNSL-Itera 02ALL		0 11G	G08_047			Non Converged	1052	0.18928	82.65054		'FINNEY SWITCHING STATION - STEVENSCO 345.00 345KV CK'	
FNSL-Itera 02ALL		0 11G	G08_047			Non Converged	0	0.14022	9999		'SPP-SWPS-02'	
FNSL-Itera 02ALL		0 11G	G08_047			Non Converged	1052	0.1219	82.65054		'FINNEY SWITCHING STATION - STEVENSCO 345.00 345KV CK'	
FNSL-Itera 02ALL		0 11G	G08_047			Non Converged	441	0.10557	57.61415		'STATELINE INTERCHANGE - STLN-DEMARC6230.00 230KV CKT	
FNSL-Itera 02ALL		0 11G	G08_047			Non Converged	0	0.08071	9999		'ATC_B2_8E2_G'	
FNSL-Itera 02ALL		0 11G	G08_047			Non Converged	0	0.07831	9999		'050 1'	
FNSL-Itera 02ALL		0 11G	G08_047			Non Converged	0	0.07801	9999		'050 1'	
FNSL-Itera 02ALL		0 11G	G08_047			Non Converged	0	0.07546	9999		'ATC_B2_8E2'	
FNSL-Itera 02ALL		0 11G	G08_047			Non Converged	0	0.07378	9999		'050 2'	
FNSL-Itera 02ALL		0 11G	G08_047			Non Converged	441	0.0701	57.58744		'STATELINE INTERCHANGE - STLN-DEMARC6230.00 230KV CKT	
FNSL-Blow 02ALL		0 11G	G08_047			Non Converged	0	0.05469	9999		'ATC_B2_8E2_G'	
FNSL-Itera 02ALL		0 11G	G08_047			Non Converged	0	0.05248	9999		'SPP-SWPS-03'	
FNSL-Itera 02ALL		0 11G	G08_047			Non Converged	0	0.04963	9999		'050 2'	
FNSL-Itera 02ALL		0 11G	G08_047			Non Converged	441	0.0415	56.34883		'STATELINE INTERCHANGE - STLN-DEMARC6230.00 230KV CKT	

SOLUTION GROUP	SCENARI	SEASON	SOURCE	DIRECTION	MONITORED ELEMENT	COMMON NAME	RATEB	TDF	TC%	LOAD	CONTINGENCY	NAME
FNSL-Itera 02ALL		0 11G	G08_047		Non Converged		1052	0.03153	82.65054	'FINNEY SWITCHING STATION - STEVENSCO	345.00	345KV CKT
FNSL-Itera 02ALL		0 11G	G08_047		Non Converged		0	0.02998	9999	'050 1'		
FNSL-Itera 02ALL		0 11G	G08_047		Non Converged		0	0.02791	9999	'050 2'		
FNSL-Itera 02ALL		0 11G	G08_047		Non Converged		0	0.02538	9999	'SPP-SWPS-03'		
FNSL-Itera 02ALL		0 11G	G08_047		Non Converged		0	0.02261	9999	'050 1'		
FNSL-Itera 02ALL		0 11G	G08_047		Non Converged		441	0.02203	56.82947	'STLN-DEMARC6230.00 - SWEETWT6	230.00	230KV CKT 1'
FNSL-Blow 02ALL		0 11G	G08_047		Non Converged		1052	0.13545	97.33807	'FINNEY SWITCHING STATION - STEVENSCO	345.00	345KV CKT
FNSL-Blow 02ALL		0 11G	G08_047		Non Converged		0	0.58408	9999	'DBL-G0847-WO'		
FNSL-Itera 02ALL		2 11G	G08_047		Non Converged		1052	0.12459	82.65054	'FINNEY SWITCHING STATION - STEVENSCO	345.00	345KV CKT
FNSL-Itera 02ALL		2 11G	G08_047		Non Converged		0	0.5433	9999	'DBL-G0847-WO'		
FNSL-Blow 02G08110		0 11G	G08_047		Non Converged		0	0.59665	9999	'DBL-G0847-WO'		
FNSL-Itera 02G08110		0 11G	G08_047		Non Converged		0	0.04406	9999	'SPP-SWPS-02'		
FNSL-Itera 02G0847		0 11G	G08_047		Non Converged		0	0.59496	9999	'DBL-G0847-WO'		
FNSL-Itera 02G0847		0 11G	G08_047		Non Converged		0	0.044	9999	'SPP-SWPS-02'		
FNSL-Itera 02G0847		0 11G	G08_047		Non Converged		1195	0.04133	39.00984	'LAWTON EASTSIDE - OKLAUNION 345KV CKT 1'		
FNSL-Blow 02G0847		0 11G	G08_047		Non Converged		0	0.60028	9999	'DBL-G0847-WO'		
FNSL-Itera 02G0847		2 11G	G08_047		Non Converged		1195	0.04522	41.32254	'LAWTON EASTSIDE - OKLAUNION 345KV CKT 1'		
FNSL-Itera 02G1007		0 11G	G08_047		Non Converged		1052	0.14352	77.23053	'FINNEY SWITCHING STATION - STEVENSCO	345.00	345KV CKT
FNSL-Itera 02G1007		0 11G	G08_047		Non Converged		0	0.59747	9999	'DBL-G0847-WO'		
FNSL-Itera 02G1007		0 11G	G08_047		Non Converged		0	0.0441	9999	'SPP-SWPS-02'		
FNSL-Itera 02G1007		2 11G	G08_047		Non Converged		0	0.55379	9999	'DBL-G0847-WO'		
FNSL-Itera 02G1014		0 11G	G08_047		Non Converged		0	0.59642	9999	'DBL-G0847-WO'		
FNSL-Itera 02G1014		0 11G	G08_047		Non Converged		0	0.04398	9999	'SPP-SWPS-02'		
FNSL-Itera	2	0 11G	G08_047		Non Converged		1052	0.14363	76.82405	'FINNEY SWITCHING STATION - STEVENSCO	345.00	345KV CKT
FNSL-Blow	2	0 11G	G08_047		Non Converged		0	0.59766	9999	'DBL-G0847-WO'		
FNSL-Itera	2	0 11G	G08_047		Non Converged		0	0.04423	9999	'SPP-SWPS-02'		
FNSL-Itera	2	2 11G	G08_047		Non Converged		0	0.55394	9999	'DBL-G0847-WO'		
FNSL-Blow 03ALL		0 11G	G08_047		Non Converged		0	0.18388	9999	'DBL-MEDLO-WI'		
FNSL-Itera	6	0 11G	G08_047		Non Converged		0	0.04674	9999	'SPP-SWPS-03'		
FNSL-Itera 02ALL		0 11G	G08_071		Non Converged		0	0.15031	9999	'DBL-G0847-WO'		
FNSL-Itera 02ALL		0 11G	G08_071		Non Converged		0	0.12691	9999	'SPP-SWPS-03'		
FNSL-Itera 02ALL		0 11G	G08_071		Non Converged		441	0.11741	57.61415	'STATELINE INTERCHANGE - STLN-DEMARC6230.00 230KV CKT		
FNSL-Itera 02ALL		0 11G	G08_071		Non Converged		0	0.08283	9999	'SPP-SWPS-02'		
FNSL-Itera 02ALL		0 11G	G08_071		Non Converged		0	0.08061	9999	'ATC_B2_8E2_G'		
FNSL-Itera 02ALL		0 11G	G08_071		Non Converged		0	0.07821	9999	'050 1'		
FNSL-Itera 02ALL		0 11G	G08_071		Non Converged		0	0.0755	9999	'ATC_B2_8E2'		
FNSL-Itera 02ALL		0 11G	G08_071		Non Converged		0	0.07387	9999	'050 2'		
FNSL-Itera 02ALL		0 11G	G08_071		Non Converged		441	0.07146	56.87944	'STATELINE INTERCHANGE - STLN-DEMARC6230.00 230KV CKT		
FNSL-Itera 02ALL		0 11G	G08_071		Non Converged		441	0.06332	57.58744	'STATELINE INTERCHANGE - STLN-DEMARC6230.00 230KV CKT		
FNSL-Blow 02ALL		0 11G	G08_071		Non Converged		0	0.0529	9999	'050 1'		
FNSL-Itera 02ALL		0 11G	G08_071		Non Converged		0	0.05104	9999	'ATC_B2_8E2'		
FNSL-Itera 02ALL		0 11G	G08_071		Non Converged		0	0.0441	9999	'SPP-SWPS-02'		
FNSL-Itera 02ALL		0 11G	G08_071		Non Converged		441	0.04139	57.29366	'STLN-DEMARC6230.00 - SWEETWT6	230.00	230KV CKT 1'
FNSL-Itera 02ALL		0 11G	G08_071		Non Converged		0	0.03121	9999	'ATC_B2_8E2_G'		
FNSL-Itera 02ALL		0 11G	G08_071		Non Converged		0	0.02896	9999	'ATC_B2_8E2'		
FNSL-Itera 02ALL		0 11G	G08_071		Non Converged		0	0.02725	9999	'TRF-STEGALL'		
FNSL-Itera 02ALL		0 11G	G08_071		Non Converged		1052	0.0232	82.65054	'FINNEY SWITCHING STATION - STEVENSCO	345.00	345KV CKT
FNSL-Itera 02ALL		0 11G	G08_071		Non Converged		0	0.02214	9999	'ATC_B2_8E2_G'		
FNSL-Itera 02ALL		0 11G	G08_071		Non Converged		0	0.02183	9999	'ATC_B2_8E2'		
FDNS	2	0 11G	G08_088	'TO->FROM'	'FINNEY SWITCHING STATION - STEVENSCO	345.00	1052	0.30486	111.9602	'DBL-HIT-G084'		
FNSL-Itera	2	0 11G	G08_088		Non Converged		0	0.24376	9999	'DBL-G0847-WO'		
FDNS	2	0 11G	G08_088	'TO->FROM'	'FINNEY SWITCHING STATION - STEVENSCO	345.00	1052	0.30486	111.9602	'DBL-HIT-G084'		
FNSL-Itera	2	0 11G	G08_088		Non Converged		0	0.24376	9999	'DBL-G0847-WO'		
FDNS	5	0 11G	G08_088	'TO->FROM'	'SWITCH 2749 - WILDORADO 69KV CKT 1'		35	0.99854	104.3714	'BASE CASE'		
FDNS	5	0 11G	G08_088	'TO->FROM'	'SWITCH 2749 - WILDORADO 69KV CKT 1'		35	0.99854	104.3714	'BASE CASE'		
FNSL-Itera	6	0 11G	G08_088		Non Converged		0	0.21936	9999	'SPP-SWPS-03'		
FNSL-Itera	6	0 11G	G08_088		Non Converged		0	0.21936	9999	'SPP-SWPS-03'		
FNSL-Blow 02ALL		0 11G	G08_088		Non Converged		1052	0.19729	86.2944	'FINNEY SWITCHING STATION - STEVENSCO	345.00	345KV CKT
FNSL-Blow 02ALL		0 11G	G08_088		Non Converged		1052	0.19729	86.2944	'FINNEY SWITCHING STATION - STEVENSCO	345.00	345KV CKT
FDNS	00G08_08	0 11SP	G08_088	'TO->FROM'	'SWITCH 2749 - WILDORADO 69KV CKT 1'		35	0.99867	125.211	'BASE CASE'		
FDNS	00G08_08	0 11WP	G08_088	'TO->FROM'	'SWITCH 2749 - WILDORADO 69KV CKT 1'		35	0.99818	130.7829	'BASE CASE'		
FDNS	00G08_08	0 16SP	G08_088	'TO->FROM'	'SWITCH 2749 - WILDORADO 69KV CKT 1'		35	0.99877	121.8648	'BASE CASE'		
FDNS	00G08_08	0 16WP	G08_088	'TO->FROM'	'SWITCH 2749 - WILDORADO 69KV CKT 1'		35	0.99834	128.1723	'BASE CASE'		
FDNS	00G08_08	0 11SP	G08_088	'TO->FROM'	'SWITCH 2749 - WILDORADO 69KV CKT 1'		35	0.99867	125.211	'BASE CASE'		
FDNS	00G08_08	0 11WP	G08_088	'TO->FROM'	'SWITCH 2749 - WILDORADO 69KV CKT 1'		35	0.99818	130.7829	'BASE CASE'		
FDNS	00G08_08	0 16SP	G08_088	'TO->FROM'	'SWITCH 2749 - WILDORADO 69KV CKT 1'		35	0.99877	121.8648	'BASE CASE'		
FDNS	00G08_08	0 16WP	G08_088	'TO->FROM'	'SWITCH 2749 - WILDORADO 69KV CKT 1'		35	0.99834	128.1723	'BASE CASE'		

SOLUTION GROUP	SCENARIK	SEASON	SOURCE	DIRECTION	MONITORED ELEMENT	COMMON NAME	RATEB	TDF	TC%	LOAD	CONTINGENCY	NAME
FDNS	05G0888	0 11G	G08_088	'TO->FROM'	'SWITCH 2749 - WILDORADO 69KV CKT 1'		35	0.99818	132.5093			'BASE CASE'
FNSL-Itera	05G0888	0 11G	G08_088		Non Converged		0	0.23369	9999			'SPP-SWPS-02'
FDNS	05G0888	0 11G	G08_088	'TO->FROM'	'SWITCH 2749 - WILDORADO 69KV CKT 1'		35	0.99818	132.5093			'BASE CASE'
FNSL-Itera	05G0888	0 11G	G08_088		Non Converged		0	0.23369	9999			'SPP-SWPS-02'
FDNS	02ALL	0 11G	G08_088	'TO->FROM'	'FINNEY SWITCHING STATION - STEVENSCO	345.00	1052	0.20651	115.9808			'DBL-WOOD-MED'
FNSL-Blow	02ALL	0 11G	G08_088		Non Converged		0	0.24778	9999			'DBL-HIT-G084'
FNSL-Blow	02ALL	0 11G	G08_088		Non Converged		0	0.22622	9999			'DBL-G0847-WO'
FNSL-Itera	02ALL	2 11G	G08_088		Non Converged		0	0.19159	9999			'DBL-G0847-WO'
FDNS	02ALL	2 11G	G08_088	'TO->FROM'	'FINNEY SWITCHING STATION - STEVENSCO	345.00	1052	0.19997	99.5			'DBL-HIT-G084'
FDNS	02ALL	2 11G	G08_088	'TO->FROM'	'FINNEY SWITCHING STATION - STEVENSCO	345.00	1052	0.20157	107.259			'DBL-WOOD-MED'
FNSL-Blow	02G08110	0 11G	G08_088		Non Converged		0	0.23879	9999			'DBL-G0847-WO'
FNSL-Itera	02G08110	0 11G	G08_088		Non Converged		0	0.23487	9999			'SPP-SWPS-02'
FDNS	02G08110	0 11G	G08_088	'TO->FROM'	'FINNEY SWITCHING STATION - STEVENSCO	345.00	1052	0.29825	132.1299			'DBL-HIT-G084'
FDNS	02G08110	0 11G	G08_088	'TO->FROM'	'FINNEY SWITCHING STATION - STEVENSCO	345.00	1052	0.21615	96.4			'DBL-WOOD-MED'
FDNS	02G08110	2 11G	G08_088	'TO->FROM'	'FINNEY SWITCHING STATION - STEVENSCO	345.00	1052	0.20366	97			'DBL-G0847-WO'
FNSL-Itera	02G08110	3 11G	G08_088		Non Converged		0	0.20098	9999			'SPP-SWPS-03'
FNSL-Itera	02G0847	0 11G	G08_088		Non Converged		0	0.2371	9999			'DBL-G0847-WO'
FNSL-Itera	02G0847	0 11G	G08_088		Non Converged		0	0.23481	9999			'SPP-SWPS-02'
FDNS	02G0847	0 11G	G08_088	'TO->FROM'	'FINNEY SWITCHING STATION - STEVENSCO	345.00	1052	0.29948	128.0221			'DBL-HIT-G084'
FDNS	02G0847	0 11G	G08_088	'TO->FROM'	'FINNEY SWITCHING STATION - STEVENSCO	345.00	1052	0.21575	98			'DBL-WOOD-MED'
FNSL	02G0847	2 11G	G08_088	'TO->FROM'	'FINNEY SWITCHING STATION - STEVENSCO	345.00	1052	0.20303	99.7			'DBL-G0847-WO'
FNSL-Itera	02G0847	3 11G	G08_088		Non Converged		0	0.20095	9999			'SPP-SWPS-03'
FDNS	02G1007	0 11G	G08_088	'TO->FROM'	'FINNEY SWITCHING STATION - STEVENSCO	345.00	1052	0.29915	128.8406			'DBL-HIT-G084'
FNSL-Itera	02G1007	0 11G	G08_088		Non Converged		0	0.23961	9999			'DBL-G0847-WO'
FNSL-Itera	02G1007	0 11G	G08_088		Non Converged		0	0.23491	9999			'SPP-SWPS-02'
FNSL-Itera	02G1007	2 11G	G08_088		Non Converged		0	0.20208	9999			'DBL-G0847-WO'
FNSL-Itera	02G1007	3 11G	G08_088		Non Converged		0	0.20099	9999			'SPP-SWPS-03'
FNSL-Itera	02G1014	0 11G	G08_088		Non Converged		0	0.23856	9999			'DBL-G0847-WO'
FNSL-Itera	02G1014	0 11G	G08_088		Non Converged		0	0.23478	9999			'SPP-SWPS-02'
FDNS	02G1014	0 11G	G08_088	'TO->FROM'	'FINNEY SWITCHING STATION - STEVENSCO	345.00	1052	0.29804	133.3729			'DBL-HIT-G084'
FDNS	02G1014	0 11G	G08_088	'TO->FROM'	'FINNEY SWITCHING STATION - STEVENSCO	345.00	1052	0.21605	96.9			'DBL-WOOD-MED'
FDNS	02G1014	2 11G	G08_088	'TO->FROM'	'FINNEY SWITCHING STATION - STEVENSCO	345.00	1052	0.20356	97.6			'DBL-G0847-WO'
FNSL-Itera	02G1014	3 11G	G08_088		Non Converged		0	0.20093	9999			'SPP-SWPS-03'
FDNS	2	0 11G	G08_088	'TO->FROM'	'FINNEY SWITCHING STATION - STEVENSCO	345.00	1052	0.29937	128.0433			'DBL-HIT-G084'
FNSL-Blow	2	0 11G	G08_088		Non Converged		0	0.2398	9999			'DBL-G0847-WO'
FNSL-Itera	2	0 11G	G08_088		Non Converged		0	0.23504	9999			'SPP-SWPS-02'
FNSL-Itera	2	2 11G	G08_088		Non Converged		0	0.20223	9999			'DBL-G0847-WO'
FNSL-Itera	2	3 11G	G08_088		Non Converged		0	0.20109	9999			'SPP-SWPS-03'
FNSL-Itera	02ALL	0 11G	G08_088		Non Converged		1052	0.1678	97.33807			'FINNEY SWITCHING STATION - STEVENSCO 345.00 345KV CKT'
FNSL-Itera	02ALL	0 11G	G08_088		Non Converged		0	0.12916	9999			'SPP-SWPS-03'
FNSL-Itera	02ALL	0 11G	G08_088		Non Converged		441	0.11752	56.03129			'STLN-DEMARC6230.00 - SWEETWT6 230.00 230KV CKT 1'
FNSL-Itera	02ALL	0 11G	G08_088		Non Converged		0	0.09474	9999			'SPP-SWPS-03'
FNSL-Itera	02ALL	0 11G	G08_088		Non Converged		0	0.08063	9999			'ATC_B2_8E2_G'
FNSL-Itera	02ALL	0 11G	G08_088		Non Converged		0	0.07823	9999			'050 1'
FNSL-Itera	02ALL	0 11G	G08_088		Non Converged		0	0.07557	9999			'ATC_B2_8E2'
FNSL-Itera	02ALL	0 11G	G08_088		Non Converged		0	0.07389	9999			'050 2'
FNSL-Itera	02ALL	0 11G	G08_088		Non Converged		0	0.07365	9999			'050 2'
FNSL-Itera	02ALL	0 11G	G08_088		Non Converged		441	0.06339	56.87944			'STATELINE INTERCHANGE - STLN-DEMARC6230.00 230KV CKT'
FNSL-Blow	02ALL	0 11G	G08_088		Non Converged		0	0.05292	9999			'050 1'
FNSL-Itera	02ALL	0 11G	G08_088		Non Converged		0	0.05105	9999			'ATC_B2_8E2'
FNSL-Itera	02ALL	0 11G	G08_088		Non Converged		0	0.04949	9999			'050 2'
FNSL-Itera	02ALL	0 11G	G08_088		Non Converged		441	0.04142	56.82947			'STLN-DEMARC6230.00 - SWEETWT6 230.00 230KV CKT 1'
FNSL-Itera	02ALL	0 11G	G08_088		Non Converged		0	0.03141	9999			'ATC_B2_8E2_G'
FNSL-Itera	02ALL	0 11G	G08_088		Non Converged		0	0.02905	9999			'ATC_B2_8E2'
FNSL-Itera	02ALL	0 11G	G08_088		Non Converged		0	0.0278	9999			'050 2'
FNSL-Itera	02ALL	0 11G	G08_088		Non Converged		0	0.02346	9999			'ATC_B2_8E2_G'
FNSL-Itera	02ALL	0 11G	G08_088		Non Converged		0	0.02234	9999			'050 1'
FNSL-Itera	02ALL	0 11G	G08_088		Non Converged		441	0.02199	57.58744			'STATELINE INTERCHANGE - STLN-DEMARC6230.00 230KV CKT'
FNSL-Blow	02ALL	0 11G	G08_088		Non Converged		1052	0.15047	97.33807			'FINNEY SWITCHING STATION - STEVENSCO 345.00 345KV CKT'
FNSL-Blow	02ALL	0 11G	G08_088		Non Converged		0	0.24778	9999			'DBL-HIT-G084'
FNSL-Blow	02ALL	0 11G	G08_088		Non Converged		0	0.22622	9999			'DBL-G0847-WO'
FNSL-Itera	02ALL	0 11G	G08_088		Non Converged		0	0.10657	9999			'SPP-SWPS-T53'
FNSL-Itera	02ALL	2 11G	G08_088		Non Converged		1052	0.14125	82.65054			'FINNEY SWITCHING STATION - STEVENSCO 345.00 345KV CKT'
FNSL-Itera	02ALL	2 11G	G08_088		Non Converged		0	0.19159	9999			'DBL-G0847-WO'
FNSL-Blow	02G08110	0 11G	G08_088		Non Converged		0	0.23879	9999			'DBL-G0847-WO'
FNSL-Itera	02G08110	0 11G	G08_088		Non Converged		0	0.23487	9999			'SPP-SWPS-02'
FNSL-Itera	02G08110	0 11G	G08_088		Non Converged		441	0.11744	56.82947			'STLN-DEMARC6230.00 - SWEETWT6 230.00 230KV CKT 1'

SOLUTION GROUP	SCENARI SEASON	SOURCE	DIRECTION	MONITORED ELEMENT	COMMON NAME	RATEB	TDF	TC%	LOAD	CONTINGENCY	NAME
FNSL-Itera 02G08110	0 11G	G08_088		Non Converged		441	0.11744	57.15012	'STATELINE INTERCHANGE - STLN-DEMAR	6230.00	230KV CKT
FNSL-Itera 02G08110	3 11G	G08_088		Non Converged		0	0.20098	9999	'SPP-SWPS-03'		
FNSL-Itera 02G0847	0 11G	G08_088		Non Converged		441	0.11741	57.61415	'STATELINE INTERCHANGE - STLN-DEMAR	6230.00	230KV CKT
FNSL-Itera 02G0847	0 11G	G08_088		Non Converged		0	0.2371	9999	'DBL-G0847-WO'		
FNSL-Itera 02G0847	0 11G	G08_088		Non Converged		0	0.23481	9999	'SPP-SWPS-02'		
FNSL-Itera 02G0847	0 11G	G08_088		Non Converged		441	0.11741	57.29366	'STLN-DEMAR	6230.00	SWEETWT6 230.00 230KV CKT 1'
FNSL-Itera 02G0847	0 11G	G08_088		Non Converged		351	0.09753	82.03278	'GRAPEVINE INTERCHANGE - NICHOLS STATION	230KV CKT 1'	
FNSL-Itera 02G0847	3 11G	G08_088		Non Converged		0	0.20095	9999	'SPP-SWPS-03'		
FNSL-Itera 02G1007	0 11G	G08_088		Non Converged		441	0.11746	56.55862	'STLN-DEMAR	6230.00	SWEETWT6 230.00 230KV CKT 1'
FNSL-Itera 02G1007	0 11G	G08_088		Non Converged		441	0.11746	56.87944	'STATELINE INTERCHANGE - STLN-DEMAR	6230.00	230KV CKT
FNSL-Itera 02G1007	0 11G	G08_088		Non Converged		1052	0.15854	77.23053	'FINNEY SWITCHING STATION - STEVENSCO	345.00	345KV CKT
FNSL-Itera 02G1007	0 11G	G08_088		Non Converged		0	0.23961	9999	'DBL-G0847-WO'		
FNSL-Itera 02G1007	0 11G	G08_088		Non Converged		0	0.23491	9999	'SPP-SWPS-02'		
FNSL-Itera 02G1007	2 11G	G08_088		Non Converged		0	0.20208	9999	'DBL-G0847-WO'		
FNSL-Itera 02G1007	3 11G	G08_088		Non Converged		0	0.20099	9999	'SPP-SWPS-03'		
FNSL-Itera 02G1014	0 11G	G08_088		Non Converged		0	0.23856	9999	'DBL-G0847-WO'		
FNSL-Itera 02G1014	0 11G	G08_088		Non Converged		0	0.23478	9999	'SPP-SWPS-02'		
FNSL-Itera 02G1014	0 11G	G08_088		Non Converged		441	0.11739	57.2667	'STLN-DEMAR	6230.00	SWEETWT6 230.00 230KV CKT 1'
FNSL-Itera 02G1014	0 11G	G08_088		Non Converged		351	0.09752	81.98898	'GRAPEVINE INTERCHANGE - NICHOLS STATION	230KV CKT 1'	
FNSL-Itera 02G1014	0 11G	G08_088		Non Converged		441	0.11739	57.58744	'STATELINE INTERCHANGE - STLN-DEMAR	6230.00	230KV CKT
FNSL-Itera 02G1014	3 11G	G08_088		Non Converged		0	0.20093	9999	'SPP-SWPS-03'		
FNSL-Itera 2	0 11G	G08_088		Non Converged		441	0.11752	56.03129	'STLN-DEMAR	6230.00	SWEETWT6 230.00 230KV CKT 1'
FNSL-Itera 2	0 11G	G08_088		Non Converged		441	0.11752	56.34883	'STATELINE INTERCHANGE - STLN-DEMAR	6230.00	230KV CKT
FNSL-Itera 2	0 11G	G08_088		Non Converged		1052	0.15866	76.82405	'FINNEY SWITCHING STATION - STEVENSCO	345.00	345KV CKT
FNSL-Blow 2	0 11G	G08_088		Non Converged		0	0.2398	9999	'DBL-G0847-WO'		
FNSL-Itera 2	0 11G	G08_088		Non Converged		0	0.23504	9999	'SPP-SWPS-02'		
FNSL-Itera 2	2 11G	G08_088		Non Converged		0	0.20223	9999	'DBL-G0847-WO'		
FNSL-Itera 2	3 11G	G08_088		Non Converged		0	0.20109	9999	'SPP-SWPS-03'		
FNSL-Blow 03ALL	0 11G	G08_088		Non Converged		0	0.14238	9999	'DBL-MEDLO-WI'		
FNSL-Itera 05G0888	0 11G	G08_088		Non Converged		441	0.11684	58.05816	'STATELINE INTERCHANGE - STLN-DEMAR	6230.00	230KV CKT
FNSL-Itera 05G0888	0 11G	G08_088		Non Converged		0	0.23369	9999	'SPP-SWPS-02'		
FNSL-Itera 6	0 11G	G08_088		Non Converged		0	0.21936	9999	'SPP-SWPS-03'		
FNSL-Itera 02ALL	0 11G	G08_098		Non Converged		0	0.14279	9999	'SPP-SWPS-02'		
FNSL-Itera 02ALL	0 11G	G08_098		Non Converged		0	0.12401	9999	'DBL-G0847-WO'		
FNSL-Itera 02ALL	0 11G	G08_098		Non Converged		441	0.10569	56.34883	'STATELINE INTERCHANGE - STLN-DEMAR	6230.00	230KV CKT
FNSL-Itera 02ALL	0 11G	G08_098		Non Converged		0	0.08073	9999	'ATC_B2_8E2_G'		
FNSL-Itera 02ALL	0 11G	G08_098		Non Converged		0	0.08042	9999	'ATC_B2_8E2_G'		
FNSL-Itera 02ALL	0 11G	G08_098		Non Converged		0	0.07818	9999	'050 1'		
FNSL-Itera 02ALL	0 11G	G08_098		Non Converged		0	0.07547	9999	'ATC_B2_8E2'		
FNSL-Itera 02ALL	0 11G	G08_098		Non Converged		0	0.07379	9999	'050 2'		
FNSL-Itera 02ALL	0 11G	G08_098		Non Converged		441	0.07014	56.82947	'STLN-DEMAR	6230.00	SWEETWT6 230.00 230KV CKT 1'
FNSL-Itera 02ALL	0 11G	G08_098		Non Converged		0	0.05481	9999	'ATC_B2_8E2_G'		
FNSL-Blow 02ALL	0 11G	G08_098		Non Converged		0	0.0526	9999	'SPP-SWPS-03'		
FNSL-Itera 02ALL	0 11G	G08_098		Non Converged		0	0.04965	9999	'050 2'		
FNSL-Itera 02ALL	0 11G	G08_098		Non Converged		1052	0.04219	76.82405	'FINNEY SWITCHING STATION - STEVENSCO	345.00	345KV CKT
FNSL-Itera 02ALL	0 11G	G08_098		Non Converged		0	0.03263	9999	'TRF-STEGALL'		
FNSL-Itera 02ALL	0 11G	G08_098		Non Converged		0	0.03002	9999	'050 1'		
FNSL-Itera 02ALL	0 11G	G08_098		Non Converged		0	0.02873	9999	'ATC_B2_8E2'		
FNSL-Itera 02ALL	0 11G	G08_098		Non Converged		0	0.02545	9999	'SPP-SWPS-03'		
FNSL-Itera 02ALL	0 11G	G08_098		Non Converged		0	0.02263	9999	'050 1'		
FNSL-Itera 02ALL	0 11G	G08_098		Non Converged		441	0.02205	56.55862	'STLN-DEMAR	6230.00	SWEETWT6 230.00 230KV CKT 1'
FNSL-Itera 02ALL	0 11G	G08_098		Non Converged		0	0.02172	9999	'ATC_B2_8E2_G'		
FDNS 1	0 11G	G08_110	'TO->FROM'	'NORTHWEST - TATONGA7	345.00 345KV CKT 1'	1195	0.19063	104.2029	'DBL-MEDLO-WI'		
FDNS 1	0 11G	G08_110	'TO->FROM'	'NORTHWEST - TATONGA7	345.00 345KV CKT 1'	1195	0.19063	104.2029	'DBL-MEDLO-WI'		
FDNS 2	0 11G	G08_110	'TO->FROM'	'FINNEY SWITCHING STATION - STEVENSCO	345.00	1052	0.48599	111.9602	'DBL-HIT-G084'		
FNSL-Itera 2	0 11G	G08_110		Non Converged		0	0.44548	9999	'DBL-G0847-WO'		
FDNS 2	0 11G	G08_110	'TO->FROM'	'FINNEY SWITCHING STATION - STEVENSCO	345.00	1052	0.48599	111.9602	'DBL-HIT-G084'		
FNSL-Itera 2	0 11G	G08_110		Non Converged		0	0.44548	9999	'DBL-G0847-WO'		
FNSL-Blow 02ALL	0 11G	G08_110		Non Converged		1052	0.26785	86.2944	'FINNEY SWITCHING STATION - STEVENSCO	345.00	345KV CKT
FNSL-Blow 02ALL	0 11G	G08_110		Non Converged		0	0.2369	9999	'DBL-HIT-G084'		
FNSL-Blow 02ALL	0 11G	G08_110		Non Converged		0	0.2369	9999	'DBL-G0847-WO'		
FDNS 02ALL	0 11G	G08_110	'TO->FROM'	'NORTHWEST - TATONGA7	345.00 345KV CKT 1'	1195	0.19683	103.8577	'DBL-MEDLO-WI'		
FNSL-Blow 02ALL	0 11G	G08_110		Non Converged		1052	0.26785	86.2944	'FINNEY SWITCHING STATION - STEVENSCO	345.00	345KV CKT
FNSL-Blow 02ALL	0 11G	G08_110		Non Converged		0	0.2369	9999	'DBL-HIT-G084'		
FNSL-Blow 02ALL	0 11G	G08_110		Non Converged		0	0.2369	9999	'DBL-G0847-WO'		
FDNS 02ALL	0 11G	G08_110	'TO->FROM'	'NORTHWEST - TATONGA7	345.00 345KV CKT 1'	1195	0.19683	103.8577	'DBL-MEDLO-WI'		
FNSL-Itera 02G08110	0 11G	G08_110		Non Converged		0	0.44446	9999	'DBL-G0847-WO'		

SOLUTION GROUP	SCENARIO	SEASON	SOURCE	DIRECTION	MONITORED ELEMENT	COMMON NAME	RATEB	TDF	TC%	LOAD CONTINGENCY	NAME
FDNS	02G08110	0 11G	G08_110	TO->FROM'	'FINNEY SWITCHING STATION - STEVENSCO	345.00	1052	0.48486	115.5341	'DBL-HIT-G084'	
FNSL-Itera	02G08110	0 11G	G08_110		Non Converged		0	0.44446	9999	'DBL-G0847-WO'	
FDNS	02G08110	0 11G	G08_110	TO->FROM'	'FINNEY SWITCHING STATION - STEVENSCO	345.00	1052	0.48486	115.5341	'DBL-HIT-G084'	
FDNS	02ALL	0 11G	G08_110	TO->FROM'	'FINNEY SWITCHING STATION - STEVENSCO	345.00	1052	0.22103	97.3	'BASE CASE'	
FDNS	02ALL	0 11G	G08_110	TO->FROM'	'FINNEY SWITCHING STATION - STEVENSCO	345.00	1052	0.22905	100.4567	'LAWTON EASTSIDE - OKLAUNION 345KV CKT 1'	
FDNS	02ALL	0 11G	G08_110	TO->FROM'	'FINNEY SWITCHING STATION - STEVENSCO	345.00	1052	0.22905	95	'G05-15T 345.00 - OKLAUNION 345KV CKT 1'	
FDNS	02ALL	0 11G	G08_110	TO->FROM'	'NORTHWEST - TATONGA7 345.00 345KV CKT 1'	345.00	1195	0.20943	108.4191	'DBL-WOOD-MED'	
FDNS	02ALL	0 11G	G08_110	TO->FROM'	'FINNEY SWITCHING STATION - STEVENSCO	345.00	1052	0.28162	115.9808	'DBL-WOOD-MED'	
FDNS	02ALL	0 11G	G08_110	TO->FROM'	'FINNEY SWITCHING STATION - STEVENSCO	345.00	1052	0.22783	95.4	'SPP-SWPS-03'	
FDNS	02ALL	0 11G	G08_110	TO->FROM'	'FINNEY SWITCHING STATION - STEVENSCO	345.00	1052	0.22103	98.1	'GEN531447 1-HOLCOMB GENERATOR'	
FNSL-Blow	02ALL	0 11G	G08_110		Non Converged		1052	0.22103	97.33807	'FINNEY SWITCHING STATION - STEVENSCO 345.00 345KV CKT 1'	
FNSL-Blow	02ALL	0 11G	G08_110		Non Converged		0	0.44949	9999	'DBL-HIT-G084'	
FNSL-Blow	02ALL	0 11G	G08_110		Non Converged		0	0.42793	9999	'DBL-G0847-WO'	
FDNS	02ALL	0 11G	G08_110	TO->FROM'	'FINNEY SWITCHING STATION - STEVENSCO	345.00	1052	0.22715	96.7	'ELK CITY 230KV - SWEETWT6 230.00 230KV CKT 1'	
FDNS	02ALL	0 11G	G08_110	TO->FROM'	'FINNEY SWITCHING STATION - STEVENSCO	345.00	1052	0.23624	98.6	'NORTHWEST - TATONGA7 345.00 345KV CKT 1'	
FDNS	02ALL	0 11G	G08_110	TO->FROM'	'FINNEY SWITCHING STATION - STEVENSCO	345.00	1052	0.23703	96.7	'TATONGA7 345.00 - WWRDEHV7 345.00 345KV CKT 1'	
FDNS	02ALL	0 11G	G08_110	TO->FROM'	'FINNEY SWITCHING STATION - STEVENSCO	345.00	1052	0.25271	105.5006	'2008-047 TAP345.00 - WWRDEHV7 345.00 345KV CKT 1'	
FDNS	02ALL	0 11G	G08_110	TO->FROM'	'FINNEY SWITCHING STATION - STEVENSCO	345.00	1052	0.25271	105.5006	'2008-047 TAP345.00 - WWRDEHV7 345.00 345KV CKT 2'	
FDNS	02ALL	0 11G	G08_110	TO->FROM'	'FINNEY SWITCHING STATION - STEVENSCO	345.00	1052	0.23671	95.7	'MED-LDG5 345.00 - WWRDEHV7 345.00 345KV CKT 1'	
FDNS	02ALL	0 11G	G08_110	TO->FROM'	'FINNEY SWITCHING STATION - STEVENSCO	345.00	1052	0.23671	95.7	'MED-LDG5 345.00 - WWRDEHV7 345.00 345KV CKT 2'	
FDNS	02ALL	0 11G	G08_110	TO->FROM'	'FINNEY SWITCHING STATION - STEVENSCO	345.00	1052	0.25431	99	'2008-047 TAP345.00 - Hitchland Interchange 345KV CKT 1'	
FDNS	02ALL	0 11G	G08_110	TO->FROM'	'FINNEY SWITCHING STATION - STEVENSCO	345.00	1052	0.25431	99	'2008-047 TAP345.00 - Hitchland Interchange 345KV CKT 2'	
FDNS	02ALL	0 11G	G08_110	FROM->TO'	'FINNEY SWITCHING STATION - HOLCOMB 345KV CKT 1'	345.00	1052	0.21788	95.1	'FINNEY SWITCHING STATION - HOLCOMB 345KV CKT 1'	
FDNS	02ALL	0 11G	G08_110	FROM->TO'	'FINNEY SWITCHING STATION - HOLCOMB 345KV CKT 2'	345.00	1052	0.21788	95.1	'FINNEY SWITCHING STATION - HOLCOMB 345KV CKT 2'	
FDNS	02ALL	0 11G	G08_110	TO->FROM'	'FINNEY SWITCHING STATION - STEVENSCO	345.00	1052	0.22715	96.7	'ELK CITY 230KV (ELKCTY-6) 230/138/13.8KV TRANSFORMER CK	
FNSL-Itera	02ALL	2 11G	G08_110		Non Converged		0	0.30841	9999	'DBL-G0847-WO'	
FDNS	02ALL	2 11G	G08_110	TO->FROM'	'NORTHWEST - TATONGA7 345.00 345KV CKT 1'	345.00	1195	0.19247	112.085	'DBL-MEDLO-WI'	
FDNS	02ALL	2 11G	G08_110	TO->FROM'	'FINNEY SWITCHING STATION - STEVENSCO	345.00	1052	0.28018	99.5	'DBL-HIT-G084'	
FDNS	02ALL	2 11G	G08_110	TO->FROM'	'NORTHWEST - TATONGA7 345.00 345KV CKT 1'	345.00	1195	0.22052	112.4579	'DBL-WOOD-MED'	
FDNS	02ALL	2 11G	G08_110	TO->FROM'	'FINNEY SWITCHING STATION - STEVENSCO	345.00	1052	0.25918	107.259	'DBL-WOOD-MED'	
FDNS	02ALL	3 11G	G08_110	TO->FROM'	'FINNEY SWITCHING STATION - STEVENSCO	345.00	1052	0.24638	113.9175	'DBL-G0847-WO'	
FNSL-Blow	02G08110	0 11G	G08_110		Non Converged		0	0.4405	9999	'DBL-G0847-WO'	
FDNS	02G08110	0 11G	G08_110	TO->FROM'	'NORTHWEST - TATONGA7 345.00 345KV CKT 1'	345.00	1195	0.1939	95.7	'DBL-MEDLO-WI'	
FDNS	02G08110	0 11G	G08_110	TO->FROM'	'FINNEY SWITCHING STATION - STEVENSCO	345.00	1052	0.47937	132.1299	'DBL-HIT-G084'	
FDNS	02G08110	0 11G	G08_110	TO->FROM'	'NORTHWEST - TATONGA7 345.00 345KV CKT 1'	345.00	1195	0.21652	95.1	'DBL-WOOD-MED'	
FDNS	02G08110	0 11G	G08_110	TO->FROM'	'FINNEY SWITCHING STATION - STEVENSCO	345.00	1052	0.29125	96.4	'DBL-WOOD-MED'	
FDNS	02G08110	2 11G	G08_110	TO->FROM'	'NORTHWEST - TATONGA7 345.00 345KV CKT 1'	345.00	1195	0.19915	97.3	'DBL-MEDLO-WI'	
FDNS	02G08110	2 11G	G08_110	TO->FROM'	'FINNEY SWITCHING STATION - STEVENSCO	345.00	1052	0.28388	97	'DBL-G0847-WO'	
FDNS	02G08110	2 11G	G08_110	TO->FROM'	'NORTHWEST - TATONGA7 345.00 345KV CKT 1'	345.00	1195	0.22781	98	'DBL-WOOD-MED'	
FNSL-Itera	02G0847	0 11G	G08_110		Non Converged		0	0.43881	9999	'DBL-G0847-WO'	
FDNS	02G0847	0 11G	G08_110	TO->FROM'	'NORTHWEST - TATONGA7 345.00 345KV CKT 1'	345.00	1195	0.19327	97.4	'DBL-MEDLO-WI'	
FDNS	02G0847	0 11G	G08_110	TO->FROM'	'FINNEY SWITCHING STATION - STEVENSCO	345.00	1052	0.4806	128.0221	'DBL-HIT-G084'	
FDNS	02G0847	0 11G	G08_110	TO->FROM'	'NORTHWEST - TATONGA7 345.00 345KV CKT 1'	345.00	1195	0.21576	97.1	'DBL-WOOD-MED'	
FDNS	02G0847	0 11G	G08_110	TO->FROM'	'FINNEY SWITCHING STATION - STEVENSCO	345.00	1052	0.29086	98	'DBL-WOOD-MED'	
FDNS	02G0847	2 11G	G08_110	TO->FROM'	'NORTHWEST - TATONGA7 345.00 345KV CKT 1'	345.00	1195	0.19853	99	'DBL-MEDLO-WI'	
FDNS	02G0847	2 11G	G08_110	TO->FROM'	'NORTHWEST - TATONGA7 345.00 345KV CKT 1'	345.00	1195	0.22705	100	'DBL-WOOD-MED'	
FNSL	02G0847	2 11G	G08_110	TO->FROM'	'FINNEY SWITCHING STATION - STEVENSCO	345.00	1052	0.28324	99.7	'DBL-G0847-WO'	
FDNS	02G1007	0 11G	G08_110	TO->FROM'	'FINNEY SWITCHING STATION - STEVENSCO	345.00	1052	0.48028	128.8406	'DBL-HIT-G084'	
FNSL-Itera	02G1007	0 11G	G08_110		Non Converged		1052	0.2291	77.23053	'FINNEY SWITCHING STATION - STEVENSCO 345.00 345KV CKT 1'	
FNSL-Itera	02G1007	0 11G	G08_110		Non Converged		0	0.44133	9999	'DBL-G0847-WO'	
FDNS	02G1007	2 11G	G08_110	TO->FROM'	'NORTHWEST - TATONGA7 345.00 345KV CKT 1'	345.00	1195	0.19953	96.4	'DBL-MEDLO-WI'	
FDNS	02G1007	2 11G	G08_110	TO->FROM'	'NORTHWEST - TATONGA7 345.00 345KV CKT 1'	345.00	1195	0.22824	96.9	'DBL-WOOD-MED'	
FNSL-Itera	02G1007	2 11G	G08_110		Non Converged		0	0.3189	9999	'DBL-G0847-WO'	
FNSL-Itera	02G1014	0 11G	G08_110		Non Converged		0	0.44028	9999	'DBL-G0847-WO'	
FDNS	02G1014	0 11G	G08_110	TO->FROM'	'NORTHWEST - TATONGA7 345.00 345KV CKT 1'	345.00	1195	0.19378	96	'DBL-MEDLO-WI'	
FDNS	02G1014	0 11G	G08_110	TO->FROM'	'FINNEY SWITCHING STATION - STEVENSCO	345.00	1052	0.47916	133.3729	'DBL-HIT-G084'	
FDNS	02G1014	0 11G	G08_110	TO->FROM'	'NORTHWEST - TATONGA7 345.00 345KV CKT 1'	345.00	1195	0.21641	95.4	'DBL-WOOD-MED'	
FDNS	02G1014	0 11G	G08_110	TO->FROM'	'FINNEY SWITCHING STATION - STEVENSCO	345.00	1052	0.29115	96.9	'DBL-WOOD-MED'	
FDNS	02G1014	2 11G	G08_110	TO->FROM'	'NORTHWEST - TATONGA7 345.00 345KV CKT 1'	345.00	1195	0.19904	97.6	'DBL-MEDLO-WI'	
FDNS	02G1014	2 11G	G08_110	TO->FROM'	'FINNEY SWITCHING STATION - STEVENSCO	345.00	1052	0.28377	97.6	'DBL-G0847-WO'	
FDNS	02G1014	2 11G	G08_110	TO->FROM'	'NORTHWEST - TATONGA7 345.00 345KV CKT 1'	345.00	1195	0.22768	98.3	'DBL-WOOD-MED'	
FDNS	2	0 11G	G08_110	TO->FROM'	'FINNEY SWITCHING STATION - STEVENSCO	345.00	1052	0.4805	128.0433	'DBL-HIT-G084'	
FNSL-Itera	2	0 11G	G08_110		Non Converged		1052	0.22922	76.82405	'FINNEY SWITCHING STATION - STEVENSCO 345.00 345KV CKT 1'	
FNSL-Blow	2	0 11G	G08_110		Non Converged		0	0.44151	9999	'DBL-G0847-WO'	
FDNS	2	2 11G	G08_110	TO->FROM'	'NORTHWEST - TATONGA7 345.00 345KV CKT 1'	345.00	1195	0.19964	96.1	'DBL-MEDLO-WI'	
FDNS	2	2 11G	G08_110	TO->FROM'	'NORTHWEST - TATONGA7 345.00 345KV CKT 1'	345.00	1195	0.22836	96.5	'DBL-WOOD-MED'	
FNSL-Itera	2	2 11G	G08_110		Non Converged		0	0.31905	9999	'DBL-G0847-WO'	

SOLUTION GROUP	SCENARIK	SEASON	SOURCE	DIRECTION	MONITORED ELEMENT	COMMON NAME	RATEB	TDF	TC%	LOAD	CONTINGENCY	NAME
FNSL-Itera 02ALL		0 11G	G08_110		Non Converged		0	0.14833	9999	'DBL-G0847-WO'		
FNSL-Itera 02ALL		0 11G	G08_110		Non Converged		0	0.1269	9999	'SPP-SWPS-02'		
FNSL-Itera 02ALL		0 11G	G08_110		Non Converged		441	0.11741	57.29366	'STLN-DEMARC6230.00 - SWEETWT6	230.00	230KV CKT 1'
FNSL-Itera 02ALL		0 11G	G08_110		Non Converged		0	0.08283	9999	'SPP-SWPS-02'		
FNSL-Itera 02ALL		0 11G	G08_110		Non Converged		0	0.08061	9999	'ATC_B2_8E2_G'		
FNSL-Itera 02ALL		0 11G	G08_110		Non Converged		0	0.07821	9999	'050 1'		
FNSL-Itera 02ALL		0 11G	G08_110		Non Converged		0	0.0755	9999	'ATC_B2_8E2'		
FNSL-Itera 02ALL		0 11G	G08_110		Non Converged		0	0.07387	9999	'050 2'		
FNSL-Itera 02ALL		0 11G	G08_110		Non Converged		441	0.07144	56.82947	'STLN-DEMARC6230.00 - SWEETWT6	230.00	230KV CKT 1'
FNSL-Itera 02ALL		0 11G	G08_110		Non Converged		0	0.05484	9999	'ATC_B2_8E2_G'		
FNSL-Blow 02ALL		0 11G	G08_110		Non Converged		0	0.0529	9999	'050 1'		
FNSL-Itera 02ALL		0 11G	G08_110		Non Converged		0	0.05103	9999	'ATC_B2_8E2'		
FNSL-Itera 02ALL		0 11G	G08_110		Non Converged		0	0.0441	9999	'SPP-SWPS-02'		
FNSL-Itera 02ALL		0 11G	G08_110		Non Converged		441	0.04137	57.2667	'STLN-DEMARC6230.00 - SWEETWT6	230.00	230KV CKT 1'
FNSL-Itera 02ALL		0 11G	G08_110		Non Converged		1052	0.03112	76.82405	'FINNEY SWITCHING STATION - STEVENSCO	345.00	345KV CKT 1'
FNSL-Itera 02ALL		0 11G	G08_110		Non Converged		0	0.02896	9999	'ATC_B2_8E2'		
FNSL-Itera 02ALL		0 11G	G08_110		Non Converged		0	0.02683	9999	'SPP-SWPS-T53'		
FNSL-Itera 02ALL		0 11G	G08_110		Non Converged		0	0.02319	9999	'ATC_B2_8E2_G'		
FNSL-Itera 02ALL		0 11G	G08_110		Non Converged		0	0.02214	9999	'ATC_B2_8E2_G'		
FNSL-Itera 02ALL		0 11G	G08_110		Non Converged		0	0.02182	9999	'ATC_B2_8E2'		
FNSL-Blow 02ALL		0 11G	G08_110		Non Converged		1052	0.22103	97.33807	'FINNEY SWITCHING STATION - STEVENSCO	345.00	345KV CKT 1'
FNSL-Blow 02ALL		0 11G	G08_110		Non Converged		0	0.44949	9999	'DBL-HIT-G084'		
FNSL-Blow 02ALL		0 11G	G08_110		Non Converged		0	0.42793	9999	'DBL-G0847-WO'		
FNSL-Itera 02ALL		2 11G	G08_110		Non Converged		1052	0.18928	82.65054	'FINNEY SWITCHING STATION - STEVENSCO	345.00	345KV CKT 1'
FNSL-Itera 02ALL		2 11G	G08_110		Non Converged		0	0.30841	9999	'DBL-G0847-WO'		
FNSL-Blow 02G08110		0 11G	G08_110		Non Converged		0	0.4405	9999	'DBL-G0847-WO'		
FNSL-Itera 02G08110		0 11G	G08_110		Non Converged		0	0.08283	9999	'SPP-SWPS-02'		
FNSL-Itera 02G08110		0 11G	G08_110		Non Converged		441	0.04142	56.82947	'STLN-DEMARC6230.00 - SWEETWT6	230.00	230KV CKT 1'
FNSL-Itera 02G08110		0 11G	G08_110		Non Converged		441	0.04142	57.15012	'STATELINE INTERCHANGE - STLN-DEMARC6230.00	230KV	CKT 1'
FNSL-Itera 02G08110		3 11G	G08_110		Non Converged		0	0.05248	9999	'SPP-SWPS-03'		
FNSL-Itera 02G0847		0 11G	G08_110		Non Converged		441	0.04139	57.61415	'STATELINE INTERCHANGE - STLN-DEMARC6230.00	230KV	CKT 1'
FNSL-Itera 02G0847		0 11G	G08_110		Non Converged		0	0.43881	9999	'DBL-G0847-WO'		
FNSL-Itera 02G0847		0 11G	G08_110		Non Converged		0	0.08277	9999	'SPP-SWPS-02'		
FNSL-Itera 02G0847		0 11G	G08_110		Non Converged		441	0.04139	57.29366	'STLN-DEMARC6230.00 - SWEETWT6	230.00	230KV CKT 1'
FNSL-Itera 02G0847		0 11G	G08_110		Non Converged		351	0.03741	82.03278	'GRAPEVINE INTERCHANGE - NICHOLS STATION	230KV	CKT 1'
FNSL-Itera 02G0847		3 11G	G08_110		Non Converged		0	0.05245	9999	'SPP-SWPS-03'		
FNSL-Itera 02G1007		0 11G	G08_110		Non Converged		441	0.04144	56.55862	'STLN-DEMARC6230.00 - SWEETWT6	230.00	230KV CKT 1'
FNSL-Itera 02G1007		0 11G	G08_110		Non Converged		441	0.04144	56.87944	'STATELINE INTERCHANGE - STLN-DEMARC6230.00	230KV	CKT 1'
FNSL-Itera 02G1007		0 11G	G08_110		Non Converged		1052	0.2291	77.23053	'FINNEY SWITCHING STATION - STEVENSCO	345.00	345KV CKT 1'
FNSL-Itera 02G1007		0 11G	G08_110		Non Converged		0	0.44133	9999	'DBL-G0847-WO'		
FNSL-Itera 02G1007		0 11G	G08_110		Non Converged		0	0.08287	9999	'SPP-SWPS-02'		
FNSL-Itera 02G1007		2 11G	G08_110		Non Converged		0	0.3189	9999	'DBL-G0847-WO'		
FNSL-Itera 02G1007		3 11G	G08_110		Non Converged		0	0.05249	9999	'SPP-SWPS-03'		
FNSL-Itera 02G1014		0 11G	G08_110		Non Converged		0	0.44028	9999	'DBL-G0847-WO'		
FNSL-Itera 02G1014		0 11G	G08_110		Non Converged		0	0.08274	9999	'SPP-SWPS-02'		
FNSL-Itera 02G1014		0 11G	G08_110		Non Converged		441	0.04137	57.2667	'STLN-DEMARC6230.00 - SWEETWT6	230.00	230KV CKT 1'
FNSL-Itera 02G1014		0 11G	G08_110		Non Converged		351	0.0374	81.98898	'GRAPEVINE INTERCHANGE - NICHOLS STATION	230KV	CKT 1'
FNSL-Itera 02G1014		0 11G	G08_110		Non Converged		441	0.04137	57.58744	'STATELINE INTERCHANGE - STLN-DEMARC6230.00	230KV	CKT 1'
FNSL-Itera 02G1014		3 11G	G08_110		Non Converged		0	0.05243	9999	'SPP-SWPS-03'		
FNSL-Itera 02G1014		0 11G	G08_110		Non Converged		441	0.0415	56.03129	'STLN-DEMARC6230.00 - SWEETWT6	230.00	230KV CKT 1'
FNSL-Itera 02G1014		0 11G	G08_110		Non Converged		441	0.0415	56.34883	'STATELINE INTERCHANGE - STLN-DEMARC6230.00	230KV	CKT 1'
FNSL-Itera 02G1014		0 11G	G08_110		Non Converged		1052	0.22922	76.82405	'FINNEY SWITCHING STATION - STEVENSCO	345.00	345KV CKT 1'
FNSL-Itera 02G1014		2	0 11G	G08_110	Non Converged		0	0.44151	9999	'DBL-G0847-WO'		
FNSL-Itera 02G1014		2	0 11G	G08_110	Non Converged		0	0.083	9999	'SPP-SWPS-02'		
FNSL-Itera 02G1014		2	0 11G	G08_110	Non Converged		0	0.31905	9999	'DBL-G0847-WO'		
FNSL-Itera 02G1014		2	3 11G	G08_110	Non Converged		0	0.0526	9999	'SPP-SWPS-03'		
FNSL-Blow 03ALL		0 11G	G08_110		Non Converged		0	0.18388	9999	'DBL-MEDLO-WI'		
FNSL-Itera 02G1014		6	0 11G	G08_110	Non Converged		0	0.08323	9999	'SPP-SWPS-03'		
FNSL-Itera 02ALL		0 11G	G08_123N		Non Converged		1052	0.17598	76.82405	'FINNEY SWITCHING STATION - STEVENSCO	345.00	345KV CKT 1'
FNSL-Itera 02ALL		0 11G	G08_123N		Non Converged		0	0.13982	9999	'DBL-G0847-WO'		
FNSL-Itera 02ALL		0 11G	G08_123N		Non Converged		1052	0.12109	82.65054	'FINNEY SWITCHING STATION - STEVENSCO	345.00	345KV CKT 1'
FNSL-Itera 02ALL		0 11G	G08_123N		Non Converged		441	0.10556	57.2667	'STLN-DEMARC6230.00 - SWEETWT6	230.00	230KV CKT 1'
FNSL-Itera 02ALL		0 11G	G08_123N		Non Converged		0	0.08065	9999	'ATC_B2_8E2_G'		
FNSL-Itera 02ALL		0 11G	G08_123N		Non Converged		0	0.07831	9999	'050 1'		
FNSL-Itera 02ALL		0 11G	G08_123N		Non Converged		0	0.07559	9999	'ATC_B2_8E2'		
FNSL-Itera 02ALL		0 11G	G08_123N		Non Converged		0	0.07545	9999	'ATC_B2_8E2'		
FNSL-Itera 02ALL		0 11G	G08_123N		Non Converged		0	0.07377	9999	'050 2'		

SOLUTION GROUP	SCENARI	SEASON	SOURCE	DIRECTION	MONITORED ELEMENT	COMMON NAME	RATEB	TDF	TC%	LOAD	CONTINGENCY	NAME
FNSL-Itera 02ALL		0 11G	G08_123N		Non Converged		351	0.06555	82.03278	'GRAPEVINE INTERCHANGE - NICHOLS STATION 230KV CKT 1'		
FNSL-Blow 02ALL		0 11G	G08_123N		Non Converged		0	0.05463	9999	'ATC_B2_8E2_G'		
FNSL-Itera 02ALL		0 11G	G08_123N		Non Converged		0	0.05245	9999	'SPP-SWPS-03'		
FNSL-Itera 02ALL		0 11G	G08_123N		Non Converged		0	0.04963	9999	'050 2'		
FNSL-Itera 02ALL		0 11G	G08_123N		Non Converged		0	0.04149	9999	'SPP-SWPS-T53'		
FNSL-Itera 02ALL		0 11G	G08_123N		Non Converged		0	0.03153	9999	'ATC_B2_8E2_G'		
FNSL-Itera 02ALL		0 11G	G08_123N		Non Converged		0	0.02997	9999	'050 1'		
FNSL-Itera 02ALL		0 11G	G08_123N		Non Converged		0	0.02785	9999	'050 2'		
FNSL-Itera 02ALL		0 11G	G08_123N		Non Converged		0	0.02473	9999	'TRF-STEGALL'		
FNSL-Itera 02ALL		0 11G	G08_123N		Non Converged		0	0.0226	9999	'050 1'		
FNSL-Itera 02ALL		0 11G	G08_123N		Non Converged		441	0.02203	57.15012	'STATELINE INTERCHANGE - STLN-DEMARC6230.00 230KV CKT		
FNSL-Itera 0	0	0 11WP	G08_123N		Non Converged		0	0.0554	9999	'ATC_B2_8E2_G'		
FNSL-Itera 0	0	0 11WP	G08_123N		Non Converged		1793	0.03255	19.91273	'GEN300015 1-1SGPDEL 18.000'		
FNSL-Itera 1	1	0 11G	G08_123N		Non Converged		0	0.0535	9999	'050 1'		
FNSL-Itera 1	1	0 11G	G08_123N		Non Converged		0	0.0502	9999	'050 2'		
FNSL-Itera 1	1	0 11G	G08_123N		Non Converged		0	0.05162	9999	'ATC_B2_8E2'		
FNSL-Itera 1	1	0 11G	G08_123N		Non Converged		0	0.05544	9999	'ATC_B2_8E2_G'		
FNSL-Itera 1	1	2 11G	G08_123N		Non Converged		0	0.05347	9999	'050 1'		
FNSL-Itera 1	1	2 11G	G08_123N		Non Converged		0	0.05017	9999	'050 2'		
FNSL-Itera 1	1	2 11G	G08_123N		Non Converged		0	0.05159	9999	'ATC_B2_8E2'		
FNSL-Itera 1	1	2 11G	G08_123N		Non Converged		0	0.0554	9999	'ATC_B2_8E2_G'		
FNSL-Itera 02ALL		0 11G	G08_123N		Non Converged		0	0.05272	9999	'050 1'		
FNSL-Itera 02ALL		0 11G	G08_123N		Non Converged		0	0.04946	9999	'050 2'		
FNSL-Itera 02ALL		0 11G	G08_123N		Non Converged		0	0.05086	9999	'ATC_B2_8E2'		
FNSL-Itera 02ALL		0 11G	G08_123N		Non Converged		0	0.05463	9999	'ATC_B2_8E2_G'		
FNSL-Itera 02ALL		2 11G	G08_123N		Non Converged		0	0.05275	9999	'050 1'		
FNSL-Itera 02ALL		2 11G	G08_123N		Non Converged		0	0.04949	9999	'050 2'		
FNSL-Itera 02ALL		2 11G	G08_123N		Non Converged		0	0.0509	9999	'ATC_B2_8E2'		
FNSL-Itera 02ALL		2 11G	G08_123N		Non Converged		0	0.05467	9999	'ATC_B2_8E2_G'		
FNSL-Itera 02ALL		3 11G	G08_123N		Non Converged		0	0.05278	9999	'050 1'		
FNSL-Itera 02ALL		3 11G	G08_123N		Non Converged		0	0.04952	9999	'050 2'		
FNSL-Itera 02ALL		3 11G	G08_123N		Non Converged		0	0.05092	9999	'ATC_B2_8E2'		
FNSL-Itera 02ALL		3 11G	G08_123N		Non Converged		0	0.05469	9999	'ATC_B2_8E2_G'		
FNSL-Itera 02G08-123		0 11WP	G08_123N		Non Converged		0	0.05524	9999	'ATC_B2_8E2_G'		
FNSL-Itera 02G08-123		0 11WP	G08_123N		Non Converged		1793	0.03246	20.05894	'GEN300015 1-1SGPDEL 18.000'		
FNSL-Itera 02G08110		0 11G	G08_123N		Non Converged		0	0.05291	9999	'050 1'		
FNSL-Itera 02G08110		0 11G	G08_123N		Non Converged		0	0.04965	9999	'050 2'		
FNSL-Itera 02G08110		0 11G	G08_123N		Non Converged		0	0.05105	9999	'ATC_B2_8E2'		
FNSL-Itera 02G08110		0 11G	G08_123N		Non Converged		0	0.05483	9999	'ATC_B2_8E2_G'		
FNSL-Itera 02G08110		2 11G	G08_123N		Non Converged		0	0.05292	9999	'050 1'		
FNSL-Itera 02G08110		2 11G	G08_123N		Non Converged		0	0.04966	9999	'050 2'		
FNSL-Itera 02G08110		2 11G	G08_123N		Non Converged		0	0.05106	9999	'ATC_B2_8E2'		
FNSL-Itera 02G08110		2 11G	G08_123N		Non Converged		0	0.05484	9999	'ATC_B2_8E2_G'		
FNSL-Itera 02G08110		3 11G	G08_123N		Non Converged		0	0.05291	9999	'050 1'		
FNSL-Itera 02G08110		3 11G	G08_123N		Non Converged		0	0.04964	9999	'050 2'		
FNSL-Itera 02G08110		3 11G	G08_123N		Non Converged		0	0.05104	9999	'ATC_B2_8E2'		
FNSL-Itera 02G08110		3 11G	G08_123N		Non Converged		0	0.05482	9999	'ATC_B2_8E2_G'		
FNSL-Itera 02G0847		0 11G	G08_123N		Non Converged		0	0.05289	9999	'050 1'		
FNSL-Itera 02G0847		0 11G	G08_123N		Non Converged		0	0.04962	9999	'050 2'		
FNSL-Itera 02G0847		0 11G	G08_123N		Non Converged		0	0.05103	9999	'ATC_B2_8E2'		
FNSL-Itera 02G0847		0 11G	G08_123N		Non Converged		0	0.0548	9999	'ATC_B2_8E2_G'		
FNSL-Itera 02G0847		2 11G	G08_123N		Non Converged		0	0.0529	9999	'050 1'		
FNSL-Itera 02G0847		2 11G	G08_123N		Non Converged		0	0.04963	9999	'050 2'		
FNSL-Itera 02G0847		2 11G	G08_123N		Non Converged		0	0.05104	9999	'ATC_B2_8E2'		
FNSL-Itera 02G0847		2 11G	G08_123N		Non Converged		0	0.05481	9999	'ATC_B2_8E2_G'		
FNSL-Itera 02G0847		3 11G	G08_123N		Non Converged		0	0.05289	9999	'050 1'		
FNSL-Itera 02G0847		3 11G	G08_123N		Non Converged		0	0.04962	9999	'050 2'		
FNSL-Itera 02G0847		3 11G	G08_123N		Non Converged		0	0.05102	9999	'ATC_B2_8E2'		
FNSL-Itera 02G0847		3 11G	G08_123N		Non Converged		0	0.0548	9999	'ATC_B2_8E2_G'		
FNSL-Itera 02G1007		0 11G	G08_123N		Non Converged		0	0.0529	9999	'050 1'		
FNSL-Itera 02G1007		0 11G	G08_123N		Non Converged		0	0.04964	9999	'050 2'		
FNSL-Itera 02G1007		0 11G	G08_123N		Non Converged		0	0.05104	9999	'ATC_B2_8E2'		
FNSL-Itera 02G1007		0 11G	G08_123N		Non Converged		0	0.05482	9999	'ATC_B2_8E2_G'		
FNSL-Itera 02G1007		2 11G	G08_123N		Non Converged		0	0.05291	9999	'050 1'		
FNSL-Itera 02G1007		2 11G	G08_123N		Non Converged		0	0.04964	9999	'050 2'		
FNSL-Itera 02G1007		2 11G	G08_123N		Non Converged		0	0.05105	9999	'ATC_B2_8E2'		
FNSL-Itera 02G1007		2 11G	G08_123N		Non Converged		0	0.05483	9999	'ATC_B2_8E2_G'		

SOLUTION GROUP	SCENARI SEASON	SOURCE	DIRECTION	MONITORED ELEMENT	COMMON NAME	RATEB	TDF	TC%	LOAD	CONTINGENCY	NAME
FNSL-Itera 02G1007	3 11G	G08_123N		Non Converged		0	0.0529	9999	'050	1'	
FNSL-Itera 02G1007	3 11G	G08_123N		Non Converged		0	0.04963	9999	'050	2'	
FNSL-Itera 02G1007	3 11G	G08_123N		Non Converged		0	0.05104	9999	'ATC_B2_8E2'		
FNSL-Itera 02G1007	3 11G	G08_123N		Non Converged		0	0.05481	9999	'ATC_B2_8E2_G'		
FNSL-Itera 02G1014	0 11G	G08_123N		Non Converged		0	0.05289	9999	'050	1'	
FNSL-Itera 02G1014	0 11G	G08_123N		Non Converged		0	0.04962	9999	'050	2'	
FNSL-Itera 02G1014	0 11G	G08_123N		Non Converged		0	0.05103	9999	'ATC_B2_8E2'		
FNSL-Itera 02G1014	0 11G	G08_123N		Non Converged		0	0.05481	9999	'ATC_B2_8E2_G'		
FNSL-Itera 02G1014	2 11G	G08_123N		Non Converged		0	0.0529	9999	'050	1'	
FNSL-Itera 02G1014	2 11G	G08_123N		Non Converged		0	0.04963	9999	'050	2'	
FNSL-Itera 02G1014	2 11G	G08_123N		Non Converged		0	0.05104	9999	'ATC_B2_8E2'		
FNSL-Itera 02G1014	2 11G	G08_123N		Non Converged		0	0.05482	9999	'ATC_B2_8E2_G'		
FNSL-Itera 02G1014	3 11G	G08_123N		Non Converged		0	0.05289	9999	'050	1'	
FNSL-Itera 02G1014	3 11G	G08_123N		Non Converged		0	0.04962	9999	'050	2'	
FNSL-Itera 02G1014	3 11G	G08_123N		Non Converged		0	0.05103	9999	'ATC_B2_8E2'		
FNSL-Itera 02G1014	3 11G	G08_123N		Non Converged		0	0.0548	9999	'ATC_B2_8E2_G'		
FNSL-Itera 2	0 11G	G08_123N		Non Converged		0	0.05291	9999	'050	1'	
FNSL-Itera 2	0 11G	G08_123N		Non Converged		0	0.04964	9999	'050	2'	
FNSL-Itera 2	0 11G	G08_123N		Non Converged		0	0.05105	9999	'ATC_B2_8E2'		
FNSL-Itera 2	0 11G	G08_123N		Non Converged		0	0.05482	9999	'ATC_B2_8E2_G'		
FNSL-Itera 2	2 11G	G08_123N		Non Converged		0	0.05292	9999	'050	1'	
FNSL-Itera 2	2 11G	G08_123N		Non Converged		0	0.04965	9999	'050	2'	
FNSL-Itera 2	2 11G	G08_123N		Non Converged		0	0.05105	9999	'ATC_B2_8E2'		
FNSL-Itera 2	2 11G	G08_123N		Non Converged		0	0.05483	9999	'ATC_B2_8E2_G'		
FNSL-Itera 2	3 11G	G08_123N		Non Converged		0	0.0529	9999	'050	1'	
FNSL-Itera 2	3 11G	G08_123N		Non Converged		0	0.04963	9999	'050	2'	
FNSL-Itera 2	3 11G	G08_123N		Non Converged		0	0.05104	9999	'ATC_B2_8E2'		
FNSL-Itera 2	3 11G	G08_123N		Non Converged		0	0.05482	9999	'ATC_B2_8E2_G'		
FNSL-Blow 03ALL	0 11G	G08_123N		Non Converged		0	0.07426	9999	'DBL-SPRVL-CO'		
FNSL-Blow 03ALL	0 11G	G08_123N		Non Converged		0	0.07426	9999	'DBL-COM-MEDL'		
FNSL-Itera 03ALL	0 11G	G08_123N		Non Converged		0	0.05191	9999	'050	1'	
FNSL-Itera 03ALL	0 11G	G08_123N		Non Converged		0	0.0487	9999	'050	2'	
FNSL-Itera 03ALL	0 11G	G08_123N		Non Converged		0	0.05008	9999	'ATC_B2_8E2'		
FNSL-Itera 03ALL	0 11G	G08_123N		Non Converged		0	0.05379	9999	'ATC_B2_8E2_G'		
FNSL-Itera 3	0 11G	G08_123N		Non Converged		0	0.0524	9999	'050	1'	
FNSL-Itera 3	0 11G	G08_123N		Non Converged		0	0.04917	9999	'050	2'	
FNSL-Itera 3	0 11G	G08_123N		Non Converged		0	0.05056	9999	'ATC_B2_8E2'		
FNSL-Itera 3	0 11G	G08_123N		Non Converged		0	0.05429	9999	'ATC_B2_8E2_G'		
FNSL-Itera 3	2 11G	G08_123N		Non Converged		0	0.0524	9999	'050	1'	
FNSL-Itera 3	2 11G	G08_123N		Non Converged		0	0.04917	9999	'050	2'	
FNSL-Itera 3	2 11G	G08_123N		Non Converged		0	0.05056	9999	'ATC_B2_8E2'		
FNSL-Itera 3	2 11G	G08_123N		Non Converged		0	0.0543	9999	'ATC_B2_8E2_G'		
FNSL-Itera 5	0 11G	G08_123N		Non Converged		0	0.05339	9999	'050	1'	
FNSL-Itera 5	0 11G	G08_123N		Non Converged		0	0.0501	9999	'050	2'	
FNSL-Itera 5	0 11G	G08_123N		Non Converged		0	0.05151	9999	'ATC_B2_8E2'		
FNSL-Itera 5	0 11G	G08_123N		Non Converged		0	0.05532	9999	'ATC_B2_8E2_G'		
FNSL-Itera 6	0 11G	G08_123N		Non Converged		0	0.05355	9999	'050	1'	
FNSL-Itera 6	0 11G	G08_123N		Non Converged		0	0.05025	9999	'050	2'	
FNSL-Itera 6	0 11G	G08_123N		Non Converged		0	0.05167	9999	'ATC_B2_8E2'		
FNSL-Itera 6	0 11G	G08_123N		Non Converged		0	0.05549	9999	'ATC_B2_8E2_G'		
FNSL-Itera 7	0 11G	G08_123N		Non Converged		0	0.05378	9999	'050	1'	
FNSL-Itera 7	0 11G	G08_123N		Non Converged		0	0.05046	9999	'050	2'	
FNSL-Itera 7	0 11G	G08_123N		Non Converged		0	0.05189	9999	'ATC_B2_8E2'		
FNSL-Itera 7	0 11G	G08_123N		Non Converged		0	0.05573	9999	'ATC_B2_8E2_G'		
FNSL-Itera 7	2 11G	G08_123N		Non Converged		0	0.05378	9999	'050	1'	
FNSL-Itera 7	2 11G	G08_123N		Non Converged		0	0.05046	9999	'050	2'	
FNSL-Itera 7	2 11G	G08_123N		Non Converged		0	0.05189	9999	'ATC_B2_8E2'		
FNSL-Itera 7	2 11G	G08_123N		Non Converged		0	0.05573	9999	'ATC_B2_8E2_G'		
FNSL-Itera 8	0 11G	G08_123N		Non Converged		0	0.05361	9999	'050	1'	
FNSL-Itera 8	0 11G	G08_123N		Non Converged		0	0.05031	9999	'050	2'	
FNSL-Itera 8	0 11G	G08_123N		Non Converged		0	0.05173	9999	'ATC_B2_8E2'		
FNSL-Itera 8	0 11G	G08_123N		Non Converged		0	0.05555	9999	'ATC_B2_8E2_G'		
FNSL-Itera 9	0 11G	G08_123N		Non Converged		0	0.0522	9999	'050	1'	
FNSL-Itera 9	0 11G	G08_123N		Non Converged		0	0.04897	9999	'050	2'	
FNSL-Itera 9	0 11G	G08_123N		Non Converged		0	0.05036	9999	'ATC_B2_8E2'		
FNSL-Itera 9	0 11G	G08_123N		Non Converged		0	0.0541	9999	'ATC_B2_8E2_G'		
FNSL-Itera 9	2 11G	G08_123N		Non Converged		0	0.05223	9999	'050	1'	

SOLUTION GROUP	SCENARI	SEASON	SOURCE	DIRECTION	MONITORED ELEMENT	COMMON NAME	RATEB	TDF	TC%	LOAD	CONTINGENCY	NAME
FNSL-Itera	9	2	11G		G08_123N	Non Converged	0	0.049	9999	'050	2'	
FNSL-Itera	9	2	11G		G08_123N	Non Converged	0	0.05039	9999	'ATC_B2_8E2'		
FNSL-Itera	9	2	11G		G08_123N	Non Converged	0	0.05412	9999	'ATC_B2_8E2_G'		
FNSL-Itera	11	0	11G		G08_123N	Non Converged	0	0.05311	9999	'050	1'	
FNSL-Itera	11	0	11G		G08_123N	Non Converged	0	0.04983	9999	'050	2'	
FNSL-Itera	11	0	11G		G08_123N	Non Converged	0	0.05124	9999	'ATC_B2_8E2'		
FNSL-Itera	11	0	11G		G08_123N	Non Converged	0	0.05503	9999	'ATC_B2_8E2_G'		
FNSL-Itera	11	2	11G		G08_123N	Non Converged	0	0.05311	9999	'050	1'	
FNSL-Itera	11	2	11G		G08_123N	Non Converged	0	0.04983	9999	'050	2'	
FNSL-Itera	11	2	11G		G08_123N	Non Converged	0	0.05124	9999	'ATC_B2_8E2'		
FNSL-Itera	11	2	11G		G08_123N	Non Converged	0	0.05503	9999	'ATC_B2_8E2_G'		
FNSL-Itera	13	0	11G		G08_123N	Non Converged	0	0.05286	9999	'050	1'	
FNSL-Itera	13	0	11G		G08_123N	Non Converged	0	0.04962	9999	'050	2'	
FNSL-Itera	13	0	11G		G08_123N	Non Converged	0	0.051	9999	'ATC_B2_8E2'		
FNSL-Itera	13	0	11G		G08_123N	Non Converged	0	0.05476	9999	'ATC_B2_8E2_G'		
FNSL-Itera	14	0	11G		G08_123N	Non Converged	0	0.05367	9999	'050	1'	
FNSL-Itera	14	0	11G		G08_123N	Non Converged	0	0.05035	9999	'050	2'	
FNSL-Itera	14	0	11G		G08_123N	Non Converged	0	0.05178	9999	'ATC_B2_8E2'		
FNSL-Itera	14	0	11G		G08_123N	Non Converged	0	0.05561	9999	'ATC_B2_8E2_G'		
FNSL-Itera 15G08123	0	11G	G08_123N		G08_123N	Non Converged	0	0.05348	9999	'050	1'	
FNSL-Itera 15G08123	0	11G	G08_123N		G08_123N	Non Converged	0	0.05018	9999	'050	2'	
FNSL-Itera 15G08123	0	11G	G08_123N		G08_123N	Non Converged	0	0.0516	9999	'ATC_B2_8E2'		
FNSL-Itera 15G08123	0	11G	G08_123N		G08_123N	Non Converged	0	0.05541	9999	'ATC_B2_8E2_G'		
FNSL-Itera	15	0	11G		G08_123N	Non Converged	0	0.05352	9999	'050	1'	
FNSL-Itera	15	0	11G		G08_123N	Non Converged	0	0.05021	9999	'050	2'	
FNSL-Itera	15	0	11G		G08_123N	Non Converged	0	0.05163	9999	'ATC_B2_8E2'		
FNSL-Itera	15	0	11G		G08_123N	Non Converged	0	0.05545	9999	'ATC_B2_8E2_G'		
FDNS	11	0	11G		G09_008	'TO->FROM'	88	0.35287	109.1085	'POSTROCK6	230.00	- S HAYS6 230.00 230KV CKT 1'
FDNS	11	0	11G		G09_008	'TO->FROM'	88	0.35287	109.1085	'POSTROCK6	230.00	- S HAYS6 230.00 230KV CKT 1'
FDNS	11	2	11G		G09_008	'FROM->TO'	319	0.29874	96.7	'POSTROCK7	345.00	(POSTROCK T1) 345/230/13.8KV TRANSFC
FDNS	11	2	11G		G09_008	'FROM->TO'	319	0.29874	96.7	'POSTROCK7	345.00	(POSTROCK T1) 345/230/13.8KV TRANSFC
FDNS	11G0908	0	11G		G09_008	'TO->FROM'	88	0.35236	125.0541	'POSTROCK6	230.00	- S HAYS6 230.00 230KV CKT 1'
FDNS	11G0908	0	11G		G09_008	'FROM->TO'	88	0.35236	106.3964	'POSTROCK6	230.00	- S HAYS6 230.00 230KV CKT 1'
FDNS	11G0908	0	11G		G09_008	'FROM->TO'	319	0.2983	100.3287	'POSTROCK7	345.00	(POSTROCK T1) 345/230/13.8KV TRANSFC
FDNS	11G0908	0	11G		G09_008	'TO->FROM'	88	0.35236	125.0541	'POSTROCK6	230.00	- S HAYS6 230.00 230KV CKT 1'
FDNS	11G0908	0	11G		G09_008	'FROM->TO'	88	0.35236	106.3964	'POSTROCK6	230.00	- S HAYS6 230.00 230KV CKT 1'
FDNS	11G0908	0	11G		G09_008	'FROM->TO'	319	0.2983	100.3287	'POSTROCK7	345.00	(POSTROCK T1) 345/230/13.8KV TRANSFC
FDNS	11G0908	2	11G		G09_008	'FROM->TO'	319	0.29831	100.3374	'POSTROCK7	345.00	(POSTROCK T1) 345/230/13.8KV TRANSFC
FDNS	11G0908	2	11G		G09_008	'FROM->TO'	319	0.29831	100.3374	'POSTROCK7	345.00	(POSTROCK T1) 345/230/13.8KV TRANSFC
FNSL-Itera 02ALL	0	11G	G09_008		G09_008	Non Converged	0	0.15046	9999	'DBL-G0847-WO'		
FNSL-Itera 02ALL	0	11G	G09_008		G09_008	Non Converged	0	0.12692	9999	'SPP-SWPS-03'		
FNSL-Itera 02ALL	0	11G	G09_008		G09_008	Non Converged	441	0.11744	57.15012	'STATELINE INTERCHANGE - STLN-DEMARC6230.00	230KV CKT	
FNSL-Itera 02ALL	0	11G	G09_008		G09_008	Non Converged	0	0.08287	9999	'SPP-SWPS-02'		
FNSL-Itera 02ALL	0	11G	G09_008		G09_008	Non Converged	0	0.08061	9999	'ATC_B2_8E2_G'		
FNSL-Itera 02ALL	0	11G	G09_008		G09_008	Non Converged	0	0.07822	9999	'050	1'	
FNSL-Itera 02ALL	0	11G	G09_008		G09_008	Non Converged	0	0.0755	9999	'ATC_B2_8E2'		
FNSL-Itera 02ALL	0	11G	G09_008		G09_008	Non Converged	0	0.07388	9999	'050	2'	
FNSL-Itera 02ALL	0	11G	G09_008		G09_008	Non Converged	441	0.07146	56.55862	'STLN-DEMARC6230.00 - SWEETWT6	230.00 230KV CKT 1'	
FNSL-Itera 02ALL	0	11G	G09_008		G09_008	Non Converged	441	0.06332	57.2667	'STLN-DEMARC6230.00 - SWEETWT6	230.00 230KV CKT 1'	
FNSL-Blow 02ALL	0	11G	G09_008		G09_008	Non Converged	0	0.0529	9999	'050	1'	
FNSL-Itera 02ALL	0	11G	G09_008		G09_008	Non Converged	0	0.05104	9999	'ATC_B2_8E2'		
FNSL-Itera 02ALL	0	11G	G09_008		G09_008	Non Converged	0	0.04423	9999	'SPP-SWPS-02'		
FNSL-Itera 02ALL	0	11G	G09_008		G09_008	Non Converged	441	0.04139	57.29366	'STLN-DEMARC6230.00 - SWEETWT6	230.00 230KV CKT 1'	
FNSL-Itera 02ALL	0	11G	G09_008		G09_008	Non Converged	0	0.03129	9999	'ATC_B2_8E2_G'		
FNSL-Itera 02ALL	0	11G	G09_008		G09_008	Non Converged	0	0.02897	9999	'ATC_B2_8E2'		
FNSL-Itera 02ALL	0	11G	G09_008		G09_008	Non Converged	0	0.02762	9999	'050	2'	
FNSL-Itera 02ALL	0	11G	G09_008		G09_008	Non Converged	0	0.02329	9999	'ATC_B2_8E2_G'		
FNSL-Itera 02ALL	0	11G	G09_008		G09_008	Non Converged	0	0.02216	9999	'ATC_B2_8E2_G'		
FNSL-Itera 02ALL	0	11G	G09_008		G09_008	Non Converged	0	0.02183	9999	'ATC_B2_8E2'		
FNSL-Blow 00G09_001	0	16SP	G09_008		G09_008	Non Converged	0	0.03037	9999	'TRF-STEGALL'		
FNSL-Blow	0	0	16SP		G09_008	Non Converged	0	0.0305	9999	'TRF-STEGALL'		
FNSL-Blow 03ALL	0	11G	G09_008		G09_008	Non Converged	0	0.20653	9999	'DBL-SPRVL-CO'		
FNSL-Blow 03ALL	0	11G	G09_008		G09_008	Non Converged	0	0.20653	9999	'DBL-COM-MEDL'		
FNSL-Blow 03ALL	0	11G	G09_008		G09_008	Non Converged	0	0.08134	9999	'DBL-MEDLO-WI'		
FDNS	3	0	11G		G09_020	'TO->FROM'	319	0.20465	118.0839	'DBL-SPRVL-CO'		
FDNS	3	0	11G		G09_020	'TO->FROM'	319	0.20465	118.0643	'DBL-COM-MEDL'		
FDNS	3	0	11G		G09_020	'TO->FROM'	319	0.20465	118.0839	'DBL-SPRVL-CO'		

SOLUTION GROUP	SCENARI	SEASON	SOURCE	DIRECTION	MONITORED ELEMENT	COMMON NAME	RATEB	TDF	TC%	LOAD	CONTINGENCY	NAME
FDNS	3	0	11G	G09_020	'TO->FROM'	'CIRCLE - MULLERGRE	319	0.20465	118.0643	'DBL-COM-MEDL'		
FDNS	3	2	11G	G09_020	'TO->FROM'	'CIRCLE - MULLERGRE	319	0.20458	118.1544	'DBL-SPRVL-CO'		
FDNS	3	2	11G	G09_020	'TO->FROM'	'CIRCLE - MULLERGRE	319	0.20458	118.162	'DBL-COM-MEDL'		
FDNS	3	2	11G	G09_020	'TO->FROM'	'CIRCLE - MULLERGRE	319	0.20458	118.1544	'DBL-SPRVL-CO'		
FDNS	3	2	11G	G09_020	'TO->FROM'	'CIRCLE - MULLERGRE	319	0.20458	118.162	'DBL-COM-MEDL'		
FDNS	02G0847	0	11G	G09_020	'TO->FROM'	'CIRCLE - MULLERGRE	319	0.19141	95.9	'DBL-MEDLO-WI'		
FNSL-Itera 02ALL		0	11G	G09_020		Non Converged	1052	0.14363	76.82405	'FINNEY SWITCHING STATION - STEVENSCO	345.00	345KV CKT
FNSL-Itera 02ALL		0	11G	G09_020		Non Converged	0	0.12677	9999	'SPP-SWPS-02'		
FNSL-Itera 02ALL		0	11G	G09_020		Non Converged	0	0.11695	9999	'DBL-G0847-WO'		
FNSL-Itera 02ALL		0	11G	G09_020		Non Converged	0	0.08274	9999	'SPP-SWPS-02'		
FNSL-Itera 02ALL		0	11G	G09_020		Non Converged	0	0.08061	9999	'ATC_B2_8E2_G'		
FNSL-Itera 02ALL		0	11G	G09_020		Non Converged	0	0.0782	9999	'050 1'		
FNSL-Itera 02ALL		0	11G	G09_020		Non Converged	0	0.07549	9999	'ATC_B2_8E2'		
FNSL-Itera 02ALL		0	11G	G09_020		Non Converged	0	0.07381	9999	'050 2'		
FNSL-Itera 02ALL		0	11G	G09_020		Non Converged	441	0.07141	57.29366	'STLN-DEMARC6230.00 - SWEETWT6	230.00	230KV CKT 1'
FNSL-Itera 02ALL		0	11G	G09_020		Non Converged	0	0.05483	9999	'ATC_B2_8E2_G'		
FNSL-Blow 02ALL		0	11G	G09_020		Non Converged	0	0.05289	9999	'050 1'		
FNSL-Itera 02ALL		0	11G	G09_020		Non Converged	0	0.05102	9999	'ATC_B2_8E2'		
FNSL-Itera 02ALL		0	11G	G09_020		Non Converged	0	0.044	9999	'SPP-SWPS-02'		
FNSL-Itera 02ALL		0	11G	G09_020		Non Converged	441	0.04137	57.58744	'STATELINE INTERCHANGE - STLN-DEMARC6230.00	230KV	CKT
FNSL-Itera 02ALL		0	11G	G09_020		Non Converged	1052	0.03101	77.23053	'FINNEY SWITCHING STATION - STEVENSCO	345.00	345KV CKT
FNSL-Itera 02ALL		0	11G	G09_020		Non Converged	0	0.02893	9999	'ATC_B2_8E2'		
FNSL-Itera 02ALL		0	11G	G09_020		Non Converged	1052	0.02614	77.23053	'FINNEY SWITCHING STATION - STEVENSCO	345.00	345KV CKT
FNSL-Itera 02ALL		0	11G	G09_020		Non Converged	0	0.02318	9999	'ATC_B2_8E2_G'		
FNSL-Itera 02ALL		0	11G	G09_020		Non Converged	441	0.02212	56.03129	'STLN-DEMARC6230.00 - SWEETWT6	230.00	230KV CKT 1'
FNSL-Itera 02ALL		0	11G	G09_020		Non Converged	0	0.02181	9999	'ATC_B2_8E2'		
FNSL-Itera 00G09_02(0	11WP	G09_020		Non Converged	0	0.03091	9999	'TRF-STEGALL'		
FNSL-Blow 00G09_02(0	16SP	G09_020		Non Converged	0	0.03372	9999	'TRF-STEGALL'		
FNSL-Itera 00G09_02(0	16WP	G09_020		Non Converged	0	0.03188	9999	'TRF-STEGALL'		
FNSL-Blow	0	0	16SP	G09_020		Non Converged	0	0.03375	9999	'TRF-STEGALL'		
FNSL-Itera	0	0	11WP	G09_020		Non Converged	0	0.03096	9999	'TRF-STEGALL'		
FNSL-Blow	0	0	16WP	G09_020		Non Converged	0	0.03193	9999	'TRF-STEGALL'		
FNSL-Itera	1	0	11G	G09_020		Non Converged	0	0.03147	9999	'TRF-STEGALL'		
FNSL-Itera	1	2	11G	G09_020		Non Converged	0	0.03117	9999	'TRF-STEGALL'		
FNSL-Blow 03ALL		0	11G	G09_020		Non Converged	0	0.17411	9999	'DBL-SPRVL-CO'		
FNSL-Blow 03ALL		0	11G	G09_020		Non Converged	0	0.17411	9999	'DBL-COM-MEDL'		
FNSL-Blow 03ALL		0	11G	G09_020		Non Converged	0	0.09184	9999	'DBL-MEDLO-WI'		
FNSL-Itera	5	0	11G	G09_020		Non Converged	0	0.03141	9999	'TRF-STEGALL'		
FNSL-Itera	6	0	11G	G09_020		Non Converged	0	0.03177	9999	'TRF-STEGALL'		
FNSL-Itera	7	0	11G	G09_020		Non Converged	0	0.03196	9999	'TRF-STEGALL'		
FNSL-Itera	7	2	11G	G09_020		Non Converged	0	0.03196	9999	'TRF-STEGALL'		
FNSL-Itera	8	0	11G	G09_020		Non Converged	0	0.03216	9999	'TRF-STEGALL'		
FNSL-Itera	9	0	11G	G09_020		Non Converged	0	0.03309	9999	'TRF-STEGALL'		
FNSL-Itera	9	2	11G	G09_020		Non Converged	0	0.03308	9999	'TRF-STEGALL'		
FNSL-Itera 11G0920		0	11G	G09_020		Non Converged	0	0.03158	9999	'TRF-STEGALL'		
FNSL-Itera	11	0	11G	G09_020		Non Converged	0	0.0316	9999	'TRF-STEGALL'		
FNSL-Itera	11	2	11G	G09_020		Non Converged	0	0.0316	9999	'TRF-STEGALL'		
FNSL-Itera	13	0	11G	G09_020		Non Converged	0	0.03261	9999	'TRF-STEGALL'		
FNSL-Itera	14	0	11G	G09_020		Non Converged	0	0.03223	9999	'TRF-STEGALL'		
FNSL-Itera	15	0	11G	G09_020		Non Converged	0	0.03217	9999	'TRF-STEGALL'		
FDNS	7	0	11G	G09_030	'TO->FROM'	'SOUTHWESTERN STATION - WASHITA 138KV CKT 1'	260	0.22396	107.3589	'BASE CASE'		
FDNS	7	0	11G	G09_030	'TO->FROM'	'HYDRO - WEATHERFORD 138KV CKT 1'	179	0.53285	110.1846	'HINTON - WEATHERFORD JCT. 138KV CKT 1'		
FDNS	7	0	11G	G09_030	'TO->FROM'	'HYDRO - WEATHERFORD 138KV CKT 1'	179	0.53285	109.9607	'CAN_GAS4 138.00 - HINTON 138KV CKT 1'		
FDNS	7	0	11G	G09_030	'TO->FROM'	'GRACMNT4 138.00 - WASHITA 138KV CKT 1'	228	0.38784	146.7726	'SOUTHWESTERN STATION - WASHITA 138KV CKT 1'		
FDNS	7	0	11G	G09_030	'TO->FROM'	'HYDRO - WEATHERFORD 138KV CKT 1'	179	0.99281	109.1505	'CLINTON JUNCTION - G07-32T 138.00 138KV CKT 1'		
FDNS	7	0	11G	G09_030	'TO->FROM'	'HYDRO - WEATHERFORD 138KV CKT 1'	179	0.53285	113.1714	'WEATHERFORD JCT. - WEATHERFORD SOUTHEAST 138KV CKT 1'		
FDNS	7	0	11G	G09_030	'TO->FROM'	'HYDRO - WEATHERFORD 138KV CKT 1'	179	0.49883	100.7297	'WEATHERFORD TAP - WEATHERFORD WIND FARM 138KV CKT 1'		
FDNS	7	0	11G	G09_030	'TO->FROM'	'HYDRO - WEATHERFORD 138KV CKT 1'	179	0.53285	109.1131	'CAN_GAS4 138.00 - JENSEN ROAD 138KV CKT 1'		
FDNS	7	0	11G	G09_030	'TO->FROM'	'SOUTHWESTERN STATION - WASHITA 138KV CKT 1'	260	0.40085	134.8215	'GRACMNT4 138.00 - WASHITA 138KV CKT 1'		
FDNS	7	0	11G	G09_030	'TO->FROM'	'HINTON - WEATHERFORD JCT. 138KV CKT 1'	210	0.37346	101.2292	'BINGER NIJECT - ONEY 138KV CKT 1'		
FDNS	7	0	11G	G09_030	'TO->FROM'	'CLINTON JUNCTION - G07-32T 138.00 138KV CKT 1'	143	0.99281	122.7317	'BINGER NIJECT - ONEY 138KV CKT 1'		
FDNS	7	0	11G	G09_030	'TO->FROM'	'WEATHERFORD JCT. - WEATHERFORD SOUTHEAST	210	0.37346	108.0455	'BINGER NIJECT - ONEY 138KV CKT 1'		
FDNS	7	0	11G	G09_030	'FROM->TO'	'CAN_GAS4 138.00 - JENSEN ROAD 138KV CKT 1'	191	0.37346	108.8038	'BINGER NIJECT - ONEY 138KV CKT 1'		
FDNS	7	0	11G	G09_030	'TO->FROM'	'HINTON - WEATHERFORD JCT. 138KV CKT 1'	210	0.37346	102.5419	'BINGER NIJECT - SICKLES 138KV CKT 1'		
FDNS	7	0	11G	G09_030	'TO->FROM'	'CLINTON JUNCTION - G07-32T 138.00 138KV CKT 1'	143	0.99281	127.8357	'BINGER NIJECT - SICKLES 138KV CKT 1'		
FDNS	7	0	11G	G09_030	'TO->FROM'	'WEATHERFORD JCT. - WEATHERFORD SOUTHEAST	210	0.37346	109.3683	'BINGER NIJECT - SICKLES 138KV CKT 1'		
FDNS	7	0	11G	G09_030	'FROM->TO'	'CAN_GAS4 138.00 - JENSEN ROAD 138KV CKT 1'	191	0.37346	110.249	'BINGER NIJECT - SICKLES 138KV CKT 1'		

SOLUTION GROUP	SCENARIK	SEASON	SOURCE	DIRECTION	MONITORED ELEMENT	COMMON NAME	RATEB	TDF	TC%	LOAD	CONTINGENCY	NAME
FDNS	7	0 11G	G09_030	TO->FROM'	'HINTON - WEATHERFORD JCT. 138KV CKT 1'		210	0.37346	103.837	'HYDRO - SICKLES 138KV CKT 1'		
FDNS	7	0 11G	G09_030	TO->FROM'	'CLINTON JUNCTION - G07-32T 138.00 138KV CKT 1'		143	0.99281	132.9031	'HYDRO - SICKLES 138KV CKT 1'		
FDNS	7	0 11G	G09_030	TO->FROM'	'WEATHERFORD JCT. - WEATHERFORD SOUTHEAST		210	0.37346	110.6738	'HYDRO - SICKLES 138KV CKT 1'		
FDNS	7	0 11G	G09_030	FROM->TO'	'CAN_GAS4 138.00 - JENSEN ROAD 138KV CKT 1'		191	0.37346	111.675	'HYDRO - SICKLES 138KV CKT 1'		
FDNS	7	0 11G	G09_030	FROM->TO'	'JENSEN ROAD - JENSEN TAP 138KV CKT 1'		191	0.34373	100	'HYDRO - SICKLES 138KV CKT 1'		
FDNS	7	0 11G	G09_030	TO->FROM'	'HINTON - WEATHERFORD JCT. 138KV CKT 1'		210	0.37346	104.5236	'HYDRO - WEATHERFORD 138KV CKT 1'		
FDNS	7	0 11G	G09_030	TO->FROM'	'CLINTON JUNCTION - G07-32T 138.00 138KV CKT 1'		143	0.99281	135.6347	'HYDRO - WEATHERFORD 138KV CKT 1'		
FDNS	7	0 11G	G09_030	TO->FROM'	'WEATHERFORD JCT. - WEATHERFORD SOUTHEAST		210	0.37346	111.3666	'HYDRO - WEATHERFORD 138KV CKT 1'		
FDNS	7	0 11G	G09_030	FROM->TO'	'CAN_GAS4 138.00 - JENSEN ROAD 138KV CKT 1'		191	0.37346	112.4296	'HYDRO - WEATHERFORD 138KV CKT 1'		
FDNS	7	0 11G	G09_030	FROM->TO'	'JENSEN ROAD - JENSEN TAP 138KV CKT 1'		191	0.34373	100.7002	'HYDRO - WEATHERFORD 138KV CKT 1'		
FDNS	7	0 11G	G09_030	TO->FROM'	'HINTON - WEATHERFORD JCT. 138KV CKT 1'		210	0.37346	100.7762	'ONEY - WASHITA 138KV CKT 1'		
FDNS	7	0 11G	G09_030	TO->FROM'	'CLINTON JUNCTION - G07-32T 138.00 138KV CKT 1'		143	0.99281	120.9552	'ONEY - WASHITA 138KV CKT 1'		
FDNS	7	0 11G	G09_030	TO->FROM'	'WEATHERFORD JCT. - WEATHERFORD SOUTHEAST		210	0.37346	107.5888	'ONEY - WASHITA 138KV CKT 1'		
FDNS	7	0 11G	G09_030	FROM->TO'	'CAN_GAS4 138.00 - JENSEN ROAD 138KV CKT 1'		191	0.37346	108.3051	'ONEY - WASHITA 138KV CKT 1'		
FDNS	7	0 11G	G09_030	TO->FROM'	'SOUTHWESTERN STATION - WASHITA 138KV CKT 1'		260	0.29689	105.7635	'GRACMNT7 345.00 (BANK 1) 345/138/13.8KV TRANSFORMER C		
FDNS	7	0 11G	G09_030	TO->FROM'	'SOUTHWESTERN STATION - WASHITA 138KV CKT 1'		260	0.22396	107.3589	'BASE CASE'		
FDNS	7	0 11G	G09_030	TO->FROM'	'HYDRO - WEATHERFORD 138KV CKT 1'		179	0.53285	110.1846	'HINTON - WEATHERFORD JCT. 138KV CKT 1'		
FDNS	7	0 11G	G09_030	TO->FROM'	'HYDRO - WEATHERFORD 138KV CKT 1'		179	0.53285	109.9607	'CAN_GAS4 138.00 - HINTON 138KV CKT 1'		
FDNS	7	0 11G	G09_030	TO->FROM'	'GRACMNT4 138.00 - WASHITA 138KV CKT 1'		228	0.38784	146.7726	'SOUTHWESTERN STATION - WASHITA 138KV CKT 1'		
FDNS	7	0 11G	G09_030	TO->FROM'	'HYDRO - WEATHERFORD 138KV CKT 1'		179	0.99281	109.1505	'CLINTON JUNCTION - G07-32T 138.00 138KV CKT 1'		
FDNS	7	0 11G	G09_030	TO->FROM'	'HYDRO - WEATHERFORD 138KV CKT 1'		179	0.53285	113.1714	'WEATHERFORD JCT. - WEATHERFORD SOUTHEAST 138KV CK		
FDNS	7	0 11G	G09_030	TO->FROM'	'HYDRO - WEATHERFORD 138KV CKT 1'		179	0.49883	100.7297	'WEATHERFORD TAP - WEATHERFORD WIND FARM 138KV CKT		
FDNS	7	0 11G	G09_030	TO->FROM'	'HYDRO - WEATHERFORD 138KV CKT 1'		179	0.53285	109.1131	'CAN_GAS4 138.00 - JENSEN ROAD 138KV CKT 1'		
FDNS	7	0 11G	G09_030	TO->FROM'	'SOUTHWESTERN STATION - WASHITA 138KV CKT 1'		260	0.40085	134.8215	'GRACMNT4 138.00 - WASHITA 138KV CKT 1'		
FDNS	7	0 11G	G09_030	TO->FROM'	'HINTON - WEATHERFORD JCT. 138KV CKT 1'		210	0.37346	101.2292	'BINGER NIJECT - ONEY 138KV CKT 1'		
FDNS	7	0 11G	G09_030	TO->FROM'	'CLINTON JUNCTION - G07-32T 138.00 138KV CKT 1'		143	0.99281	122.7317	'BINGER NIJECT - ONEY 138KV CKT 1'		
FDNS	7	0 11G	G09_030	TO->FROM'	'WEATHERFORD JCT. - WEATHERFORD SOUTHEAST		210	0.37346	108.0455	'BINGER NIJECT - ONEY 138KV CKT 1'		
FDNS	7	0 11G	G09_030	FROM->TO'	'CAN_GAS4 138.00 - JENSEN ROAD 138KV CKT 1'		191	0.37346	108.8038	'BINGER NIJECT - ONEY 138KV CKT 1'		
FDNS	7	0 11G	G09_030	TO->FROM'	'HINTON - WEATHERFORD JCT. 138KV CKT 1'		210	0.37346	102.5419	'BINGER NIJECT - SICKLES 138KV CKT 1'		
FDNS	7	0 11G	G09_030	TO->FROM'	'CLINTON JUNCTION - G07-32T 138.00 138KV CKT 1'		143	0.99281	127.8357	'BINGER NIJECT - SICKLES 138KV CKT 1'		
FDNS	7	0 11G	G09_030	TO->FROM'	'WEATHERFORD JCT. - WEATHERFORD SOUTHEAST		210	0.37346	109.3683	'BINGER NIJECT - SICKLES 138KV CKT 1'		
FDNS	7	0 11G	G09_030	FROM->TO'	'CAN_GAS4 138.00 - JENSEN ROAD 138KV CKT 1'		191	0.37346	110.249	'BINGER NIJECT - SICKLES 138KV CKT 1'		
FDNS	7	0 11G	G09_030	TO->FROM'	'HINTON - WEATHERFORD JCT. 138KV CKT 1'		210	0.37346	103.837	'HYDRO - SICKLES 138KV CKT 1'		
FDNS	7	0 11G	G09_030	TO->FROM'	'CLINTON JUNCTION - G07-32T 138.00 138KV CKT 1'		143	0.99281	132.9031	'HYDRO - SICKLES 138KV CKT 1'		
FDNS	7	0 11G	G09_030	TO->FROM'	'WEATHERFORD JCT. - WEATHERFORD SOUTHEAST		210	0.37346	110.6738	'HYDRO - SICKLES 138KV CKT 1'		
FDNS	7	0 11G	G09_030	FROM->TO'	'CAN_GAS4 138.00 - JENSEN ROAD 138KV CKT 1'		191	0.37346	111.675	'HYDRO - SICKLES 138KV CKT 1'		
FDNS	7	0 11G	G09_030	FROM->TO'	'JENSEN ROAD - JENSEN TAP 138KV CKT 1'		191	0.34373	100	'HYDRO - SICKLES 138KV CKT 1'		
FDNS	7	0 11G	G09_030	TO->FROM'	'HINTON - WEATHERFORD JCT. 138KV CKT 1'		210	0.37346	104.5236	'HYDRO - WEATHERFORD 138KV CKT 1'		
FDNS	7	0 11G	G09_030	TO->FROM'	'CLINTON JUNCTION - G07-32T 138.00 138KV CKT 1'		143	0.99281	135.6347	'HYDRO - WEATHERFORD 138KV CKT 1'		
FDNS	7	0 11G	G09_030	TO->FROM'	'WEATHERFORD JCT. - WEATHERFORD SOUTHEAST		210	0.37346	111.3666	'HYDRO - WEATHERFORD 138KV CKT 1'		
FDNS	7	0 11G	G09_030	FROM->TO'	'CAN_GAS4 138.00 - JENSEN ROAD 138KV CKT 1'		191	0.37346	112.4296	'HYDRO - WEATHERFORD 138KV CKT 1'		
FDNS	7	0 11G	G09_030	FROM->TO'	'JENSEN ROAD - JENSEN TAP 138KV CKT 1'		191	0.34373	100.7002	'HYDRO - WEATHERFORD 138KV CKT 1'		
FDNS	7	0 11G	G09_030	TO->FROM'	'HINTON - WEATHERFORD JCT. 138KV CKT 1'		210	0.37346	100.7762	'ONEY - WASHITA 138KV CKT 1'		
FDNS	7	0 11G	G09_030	TO->FROM'	'CLINTON JUNCTION - G07-32T 138.00 138KV CKT 1'		143	0.99281	120.9552	'ONEY - WASHITA 138KV CKT 1'		
FDNS	7	0 11G	G09_030	TO->FROM'	'WEATHERFORD JCT. - WEATHERFORD SOUTHEAST		210	0.37346	107.5888	'ONEY - WASHITA 138KV CKT 1'		
FDNS	7	0 11G	G09_030	FROM->TO'	'CAN_GAS4 138.00 - JENSEN ROAD 138KV CKT 1'		191	0.37346	108.3051	'ONEY - WASHITA 138KV CKT 1'		
FDNS	7	0 11G	G09_030	TO->FROM'	'SOUTHWESTERN STATION - WASHITA 138KV CKT 1'		260	0.29689	105.7635	'GRACMNT7 345.00 (BANK 1) 345/138/13.8KV TRANSFORMER C		
FDNS	7	2 11G	G09_030	TO->FROM'	'SOUTHWESTERN STATION - WASHITA 138KV CKT 1'		260	0.24771	98.1	'BASE CASE'		
FDNS	7	2 11G	G09_030	TO->FROM'	'SOUTHWESTERN STATION - WASHITA 138KV CKT 1'		260	0.36576	108.5521	'GRACMNT7 345.00 (BANK 1) 345/138/13.8KV TRANSFORMER C		
FDNS	7	2 11G	G09_030	TO->FROM'	'SOUTHWESTERN STATION - WASHITA 138KV CKT 1'		260	0.24771	98.1	'BASE CASE'		
FDNS	7	2 11G	G09_030	TO->FROM'	'SOUTHWESTERN STATION - WASHITA 138KV CKT 1'		260	0.36576	108.5521	'GRACMNT7 345.00 (BANK 1) 345/138/13.8KV TRANSFORMER C		
FDNS	07G0930	0 11G	G09_030	TO->FROM'	'SOUTHWESTERN STATION - WASHITA 138KV CKT 1'		260	0.2238	109.7794	'BASE CASE'		
FDNS	07G0930	0 11G	G09_030	TO->FROM'	'HYDRO - WEATHERFORD 138KV CKT 1'		179	0.53247	116.2747	'HINTON - WEATHERFORD JCT. 138KV CKT 1'		
FDNS	07G0930	0 11G	G09_030	TO->FROM'	'HYDRO - WEATHERFORD 138KV CKT 1'		179	0.53247	116.0478	'CAN_GAS4 138.00 - HINTON 138KV CKT 1'		
FDNS	07G0930	0 11G	G09_030	TO->FROM'	'GRACMNT4 138.00 - WASHITA 138KV CKT 1'		228	0.38756	150.4651	'SOUTHWESTERN STATION - WASHITA 138KV CKT 1'		
FDNS	07G0930	0 11G	G09_030	TO->FROM'	'HYDRO - WEATHERFORD 138KV CKT 1'		179	0.99209	121.5375	'CLINTON JUNCTION - G07-32T 138.00 138KV CKT 1'		
FDNS	07G0930	0 11G	G09_030	TO->FROM'	'HYDRO - WEATHERFORD 138KV CKT 1'		179	0.53247	119.2818	'WEATHERFORD JCT. - WEATHERFORD SOUTHEAST 138KV CK		
FDNS	07G0930	0 11G	G09_030	TO->FROM'	'HYDRO - WEATHERFORD 138KV CKT 1'		179	0.49847	104.5635	'WEATHERFORD SOUTHEAST - WEATHERFORD TAP 138KV CKT		
FDNS	07G0930	0 11G	G09_030	TO->FROM'	'HYDRO - WEATHERFORD 138KV CKT 1'		179	0.49847	106.461	'WEATHERFORD TAP - WEATHERFORD WIND FARM 138KV CKT		
FDNS	07G0930	0 11G	G09_030	TO->FROM'	'HYDRO - WEATHERFORD 138KV CKT 1'		179	0.53247	115.1975	'CAN_GAS4 138.00 - JENSEN ROAD 138KV CKT 1'		
FDNS	07G0930	0 11G	G09_030	TO->FROM'	'WEATHERFORD JCT. - WEATHERFORD SOUTHEAST		210	0.22476	100.6098	'STLN-DEMARC6230.00 - SWEETWT6 230.00 230KV CKT 1'		
FDNS	07G0930	0 11G	G09_030	FROM->TO'	'CAN_GAS4 138.00 - JENSEN ROAD 138KV CKT 1'		191	0.22476	100.6238	'STLN-DEMARC6230.00 - SWEETWT6 230.00 230KV CKT 1'		
FDNS	07G0930	0 11G	G09_030	TO->FROM'	'SOUTHWESTERN STATION - WASHITA 138KV CKT 1'		260	0.40056	138.1286	'GRACMNT4 138.00 - WASHITA 138KV CKT 1'		
FDNS	07G0930	0 11G	G09_030	TO->FROM'	'HINTON - WEATHERFORD JCT. 138KV CKT 1'		210	0.37319	104.749	'BINGER NIJECT - ONEY 138KV CKT 1'		
FDNS	07G0930	0 11G	G09_030	TO->FROM'	'CLINTON JUNCTION - G07-32T 138.00 138KV CKT 1'		143	0.99209	136.6514	'BINGER NIJECT - ONEY 138KV CKT 1'		
FDNS	07G0930	0 11G	G09_030	TO->FROM'	'WEATHERFORD JCT. - WEATHERFORD SOUTHEAST		210	0.37319	111.5947	'BINGER NIJECT - ONEY 138KV CKT 1'		
FDNS	07G0930	0 11G	G09_030	FROM->TO'	'CAN_GAS4 138.00 - JENSEN ROAD 138KV CKT 1'		191	0.37319	112.6769	'BINGER NIJECT - ONEY 138KV CKT 1'		

SOLUTION GROUP	SCENARI	SEASON	SOURCE	DIRECTION	MONITORED ELEMENT COMMON NAME	RATEB	TDF	TC%	LOAD CONTINGENCY NAME
FDNS	07G0930	0 11G	G09_030	'FROM->TO'	'CAN_GAS4 138.00 - JENSEN ROAD 138KV CKT 1'	191	0.22476	100.6238	'SPP-SWPS-02'
FDNS	07G0930	2 11G	G09_030	'TO->FROM'	'SOUTHWESTERN STATION - WASHITA 138KV CKT 1'	260	0.24753	100.7888	'BASE CASE'
FDNS	07G0930	2 11G	G09_030	'TO->FROM'	'SOUTHWESTERN STATION - WASHITA 138KV CKT 1'	260	0.36548	111.5958	'GRACMNT7 345.00 (BANK 1) 345/138/13.8KV TRANSFORMER C
FDNS	07G0930	2 11G	G09_030	'TO->FROM'	'SOUTHWESTERN STATION - WASHITA 138KV CKT 1'	260	0.24753	100.7888	'BASE CASE'
FDNS	07G0930	2 11G	G09_030	'TO->FROM'	'SOUTHWESTERN STATION - WASHITA 138KV CKT 1'	260	0.36548	111.5958	'GRACMNT7 345.00 (BANK 1) 345/138/13.8KV TRANSFORMER C
FNSL-Itera 02ALL		0 11G	G09_030		Non Converged	0	0.17126	9999	'SPP-SWPS-03'
FNSL-Itera 02ALL		0 11G	G09_030		Non Converged	1052	0.13545	97.33807	'FINNEY SWITCHING STATION - STEVENSCO 345.00 345KV CK'
FNSL-Itera 02ALL		0 11G	G09_030		Non Converged	0	0.11965	9999	'DBL-G0847-WO'
FNSL-Itera 02ALL		0 11G	G09_030		Non Converged	351	0.09752	81.98898	'GRAPEVINE INTERCHANGE - NICHOLS STATION 230KV CKT 1'
FNSL-Itera 02ALL		0 11G	G09_030		Non Converged	0	0.08064	9999	'ATC_B2_8E2_G'
FNSL-Itera 02ALL		0 11G	G09_030		Non Converged	0	0.0783	9999	'050 1'
FNSL-Itera 02ALL		0 11G	G09_030		Non Converged	0	0.07558	9999	'ATC_B2_8E2'
FNSL-Itera 02ALL		0 11G	G09_030		Non Converged	0	0.07529	9999	'ATC_B2_8E2'
FNSL-Itera 02ALL		0 11G	G09_030		Non Converged	0	0.07377	9999	'050 2'
FNSL-Itera 02ALL		0 11G	G09_030		Non Converged	351	0.06434	81.98898	'GRAPEVINE INTERCHANGE - NICHOLS STATION 230KV CKT 1'
FNSL-Blow 02ALL		0 11G	G09_030		Non Converged	72	0.05334	41.71536	'ALTUS JCT TAP - RUSSELL 138KV CKT 1'
FNSL-Itera 02ALL		0 11G	G09_030		Non Converged	0	0.05106	9999	'ATC_B2_8E2'
FNSL-Itera 02ALL		0 11G	G09_030		Non Converged	0	0.04962	9999	'050 2'
FNSL-Itera 02ALL		0 11G	G09_030		Non Converged	441	0.04144	56.55862	'STLN-DEMARC6230.00 - SWEETWT6 230.00 230KV CKT 1'
FNSL-Itera 02ALL		0 11G	G09_030		Non Converged	0	0.03146	9999	'ATC_B2_8E2_G'
FNSL-Itera 02ALL		0 11G	G09_030		Non Converged	0	0.02986	9999	'050 1'
FNSL-Itera 02ALL		0 11G	G09_030		Non Converged	0	0.02783	9999	'050 2'
FNSL-Itera 02ALL		0 11G	G09_030		Non Converged	0	0.02348	9999	'ATC_B2_8E2_G'
FNSL-Itera 02ALL		0 11G	G09_030		Non Converged	0	0.02244	9999	'050 1'
FNSL-Itera 02ALL		0 11G	G09_030		Non Converged	441	0.022	57.29366	'STLN-DEMARC6230.00 - SWEETWT6 230.00 230KV CKT 1'
FNSL-Itera 00G09_04(0 11WP	G09_040		Non Converged	245	0.56653	7.812411	'KELLY - SOUTH SENECA 115KV CKT 1'
FNSL-Itera 00G09_04(0 11WP	G09_040		Non Converged	245	0.56653	7.812411	'KELLY - SOUTH SENECA 115KV CKT 1'
FNSL-Itera 02ALL		0 11G	G09_040		Non Converged	0	0.14045	9999	'SPP-SWPS-02'
FNSL-Itera 02ALL		0 11G	G09_040		Non Converged	0	0.12296	9999	'DBL-G0847-WO'
FNSL-Itera 02ALL		0 11G	G09_040		Non Converged	441	0.10562	56.87944	'STATELINE INTERCHANGE - STLN-DEMARC6230.00 230KV CKT
FNSL-Itera 02ALL		0 11G	G09_040		Non Converged	0	0.08072	9999	'ATC_B2_8E2_G'
FNSL-Itera 02ALL		0 11G	G09_040		Non Converged	0	0.07832	9999	'050 1'
FNSL-Itera 02ALL		0 11G	G09_040		Non Converged	0	0.07818	9999	'050 1'
FNSL-Itera 02ALL		0 11G	G09_040		Non Converged	0	0.07546	9999	'ATC_B2_8E2'
FNSL-Itera 02ALL		0 11G	G09_040		Non Converged	0	0.07379	9999	'050 2'
FNSL-Itera 02ALL		0 11G	G09_040		Non Converged	441	0.07011	57.61415	'STATELINE INTERCHANGE - STLN-DEMARC6230.00 230KV CKT
FNSL-Itera 02ALL		0 11G	G09_040		Non Converged	0	0.0548	9999	'ATC_B2_8E2_G'
FNSL-Blow 02ALL		0 11G	G09_040		Non Converged	0	0.05249	9999	'SPP-SWPS-03'
FNSL-Itera 02ALL		0 11G	G09_040		Non Converged	0	0.04964	9999	'050 2'
FNSL-Itera 02ALL		0 11G	G09_040		Non Converged	0	0.04172	9999	'DBL-G0847-WO'
FNSL-Itera 02ALL		0 11G	G09_040		Non Converged	0	0.03155	9999	'ATC_B2_8E2_G'
FNSL-Itera 02ALL		0 11G	G09_040		Non Converged	0	0.03001	9999	'050 1'
FNSL-Itera 02ALL		0 11G	G09_040		Non Converged	0	0.02793	9999	'050 2'
FNSL-Itera 02ALL		0 11G	G09_040		Non Converged	0	0.02544	9999	'SPP-SWPS-03'
FNSL-Itera 02ALL		0 11G	G09_040		Non Converged	0	0.02262	9999	'050 1'
FNSL-Itera 02ALL		0 11G	G09_040		Non Converged	441	0.02205	56.87944	'STATELINE INTERCHANGE - STLN-DEMARC6230.00 230KV CKT
FNSL-Itera 00G09_04(0 11WP	G09_040		Non Converged	245	0.56653	7.812411	'KELLY - SOUTH SENECA 115KV CKT 1'
FNSL-Itera 00G09_04(0 11WP	G09_040		Non Converged	0	0.03189	9999	'ATC_B2_8E2_G'
FNSL-Itera 0		0 11WP	G09_040		Non Converged	0	0.03196	9999	'ATC_B2_8E2_G'
FNSL-Itera 1		0 11G	G09_040		Non Converged	0	0.03057	9999	'050 1'
FNSL-Itera 1		0 11G	G09_040		Non Converged	0	0.03202	9999	'ATC_B2_8E2_G'
FNSL-Itera 1		2 11G	G09_040		Non Converged	0	0.03059	9999	'050 1'
FNSL-Itera 1		2 11G	G09_040		Non Converged	0	0.03204	9999	'ATC_B2_8E2_G'
FNSL-Itera 02ALL		0 11G	G09_040		Non Converged	0	0.03121	9999	'ATC_B2_8E2_G'
FNSL-Itera 02ALL		2 11G	G09_040		Non Converged	0	0.03129	9999	'ATC_B2_8E2_G'
FNSL-Itera 02ALL		3 11G	G09_040		Non Converged	0	0.03143	9999	'ATC_B2_8E2_G'
FNSL-Itera 02G08110		0 11G	G09_040		Non Converged	0	0.03141	9999	'ATC_B2_8E2_G'
FNSL-Itera 02G08110		2 11G	G09_040		Non Converged	0	0.03003	9999	'050 1'
FNSL-Itera 02G08110		2 11G	G09_040		Non Converged	0	0.03147	9999	'ATC_B2_8E2_G'
FNSL-Itera 02G08110		3 11G	G09_040		Non Converged	0	0.03012	9999	'050 1'
FNSL-Itera 02G08110		3 11G	G09_040		Non Converged	0	0.03155	9999	'ATC_B2_8E2_G'
FNSL-Itera 02G0847		0 11G	G09_040		Non Converged	0	0.03138	9999	'ATC_B2_8E2_G'
FNSL-Itera 02G0847		2 11G	G09_040		Non Converged	0	0.03144	9999	'ATC_B2_8E2_G'
FNSL-Itera 02G0847		3 11G	G09_040		Non Converged	0	0.0301	9999	'050 1'
FNSL-Itera 02G0847		3 11G	G09_040		Non Converged	0	0.03153	9999	'ATC_B2_8E2_G'
FNSL-Itera 02G1007		0 11G	G09_040		Non Converged	0	0.0314	9999	'ATC_B2_8E2_G'
FNSL-Itera 02G1007		2 11G	G09_040		Non Converged	0	0.03002	9999	'050 1'

SOLUTION GROUP	SCENARI	SEASON	SOURCE	DIRECTION	MONITORED ELEMENT	COMMON NAME	RATEB	TDF	TC%	LOAD	CONTINGENCY	NAME
FNSL-Itera 02G1007		2	11G		G09_040	Non Converged	0	0.03146	9999	'ATC_B2_8E2_G'		
FNSL-Itera 02G1007		3	11G		G09_040	Non Converged	0	0.03011	9999	'050 1'		
FNSL-Itera 02G1007		3	11G		G09_040	Non Converged	0	0.03155	9999	'ATC_B2_8E2_G'		
FNSL-Itera 02G1014		0	11G		G09_040	Non Converged	0	0.03139	9999	'ATC_B2_8E2_G'		
FNSL-Itera 02G1014		2	11G		G09_040	Non Converged	0	0.03001	9999	'050 1'		
FNSL-Itera 02G1014		2	11G		G09_040	Non Converged	0	0.03144	9999	'ATC_B2_8E2_G'		
FNSL-Itera 02G1014		3	11G		G09_040	Non Converged	0	0.03011	9999	'050 1'		
FNSL-Itera 02G1014		3	11G		G09_040	Non Converged	0	0.03154	9999	'ATC_B2_8E2_G'		
FNSL-Itera 2		0	11G		G09_040	Non Converged	0	0.03141	9999	'ATC_B2_8E2_G'		
FNSL-Itera 2		2	11G		G09_040	Non Converged	0	0.03002	9999	'050 1'		
FNSL-Itera 2		2	11G		G09_040	Non Converged	0	0.03146	9999	'ATC_B2_8E2_G'		
FNSL-Itera 2		3	11G		G09_040	Non Converged	0	0.03011	9999	'050 1'		
FNSL-Itera 2		3	11G		G09_040	Non Converged	0	0.03155	9999	'ATC_B2_8E2_G'		
FNSL-Itera 03ALL		0	11G		G09_040	Non Converged	0	0.03037	9999	'ATC_B2_8E2_G'		
FNSL-Itera 3		0	11G		G09_040	Non Converged	0	0.03088	9999	'ATC_B2_8E2_G'		
FNSL-Itera 3		2	11G		G09_040	Non Converged	0	0.03088	9999	'ATC_B2_8E2_G'		
FNSL-Itera 5		0	11G		G09_040	Non Converged	0	0.03046	9999	'050 1'		
FNSL-Itera 5		0	11G		G09_040	Non Converged	0	0.03191	9999	'ATC_B2_8E2_G'		
FNSL-Itera 6		0	11G		G09_040	Non Converged	0	0.03062	9999	'050 1'		
FNSL-Itera 6		0	11G		G09_040	Non Converged	0	0.03207	9999	'ATC_B2_8E2_G'		
FNSL-Itera 7		0	11G		G09_040	Non Converged	0	0.03084	9999	'050 1'		
FNSL-Itera 7		0	11G		G09_040	Non Converged	0	0.03231	9999	'ATC_B2_8E2_G'		
FNSL-Itera 7		2	11G		G09_040	Non Converged	0	0.03085	9999	'050 1'		
FNSL-Itera 7		2	11G		G09_040	Non Converged	0	0.03231	9999	'ATC_B2_8E2_G'		
FNSL-Itera 8		0	11G		G09_040	Non Converged	0	0.03068	9999	'050 1'		
FNSL-Itera 8		0	11G		G09_040	Non Converged	0	0.03213	9999	'ATC_B2_8E2_G'		
FNSL-Itera 9		0	11G		G09_040	Non Converged	0	0.03068	9999	'ATC_B2_8E2_G'		
FNSL-Itera 9		2	11G		G09_040	Non Converged	0	0.03068	9999	'ATC_B2_8E2_G'		
FNSL-Itera 11		0	11G		G09_040	Non Converged	0	0.03017	9999	'050 1'		
FNSL-Itera 11		0	11G		G09_040	Non Converged	0	0.03161	9999	'ATC_B2_8E2_G'		
FNSL-Itera 11		2	11G		G09_040	Non Converged	0	0.03017	9999	'050 1'		
FNSL-Itera 11		2	11G		G09_040	Non Converged	0	0.03161	9999	'ATC_B2_8E2_G'		
FNSL-Itera 13G0940		0	11G		G09_040	Non Converged	0	0.03132	9999	'ATC_B2_8E2_G'		
FNSL-Itera 13		0	11G		G09_040	Non Converged	0	0.03134	9999	'ATC_B2_8E2_G'		
FNSL-Itera 14		0	11G		G09_040	Non Converged	0	0.03073	9999	'050 1'		
FNSL-Itera 14		0	11G		G09_040	Non Converged	0	0.03219	9999	'ATC_B2_8E2_G'		
FNSL-Itera 15		0	11G		G09_040	Non Converged	0	0.03058	9999	'050 1'		
FNSL-Itera 15		0	11G		G09_040	Non Converged	0	0.03203	9999	'ATC_B2_8E2_G'		
FDNS 3		0	11G		G09_059	'TO->FROM'	129.5	0.20599	104.2441	'PIONEER TAP - PLYMELL 115KV CKT 1'		
FDNS 3		0	11G		G09_059	'FROM->TO'	129.5	0.20599	101.2499	'HOLCOMB - PLYMELL 115KV CKT 1'		
FDNS 3		0	11G		G09_059	'TO->FROM'	129.5	0.20599	106.2909	'HOLCOMB - PLYMELL 115KV CKT 1'		
FDNS 3		0	11G		G09_059	'TO->FROM'	89.6	0.25407	107.2374	'CIMARRON RIVER TAP - EAST LIBERAL 115KV CKT 1'		
FDNS 3		0	11G		G09_059	'TO->FROM'	129.5	0.99425	119.5326	'G08-79T 115.00 - JUDSON LARGE 115KV CKT 1'		
FDNS 3		0	11G		G09_059	'FROM->TO'	129.5	0.99425	120.9977	'G08-79T 115.00 - JUDSON LARGE 115KV CKT 1'		
FDNS 3		0	11G		G09_059	'TO->FROM'	89.6	0.83885	112.791	'G08-79T 115.00 - JUDSON LARGE 115KV CKT 1'		
FDNS 3		0	11G		G09_059	'TO->FROM'	129.5	0.99425	126.0295	'G08-79T 115.00 - JUDSON LARGE 115KV CKT 1'		
FDNS 3		0	11G		G09_059	'TO->FROM'	129.5	0.20599	104.181	'SPP-SUNC-14'		
FDNS 3		0	11G		G09_059	'TO->FROM'	129.5	0.25552	100.2348	'GEN531447 1-HOLCOMB GENERATOR'		
FNSL 3		0	11G		G09_059	'FROM->TO'	129.5	0.99425	125.0886	'CUDAHY - G09-59T 115.00 115KV CKT 1'		
FNSL 3		0	11G		G09_059	'FROM->TO'	177.7	0.57949	104.6461	'NORTH JUDSON LARGE SUB - SPEARVILLE 115KV CKT 1'		
FNSL 3		0	11G		G09_059	'FROM->TO'	177.7	0.57949	104.6461	'NORTH JUDSON LARGE SUB - SPEARVILLE 115KV CKT 2'		
FDNS 3		0	11G		G09_059	'TO->FROM'	129.5	0.20599	104.2441	'PIONEER TAP - PLYMELL 115KV CKT 1'		
FDNS 3		0	11G		G09_059	'FROM->TO'	129.5	0.20599	101.2499	'HOLCOMB - PLYMELL 115KV CKT 1'		
FDNS 3		0	11G		G09_059	'TO->FROM'	129.5	0.20599	106.2909	'HOLCOMB - PLYMELL 115KV CKT 1'		
FDNS 3		0	11G		G09_059	'TO->FROM'	89.6	0.25407	107.2374	'CIMARRON RIVER TAP - EAST LIBERAL 115KV CKT 1'		
FDNS 3		0	11G		G09_059	'TO->FROM'	129.5	0.99425	119.5326	'G08-79T 115.00 - JUDSON LARGE 115KV CKT 1'		
FDNS 3		0	11G		G09_059	'FROM->TO'	129.5	0.99425	120.9977	'G08-79T 115.00 - JUDSON LARGE 115KV CKT 1'		
FDNS 3		0	11G		G09_059	'TO->FROM'	89.6	0.83885	112.791	'G08-79T 115.00 - JUDSON LARGE 115KV CKT 1'		
FDNS 3		0	11G		G09_059	'TO->FROM'	129.5	0.99425	126.0295	'G08-79T 115.00 - JUDSON LARGE 115KV CKT 1'		
FDNS 3		0	11G		G09_059	'TO->FROM'	129.5	0.20599	104.181	'SPP-SUNC-14'		
FNSL 3		0	11G		G09_059	'FROM->TO'	129.5	0.25552	100.2348	'GEN531447 1-HOLCOMB GENERATOR'		
FNSL 3		0	11G		G09_059	'FROM->TO'	129.5	0.99425	125.0886	'CUDAHY - G09-59T 115.00 115KV CKT 1'		
FNSL 3		0	11G		G09_059	'FROM->TO'	177.7	0.57949	104.6461	'NORTH JUDSON LARGE SUB - SPEARVILLE 115KV CKT 1'		
FNSL 3		0	11G		G09_059	'FROM->TO'	177.7	0.57949	104.6461	'NORTH JUDSON LARGE SUB - SPEARVILLE 115KV CKT 2'		
FDNS 03G0959		0	11G		G09_059	'TO->FROM'	129.5	0.20584	101.2535	'PIONEER TAP - PLYMELL 115KV CKT 1'		
FDNS 03G0959		0	11G		G09_059	'FROM->TO'	129.5	0.20584	102.7134	'PIONEER TAP - PLYMELL 115KV CKT 1'		
FDNS 03G0959		0	11G		G09_059	'TO->FROM'	129.5	0.20584	107.7165	'PIONEER TAP - PLYMELL 115KV CKT 1'		

SOLUTION GROUP	SCENARIO	SEASON	SOURCE	DIRECTION	MONITORED ELEMENT	COMMON NAME	RATEB	TDF	TC%	LOAD	CONTINGENCY	NAME
FDNS	03G0959	0 11G	G09_059	TO->FROM	'CIMARRON RIVER TAP - KISMET 3	115.00 115KV CK	129.5	0.20584	103.3623	'HOLCOMB - PLYMELL 115KV CKT 1'		
FDNS	03G0959	0 11G	G09_059	FROM->TO	'CUDAHY - KISMET 3	115.00 115KV CKT 1'	129.5	0.20584	104.8068	'HOLCOMB - PLYMELL 115KV CKT 1'		
FDNS	03G0959	0 11G	G09_059	TO->FROM	'CUDAHY - G09-59T	115.00 115KV CKT 1'	129.5	0.20584	109.8175	'HOLCOMB - PLYMELL 115KV CKT 1'		
FDNS	03G0959	0 11G	G09_059	TO->FROM	'CIMARRON RIVER PLANT - CIMARRON RIVER TAP 11		89.6	0.25388	113.4118	'CIMARRON RIVER TAP - EAST LIBERAL 115KV CKT 1'		
FDNS	03G0959	0 11G	G09_059	TO->FROM	'CIMARRON RIVER TAP - KISMET 3	115.00 115KV CK	129.5	0.99354	135.924	'G08-79T 115.00 - JUDSON LARGE 115KV CKT 1'		
FDNS	03G0959	0 11G	G09_059	FROM->TO	'CUDAHY - KISMET 3	115.00 115KV CKT 1'	129.5	0.99354	137.3933	'G08-79T 115.00 - JUDSON LARGE 115KV CKT 1'		
FDNS	03G0959	0 11G	G09_059	TO->FROM	'CIMARRON RIVER PLANT - CIMARRON RIVER TAP 11		89.6	0.83825	131.962	'G08-79T 115.00 - JUDSON LARGE 115KV CKT 1'		
FDNS	03G0959	0 11G	G09_059	TO->FROM	'CUDAHY - G09-59T	115.00 115KV CKT 1'	129.5	0.99354	142.5175	'G08-79T 115.00 - JUDSON LARGE 115KV CKT 1'		
FDNS	03G0959	0 11G	G09_059	TO->FROM	'CUDAHY - G09-59T	115.00 115KV CKT 1'	129.5	0.26036	104.2113	'DBL-SPRVL-CO'		
FDNS	03G0959	0 11G	G09_059	TO->FROM	'CUDAHY - G09-59T	115.00 115KV CKT 1'	129.5	0.26036	104.0042	'DBL-COM-MEDL'		
FDNS	03G0959	0 11G	G09_059	TO->FROM	'CIMARRON RIVER TAP - KISMET 3	115.00 115KV CK	129.5	0.20584	101.2156	'SPP-SUNC-14'		
FDNS	03G0959	0 11G	G09_059	FROM->TO	'CUDAHY - KISMET 3	115.00 115KV CKT 1'	129.5	0.20584	102.6862	'SPP-SUNC-14'		
FDNS	03G0959	0 11G	G09_059	TO->FROM	'CUDAHY - G09-59T	115.00 115KV CKT 1'	129.5	0.20584	107.7095	'SPP-SUNC-14'		
FDNS	03G0959	0 11G	G09_059	TO->FROM	'CUDAHY - G09-59T	115.00 115KV CKT 1'	129.5	0.25533	104.4891	'GEN531447 1-HOLCOMB GENERATOR'		
FNSL	03G0959	0 11G	G09_059	FROM->TO	'G08-79T 115.00 - JUDSON LARGE 115KV CKT 1'		129.5	0.99354	140.5801	'CUDAHY - G09-59T 115.00 115KV CKT 1'		
FNSL	03G0959	0 11G	G09_059	FROM->TO	'NORTH JUDSON LARGE SUB - SPEARVILLE 115KV CI		177.7	0.57901	112.4083	'NORTH JUDSON LARGE SUB - SPEARVILLE 115KV CKT 1'		
FNSL	03G0959	0 11G	G09_059	FROM->TO	'NORTH JUDSON LARGE SUB - SPEARVILLE 115KV CI		177.7	0.57901	112.4083	'NORTH JUDSON LARGE SUB - SPEARVILLE 115KV CKT 2'		
FDNS	03G0959	0 11G	G09_059	TO->FROM	'CIMARRON RIVER TAP - KISMET 3	115.00 115KV CK	129.5	0.20584	101.2535	'PIONEER TAP - PLYMELL 115KV CKT 1'		
FDNS	03G0959	0 11G	G09_059	FROM->TO	'CUDAHY - KISMET 3	115.00 115KV CKT 1'	129.5	0.20584	102.7134	'PIONEER TAP - PLYMELL 115KV CKT 1'		
FDNS	03G0959	0 11G	G09_059	TO->FROM	'CUDAHY - G09-59T	115.00 115KV CKT 1'	129.5	0.20584	107.7165	'PIONEER TAP - PLYMELL 115KV CKT 1'		
FDNS	03G0959	0 11G	G09_059	TO->FROM	'CIMARRON RIVER TAP - KISMET 3	115.00 115KV CK	129.5	0.20584	103.3623	'HOLCOMB - PLYMELL 115KV CKT 1'		
FDNS	03G0959	0 11G	G09_059	FROM->TO	'CUDAHY - KISMET 3	115.00 115KV CKT 1'	129.5	0.20584	104.8068	'HOLCOMB - PLYMELL 115KV CKT 1'		
FDNS	03G0959	0 11G	G09_059	TO->FROM	'CUDAHY - G09-59T	115.00 115KV CKT 1'	129.5	0.20584	109.8175	'HOLCOMB - PLYMELL 115KV CKT 1'		
FDNS	03G0959	0 11G	G09_059	TO->FROM	'CIMARRON RIVER PLANT - CIMARRON RIVER TAP 11		89.6	0.25388	113.4118	'CIMARRON RIVER TAP - EAST LIBERAL 115KV CKT 1'		
FDNS	03G0959	0 11G	G09_059	TO->FROM	'CIMARRON RIVER TAP - KISMET 3	115.00 115KV CK	129.5	0.99354	135.924	'G08-79T 115.00 - JUDSON LARGE 115KV CKT 1'		
FDNS	03G0959	0 11G	G09_059	FROM->TO	'CUDAHY - KISMET 3	115.00 115KV CKT 1'	129.5	0.99354	137.3933	'G08-79T 115.00 - JUDSON LARGE 115KV CKT 1'		
FDNS	03G0959	0 11G	G09_059	TO->FROM	'CIMARRON RIVER PLANT - CIMARRON RIVER TAP 11		89.6	0.83825	131.962	'G08-79T 115.00 - JUDSON LARGE 115KV CKT 1'		
FDNS	03G0959	0 11G	G09_059	FROM->TO	'CUDAHY - KISMET 3	115.00 115KV CKT 1'	129.5	0.99354	142.5175	'G08-79T 115.00 - JUDSON LARGE 115KV CKT 1'		
FDNS	03G0959	0 11G	G09_059	TO->FROM	'CUDAHY - G09-59T	115.00 115KV CKT 1'	129.5	0.26036	104.2113	'DBL-SPRVL-CO'		
FDNS	03G0959	0 11G	G09_059	TO->FROM	'CUDAHY - G09-59T	115.00 115KV CKT 1'	129.5	0.26036	104.0042	'DBL-COM-MEDL'		
FDNS	03G0959	0 11G	G09_059	TO->FROM	'CIMARRON RIVER TAP - KISMET 3	115.00 115KV CK	129.5	0.20584	101.2156	'SPP-SUNC-14'		
FDNS	03G0959	0 11G	G09_059	FROM->TO	'CUDAHY - KISMET 3	115.00 115KV CKT 1'	129.5	0.20584	102.6862	'SPP-SUNC-14'		
FDNS	03G0959	0 11G	G09_059	TO->FROM	'CUDAHY - G09-59T	115.00 115KV CKT 1'	129.5	0.25533	104.4891	'GEN531447 1-HOLCOMB GENERATOR'		
FNSL	03G0959	0 11G	G09_059	FROM->TO	'G08-79T 115.00 - JUDSON LARGE 115KV CKT 1'		129.5	0.99354	140.5801	'CUDAHY - G09-59T 115.00 115KV CKT 1'		
FNSL	03G0959	0 11G	G09_059	FROM->TO	'NORTH JUDSON LARGE SUB - SPEARVILLE 115KV CI		177.7	0.57901	112.4083	'NORTH JUDSON LARGE SUB - SPEARVILLE 115KV CKT 1'		
FNSL	03G0959	0 11G	G09_059	FROM->TO	'NORTH JUDSON LARGE SUB - SPEARVILLE 115KV CI		177.7	0.57901	112.4083	'NORTH JUDSON LARGE SUB - SPEARVILLE 115KV CKT 2'		
FDNS	03G0959	2 11G	G09_059	TO->FROM	'CUDAHY - G09-59T	115.00 115KV CKT 1'	129.5	0.19839	97.9	'DBL-SPRVL-CO'		
FDNS	03G0959	2 11G	G09_059	TO->FROM	'CUDAHY - G09-59T	115.00 115KV CKT 1'	129.5	0.19839	97.6	'DBL-COM-MEDL'		
FDNS	03G0959	2 11G	G09_059	TO->FROM	'CUDAHY - G09-59T	115.00 115KV CKT 1'	129.5	0.1918	97.7	'GEN531447 1-HOLCOMB GENERATOR'		
FNSL	03G0959	2 11G	G09_059	FROM->TO	'SPEARVILLE (SPEARVL6) 230/115/13.8KV TRANSFOR		205	0.63589	97.1	'SPEARVILLE (SPEARVLX) 345/115/13.8KV TRANSFORMER CKT 1'		
FNSL	03G0959	2 11G	G09_059	FROM->TO	'SPEARVILLE (SPEARVL6) 230/115/13.8KV TRANSFOR		205	0.63589	97.7	'SPEARVILLE (SPEARVLX) 345/115/13.8KV TRANSFORMER CKT 1'		
FDNS	03G0959	2 11G	G09_059	TO->FROM	'CUDAHY - G09-59T	115.00 115KV CKT 1'	129.5	0.19839	97.9	'DBL-SPRVL-CO'		
FDNS	03G0959	2 11G	G09_059	TO->FROM	'CUDAHY - G09-59T	115.00 115KV CKT 1'	129.5	0.19839	97.6	'DBL-COM-MEDL'		
FDNS	03G0959	2 11G	G09_059	TO->FROM	'CUDAHY - G09-59T	115.00 115KV CKT 1'	129.5	0.1918	97.7	'GEN531447 1-HOLCOMB GENERATOR'		
FNSL	03G0959	2 11G	G09_059	FROM->TO	'SPEARVILLE (SPEARVL6) 230/115/13.8KV TRANSFOR		205	0.63589	97.1	'SPEARVILLE (SPEARVLX) 345/115/13.8KV TRANSFORMER CKT 1'		
FNSL	03G0959	2 11G	G09_059	FROM->TO	'SPEARVILLE (SPEARVL6) 230/115/13.8KV TRANSFOR		205	0.63589	97.7	'SPEARVILLE (SPEARVLX) 345/115/13.8KV TRANSFORMER CKT 1'		
FDNS	02ALL	0 11G	G09_059	FROM->TO	'FINNEY SWITCHING STATION - STEVENSCO	345.00	1052	0.21464	97.7	'HOLCOMB 115/22.0KV TRANSFORMER CKT 1'		
FNSL-Itera 02ALL	0 11G	G09_059		Non Converged			1052	0.15262	82.65054	'FINNEY SWITCHING STATION - STEVENSCO 345.00 345KV CKT 1'		
FNSL-Itera 02ALL	0 11G	G09_059		Non Converged			0	0.12763	9999	'DBL-HIT-G084'		
FNSL-Itera 02ALL	0 11G	G09_059		Non Converged			441	0.11746	56.87944	'STATELINE INTERCHANGE - STLN-DEMARC6230.00 230KV CKT 1'		
FNSL-Itera 02ALL	0 11G	G09_059		Non Converged			0	0.083	9999	'SPP-SWPS-02'		
FNSL-Itera 02ALL	0 11G	G09_059		Non Converged			0	0.08062	9999	'ATC_B2_8E2_G'		
FNSL-Itera 02ALL	0 11G	G09_059		Non Converged			0	0.07823	9999	'050 1'		
FNSL-Itera 02ALL	0 11G	G09_059		Non Converged			0	0.07551	9999	'ATC_B2_8E2'		
FNSL-Itera 02ALL	0 11G	G09_059		Non Converged			0	0.07389	9999	'050 2'		
FNSL-Itera 02ALL	0 11G	G09_059		Non Converged			441	0.07152	56.03129	'STLN-DEMARC6230.00 - SWEETWT6 230.00 230KV CKT 1'		
FNSL-Itera 02ALL	0 11G	G09_059		Non Converged			441	0.06334	57.61415	'STATELINE INTERCHANGE - STLN-DEMARC6230.00 230KV CKT 1'		
FNSL-Blow 02ALL	0 11G	G09_059		Non Converged			0	0.05291	9999	'050 1'		
FNSL-Itera 02ALL	0 11G	G09_059		Non Converged			0	0.05104	9999	'ATC_B2_8E2'		
FNSL-Itera 02ALL	0 11G	G09_059		Non Converged			0	0.04485	9999	'SPP-SWPS-T53'		
FNSL-Itera 02ALL	0 11G	G09_059		Non Converged			441	0.04139	57.61415	'STATELINE INTERCHANGE - STLN-DEMARC6230.00 230KV CKT 1'		
FNSL-Itera 02ALL	0 11G	G09_059		Non Converged			0	0.03139	9999	'ATC_B2_8E2_G'		
FNSL-Itera 02ALL	0 11G	G09_059		Non Converged			0	0.02903	9999	'ATC_B2_8E2'		
FNSL-Itera 02ALL	0 11G	G09_059		Non Converged			0	0.02778	9999	'050 2'		
FNSL-Itera 02ALL	0 11G	G09_059		Non Converged			0	0.02344	9999	'ATC_B2_8E2_G'		
FNSL-Itera 02ALL	0 11G	G09_059		Non Converged			0	0.02217	9999	'ATC_B2_8E2_G'		

SOLUTION GROUP	SCENARI	SEASON	SOURCE	DIRECTION	MONITORED ELEMENT	COMMON NAME	RATEB	TDF	TC%	LOAD	CONTINGENCY	NAME
FNSL-Itera 02ALL		0 11G	G09_059		Non Converged		0	0.02195	9999	'ATC_B2_8E2_G'		
FNSL-Itera 00G09_059		0 11WP	G09_059		Non Converged		0	0.03086	9999	'TRF-STEGALL'		
FNSL-Blow 00G09_059		0 16SP	G09_059		Non Converged		0	0.03356	9999	'TRF-STEGALL'		
FNSL-Itera 00G09_059		0 16WP	G09_059		Non Converged		0	0.03173	9999	'TRF-STEGALL'		
FNSL-Blow 0		0 16SP	G09_059		Non Converged		0	0.03362	9999	'TRF-STEGALL'		
FNSL-Itera 0		0 11WP	G09_059		Non Converged		0	0.03097	9999	'TRF-STEGALL'		
FNSL-Blow 0		0 16WP	G09_059		Non Converged		0	0.03184	9999	'TRF-STEGALL'		
FNSL-Itera 1		0 11G	G09_059		Non Converged		0	0.03152	9999	'TRF-STEGALL'		
FNSL-Itera 1		2 11G	G09_059		Non Converged		0	0.03109	9999	'TRF-STEGALL'		
FNSL-Blow 03ALL		0 11G	G09_059		Non Converged		0	0.32372	9999	'DBL-SPRVL-CO'		
FNSL-Blow 03ALL		0 11G	G09_059		Non Converged		0	0.32372	9999	'DBL-COM-MEDL'		
FNSL-Blow 03ALL		0 11G	G09_059		Non Converged		0	0.22538	9999	'DBL-MEDLO-WI'		
FNSL-Itera 5		0 11G	G09_059		Non Converged		0	0.03146	9999	'TRF-STEGALL'		
FNSL-Itera 6		0 11G	G09_059		Non Converged		0	0.03183	9999	'TRF-STEGALL'		
FNSL-Itera 7		0 11G	G09_059		Non Converged		0	0.03202	9999	'TRF-STEGALL'		
FNSL-Itera 7		2 11G	G09_059		Non Converged		0	0.03202	9999	'TRF-STEGALL'		
FNSL-Itera 8		0 11G	G09_059		Non Converged		0	0.03222	9999	'TRF-STEGALL'		
FNSL-Itera 9		0 11G	G09_059		Non Converged		0	0.03314	9999	'TRF-STEGALL'		
FNSL-Itera 9		2 11G	G09_059		Non Converged		0	0.03314	9999	'TRF-STEGALL'		
FNSL-Itera 11		0 11G	G09_059		Non Converged		0	0.03165	9999	'TRF-STEGALL'		
FNSL-Itera 11		2 11G	G09_059		Non Converged		0	0.03165	9999	'TRF-STEGALL'		
FNSL-Itera 13		0 11G	G09_059		Non Converged		0	0.03267	9999	'TRF-STEGALL'		
FNSL-Itera 14		0 11G	G09_059		Non Converged		0	0.03228	9999	'TRF-STEGALL'		
FNSL-Itera 15		0 11G	G09_059		Non Converged		0	0.03223	9999	'TRF-STEGALL'		
FDNS 7		0 11G	G09_060	'TO->FROM'	'SOUTHWESTERN STATION - WASHITA 138KV	CKT 1'	260	0.19083	134.8215	'GRACMNT4 138.00 - WASHITA 138KV	CKT 1'	
FDNS 7		0 11G	G09_060	'TO->FROM'	'SOUTHWESTERN STATION - WASHITA 138KV	CKT 1'	260	0.19083	134.8215	'GRACMNT4 138.00 - WASHITA 138KV	CKT 1'	
FDNS 00G09_060		0 11SP	G09_060	'TO->FROM'	'LAKE CREEK - LONEWOLF 69KV	CKT 1'	48	0.62326	110.3736	'GOTEBO - MOUNTAIN VIEW 69KV	CKT 1'	
FDNS 00G09_060		0 11SP	G09_060	'TO->FROM'	'LAKE CREEK - LONEWOLF 69KV	CKT 1'	48	0.62326	103.0202	'MOUNTAIN VIEW - PINE RIDGE 69KV	CKT 1'	
FDNS 00G09_060		0 11SP	G09_060	'TO->FROM'	'LAKE CREEK - LONEWOLF 69KV	CKT 1'	48	0.27034	115.2564	'ELK CITY (ELKCTY-4) 138/69/13.8KV	TRANSFORMER	CKT 1'
FDNS 00G09_060		0 11WP	G09_060	'TO->FROM'	'LAKE CREEK - LONEWOLF 69KV	CKT 1'	48	0.62302	108.2708	'GOTEBO - MOUNTAIN VIEW 69KV	CKT 1'	
FDNS 00G09_060		0 11WP	G09_060	'TO->FROM'	'LAKE CREEK - LONEWOLF 69KV	CKT 1'	48	0.62302	103.329	'MOUNTAIN VIEW - PINE RIDGE 69KV	CKT 1'	
FDNS 00G09_060		0 11WP	G09_060	'TO->FROM'	'LAKE CREEK - LONEWOLF 69KV	CKT 1'	48	0.27128	101.8572	'ELK CITY (ELKCTY-4) 138/69/13.8KV	TRANSFORMER	CKT 1'
FDNS 00G09_060		0 16SP	G09_060	'TO->FROM'	'LAKE CREEK - LONEWOLF 69KV	CKT 1'	48	0.62404	110.8705	'GOTEBO - MOUNTAIN VIEW 69KV	CKT 1'	
FDNS 00G09_060		0 16SP	G09_060	'TO->FROM'	'LAKE CREEK - LONEWOLF 69KV	CKT 1'	48	0.62404	103.0355	'MOUNTAIN VIEW - PINE RIDGE 69KV	CKT 1'	
FDNS 00G09_060		0 16SP	G09_060	'TO->FROM'	'LAKE CREEK - LONEWOLF 69KV	CKT 1'	48	0.27164	119.3225	'ELK CITY (ELKCTY-4) 138/69/13.8KV	TRANSFORMER	CKT 1'
FDNS 00G09_060		0 16WP	G09_060	'TO->FROM'	'LAKE CREEK - LONEWOLF 69KV	CKT 1'	48	0.62303	102.8888	'MOUNTAIN VIEW - PINE RIDGE 69KV	CKT 1'	
FDNS 00G09_060		0 16WP	G09_060	'TO->FROM'	'LAKE CREEK - LONEWOLF 69KV	CKT 1'	48	0.27134	106.983	'ELK CITY (ELKCTY-4) 138/69/13.8KV	TRANSFORMER	CKT 1'
FDNS 00G09_060		0 11SP	G09_060	'TO->FROM'	'LAKE CREEK - LONEWOLF 69KV	CKT 1'	48	0.62326	110.3736	'GOTEBO - MOUNTAIN VIEW 69KV	CKT 1'	
FDNS 00G09_060		0 11SP	G09_060	'TO->FROM'	'LAKE CREEK - LONEWOLF 69KV	CKT 1'	48	0.62326	103.0202	'MOUNTAIN VIEW - PINE RIDGE 69KV	CKT 1'	
FDNS 00G09_060		0 11SP	G09_060	'TO->FROM'	'LAKE CREEK - LONEWOLF 69KV	CKT 1'	48	0.27034	115.2564	'ELK CITY (ELKCTY-4) 138/69/13.8KV	TRANSFORMER	CKT 1'
FDNS 00G09_060		0 11WP	G09_060	'TO->FROM'	'LAKE CREEK - LONEWOLF 69KV	CKT 1'	48	0.62302	108.2708	'GOTEBO - MOUNTAIN VIEW 69KV	CKT 1'	
FDNS 00G09_060		0 11WP	G09_060	'TO->FROM'	'LAKE CREEK - LONEWOLF 69KV	CKT 1'	48	0.62302	103.329	'MOUNTAIN VIEW - PINE RIDGE 69KV	CKT 1'	
FDNS 00G09_060		0 11WP	G09_060	'TO->FROM'	'LAKE CREEK - LONEWOLF 69KV	CKT 1'	48	0.27128	101.8572	'ELK CITY (ELKCTY-4) 138/69/13.8KV	TRANSFORMER	CKT 1'
FDNS 00G09_060		0 16SP	G09_060	'TO->FROM'	'LAKE CREEK - LONEWOLF 69KV	CKT 1'	48	0.62404	110.8705	'GOTEBO - MOUNTAIN VIEW 69KV	CKT 1'	
FDNS 00G09_060		0 16SP	G09_060	'TO->FROM'	'LAKE CREEK - LONEWOLF 69KV	CKT 1'	48	0.62404	103.0355	'MOUNTAIN VIEW - PINE RIDGE 69KV	CKT 1'	
FDNS 00G09_060		0 16SP	G09_060	'TO->FROM'	'LAKE CREEK - LONEWOLF 69KV	CKT 1'	48	0.27164	119.3225	'ELK CITY (ELKCTY-4) 138/69/13.8KV	TRANSFORMER	CKT 1'
FDNS 00G09_060		0 16WP	G09_060	'TO->FROM'	'LAKE CREEK - LONEWOLF 69KV	CKT 1'	48	0.62303	108.0434	'GOTEBO - MOUNTAIN VIEW 69KV	CKT 1'	
FDNS 00G09_060		0 16WP	G09_060	'TO->FROM'	'LAKE CREEK - LONEWOLF 69KV	CKT 1'	48	0.62303	102.8888	'MOUNTAIN VIEW - PINE RIDGE 69KV	CKT 1'	
FDNS 00G09_060		0 16WP	G09_060	'TO->FROM'	'LAKE CREEK - LONEWOLF 69KV	CKT 1'	48	0.27134	106.983	'ELK CITY (ELKCTY-4) 138/69/13.8KV	TRANSFORMER	CKT 1'
FDNS 00G09_060		0 16WP	G09_060	'TO->FROM'	'LAKE CREEK - LONEWOLF 69KV	CKT 1'	48	0.27134	106.983	'ELK CITY (ELKCTY-4) 138/69/13.8KV	TRANSFORMER	CKT 1'
FDNS 07G0960		0 11G	G09_060	'TO->FROM'	'SOUTHWESTERN STATION - WASHITA 138KV	CKT 1'	260	0.19079	135.333	'GRACMNT4 138.00 - WASHITA 138KV	CKT 1'	
FDNS 07G0960		0 11G	G09_060	'TO->FROM'	'SOUTHWESTERN STATION - WASHITA 138KV	CKT 1'	260	0.19079	135.333	'GRACMNT4 138.00 - WASHITA 138KV	CKT 1'	
FNSL-Itera 02ALL		0 11G	G09_060		Non Converged		0	0.19159	9999	'DBL-G0847-WO'		
FNSL-Itera 02ALL		0 11G	G09_060		Non Converged		0	0.14032	9999	'SPP-SWPS-02'		
FNSL-Itera 02ALL		0 11G	G09_060		Non Converged		1052	0.12237	76.82405	'FINNEY SWITCHING STATION - STEVENSCO	345.00 345KV	CKT 1'
FNSL-Itera 02ALL		0 11G	G09_060		Non Converged		441	0.10561	56.82947	'STLN-DEMARC6230.00 - SWEETWT6	230.00 230KV	CKT 1'
FNSL-Itera 02ALL		0 11G	G09_060		Non Converged		0	0.08072	9999	'ATC_B2_8E2_G'		
FNSL-Itera 02ALL		0 11G	G09_060		Non Converged		0	0.07832	9999	'050 1'		
FNSL-Itera 02ALL		0 11G	G09_060		Non Converged		0	0.07807	9999	'050 1'		
FNSL-Itera 02ALL		0 11G	G09_060		Non Converged		0	0.07546	9999	'ATC_B2_8E2'		
FNSL-Itera 02ALL		0 11G	G09_060		Non Converged		0	0.07378	9999	'050 2'		
FNSL-Itera 02ALL		0 11G	G09_060		Non Converged		441	0.07011	57.29366	'STLN-DEMARC6230.00 - SWEETWT6	230.00 230KV	CKT 1'
FNSL-Itera 02ALL		0 11G	G09_060		Non Converged		0	0.0548	9999	'ATC_B2_8E2_G'		
FNSL-Blow 02ALL		0 11G	G09_060		Non Converged		0	0.05249	9999	'SPP-SWPS-03'		
FNSL-Itera 02ALL		0 11G	G09_060		Non Converged		0	0.04964	9999	'050 2'		
FNSL-Itera 02ALL		0 11G	G09_060		Non Converged		441	0.0415	56.03129	'STLN-DEMARC6230.00 - SWEETWT6	230.00 230KV	CKT 1'
FNSL-Itera 02ALL		0 11G	G09_060		Non Converged		0	0.03155	9999	'ATC_B2_8E2_G'		

SOLUTION GROUP	SCENARIK	SEASON	SOURCE	DIRECTION	MONITORED ELEMENT	COMMON NAME	RATEB	TDF	TC%	LOAD	CONTINGENCY	NAME		
FNSL-Itera 02ALL		0 11G	G09_060			Non Converged		0	0.03		9999	'050 1'		
FNSL-Itera 02ALL		0 11G	G09_060			Non Converged		0	0.02793		9999	'050 2'		
FNSL-Itera 02ALL		0 11G	G09_060			Non Converged		0	0.02541		9999	'SPP-SWPS-03'		
FNSL-Itera 02ALL		0 11G	G09_060			Non Converged		0	0.02261		9999	'050 1'		
FNSL-Itera 02ALL		0 11G	G09_060			Non Converged		441	0.02205	56.87944	'STATELINE INTERCHANGE - STLN-DEMARC6230.00	230KV CKT		
FNSL-Itera 02ALL		0 11G	G09_060			Non Converged		192	0.05316	19.07647	'ALTUS JCT TAP - ALTUS JUNCTION 138KV	CKT 1'		
FNSL-Itera 02ALL		0 11G	G09_060			Non Converged		72	0.05316	45.80798	'ALTUS JCT TAP - RUSSELL 138KV	CKT 1'		
FNSL-Itera 02ALL		2 11G	G09_060			Non Converged		72	0.05334	41.71536	'ALTUS JCT TAP - RUSSELL 138KV	CKT 1'		
FDNS 03G0962		0 11G	G09_062	'FROM->TO'	'HOLCOMB (HOLCOMB) 345/115/13.8KV TRANSFORMI		336	0.54243	100.9	'G05-12	345.00 -	'SPEARVILLE 345KV	CKT 1'	
FDNS 03G0962		0 11G	G09_062	'FROM->TO'	'G08-79T 115.00 - JUDSON LARGE 115KV	CKT 1'	129.5	0.38135	102.3369	'HOLCOMB (HOLCOMB) 345/115/13.8KV	TRANSFORMER	CKT 1'		
FDNS 03G0962		0 11G	G09_062	'FROM->TO'	'HOLCOMB (HOLCOMB) 345/115/13.8KV TRANSFORMI		336	0.54243	100.9	'G05-12	345.00	345/34.5KV	TRANSFORMER	CKT 1'
FDNS 03G0962		0 11G	G09_062	'FROM->TO'	'HOLCOMB (HOLCOMB) 345/115/13.8KV TRANSFORMI		336	0.54243	100.9	'G05-12	345.00 -	'SPEARVILLE 345KV	CKT 1'	
FDNS 03G0962		0 11G	G09_062	'FROM->TO'	'G08-79T 115.00 - JUDSON LARGE 115KV	CKT 1'	129.5	0.38135	102.3369	'HOLCOMB (HOLCOMB) 345/115/13.8KV	TRANSFORMER	CKT 1'		
FDNS 03G0962		0 11G	G09_062	'FROM->TO'	'HOLCOMB (HOLCOMB) 345/115/13.8KV TRANSFORMI		336	0.54243	100.9	'G05-12	345.00	345/34.5KV	TRANSFORMER	CKT 1'
FDNS 03G0962		2 11G	G09_062	'FROM->TO'	'HOLCOMB (HOLCOMB) 345/115/13.8KV TRANSFORMI		336	0.52478	97.8	'G05-12	345.00 -	'SPEARVILLE 345KV	CKT 1'	
FDNS 03G0962		2 11G	G09_062	'FROM->TO'	'SPEARVILLE (SPEARVL6) 230/115/13.8KV TRANSFOR		205	0.20894	102.6802	'SPEARVILLE (SPEARVLX) 345/115/13.8KV	TRANSFORMER	CKT 1'		
FDNS 03G0962		2 11G	G09_062	'FROM->TO'	'SPEARVILLE (SPEARVL6) 230/115/13.8KV TRANSFOR		205	0.20894	103.2196	'SPEARVILLE (SPEARVLX) 345/115/13.8KV	TRANSFORMER	CKT 1'		
FDNS 03G0962		2 11G	G09_062	'FROM->TO'	'HOLCOMB (HOLCOMB) 345/115/13.8KV TRANSFORMI		336	0.52478	97.8	'G05-12	345.00	345/34.5KV	TRANSFORMER	CKT 1'
FDNS 03G0962		2 11G	G09_062	'FROM->TO'	'HOLCOMB (HOLCOMB) 345/115/13.8KV TRANSFORMI		336	0.52478	97.8	'G05-12	345.00 -	'SPEARVILLE 345KV	CKT 1'	
FDNS 03G0962		2 11G	G09_062	'FROM->TO'	'SPEARVILLE (SPEARVL6) 230/115/13.8KV TRANSFOR		205	0.20894	102.6802	'SPEARVILLE (SPEARVLX) 345/115/13.8KV	TRANSFORMER	CKT 1'		
FDNS 03G0962		2 11G	G09_062	'FROM->TO'	'SPEARVILLE (SPEARVL6) 230/115/13.8KV TRANSFOR		205	0.20894	103.2196	'SPEARVILLE (SPEARVLX) 345/115/13.8KV	TRANSFORMER	CKT 1'		
FDNS 03G0962		2 11G	G09_062	'FROM->TO'	'HOLCOMB (HOLCOMB) 345/115/13.8KV TRANSFORMI		336	0.52478	97.8	'G05-12	345.00	345/34.5KV	TRANSFORMER	CKT 1'
FNSL-Itera 00G09_06;		0 11WP	G09_062			Non Converged		0	0.04219		9999	'TRF-STEGALL'		
FNSL-Blow 00G09_06;		0 16SP	G09_062			Non Converged		0	0.04496		9999	'TRF-STEGALL'		
FNSL-Blow 00G09_06;		0 16WP	G09_062			Non Converged		0	0.04335		9999	'TRF-STEGALL'		
FNSL-Blow		0 16SP	G09_062			Non Converged		0	0.04496		9999	'TRF-STEGALL'		
FNSL-Itera		0 11WP	G09_062			Non Converged		0	0.04219		9999	'TRF-STEGALL'		
FNSL-Blow		0 16WP	G09_062			Non Converged		0	0.04335		9999	'TRF-STEGALL'		
FDNS 1		2 11G	G09_067S	'FROM->TO'	'DEAF SMITH COUNTY INTERCHANGE - S-RANDLCO		350	0.20322	96.5	'TOLK STATION EAST 230/24.0KV	TRANSFORMER	CKT 1'		
FDNS 1		2 11G	G09_067S	'FROM->TO'	'DEAF SMITH COUNTY INTERCHANGE - S-RANDLCO		350	0.20322	96.5	'TOLK STATION EAST 230/24.0KV	TRANSFORMER	CKT 1'		
FDNS 2		0 11G	G09_067S	'FROM->TO'	'DEAF SMITH COUNTY INTERCHANGE - S-RANDLCO		350	0.20666	116.9	'TOLK STATION EAST 230/24.0KV	TRANSFORMER	CKT 1'		
FDNS 2		0 11G	G09_067S	'TO->FROM'	'FINNEY SWITCHING STATION - STEVENSCO 345.00		1052	0.20126	111.9602	'DBL-HIT-G084'				
FDNS 2		0 11G	G09_067S	'FROM->TO'	'DEAF SMITH COUNTY INTERCHANGE - S-RANDLCO		350	0.20666	116.9	'TOLK STATION EAST 230/24.0KV	TRANSFORMER	CKT 1'		
FDNS 2		0 11G	G09_067S	'TO->FROM'	'FINNEY SWITCHING STATION - STEVENSCO 345.00		1052	0.20126	111.9602	'DBL-HIT-G084'				
FDNS 2		2 11G	G09_067S	'FROM->TO'	'DEAF SMITH COUNTY INTERCHANGE - S-RANDLCO		350	0.20377	106	'TOLK STATION EAST 230/24.0KV	TRANSFORMER	CKT 1'		
FDNS 2		2 11G	G09_067S	'FROM->TO'	'DEAF SMITH COUNTY INTERCHANGE - S-RANDLCO		350	0.20377	106	'TOLK STATION EAST 230/24.0KV	TRANSFORMER	CKT 1'		
FDNS 3		2 11G	G09_067S	'FROM->TO'	'DEAF SMITH COUNTY INTERCHANGE - S-RANDLCO		350	0.20498	98.5	'TOLK STATION EAST 230/24.0KV	TRANSFORMER	CKT 1'		
FDNS 3		2 11G	G09_067S	'FROM->TO'	'DEAF SMITH COUNTY INTERCHANGE - S-RANDLCO		350	0.20498	98.5	'TOLK STATION EAST 230/24.0KV	TRANSFORMER	CKT 1'		
FDNS 5		0 11G	G09_067S	'FROM->TO'	'DEAF SMITH COUNTY INTERCHANGE - S-RANDLCO		350	0.20899	108.2	'OKLAUN - OKLAUNION 345KV	CKT 1'			
FDNS 5		0 11G	G09_067S	'FROM->TO'	'DEAF SMITH COUNTY INTERCHANGE - S-RANDLCO		350	0.20899	104.3	'ASGI-10-11 69.000 - TRI COUNTY REC-TEXAS COUNTY	INTERC			
FDNS 5		0 11G	G09_067S	'FROM->TO'	'DEAF SMITH COUNTY INTERCHANGE - S-RANDLCO		350	0.20899	102.7	'G02-006 115.00 - TEXAS COUNTY INTERCHANGE 115KV	CKT 1'			
FDNS 5		0 11G	G09_067S	'FROM->TO'	'DEAF SMITH COUNTY INTERCHANGE - S-RANDLCO		350	0.20899	101.8	'G07-46 115.00 - HITCHLAND INTERCHANGE 115KV	CKT 1'			
FDNS 5		0 11G	G09_067S	'FROM->TO'	'DEAF SMITH COUNTY INTERCHANGE - S-RANDLCO		350	0.20899	103.7	'HUBER GEN - INDUSTRIAL SUB 69KV	CKT 1'			
FDNS 5		0 11G	G09_067S	'FROM->TO'	'DEAF SMITH COUNTY INTERCHANGE - S-RANDLCO		350	0.20899	103.7	'INDUSTRIAL SUB - SID RICHARDSON (PHILLIPS) GEN 69KV	CKT			
FDNS 5		0 11G	G09_067S	'FROM->TO'	'DEAF SMITH COUNTY INTERCHANGE - S-RANDLCO		350	0.20899	102.4	'VEGA SUB - WILDORADO 69KV	CKT 1'			
FDNS 5		0 11G	G09_067S	'FROM->TO'	'DEAF SMITH COUNTY INTERCHANGE - S-RANDLCO		350	0.20899	102.1	'G08-88 69.000 - VEGA SUB 69KV	CKT 1'			
FDNS 5		0 11G	G09_067S	'FROM->TO'	'DEAF SMITH COUNTY INTERCHANGE - S-RANDLCO		350	0.20899	102.5	'SWITCH 2749 - WILDORADO 69KV	CKT 1'			
FDNS 5		0 11G	G09_067S	'FROM->TO'	'DEAF SMITH COUNTY INTERCHANGE - S-RANDLCO		350	0.20899	102.5	'SOUTHWEST PORTLAND CEMENT TAP - SWITCH 2749 69KV	CK			
FDNS 5		0 11G	G09_067S	'FROM->TO'	'DEAF SMITH COUNTY INTERCHANGE - S-RANDLCO		350	0.20899	102.5	'NORTHWEST TAP - SOUTHWEST PORTLAND CEMENT TAP 69K				
FDNS 5		0 11G	G09_067S	'FROM->TO'	'DEAF SMITH COUNTY INTERCHANGE - S-RANDLCO		350	0.20899	102.5	'MAJESTC_WND3115.00 - MARTIN 3115.00 115KV	CKT 1'			
FDNS 5		0 11G	G09_067S	'FROM->TO'	'DEAF SMITH COUNTY INTERCHANGE - S-RANDLCO		350	0.20899	102	'Golden Spread REC - Mustang Interchange 230 kV	Generation Bus -			
FDNS 5		0 11G	G09_067S	'FROM->TO'	'DEAF SMITH COUNTY INTERCHANGE - S-RANDLCO		350	0.20899	102.1	'G03-013 345.00 - STEVENSCO 345.00 345KV	CKT 1'			
FDNS 5		0 11G	G09_067S	'FROM->TO'	'DEAF SMITH COUNTY INTERCHANGE - S-RANDLCO		350	0.20899	100.7	'2008-047 TP345.00 - G08-47 345.00 345KV	CKT 1'			
FDNS 5		0 11G	G09_067S	'FROM->TO'	'DEAF SMITH COUNTY INTERCHANGE - S-RANDLCO		350	0.20899	103.9	'G05-15T 345.00 - G08-14 345.00 345KV	CKT 1'			
FDNS 5		0 11G	G09_067S	'FROM->TO'	'DEAF SMITH COUNTY INTERCHANGE - S-RANDLCO		350	0.20899	103.9	'G10-07 115.00 - G10-07T 115.00 115KV	CKT 1'			
FDNS 5		0 11G	G09_067S	'FROM->TO'	'DEAF SMITH COUNTY INTERCHANGE - S-RANDLCO		350	0.20899	103.9	'G05-15 345.00 - G05-15T 345.00 345KV	CKT 1'			
FDNS 5		0 11G	G09_067S	'FROM->TO'	'DEAF SMITH COUNTY INTERCHANGE - S-RANDLCO		350	0.20899	103.8	'G05-17 345.00	345/115KV	TRANSFORMER	CKT 1'	
FDNS 5		0 11G	G09_067S	'FROM->TO'	'DEAF SMITH COUNTY INTERCHANGE - S-RANDLCO		350	0.20899	103.8	'G05-17-2 115.00 - G05-17-2 115.00 115KV	CKT 1'			
FDNS 5		0 11G	G09_067S	'FROM->TO'	'DEAF SMITH COUNTY INTERCHANGE - S-RANDLCO		350	0.20899	104.3	'G06-44 115.00 - G06-44-1 115.00 115KV	CKT 1'			
FDNS 5		0 11G	G09_067S	'FROM->TO'	'DEAF SMITH COUNTY INTERCHANGE - S-RANDLCO		350	0.20899	103.1	'G06-44 115.00 - G06-44-2 115.00 115KV	CKT 1'			
FDNS 5		0 11G	G09_067S	'FROM->TO'	'DEAF SMITH COUNTY INTERCHANGE - S-RANDLCO		350	0.20899	102.3	'G06-44 115.00 - G06-44-3 115.00 115KV	CKT 1'			
FDNS 5		0 11G	G09_067S	'FROM->TO'	'DEAF SMITH COUNTY INTERCHANGE - S-RANDLCO		350	0.20899	100.6	'Hitchland Interchange 345/0.575KV	TRANSFORMER	CKT 1'		
FDNS 5		0 11G	G09_067S	'FROM->TO'	'DEAF SMITH COUNTY INTERCHANGE - S-RANDLCO		350	0.20899	101.3	'Hitchland Interchange (PRO G2218-01) 345/115/13.8KV	TRANSFOF			
FDNS 5		0 11G	G09_067S	'FROM->TO'	'DEAF SMITH COUNTY INTERCHANGE - S-RANDLCO		350	0.20899	139.9	'TOLK STATION EAST 230/24.0KV	TRANSFORMER	CKT 1'		
FDNS 5		0 11G	G09_067S	'FROM->TO'	'DEAF SMITH COUNTY INTERCHANGE - S-RANDLCO		350	0.20899	104.1	'JONES STATION 230/22.0KV	TRANSFORMER	CKT 1'		
FDNS 5		0 11G	G09_067S	'FROM->TO'	'DEAF SMITH COUNTY INTERCHANGE - S-RANDLCO		350	0.20899	104.1	'Jones Station Bus#2 230/22.0KV	TRANSFORMER	CKT 1'		
FDNS 5		0 11G	G09_067S	'FROM->TO'	'DEAF SMITH COUNTY INTERCHANGE - S-RANDLCO		350	0.20899	104	'GRASSLAND INTERCHANGE 230/34.5KV	TRANSFORMER	CKT 1'		

SOLUTION GROUP	SCENARIK	SEASON	SOURCE	DIRECTION	MONITORED ELEMENT	COMMON NAME	RATEB	TDF	TC%	LOAD CONTINGENCY	NAME
FDNS	5	0 11G	G09_067S	'FROM->TO'	'DEAF SMITH COUNTY INTERCHANGE - S-RANDLCO		350	0.20899	101.8	'G07-46	115.00 115/34.5KV TRANSFORMER CKT 1'
FDNS	5	0 11G	G09_067S	'FROM->TO'	'DEAF SMITH COUNTY INTERCHANGE - S-RANDLCO		350	0.20899	102.7	'G02-006	115.00 115/34.5KV TRANSFORMER CKT 1'
FDNS	5	0 11G	G09_067S	'FROM->TO'	'DEAF SMITH COUNTY INTERCHANGE - S-RANDLCO		350	0.20899	103.7	'G03-013	345.00 345/34.5KV TRANSFORMER CKT 1'
FDNS	5	0 11G	G09_067S	'FROM->TO'	'DEAF SMITH COUNTY INTERCHANGE - S-RANDLCO		350	0.20899	103.7	'G03-013	345.00 345/34.5KV TRANSFORMER CKT 1'
FDNS	5	0 11G	G09_067S	'FROM->TO'	'DEAF SMITH COUNTY INTERCHANGE - S-RANDLCO		350	0.20899	103.1	'G05-17	345.00 345/34.5KV TRANSFORMER CKT 1'
FDNS	5	0 11G	G09_067S	'FROM->TO'	'DEAF SMITH COUNTY INTERCHANGE - S-RANDLCO		350	0.20899	103.1	'G05-17	345.00 345/34.5KV TRANSFORMER CKT 1'
FDNS	5	0 11G	G09_067S	'FROM->TO'	'DEAF SMITH COUNTY INTERCHANGE - S-RANDLCO		350	0.20899	103.8	'G05-17-2	115.00 115/34.5KV TRANSFORMER CKT 1'
FDNS	5	0 11G	G09_067S	'FROM->TO'	'DEAF SMITH COUNTY INTERCHANGE - S-RANDLCO		350	0.20899	104.3	'G06-44-1	115.00 115/34.5KV TRANSFORMER CKT 1'
FDNS	5	0 11G	G09_067S	'FROM->TO'	'DEAF SMITH COUNTY INTERCHANGE - S-RANDLCO		350	0.20899	103.1	'G06-44-2	115.00 115/34.5KV TRANSFORMER CKT 1'
FDNS	5	0 11G	G09_067S	'FROM->TO'	'DEAF SMITH COUNTY INTERCHANGE - S-RANDLCO		350	0.20899	102.3	'G06-44-3	115.00 115/34.5KV TRANSFORMER CKT 1'
FDNS	02ALL	0 11G	G09_067S	'FROM->TO'	'DEAF SMITH COUNTY INTERCHANGE - S-RANDLCO		350	0.20593	101.9	'OKLAUN - OKLAUNION 345KV CKT 1'	
FDNS	02ALL	0 11G	G09_067S	'FROM->TO'	'DEAF SMITH COUNTY INTERCHANGE - S-RANDLCO		350	0.20593	133.6	'TOLK STATION EAST 230/24.0KV TRANSFORMER CKT 1'	
FDNS	02ALL	0 11G	G09_067S	'FROM->TO'	'DEAF SMITH COUNTY INTERCHANGE - S-RANDLCO		350	0.20593	101.9	'OKLAUN - OKLAUNION 345KV CKT 1'	
FDNS	02ALL	0 11G	G09_067S	'FROM->TO'	'DEAF SMITH COUNTY INTERCHANGE - S-RANDLCO		350	0.20593	133.6	'TOLK STATION EAST 230/24.0KV TRANSFORMER CKT 1'	
FDNS	02ALL	0 11G	G09_067S	'FROM->TO'	'DEAF SMITH COUNTY INTERCHANGE - S-RANDLCO		350	0.20816	104.8	'OKLAUN - OKLAUNION 345KV CKT 1'	
FDNS	02ALL	0 11G	G09_067S	'FROM->TO'	'DEAF SMITH COUNTY INTERCHANGE - S-RANDLCO		350	0.20816	98.6	'ASGI-10-11 69.000 - TRI COUNTY REC-TEXAS COUNTY INTERC	
FDNS	02ALL	0 11G	G09_067S	'FROM->TO'	'DEAF SMITH COUNTY INTERCHANGE - S-RANDLCO		350	0.20816	100.8	'HUBER GEN - INDUSTRIAL SUB 69KV CKT 1'	
FDNS	02ALL	0 11G	G09_067S	'FROM->TO'	'DEAF SMITH COUNTY INTERCHANGE - S-RANDLCO		350	0.20816	100.8	'INDUSTRIAL SUB - SID RICHARDSON (PHILLIPS) GEN 69KV CKT	
FDNS	02ALL	0 11G	G09_067S	'FROM->TO'	'DEAF SMITH COUNTY INTERCHANGE - S-RANDLCO		350	0.20816	96.2	'FINNEY SWITCHING STATION - G08-18 345.00 345KV CKT 1'	
FDNS	02ALL	0 11G	G09_067S	'FROM->TO'	'DEAF SMITH COUNTY INTERCHANGE - S-RANDLCO		350	0.20816	96.5	'G08-51 345.00 - POTTER COUNTY INTERCHANGE 345KV CKT	
FDNS	02ALL	0 11G	G09_067S	'FROM->TO'	'DEAF SMITH COUNTY INTERCHANGE - S-RANDLCO		350	0.20816	100.7	'G05-21 115.00 - KIRBY SWITCHING STATION 115KV CKT 1'	
FDNS	02ALL	0 11G	G09_067S	'FROM->TO'	'DEAF SMITH COUNTY INTERCHANGE - S-RANDLCO		350	0.20816	95.4	'BUSHLAND INTERCHANGE - WILDORADO WIND GEN 230KV CK	
FDNS	02ALL	0 11G	G09_067S	'FROM->TO'	'DEAF SMITH COUNTY INTERCHANGE - S-RANDLCO		350	0.20816	99.4	'Golden Spread REC - Mustang Interchange 230 kV Generation Bus -	
FDNS	02ALL	0 11G	G09_067S	'FROM->TO'	'DEAF SMITH COUNTY INTERCHANGE - S-RANDLCO		350	0.20816	95.9	'G06-45 230.00 - S-RANDLCO 230.00 230KV CKT 1'	
FDNS	02ALL	0 11G	G09_067S	'FROM->TO'	'DEAF SMITH COUNTY INTERCHANGE - S-RANDLCO		350	0.20816	96	'G06-47 230.00 - S-RANDLCO 230.00 230KV CKT 1'	
FDNS	02ALL	0 11G	G09_067S	'FROM->TO'	'DEAF SMITH COUNTY INTERCHANGE - S-RANDLCO		350	0.20816	100.9	'G05-15T 345.00 - G08-14 345.00 345KV CKT 1'	
FDNS	02ALL	0 11G	G09_067S	'FROM->TO'	'DEAF SMITH COUNTY INTERCHANGE - S-RANDLCO		350	0.20816	96.1	'G10-07 115.00 - G10-07T 115.00 115KV CKT 1'	
FDNS	02ALL	0 11G	G09_067S	'FROM->TO'	'DEAF SMITH COUNTY INTERCHANGE - S-RANDLCO		350	0.20816	100.9	'G05-15 345.00 - G05-15T 345.00 345KV CKT 1'	
FDNS	02ALL	0 11G	G09_067S	'FROM->TO'	'DEAF SMITH COUNTY INTERCHANGE - S-RANDLCO		350	0.20816	95.7	'G05-17 345.00 345/115KV TRANSFORMER CKT 1'	
FDNS	02ALL	0 11G	G09_067S	'FROM->TO'	'DEAF SMITH COUNTY INTERCHANGE - S-RANDLCO		350	0.20816	95.7	'G05-17-2 115.00 - G05-17-2 115.00 115KV CKT 1'	
FDNS	02ALL	0 11G	G09_067S	'FROM->TO'	'DEAF SMITH COUNTY INTERCHANGE - S-RANDLCO		350	0.20816	98	'G06-44 115.00 - G06-44-1 115.00 115KV CKT 1'	
FDNS	02ALL	0 11G	G09_067S	'FROM->TO'	'DEAF SMITH COUNTY INTERCHANGE - S-RANDLCO		350	0.20816	101.2	'SHERMAN COUNTY SUB 115/34.5KV TRANSFORMER CKT 1'	
FDNS	02ALL	0 11G	G09_067S	'FROM->TO'	'DEAF SMITH COUNTY INTERCHANGE - S-RANDLCO		350	0.20816	100.6	'MOORE COUNTY INTERCHANGE EAST BUS 115/13.2KV TRANSI	
FDNS	02ALL	0 11G	G09_067S	'FROM->TO'	'DEAF SMITH COUNTY INTERCHANGE - S-RANDLCO		350	0.20816	101	'DUMAS SUB 115/34.5KV TRANSFORMER CKT 1'	
FDNS	02ALL	0 11G	G09_067S	'FROM->TO'	'DEAF SMITH COUNTY INTERCHANGE - S-RANDLCO		350	0.20816	97.2	'WILDORADO WIND GEN 230/34.5KV TRANSFORMER CKT 1'	
FDNS	02ALL	0 11G	G09_067S	'FROM->TO'	'DEAF SMITH COUNTY INTERCHANGE - S-RANDLCO		350	0.20816	138.2	'TOLK STATION EAST 230/24.0KV TRANSFORMER CKT 1'	
FDNS	02ALL	0 11G	G09_067S	'FROM->TO'	'DEAF SMITH COUNTY INTERCHANGE - S-RANDLCO		350	0.20816	101.2	'JONES STATION 230/22.0KV TRANSFORMER CKT 1'	
FDNS	02ALL	0 11G	G09_067S	'FROM->TO'	'DEAF SMITH COUNTY INTERCHANGE - S-RANDLCO		350	0.20816	101.2	'Jones Station Bus#2 230/22.0KV TRANSFORMER CKT 1'	
FDNS	02ALL	0 11G	G09_067S	'FROM->TO'	'DEAF SMITH COUNTY INTERCHANGE - S-RANDLCO		350	0.20816	100.9	'GRASSLAND INTERCHANGE 230/34.5KV TRANSFORMER CKT 1'	
FDNS	02ALL	0 11G	G09_067S	'FROM->TO'	'DEAF SMITH COUNTY INTERCHANGE - S-RANDLCO		350	0.20816	101.1	'MUSTANG STATION N. 115/13.8KV TRANSFORMER CKT 1'	
FDNS	02ALL	0 11G	G09_067S	'FROM->TO'	'DEAF SMITH COUNTY INTERCHANGE - S-RANDLCO		350	0.20816	101.1	'MUSTANG STATION S. 115/13.8KV TRANSFORMER CKT 1'	
FDNS	02ALL	0 11G	G09_067S	'FROM->TO'	'DEAF SMITH COUNTY INTERCHANGE - S-RANDLCO		350	0.20816	101.1	'Golden Spread REC - Mustang Interchange 230 kV Generation Bus ;	
FDNS	02ALL	0 11G	G09_067S	'FROM->TO'	'DEAF SMITH COUNTY INTERCHANGE - S-RANDLCO		350	0.20816	101.2	'Golden Spread REC - Mustang Interchange 230 kV Generation Bus ;	
FDNS	02ALL	0 11G	G09_067S	'FROM->TO'	'DEAF SMITH COUNTY INTERCHANGE - S-RANDLCO		350	0.20816	101.2	'Golden Spread REC - Mustang Interchange 230 kV Generation Bus ;	
FDNS	02ALL	0 11G	G09_067S	'FROM->TO'	'DEAF SMITH COUNTY INTERCHANGE - S-RANDLCO		350	0.20816	101	'HOBBS INTERCHANGE 230/18.0KV TRANSFORMER CKT 1'	
FDNS	02ALL	0 11G	G09_067S	'FROM->TO'	'DEAF SMITH COUNTY INTERCHANGE - S-RANDLCO		350	0.20816	100.1	'HOLCOMB 115/22.0KV TRANSFORMER CKT 1'	
FDNS	02ALL	0 11G	G09_067S	'FROM->TO'	'DEAF SMITH COUNTY INTERCHANGE - S-RANDLCO		350	0.20816	96.5	'G07-48T 230.00 230/34.5KV TRANSFORMER CKT 1'	
FDNS	02ALL	0 11G	G09_067S	'FROM->TO'	'DEAF SMITH COUNTY INTERCHANGE - S-RANDLCO		350	0.20816	100.9	'G08-14 345.00 345/34.5KV TRANSFORMER CKT 1'	
FDNS	02ALL	0 11G	G09_067S	'FROM->TO'	'DEAF SMITH COUNTY INTERCHANGE - S-RANDLCO		350	0.20816	96.1	'G10-07 115.00 115/34.5KV TRANSFORMER CKT 1'	
FDNS	02ALL	0 11G	G09_067S	'FROM->TO'	'DEAF SMITH COUNTY INTERCHANGE - S-RANDLCO		350	0.20816	98.6	'ASGI-10-11 69.000 69/34.5KV TRANSFORMER CKT 1'	
FDNS	02ALL	0 11G	G09_067S	'FROM->TO'	'DEAF SMITH COUNTY INTERCHANGE - S-RANDLCO		350	0.20816	96.2	'G08-18 345.00 345/34.5KV TRANSFORMER CKT 1'	
FDNS	02ALL	0 11G	G09_067S	'FROM->TO'	'DEAF SMITH COUNTY INTERCHANGE - S-RANDLCO		350	0.20816	95	'G03-013 345.00 345/34.5KV TRANSFORMER CKT 1'	
FDNS	02ALL	0 11G	G09_067S	'FROM->TO'	'DEAF SMITH COUNTY INTERCHANGE - S-RANDLCO		350	0.20816	95	'G03-013 345.00 345/34.5KV TRANSFORMER CKT 1'	
FDNS	02ALL	0 11G	G09_067S	'FROM->TO'	'DEAF SMITH COUNTY INTERCHANGE - S-RANDLCO		350	0.20816	95.7	'G05-17-2 115.00 115/34.5KV TRANSFORMER CKT 1'	
FDNS	02ALL	0 11G	G09_067S	'FROM->TO'	'DEAF SMITH COUNTY INTERCHANGE - S-RANDLCO		350	0.20816	100.7	'G05-21 115.00 115/34.5KV TRANSFORMER CKT 1'	
FDNS	02ALL	0 11G	G09_067S	'FROM->TO'	'DEAF SMITH COUNTY INTERCHANGE - S-RANDLCO		350	0.20816	98	'G06-44-1 115.00 115/34.5KV TRANSFORMER CKT 1'	
FDNS	02ALL	0 11G	G09_067S	'FROM->TO'	'DEAF SMITH COUNTY INTERCHANGE - S-RANDLCO		350	0.20816	95.9	'G06-45 230.00 230/34.5KV TRANSFORMER CKT 1'	
FDNS	02ALL	0 11G	G09_067S	'FROM->TO'	'DEAF SMITH COUNTY INTERCHANGE - S-RANDLCO		350	0.20816	95.9	'G06-47 230.00 230/34.5KV TRANSFORMER CKT 1'	
FDNS	02ALL	2 11G	G09_067S	'FROM->TO'	'DEAF SMITH COUNTY INTERCHANGE - S-RANDLCO		350	0.20507	123.2	'TOLK STATION EAST 230/24.0KV TRANSFORMER CKT 1'	
FDNS	02ALL	3 11G	G09_067S	'FROM->TO'	'DEAF SMITH COUNTY INTERCHANGE - S-RANDLCO		350	0.20577	120.8	'TOLK STATION EAST 230/24.0KV TRANSFORMER CKT 1'	
FDNS	02G08110	0 11G	G09_067S	'FROM->TO'	'DEAF SMITH COUNTY INTERCHANGE - S-RANDLCO		350	0.20686	122.2	'TOLK STATION EAST 230/24.0KV TRANSFORMER CKT 1'	
FDNS	02G08110	0 11G	G09_067S	'TO->FROM'	'FINNEY SWITCHING STATION - STEVENSCO 345.00		1052	0.19465	132.1299	'DBL-HIT-G084'	
FDNS	02G08110	2 11G	G09_067S	'FROM->TO'	'DEAF SMITH COUNTY INTERCHANGE - S-RANDLCO		350	0.20395	109.8	'TOLK STATION EAST 230/24.0KV TRANSFORMER CKT 1'	
FDNS	02G08110	3 11G	G09_067S	'FROM->TO'	'DEAF SMITH COUNTY INTERCHANGE - S-RANDLCO		350	0.20471	108.1	'TOLK STATION EAST 230/24.0KV TRANSFORMER CKT 1'	
FDNS	02G0847	0 11G	G09_067S	'FROM->TO'	'DEAF SMITH COUNTY INTERCHANGE - S-RANDLCO		350	0.20701	121.9	'TOLK STATION EAST 230/24.0KV TRANSFORMER CKT 1'	
FDNS	02G0847	0 11G	G09_067S	'TO->FROM'	'FINNEY SWITCHING STATION - STEVENSCO 345.00		1052	0.19588	128.0221	'DBL-HIT-G084'	
FDNS	02G0847	2 11G	G09_067S	'FROM->TO'	'DEAF SMITH COUNTY INTERCHANGE - S-RANDLCO		350	0.20411	109.5	'TOLK STATION EAST 230/24.0KV TRANSFORMER CKT 1'	

SOLUTION GROUP	SCENARIK	SEASON	SOURCE	DIRECTION	MONITORED ELEMENT	COMMON NAME	RATEB	TDF	TC%	LOAD	CONTINGENCY	NAME
FDNS	02G0847	3	11G	G09_067S	'FROM->TO'	'DEAF SMITH COUNTY INTERCHANGE - S-RANDLCO	350	0.20486	107.7	'TOLK STATION EAST 230/24.0KV TRANSFORMER CKT 1'		
FDNS	02G1007	0	11G	G09_067S	'FROM->TO'	'DEAF SMITH COUNTY INTERCHANGE - S-RANDLCO	350	0.20692	121	'TOLK STATION EAST 230/24.0KV TRANSFORMER CKT 1'		
FDNS	02G1007	0	11G	G09_067S	'TO->FROM'	'FINNEY SWITCHING STATION - STEVENSCO 345.00	1052	0.19555	128.8406	'DBL-HIT-G084'		
FDNS	02G1007	2	11G	G09_067S	'FROM->TO'	'DEAF SMITH COUNTY INTERCHANGE - S-RANDLCO	350	0.20404	108.9	'TOLK STATION EAST 230/24.0KV TRANSFORMER CKT 1'		
FDNS	02G1007	3	11G	G09_067S	'FROM->TO'	'DEAF SMITH COUNTY INTERCHANGE - S-RANDLCO	350	0.2048	107.1	'TOLK STATION EAST 230/24.0KV TRANSFORMER CKT 1'		
FDNS	02G1014	0	11G	G09_067S	'FROM->TO'	'DEAF SMITH COUNTY INTERCHANGE - S-RANDLCO	350	0.20697	121.8	'TOLK STATION EAST 230/24.0KV TRANSFORMER CKT 1'		
FDNS	02G1014	0	11G	G09_067S	'TO->FROM'	'FINNEY SWITCHING STATION - STEVENSCO 345.00	1052	0.19444	133.3729	'DBL-HIT-G084'		
FDNS	02G1014	2	11G	G09_067S	'FROM->TO'	'DEAF SMITH COUNTY INTERCHANGE - S-RANDLCO	350	0.20406	109.3	'TOLK STATION EAST 230/24.0KV TRANSFORMER CKT 1'		
FDNS	02G1014	3	11G	G09_067S	'FROM->TO'	'DEAF SMITH COUNTY INTERCHANGE - S-RANDLCO	350	0.20482	107.6	'TOLK STATION EAST 230/24.0KV TRANSFORMER CKT 1'		
FDNS	2	0	11G	G09_067S	'FROM->TO'	'DEAF SMITH COUNTY INTERCHANGE - S-RANDLCO	350	0.20689	120.7	'TOLK STATION EAST 230/24.0KV TRANSFORMER CKT 1'		
FDNS	2	0	11G	G09_067S	'TO->FROM'	'FINNEY SWITCHING STATION - STEVENSCO 345.00	1052	0.19577	128.0433	'DBL-HIT-G084'		
FDNS	2	2	11G	G09_067S	'FROM->TO'	'DEAF SMITH COUNTY INTERCHANGE - S-RANDLCO	350	0.20402	108.6	'TOLK STATION EAST 230/24.0KV TRANSFORMER CKT 1'		
FDNS	2	3	11G	G09_067S	'FROM->TO'	'DEAF SMITH COUNTY INTERCHANGE - S-RANDLCO	350	0.20477	106.9	'TOLK STATION EAST 230/24.0KV TRANSFORMER CKT 1'		
FNSL-Itera 02ALL		0	11G	G09_067S		Non Converged	0	0.17136		'SPP-SWPS-03'		
FNSL-Itera 02ALL		0	11G	G09_067S		Non Converged	1052	0.13545	97.33807	'FINNEY SWITCHING STATION - STEVENSCO 345.00 345KV CKT'		
FNSL-Itera 02ALL		0	11G	G09_067S		Non Converged	1052	0.1208	77.23053	'FINNEY SWITCHING STATION - STEVENSCO 345.00 345KV CKT'		
FNSL-Itera 02ALL		0	11G	G09_067S		Non Converged	351	0.09753	82.03278	'GRAPEVINE INTERCHANGE - NICHOLS STATION 230KV CKT 1'		
FNSL-Itera 02ALL		0	11G	G09_067S		Non Converged	0	0.08064	9999	'ATC_B2_8E2_G'		
FNSL-Itera 02ALL		0	11G	G09_067S		Non Converged	0	0.0783	9999	'050 1'		
FNSL-Itera 02ALL		0	11G	G09_067S		Non Converged	0	0.07558	9999	'ATC_B2_8E2'		
FNSL-Itera 02ALL		0	11G	G09_067S		Non Converged	0	0.07534	9999	'ATC_B2_8E2'		
FNSL-Itera 02ALL		0	11G	G09_067S		Non Converged	0	0.07377	9999	'050 2'		
FNSL-Itera 02ALL		0	11G	G09_067S		Non Converged	351	0.06435	82.03278	'GRAPEVINE INTERCHANGE - NICHOLS STATION 230KV CKT 1'		
FNSL-Blow 02ALL		0	11G	G09_067S		Non Converged	351	0.05446	81.98898	'GRAPEVINE INTERCHANGE - NICHOLS STATION 230KV CKT 1'		
FNSL-Itera 02ALL		0	11G	G09_067S		Non Converged	0	0.05243	9999	'SPP-SWPS-03'		
FNSL-Itera 02ALL		0	11G	G09_067S		Non Converged	0	0.04962	9999	'050 2'		
FNSL-Itera 02ALL		0	11G	G09_067S		Non Converged	441	0.04144	56.55862	'STLN-DEMARC6230.00 - SWEETWT6 230.00 230KV CKT 1'		
FNSL-Itera 02ALL		0	11G	G09_067S		Non Converged	0	0.03146	9999	'ATC_B2_8E2_G'		
FNSL-Itera 02ALL		0	11G	G09_067S		Non Converged	0	0.02995	9999	'050 1'		
FNSL-Itera 02ALL		0	11G	G09_067S		Non Converged	0	0.02784	9999	'050 2'		
FNSL-Itera 02ALL		0	11G	G09_067S		Non Converged	0	0.02348	9999	'ATC_B2_8E2_G'		
FNSL-Itera 02ALL		0	11G	G09_067S		Non Converged	0	0.02245	9999	'050 1'		
FNSL-Itera 02ALL		0	11G	G09_067S		Non Converged	441	0.022	57.61415	'STATELINE INTERCHANGE - STLN-DEMARC6230.00 230KV CKT'		
FNSL-Blow 02ALL		0	11G	G09_067S		Non Converged	1052	0.11273	97.33807	'FINNEY SWITCHING STATION - STEVENSCO 345.00 345KV CKT'		
FNSL-Blow 02ALL		0	11G	G09_067S		Non Converged	0	0.12763	9999	'DBL-HIT-G084'		
FNSL-Blow 02ALL		0	11G	G09_067S		Non Converged	0	0.10607	9999	'DBL-G0847-WO'		
FNSL-Itera 02ALL		0	11G	G09_067S		Non Converged	0	0.04485	9999	'SPP-SWPS-T53'		
FNSL-Itera 02ALL		2	11G	G09_067S		Non Converged	1052	0.12109	82.65054	'FINNEY SWITCHING STATION - STEVENSCO 345.00 345KV CKT'		
FNSL-Itera 02ALL		2	11G	G09_067S		Non Converged	0	0.13769	9999	'DBL-G0847-WO'		
FNSL-Blow 02G08110		0	11G	G09_067S		Non Converged	0	0.11864	9999	'DBL-G0847-WO'		
FNSL-Itera 02G08110		0	11G	G09_067S		Non Converged	0	0.14028	9999	'SPP-SWPS-02'		
FNSL-Itera 02G08110		0	11G	G09_067S		Non Converged	441	0.07014	56.82947	'STLN-DEMARC6230.00 - SWEETWT6 230.00 230KV CKT 1'		
FNSL-Itera 02G08110		0	11G	G09_067S		Non Converged	441	0.07014	57.15012	'STATELINE INTERCHANGE - STLN-DEMARC6230.00 230KV CKT'		
FNSL-Itera 02G08110		3	11G	G09_067S		Non Converged	0	0.12691	9999	'SPP-SWPS-03'		
FNSL-Itera 02G0847		0	11G	G09_067S		Non Converged	441	0.07011	57.61415	'STATELINE INTERCHANGE - STLN-DEMARC6230.00 230KV CKT'		
FNSL-Itera 02G0847		0	11G	G09_067S		Non Converged	0	0.11695	9999	'DBL-G0847-WO'		
FNSL-Itera 02G0847		0	11G	G09_067S		Non Converged	0	0.14022	9999	'SPP-SWPS-02'		
FNSL-Itera 02G0847		0	11G	G09_067S		Non Converged	441	0.07011	57.29366	'STLN-DEMARC6230.00 - SWEETWT6 230.00 230KV CKT 1'		
FNSL-Itera 02G0847		0	11G	G09_067S		Non Converged	351	0.06435	82.03278	'GRAPEVINE INTERCHANGE - NICHOLS STATION 230KV CKT 1'		
FNSL-Itera 02G0847		3	11G	G09_067S		Non Converged	0	0.12688	9999	'SPP-SWPS-03'		
FNSL-Itera 02G1007		0	11G	G09_067S		Non Converged	441	0.07016	56.55862	'STLN-DEMARC6230.00 - SWEETWT6 230.00 230KV CKT 1'		
FNSL-Itera 02G1007		0	11G	G09_067S		Non Converged	441	0.07016	56.87944	'STATELINE INTERCHANGE - STLN-DEMARC6230.00 230KV CKT'		
FNSL-Itera 02G1007		0	11G	G09_067S		Non Converged	1052	0.1208	77.23053	'FINNEY SWITCHING STATION - STEVENSCO 345.00 345KV CKT'		
FNSL-Itera 02G1007		0	11G	G09_067S		Non Converged	0	0.11946	9999	'DBL-G0847-WO'		
FNSL-Itera 02G1007		0	11G	G09_067S		Non Converged	0	0.14032	9999	'SPP-SWPS-02'		
FNSL-Itera 02G1007		2	11G	G09_067S		Non Converged	0	0.14818	9999	'DBL-G0847-WO'		
FNSL-Itera 02G1007		3	11G	G09_067S		Non Converged	0	0.12692	9999	'SPP-SWPS-03'		
FNSL-Itera 02G1014		0	11G	G09_067S		Non Converged	0	0.11841	9999	'DBL-G0847-WO'		
FNSL-Itera 02G1014		0	11G	G09_067S		Non Converged	0	0.14019	9999	'SPP-SWPS-02'		
FNSL-Itera 02G1014		0	11G	G09_067S		Non Converged	441	0.0701	57.2667	'STLN-DEMARC6230.00 - SWEETWT6 230.00 230KV CKT 1'		
FNSL-Itera 02G1014		0	11G	G09_067S		Non Converged	351	0.06434	81.98898	'GRAPEVINE INTERCHANGE - NICHOLS STATION 230KV CKT 1'		
FNSL-Itera 02G1014		0	11G	G09_067S		Non Converged	441	0.0701	57.58744	'STATELINE INTERCHANGE - STLN-DEMARC6230.00 230KV CKT'		
FNSL-Itera 02G1014		3	11G	G09_067S		Non Converged	0	0.12686	9999	'SPP-SWPS-03'		
FNSL-Itera		2	0	11G	G09_067S		441	0.07022	56.03129	'STLN-DEMARC6230.00 - SWEETWT6 230.00 230KV CKT 1'		
FNSL-Itera		2	0	11G	G09_067S		441	0.07022	56.34883	'STATELINE INTERCHANGE - STLN-DEMARC6230.00 230KV CKT'		
FNSL-Itera		2	0	11G	G09_067S		1052	0.12092	76.82405	'FINNEY SWITCHING STATION - STEVENSCO 345.00 345KV CKT'		
FNSL-Blow		2	0	11G	G09_067S		0	0.11965	9999	'DBL-G0847-WO'		

SOLUTION GROUP	SCENARI	SEASON	SOURCE	DIRECTION	MONITORED ELEMENT	COMMON NAME	RATEB	TDF	TC%	LOAD	CONTINGENCY	NAME
FNSL-Itera	2	0 11G	G09_067S		Non Converged		0	0.14045	9999	'SPP-SWPS-02'		
FNSL-Itera	2	2 11G	G09_067S		Non Converged		0	0.14833	9999	'DBL-G0847-WO'		
FNSL-Itera	2	3 11G	G09_067S		Non Converged		0	0.12703	9999	'SPP-SWPS-03'		
FNSL-Blow 03ALL		0 11G	G09_067S		Non Converged		0	0.12831	9999	'DBL-MEDLO-WI'		
FNSL-Itera 06G0967S		0 11G	G09_067S		Non Converged		0	0.13887	9999	'SPP-SWPS-03'		
FNSL-Itera	6	0 11G	G09_067S		Non Converged		0	0.13889	9999	'SPP-SWPS-03'		
FNSL-Itera 02ALL		0 11G	G10_003		Non Converged		1052	0.15854	77.23053	'FINNEY SWITCHING STATION - STEVENSCO	345.00	345KV CKT
FNSL-Itera 02ALL		0 11G	G10_003		Non Converged		0	0.12911	9999	'SPP-SWPS-03'		
FNSL-Itera 02ALL		0 11G	G10_003		Non Converged		441	0.11746	56.55862	'STLN-DEMARC6230.00 - SWEETWT6	230.00	230KV CKT 1'
FNSL-Itera 02ALL		0 11G	G10_003		Non Converged		0	0.083	9999	'SPP-SWPS-02'		
FNSL-Itera 02ALL		0 11G	G10_003		Non Converged		0	0.08062	9999	'ATC_B2_8E2_G'		
FNSL-Itera 02ALL		0 11G	G10_003		Non Converged		0	0.07823	9999	'050 1'		
FNSL-Itera 02ALL		0 11G	G10_003		Non Converged		0	0.07557	9999	'ATC_B2_8E2'		
FNSL-Itera 02ALL		0 11G	G10_003		Non Converged		0	0.07389	9999	'050 2'		
FNSL-Itera 02ALL		0 11G	G10_003		Non Converged		0	0.0736	9999	'050 2'		
FNSL-Itera 02ALL		0 11G	G10_003		Non Converged		441	0.06337	57.15012	'STATELINE INTERCHANGE - STLN-DEMARC6230.00	230KV	CKT
FNSL-Blow 02ALL		0 11G	G10_003		Non Converged		0	0.05291	9999	'050 1'		
FNSL-Itera 02ALL		0 11G	G10_003		Non Converged		0	0.05104	9999	'ATC_B2_8E2'		
FNSL-Itera 02ALL		0 11G	G10_003		Non Converged		0	0.04572	9999	'SPP-SWPS-T53'		
FNSL-Itera 02ALL		0 11G	G10_003		Non Converged		441	0.04142	57.15012	'STATELINE INTERCHANGE - STLN-DEMARC6230.00	230KV	CKT
FNSL-Itera 02ALL		0 11G	G10_003		Non Converged		0	0.0314	9999	'ATC_B2_8E2_G'		
FNSL-Itera 02ALL		0 11G	G10_003		Non Converged		0	0.02904	9999	'ATC_B2_8E2'		
FNSL-Itera 02ALL		0 11G	G10_003		Non Converged		0	0.02778	9999	'050 2'		
FNSL-Itera 02ALL		0 11G	G10_003		Non Converged		0	0.02345	9999	'ATC_B2_8E2_G'		
FNSL-Itera 02ALL		0 11G	G10_003		Non Converged		0	0.02223	9999	'050 1'		
FNSL-Itera 02ALL		0 11G	G10_003		Non Converged		0	0.02197	9999	'ATC_B2_8E2_G'		
FNSL-Itera 02ALL		0 11G	G10_005		Non Converged		1052	0.15866	76.82405	'FINNEY SWITCHING STATION - STEVENSCO	345.00	345KV CKT
FNSL-Itera 02ALL		0 11G	G10_005		Non Converged		0	0.12913	9999	'SPP-SWPS-03'		
FNSL-Itera 02ALL		0 11G	G10_005		Non Converged		441	0.11752	56.34883	'STATELINE INTERCHANGE - STLN-DEMARC6230.00	230KV	CKT
FNSL-Itera 02ALL		0 11G	G10_005		Non Converged		0	0.09472	9999	'SPP-SWPS-03'		
FNSL-Itera 02ALL		0 11G	G10_005		Non Converged		0	0.08062	9999	'ATC_B2_8E2_G'		
FNSL-Itera 02ALL		0 11G	G10_005		Non Converged		0	0.07823	9999	'050 1'		
FNSL-Itera 02ALL		0 11G	G10_005		Non Converged		0	0.07557	9999	'ATC_B2_8E2'		
FNSL-Itera 02ALL		0 11G	G10_005		Non Converged		0	0.07389	9999	'050 2'		
FNSL-Itera 02ALL		0 11G	G10_005		Non Converged		0	0.0736	9999	'050 2'		
FNSL-Itera 02ALL		0 11G	G10_005		Non Converged		441	0.06337	56.82947	'STLN-DEMARC6230.00 - SWEETWT6	230.00	230KV CKT 1'
FNSL-Blow 02ALL		0 11G	G10_005		Non Converged		0	0.05291	9999	'050 1'		
FNSL-Itera 02ALL		0 11G	G10_005		Non Converged		0	0.05104	9999	'ATC_B2_8E2'		
FNSL-Itera 02ALL		0 11G	G10_005		Non Converged		0	0.04946	9999	'050 2'		
FNSL-Itera 02ALL		0 11G	G10_005		Non Converged		441	0.04142	57.15012	'STATELINE INTERCHANGE - STLN-DEMARC6230.00	230KV	CKT
FNSL-Itera 02ALL		0 11G	G10_005		Non Converged		0	0.03141	9999	'ATC_B2_8E2_G'		
FNSL-Itera 02ALL		0 11G	G10_005		Non Converged		0	0.02904	9999	'ATC_B2_8E2'		
FNSL-Itera 02ALL		0 11G	G10_005		Non Converged		0	0.02779	9999	'050 2'		
FNSL-Itera 02ALL		0 11G	G10_005		Non Converged		0	0.02346	9999	'ATC_B2_8E2_G'		
FNSL-Itera 02ALL		0 11G	G10_005		Non Converged		0	0.02233	9999	'050 1'		
FNSL-Itera 02ALL		0 11G	G10_005		Non Converged		441	0.02199	57.58744	'STATELINE INTERCHANGE - STLN-DEMARC6230.00	230KV	CKT
FNSL-Itera 06G1006		0 11G	G10_006		Non Converged		0	0.1142	9999	'SPP-SWPS-03'		
FDNS	2	0 11G	G10_007	'TO->FROM'	'FINNEY SWITCHING STATION - STEVENSCO	345.00	1052	0.34986	111.9602	'DBL-HIT-G084'		
FNSL-Itera	2	0 11G	G10_007		Non Converged		0	0.29424	9999	'DBL-G0847-WO'		
FDNS	2	0 11G	G10_007	'TO->FROM'	'FINNEY SWITCHING STATION - STEVENSCO	345.00	1052	0.34986	111.9602	'DBL-HIT-G084'		
FNSL-Itera	2	0 11G	G10_007		Non Converged		0	0.29424	9999	'DBL-G0847-WO'		
FNSL-Itera	6	0 11G	G10_007		Non Converged		0	0.19265	9999	'SPP-SWPS-03'		
FNSL-Itera	6	0 11G	G10_007		Non Converged		0	0.19265	9999	'SPP-SWPS-03'		
FNSL-Blow 02ALL		0 11G	G10_007		Non Converged		1052	0.21462	86.2944	'FINNEY SWITCHING STATION - STEVENSCO	345.00	345KV CKT
FDNS 02ALL		0 11G	G10_007	'FROM->TO'	'HITCHLAND INTERCHANGE (H TP80148301) 230/115/'		250	0.19587	101.6998	'G05-17T 345.00 - Hitchland Interchange	345KV	CKT 1'
FDNS 02ALL		0 11G	G10_007	'FROM->TO'	'HITCHLAND INTERCHANGE (H TP80148301) 230/115/'		250	0.19587	101.8499	'G05-17T 345.00 - Hitchland Interchange	345KV	CKT 1'
FNSL-Blow 02ALL		0 11G	G10_007		Non Converged		1052	0.21462	86.2944	'FINNEY SWITCHING STATION - STEVENSCO	345.00	345KV CKT
FDNS 02ALL		0 11G	G10_007	'FROM->TO'	'HITCHLAND INTERCHANGE (H TP80148301) 230/115/'		250	0.19587	101.6998	'G05-17T 345.00 - Hitchland Interchange	345KV	CKT 1'
FDNS 02ALL		0 11G	G10_007	'FROM->TO'	'HITCHLAND INTERCHANGE (H TP80148301) 230/115/'		250	0.19587	101.8499	'G05-17T 345.00 - Hitchland Interchange	345KV	CKT 1'
FDNS 02G1007		0 11G	G10_007	'TO->FROM'	'FINNEY SWITCHING STATION - STEVENSCO	345.00	1052	0.34963	112.6583	'DBL-HIT-G084'		
FNSL-Itera 02G1007		0 11G	G10_007		Non Converged		0	0.29406	9999	'DBL-G0847-WO'		
FDNS 02G1007		0 11G	G10_007	'TO->FROM'	'FINNEY SWITCHING STATION - STEVENSCO	345.00	1052	0.34963	112.6583	'DBL-HIT-G084'		
FNSL-Itera 02G1007		0 11G	G10_007		Non Converged		0	0.29406	9999	'DBL-G0847-WO'		
FDNS 02G1007		2 11G	G10_007	'FROM->TO'	'HITCHLAND INTERCHANGE (H TP80148301) 230/115/'		250	0.19168	104.1139	'G05-17T 345.00 - Hitchland Interchange	345KV	CKT 1'
FDNS 02G1007		2 11G	G10_007	'FROM->TO'	'HITCHLAND INTERCHANGE (H TP80148301) 230/115/'		250	0.19168	104.1678	'G05-17T 345.00 - Hitchland Interchange	345KV	CKT 1'
FDNS 02G1007		2 11G	G10_007	'FROM->TO'	'HITCHLAND INTERCHANGE (H TP80148301) 230/115/'		250	0.19168	104.1139	'G05-17T 345.00 - Hitchland Interchange	345KV	CKT 1'
FDNS 02G1007		2 11G	G10_007	'FROM->TO'	'HITCHLAND INTERCHANGE (H TP80148301) 230/115/'		250	0.19168	104.1678	'G05-17T 345.00 - Hitchland Interchange	345KV	CKT 1'

SOLUTION GROUP	SCENARI	SEASON	SOURCE	DIRECTION	MONITORED ELEMENT COMMON NAME	RATEB	TDF	TC%	LOAD	CONTINGENCY NAME
FDNS	02ALL	0 11G	G10_007	'TO->FROM'	'FINNEY SWITCHING STATION - STEVENSCO 345.00	345.00	1052	0.22467	115.9808	'DBL-WOOD-MED'
FNSL-Blow	02ALL	0 11G	G10_007		Non Converged		0	0.29825	9999	'DBL-HIT-G084'
FNSL-Blow	02ALL	0 11G	G10_007		Non Converged		0	0.2767	9999	'DBL-G0847-WO'
FNSL-Itera	02ALL	2 11G	G10_007		Non Converged		0	0.21961	9999	'DBL-G0847-WO'
FDNS	02ALL	2 11G	G10_007	'FROM->TO'	'HITCHLAND INTERCHANGE (H TP80148301) 230/115/'	230/115/'	250	0.21969	102.2799	'HITCHLAND INTERCHANGE - OCHILTREE 6230.00 230KV CKT 1
FDNS	02ALL	2 11G	G10_007	'FROM->TO'	'HITCHLAND INTERCHANGE (H TP80148301) 230/115/'	230/115/'	250	0.21969	103.7996	'HITCHLAND INTERCHANGE - OCHILTREE 6230.00 230KV CKT 1
FDNS	02ALL	2 11G	G10_007	'FROM->TO'	'HITCHLAND INTERCHANGE (H TP80148301) 230/115/'	230/115/'	250	0.19103	99.5	'OCHILTREE 3115.00 - TEXAS FARMS SUB 115KV CKT 1'
FDNS	02ALL	2 11G	G10_007	'FROM->TO'	'HITCHLAND INTERCHANGE (H TP80148301) 230/115/'	230/115/'	250	0.19103	100.7134	'OCHILTREE 3115.00 - TEXAS FARMS SUB 115KV CKT 1'
FDNS	02ALL	2 11G	G10_007	'FROM->TO'	'HITCHLAND INTERCHANGE (H TP80148301) 230/115/'	230/115/'	250	0.19103	99.6	'SPEARMAN SUB - TEXAS FARMS SUB 115KV CKT 1'
FDNS	02ALL	2 11G	G10_007	'FROM->TO'	'HITCHLAND INTERCHANGE (H TP80148301) 230/115/'	230/115/'	250	0.19103	100.8207	'SPEARMAN SUB - TEXAS FARMS SUB 115KV CKT 1'
FDNS	02ALL	2 11G	G10_007	'FROM->TO'	'HITCHLAND INTERCHANGE (H TP80148301) 230/115/'	230/115/'	250	0.21969	102.3915	'OCHILTREE 6230.00 230/115KV TRANSFORMER CKT 1'
FDNS	02ALL	2 11G	G10_007	'FROM->TO'	'HITCHLAND INTERCHANGE (H TP80148301) 230/115/'	230/115/'	250	0.21969	103.9866	'OCHILTREE 6230.00 230/115KV TRANSFORMER CKT 1'
FDNS	02ALL	2 11G	G10_007	'FROM->TO'	'HITCHLAND INTERCHANGE (H TP80148301) 230/115/'	230/115/'	250	0.19103	100	'SPEARMAN INTERCHANGE - SPEARMAN SUB 115KV CKT 1'
FDNS	02ALL	2 11G	G10_007	'FROM->TO'	'HITCHLAND INTERCHANGE (H TP80148301) 230/115/'	230/115/'	250	0.19103	101.1982	'SPEARMAN INTERCHANGE - SPEARMAN SUB 115KV CKT 1'
FDNS	02ALL	2 11G	G10_007	'FROM->TO'	'HITCHLAND INTERCHANGE (H TP80148301) 230/115/'	230/115/'	250	0.19711	101.9045	'Harrington Station East Bus - PRINGLE INTERCHANGE 230KV CKT 1
FDNS	02ALL	2 11G	G10_007	'FROM->TO'	'HITCHLAND INTERCHANGE (H TP80148301) 230/115/'	230/115/'	250	0.19711	102.8671	'Harrington Station East Bus - PRINGLE INTERCHANGE 230KV CKT 1
FDNS	02ALL	2 11G	G10_007	'FROM->TO'	'HITCHLAND INTERCHANGE (H TP80148301) 230/115/'	230/115/'	250	0.22828	101.542	'G10-07T 115.00 - RIVERVIEW INTERCHANGE 115KV CKT 1'
FDNS	02ALL	2 11G	G10_007	'FROM->TO'	'HITCHLAND INTERCHANGE (H TP80148301) 230/115/'	230/115/'	250	0.22828	102.6054	'G10-07T 115.00 - RIVERVIEW INTERCHANGE 115KV CKT 1'
FDNS	02ALL	2 11G	G10_007	'FROM->TO'	'HITCHLAND INTERCHANGE (H TP80148301) 230/115/'	230/115/'	250	0.19711	101.9015	'PRINGLE INTERCHANGE (WH ALM12301) 230/115/13.2KV TRAN
FDNS	02ALL	2 11G	G10_007	'FROM->TO'	'HITCHLAND INTERCHANGE (H TP80148301) 230/115/'	230/115/'	250	0.19711	102.8604	'PRINGLE INTERCHANGE (WH ALM12301) 230/115/13.2KV TRAN
FDNS	02ALL	2 11G	G10_007	'TO->FROM'	'FINNEY SWITCHING STATION - STEVENSCO 345.00	345.00	1052	0.21906	99.5	'DBL-HIT-G084'
FDNS	02ALL	2 11G	G10_007	'TO->FROM'	'FINNEY SWITCHING STATION - STEVENSCO 345.00	345.00	1052	0.21509	107.259	'DBL-WOOD-MED'
FDNS	02ALL	2 11G	G10_007	'FROM->TO'	'HITCHLAND INTERCHANGE (H TP80148301) 230/115/'	230/115/'	250	0.20048	95.2	'SPP-SWPS-K31'
FDNS	02ALL	2 11G	G10_007	'FROM->TO'	'HITCHLAND INTERCHANGE (H TP80148301) 230/115/'	230/115/'	250	0.20048	96.2	'SPP-SWPS-K31'
FDNS	02ALL	2 11G	G10_007	'FROM->TO'	'HITCHLAND INTERCHANGE (H TP80148301) 230/115/'	230/115/'	250	0.19711	101.9012	'SPP-SWPS-K43'
FDNS	02ALL	2 11G	G10_007	'FROM->TO'	'HITCHLAND INTERCHANGE (H TP80148301) 230/115/'	230/115/'	250	0.19711	102.8601	'SPP-SWPS-K43'
FDNS	02ALL	3 11G	G10_007	'FROM->TO'	'HITCHLAND INTERCHANGE (H TP80148301) 230/115/'	230/115/'	250	0.22149	108.5896	'HITCHLAND INTERCHANGE - OCHILTREE 6230.00 230KV CKT 1
FDNS	02ALL	3 11G	G10_007	'FROM->TO'	'HITCHLAND INTERCHANGE (H TP80148301) 230/115/'	230/115/'	250	0.22149	110.2548	'HITCHLAND INTERCHANGE - OCHILTREE 6230.00 230KV CKT 1
FDNS	02ALL	3 11G	G10_007	'FROM->TO'	'HITCHLAND INTERCHANGE (H TP80148301) 230/115/'	230/115/'	250	0.19261	104.9146	'OCHILTREE 3115.00 - TEXAS FARMS SUB 115KV CKT 1'
FDNS	02ALL	3 11G	G10_007	'FROM->TO'	'HITCHLAND INTERCHANGE (H TP80148301) 230/115/'	230/115/'	250	0.19261	106.1879	'OCHILTREE 3115.00 - TEXAS FARMS SUB 115KV CKT 1'
FDNS	02ALL	3 11G	G10_007	'FROM->TO'	'HITCHLAND INTERCHANGE (H TP80148301) 230/115/'	230/115/'	250	0.19261	105.0342	'SPEARMAN SUB - TEXAS FARMS SUB 115KV CKT 1'
FDNS	02ALL	3 11G	G10_007	'FROM->TO'	'HITCHLAND INTERCHANGE (H TP80148301) 230/115/'	230/115/'	250	0.19261	106.3187	'SPEARMAN SUB - TEXAS FARMS SUB 115KV CKT 1'
FDNS	02ALL	3 11G	G10_007	'FROM->TO'	'HITCHLAND INTERCHANGE (H TP80148301) 230/115/'	230/115/'	250	0.22149	108.6757	'OCHILTREE 6230.00 230/115KV TRANSFORMER CKT 1'
FDNS	02ALL	3 11G	G10_007	'FROM->TO'	'HITCHLAND INTERCHANGE (H TP80148301) 230/115/'	230/115/'	250	0.22149	110.421	'OCHILTREE 6230.00 230/115KV TRANSFORMER CKT 1'
FDNS	02ALL	3 11G	G10_007	'FROM->TO'	'HITCHLAND INTERCHANGE (H TP80148301) 230/115/'	230/115/'	250	0.19261	105.3851	'SPEARMAN INTERCHANGE - SPEARMAN SUB 115KV CKT 1'
FDNS	02ALL	3 11G	G10_007	'FROM->TO'	'HITCHLAND INTERCHANGE (H TP80148301) 230/115/'	230/115/'	250	0.19261	106.6695	'SPEARMAN INTERCHANGE - SPEARMAN SUB 115KV CKT 1'
FDNS	02ALL	3 11G	G10_007	'FROM->TO'	'HITCHLAND INTERCHANGE (H TP80148301) 230/115/'	230/115/'	250	0.19842	106.2255	'Harrington Station East Bus - PRINGLE INTERCHANGE 230KV CKT 1
FDNS	02ALL	3 11G	G10_007	'FROM->TO'	'HITCHLAND INTERCHANGE (H TP80148301) 230/115/'	230/115/'	250	0.19842	107.2108	'Harrington Station East Bus - PRINGLE INTERCHANGE 230KV CKT 1
FDNS	02ALL	3 11G	G10_007	'FROM->TO'	'HITCHLAND INTERCHANGE (H TP80148301) 230/115/'	230/115/'	250	0.2297	106.0539	'G10-07T 115.00 - RIVERVIEW INTERCHANGE 115KV CKT 1'
FDNS	02ALL	3 11G	G10_007	'FROM->TO'	'HITCHLAND INTERCHANGE (H TP80148301) 230/115/'	230/115/'	250	0.2297	107.1922	'G10-07T 115.00 - RIVERVIEW INTERCHANGE 115KV CKT 1'
FDNS	02ALL	3 11G	G10_007	'FROM->TO'	'HITCHLAND INTERCHANGE (H TP80148301) 230/115/'	230/115/'	250	0.19133	97.8	'G05-17T 345.00 - POTTER COUNTY INTERCHANGE 345KV CKT 1'
FDNS	02ALL	3 11G	G10_007	'FROM->TO'	'HITCHLAND INTERCHANGE (H TP80148301) 230/115/'	230/115/'	250	0.19133	98.6	'G05-17T 345.00 - POTTER COUNTY INTERCHANGE 345KV CKT 1'
FDNS	02ALL	3 11G	G10_007	'FROM->TO'	'HITCHLAND INTERCHANGE (H TP80148301) 230/115/'	230/115/'	250	0.19842	106.245	'PRINGLE INTERCHANGE (WH ALM12301) 230/115/13.2KV TRAN
FDNS	02ALL	3 11G	G10_007	'FROM->TO'	'HITCHLAND INTERCHANGE (H TP80148301) 230/115/'	230/115/'	250	0.19842	107.226	'PRINGLE INTERCHANGE (WH ALM12301) 230/115/13.2KV TRAN
FDNS	02ALL	3 11G	G10_007	'TO->FROM'	'FINNEY SWITCHING STATION - STEVENSCO 345.00	345.00	1052	0.19262	113.9175	'DBL-G0847-WO'
FDNS	02ALL	3 11G	G10_007	'FROM->TO'	'HITCHLAND INTERCHANGE (H TP80148301) 230/115/'	230/115/'	250	0.20232	101.5929	'SPP-SWPS-K31'
FDNS	02ALL	3 11G	G10_007	'FROM->TO'	'HITCHLAND INTERCHANGE (H TP80148301) 230/115/'	230/115/'	250	0.19842	106.227	'SPP-SWPS-K43'
FDNS	02ALL	3 11G	G10_007	'FROM->TO'	'HITCHLAND INTERCHANGE (H TP80148301) 230/115/'	230/115/'	250	0.19842	107.2078	'SPP-SWPS-K43'
FNSL-Blow	02G08110	0 11G	G10_007		Non Converged		0	0.28927	9999	'DBL-G0847-WO'
FNSL-Itera	02G08110	0 11G	G10_007		Non Converged		0	0.21121	9999	'SPP-SWPS-02'
FDNS	02G08110	0 11G	G10_007	'TO->FROM'	'FINNEY SWITCHING STATION - STEVENSCO 345.00	345.00	1052	0.34324	132.1299	'DBL-HIT-G084'
FDNS	02G08110	0 11G	G10_007	'TO->FROM'	'FINNEY SWITCHING STATION - STEVENSCO 345.00	345.00	1052	0.23431	96.4	'DBL-WOOD-MED'
FDNS	02G08110	2 11G	G10_007	'TO->FROM'	'FINNEY SWITCHING STATION - STEVENSCO 345.00	345.00	1052	0.22275	97	'DBL-G0847-WO'
FDNS	02G08110	3 11G	G10_007	'FROM->TO'	'HITCHLAND INTERCHANGE (H TP80148301) 230/115/'	230/115/'	250	0.19237	98.4	'G05-17T 345.00 - Hitchland Interchange 345KV CKT 1'
FDNS	02G08110	3 11G	G10_007	'FROM->TO'	'HITCHLAND INTERCHANGE (H TP80148301) 230/115/'	230/115/'	250	0.19237	98.1	'G05-17T 345.00 - Hitchland Interchange 345KV CKT 1'
FNSL-Itera	02G0847	0 11G	G10_007		Non Converged		0	0.28758	9999	'DBL-G0847-WO'
FNSL-Itera	02G0847	0 11G	G10_007		Non Converged		0	0.21115	9999	'SPP-SWPS-02'
FDNS	02G0847	0 11G	G10_007	'TO->FROM'	'FINNEY SWITCHING STATION - STEVENSCO 345.00	345.00	1052	0.34447	128.0221	'DBL-HIT-G084'
FDNS	02G0847	0 11G	G10_007	'TO->FROM'	'FINNEY SWITCHING STATION - STEVENSCO 345.00	345.00	1052	0.23391	98	'DBL-WOOD-MED'
FNSL	02G0847	2 11G	G10_007	'TO->FROM'	'FINNEY SWITCHING STATION - STEVENSCO 345.00	345.00	1052	0.22211	99.7	'DBL-G0847-WO'
FDNS	02G0847	3 11G	G10_007	'FROM->TO'	'HITCHLAND INTERCHANGE (H TP80148301) 230/115/'	230/115/'	250	0.19242	98.1	'G05-17T 345.00 - Hitchland Interchange 345KV CKT 1'
FDNS	02G0847	3 11G	G10_007	'FROM->TO'	'HITCHLAND INTERCHANGE (H TP80148301) 230/115/'	230/115/'	250	0.19242	97.7	'G05-17T 345.00 - Hitchland Interchange 345KV CKT 1'
FDNS	02G1007	0 11G	G10_007	'TO->FROM'	'FINNEY SWITCHING STATION - STEVENSCO 345.00	345.00	1052	0.34415	128.8406	'DBL-HIT-G084'
FNSL-Itera	02G1007	0 11G	G10_007		Non Converged		0	0.29009	9999	'DBL-G0847-WO'
FNSL-Itera	02G1007	0 11G	G10_007		Non Converged		0	0.21125	9999	'SPP-SWPS-02'
FNSL-Itera	02G1007	2 11G	G10_007		Non Converged		0	0.2301	9999	'DBL-G0847-WO'
FDNS	02G1007	3 11G	G10_007	'FROM->TO'	'HITCHLAND INTERCHANGE (H TP80148301) 230/115/'	230/115/'	250	0.19217	100.5505	'G05-17T 345.00 - Hitchland Interchange 345KV CKT 1'

SOLUTION GROUP	SCENARIK	SEASON	SOURCE	DIRECTION	MONITORED ELEMENT	COMMON NAME	RATEB	TDF	TC%	LOAD	CONTINGENCY	NAME
FDNS	02G1007	3	11G	G10_007	'FROM->TO'	'HITCHLAND INTERCHANGE (H TP80148301) 230/115/'	250	0.19217	100.2829	'G05-17T	345.00	- Hitchland Interchange 345KV CKT 1'
FNSL-Itera	02G1014	0	11G	G10_007		Non Converged	0	0.28904	9999	'DBL-G0847-WO'		
FNSL-Itera	02G1014	0	11G	G10_007		Non Converged	0	0.21112	9999	'SPP-SWPS-02'		
FDNS	02G1014	0	11G	G10_007	'TO->FROM'	'FINNEY SWITCHING STATION - STEVENSCO 345.00	1052	0.34303	133.3729	'DBL-HIT-G084'		
FDNS	02G1014	0	11G	G10_007	'TO->FROM'	'FINNEY SWITCHING STATION - STEVENSCO 345.00	1052	0.23421	96.9	'DBL-WOOD-MED'		
FDNS	02G1014	2	11G	G10_007	'TO->FROM'	'FINNEY SWITCHING STATION - STEVENSCO 345.00	1052	0.22265	97.6	'DBL-G0847-WO'		
FDNS	02G1014	3	11G	G10_007	'FROM->TO'	'HITCHLAND INTERCHANGE (H TP80148301) 230/115/'	250	0.19238	98	'G05-17T	345.00	- Hitchland Interchange 345KV CKT 1'
FDNS	02G1014	3	11G	G10_007	'FROM->TO'	'HITCHLAND INTERCHANGE (H TP80148301) 230/115/'	250	0.19238	97.9	'G05-17T	345.00	- Hitchland Interchange 345KV CKT 1'
FDNS	2	0	11G	G10_007	'TO->FROM'	'FINNEY SWITCHING STATION - STEVENSCO 345.00	1052	0.34437	128.0433	'DBL-HIT-G084'		
FNSL-Blow	2	0	11G	G10_007		Non Converged	0	0.29028	9999	'DBL-G0847-WO'		
FNSL-Itera	2	0	11G	G10_007		Non Converged	0	0.21138	9999	'SPP-SWPS-02'		
FNSL-Itera	2	2	11G	G10_007		Non Converged	0	0.23025	9999	'DBL-G0847-WO'		
FDNS	2	3	11G	G10_007	'FROM->TO'	'HITCHLAND INTERCHANGE (H TP80148301) 230/115/'	250	0.19228	99.3	'G05-17T	345.00	- Hitchland Interchange 345KV CKT 1'
FDNS	2	3	11G	G10_007	'FROM->TO'	'HITCHLAND INTERCHANGE (H TP80148301) 230/115/'	250	0.19228	99.1	'G05-17T	345.00	- Hitchland Interchange 345KV CKT 1'
FNSL-Itera	02ALL	0	11G	G10_007		Non Converged	0	0.14818	9999	'DBL-G0847-WO'		
FNSL-Itera	02ALL	0	11G	G10_007		Non Converged	0	0.12688	9999	'SPP-SWPS-03'		
FNSL-Itera	02ALL	0	11G	G10_007		Non Converged	441	0.11739	57.2667	'STLN-DEMARC6230.00 - SWEETWT6	230.00	230KV CKT 1'
FNSL-Itera	02ALL	0	11G	G10_007		Non Converged	0	0.08277	9999	'SPP-SWPS-02'		
FNSL-Itera	02ALL	0	11G	G10_007		Non Converged	0	0.08061	9999	'ATC_B2_8E2_G'		
FNSL-Itera	02ALL	0	11G	G10_007		Non Converged	0	0.07821	9999	'050 1'		
FNSL-Itera	02ALL	0	11G	G10_007		Non Converged	0	0.0755	9999	'ATC_B2_8E2'		
FNSL-Itera	02ALL	0	11G	G10_007		Non Converged	0	0.07382	9999	'050 2'		
FNSL-Itera	02ALL	0	11G	G10_007		Non Converged	441	0.07144	57.15012	'STATELINE INTERCHANGE - STLN-DEMARC6230.00	230KV	CKT
FNSL-Itera	02ALL	0	11G	G10_007		Non Converged	0	0.05483	9999	'ATC_B2_8E2_G'		
FNSL-Blow	02ALL	0	11G	G10_007		Non Converged	0	0.0529	9999	'050 1'		
FNSL-Itera	02ALL	0	11G	G10_007		Non Converged	0	0.05103	9999	'ATC_B2_8E2'		
FNSL-Itera	02ALL	0	11G	G10_007		Non Converged	0	0.04406	9999	'SPP-SWPS-02'		
FNSL-Itera	02ALL	0	11G	G10_007		Non Converged	441	0.04137	57.2667	'STLN-DEMARC6230.00 - SWEETWT6	230.00	230KV CKT 1'
FNSL-Itera	02ALL	0	11G	G10_007		Non Converged	1052	0.03112	76.82405	'FINNEY SWITCHING STATION - STEVENSCO 345.00	345KV	CKT
FNSL-Itera	02ALL	0	11G	G10_007		Non Converged	0	0.02895	9999	'ATC_B2_8E2'		
FNSL-Itera	02ALL	0	11G	G10_007		Non Converged	0	0.02683	9999	'SPP-SWPS-T53'		
FNSL-Itera	02ALL	0	11G	G10_007		Non Converged	0	0.02319	9999	'ATC_B2_8E2_G'		
FNSL-Itera	02ALL	0	11G	G10_007		Non Converged	0	0.02213	9999	'ATC_B2_8E2_G'		
FNSL-Itera	02ALL	0	11G	G10_007		Non Converged	0	0.02181	9999	'ATC_B2_8E2'		
FNSL-Blow	02ALL	0	11G	G10_007		Non Converged	1052	0.1678	97.33807	'FINNEY SWITCHING STATION - STEVENSCO 345.00	345KV	CKT
FNSL-Blow	02ALL	0	11G	G10_007		Non Converged	0	0.29825	9999	'DBL-HIT-G084'		
FNSL-Blow	02ALL	0	11G	G10_007		Non Converged	0	0.2767	9999	'DBL-G0847-WO'		
FNSL-Itera	02ALL	0	11G	G10_007		Non Converged	0	0.06709	9999	'SPP-SWPS-T53'		
FNSL-Itera	02ALL	2	11G	G10_007		Non Converged	1052	0.15262	82.65054	'FINNEY SWITCHING STATION - STEVENSCO 345.00	345KV	CKT
FNSL-Itera	02ALL	2	11G	G10_007		Non Converged	0	0.21961	9999	'DBL-G0847-WO'		
FNSL-Blow	02G08110	0	11G	G10_007		Non Converged	0	0.28927	9999	'DBL-G0847-WO'		
FNSL-Itera	02G08110	0	11G	G10_007		Non Converged	0	0.21121	9999	'SPP-SWPS-02'		
FNSL-Itera	02G08110	0	11G	G10_007		Non Converged	441	0.10561	56.82947	'STLN-DEMARC6230.00 - SWEETWT6	230.00	230KV CKT 1'
FNSL-Itera	02G08110	0	11G	G10_007		Non Converged	441	0.10561	57.15012	'STATELINE INTERCHANGE - STLN-DEMARC6230.00	230KV	CKT
FNSL-Itera	02G0847	0	11G	G10_007		Non Converged	0	0.17125	9999	'SPP-SWPS-03'		
FNSL-Itera	02G0847	0	11G	G10_007		Non Converged	441	0.10557	57.61415	'STATELINE INTERCHANGE - STLN-DEMARC6230.00	230KV	CKT
FNSL-Itera	02G0847	0	11G	G10_007		Non Converged	0	0.28758	9999	'DBL-G0847-WO'		
FNSL-Itera	02G0847	0	11G	G10_007		Non Converged	0	0.21115	9999	'SPP-SWPS-02'		
FNSL-Itera	02G0847	0	11G	G10_007		Non Converged	441	0.10557	57.29366	'STLN-DEMARC6230.00 - SWEETWT6	230.00	230KV CKT 1'
FNSL-Itera	02G0847	0	11G	G10_007		Non Converged	351	0.08265	82.03278	'GRAPEVINE INTERCHANGE - NICHOLS STATION	230KV	CKT 1'
FNSL-Itera	02G0847	3	11G	G10_007		Non Converged	0	0.17122	9999	'SPP-SWPS-03'		
FNSL-Itera	02G1007	0	11G	G10_007		Non Converged	441	0.10562	56.55862	'STLN-DEMARC6230.00 - SWEETWT6	230.00	230KV CKT 1'
FNSL-Itera	02G1007	0	11G	G10_007		Non Converged	441	0.10562	56.87944	'STATELINE INTERCHANGE - STLN-DEMARC6230.00	230KV	CKT
FNSL-Itera	02G1007	0	11G	G10_007		Non Converged	1052	0.17587	77.23053	'FINNEY SWITCHING STATION - STEVENSCO 345.00	345KV	CKT
FNSL-Itera	02G1007	0	11G	G10_007		Non Converged	0	0.29009	9999	'DBL-G0847-WO'		
FNSL-Itera	02G1007	0	11G	G10_007		Non Converged	0	0.21125	9999	'SPP-SWPS-02'		
FNSL-Itera	02G1007	0	11G	G10_007		Non Converged	0	0.29406	9999	'DBL-G0847-WO'		
FNSL-Itera	02G1007	2	11G	G10_007		Non Converged	0	0.2301	9999	'DBL-G0847-WO'		
FNSL-Itera	02G1007	2	11G	G10_007		Non Converged	0	0.1735	9999	'SPP-SWPS-03'		
FNSL-Itera	02G1007	3	11G	G10_007		Non Converged	0	0.17126	9999	'SPP-SWPS-03'		
FNSL-Itera	02G1014	0	11G	G10_007		Non Converged	0	0.28904	9999	'DBL-G0847-WO'		
FNSL-Itera	02G1014	0	11G	G10_007		Non Converged	0	0.21112	9999	'SPP-SWPS-02'		
FNSL-Itera	02G1014	0	11G	G10_007		Non Converged	441	0.10556	57.2667	'STLN-DEMARC6230.00 - SWEETWT6	230.00	230KV CKT 1'
FNSL-Itera	02G1014	0	11G	G10_007		Non Converged	351	0.08264	81.98898	'GRAPEVINE INTERCHANGE - NICHOLS STATION	230KV	CKT 1'
FNSL-Itera	02G1014	0	11G	G10_007		Non Converged	441	0.10556	57.58744	'STATELINE INTERCHANGE - STLN-DEMARC6230.00	230KV	CKT
FNSL-Itera	02G1014	3	11G	G10_007		Non Converged	0	0.17119	9999	'SPP-SWPS-03'		
FNSL-Itera	2	0	11G	G10_007		Non Converged	441	0.10569	56.03129	'STLN-DEMARC6230.00 - SWEETWT6	230.00	230KV CKT 1'

SOLUTION GROUP	SCENARIK	SEASON	SOURCE	DIRECTION	MONITORED ELEMENT	COMMON NAME	RATEB	TDF	TC%	LOAD	CONTINGENCY	NAME
FNSL-Itera	2	0 11G	G10_007		Non Converged		441	0.10569	56.34883	'STATELINE INTERCHANGE - STLN-DEMARC6230.00	230KV	CKT
FNSL-Itera	2	0 11G	G10_007		Non Converged		1052	0.17598	76.82405	'FINNEY SWITCHING STATION - STEVENSCO	345.00	345KV CK'
FNSL-Blow	2	0 11G	G10_007		Non Converged		0	0.29028	9999	'DBL-G0847-WO'		
FNSL-Itera	2	0 11G	G10_007		Non Converged		0	0.21138	9999	'SPP-SWPS-02'		
FNSL-Itera	2	2 11G	G10_007		Non Converged		0	0.23025	9999	'DBL-G0847-WO'		
FNSL-Itera	2	3 11G	G10_007		Non Converged		0	0.17136	9999	'SPP-SWPS-03'		
FNSL-Blow 03ALL		0 11G	G10_007		Non Converged		0	0.15195	9999	'DBL-MEDLO-WI'		
FNSL-Itera	6	0 11G	G10_007		Non Converged		0	0.19265	9999	'SPP-SWPS-03'		
FDNS	1	0 11G	G10_008	'FROM->TO'	'FARGO JCT - WOODWARD 69KV	CKT 1'	65	0.92895	143.8521	'FT SUPPLY - IODINE 138KV	CKT 1'	
FDNS	1	0 11G	G10_008	'FROM->TO'	'FARGO JCT - WOODWARD 69KV	CKT 1'	65	0.92895	136.2704	'IODINE - MOORELAND 138KV	CKT 1'	
FDNS	1	0 11G	G10_008	'FROM->TO'	'FARGO JCT - WOODWARD 69KV	CKT 1'	65	0.92895	143.8521	'FT SUPPLY - IODINE 138KV	CKT 1'	
FDNS	1	0 11G	G10_008	'FROM->TO'	'FARGO JCT - WOODWARD 69KV	CKT 1'	65	0.92895	136.2704	'IODINE - MOORELAND 138KV	CKT 1'	
FDNS	01G1008	0 11G	G10_008	'FROM->TO'	'FARGO JCT - WOODWARD 69KV	CKT 1'	65	0.77173	109.4979	'BASE CASE'		
FDNS	01G1008	0 11G	G10_008	'FROM->TO'	'FARGO JCT - WOODWARD 69KV	CKT 1'	65	0.78021	100.6781	'BUFBEAR2 - BUFFALO 69KV	CKT 1'	
FDNS	01G1008	0 11G	G10_008	'FROM->TO'	'FARGO JCT - WOODWARD 69KV	CKT 1'	65	0.92852	162.7939	'FT SUPPLY - IODINE 138KV	CKT 1'	
FDNS	01G1008	0 11G	G10_008	'FROM->TO'	'FARGO JCT - WOODWARD 69KV	CKT 1'	65	0.92852	155.1578	'IODINE - MOORELAND 138KV	CKT 1'	
FDNS	01G1008	0 11G	G10_008	'FROM->TO'	'FARGO JCT - WOODWARD 69KV	CKT 1'	65	0.77173	109.4979	'BASE CASE'		
FDNS	01G1008	0 11G	G10_008	'FROM->TO'	'FARGO JCT - WOODWARD 69KV	CKT 1'	65	0.78021	100.6781	'BUFBEAR2 - BUFFALO 69KV	CKT 1'	
FDNS	01G1008	0 11G	G10_008	'FROM->TO'	'FARGO JCT - WOODWARD 69KV	CKT 1'	65	0.92852	162.7939	'FT SUPPLY - IODINE 138KV	CKT 1'	
FDNS	01G1008	0 11G	G10_008	'FROM->TO'	'FARGO JCT - WOODWARD 69KV	CKT 1'	65	0.92852	155.1578	'IODINE - MOORELAND 138KV	CKT 1'	
FDNS	02ALL	0 11G	G10_008	'TO->FROM'	'NORTHWEST - TATONGA7	345.00 345KV CKT 1'	1195	0.20948	108.4191	'DBL-WOOD-MED'		
FDNS	02ALL	2 11G	G10_008	'TO->FROM'	'NORTHWEST - TATONGA7	345.00 345KV CKT 1'	1195	0.20487	112.4579	'DBL-WOOD-MED'		
FDNS	02G08110	0 11G	G10_008	'TO->FROM'	'NORTHWEST - TATONGA7	345.00 345KV CKT 1'	1195	0.21658	95.1	'DBL-WOOD-MED'		
FDNS	02G08110	2 11G	G10_008	'TO->FROM'	'NORTHWEST - TATONGA7	345.00 345KV CKT 1'	1195	0.21216	98	'DBL-WOOD-MED'		
FDNS	02G0847	0 11G	G10_008	'TO->FROM'	'NORTHWEST - TATONGA7	345.00 345KV CKT 1'	1195	0.21581	97.1	'DBL-WOOD-MED'		
FDNS	02G0847	2 11G	G10_008	'TO->FROM'	'NORTHWEST - TATONGA7	345.00 345KV CKT 1'	1195	0.2114	100	'DBL-WOOD-MED'		
FDNS	02G1007	2 11G	G10_008	'TO->FROM'	'NORTHWEST - TATONGA7	345.00 345KV CKT 1'	1195	0.21259	96.9	'DBL-WOOD-MED'		
FDNS	02G1014	0 11G	G10_008	'TO->FROM'	'NORTHWEST - TATONGA7	345.00 345KV CKT 1'	1195	0.21646	95.4	'DBL-WOOD-MED'		
FDNS	02G1014	2 11G	G10_008	'TO->FROM'	'NORTHWEST - TATONGA7	345.00 345KV CKT 1'	1195	0.21203	98.3	'DBL-WOOD-MED'		
FDNS	02G1014	2 11G	G10_008	'TO->FROM'	'NORTHWEST - TATONGA7	345.00 345KV CKT 1'	1195	0.21271	96.5	'DBL-WOOD-MED'		
FNSL-Itera 02ALL		0 11G	G10_008		Non Converged		0	0.17122	9999	'SPP-SWPS-03'		
FNSL-Itera 02ALL		0 11G	G10_008		Non Converged		0	0.12927	9999	'SPP-SWPS-03'		
FNSL-Itera 02ALL		0 11G	G10_008		Non Converged		0	0.11864	9999	'DBL-G0847-WO'		
FNSL-Itera 02ALL		0 11G	G10_008		Non Converged		0	0.09478	9999	'SPP-SWPS-03'		
FNSL-Itera 02ALL		0 11G	G10_008		Non Converged		0	0.08064	9999	'ATC_B2_8E2_G'		
FNSL-Itera 02ALL		0 11G	G10_008		Non Converged		0	0.07824	9999	'050 1'		
FNSL-Itera 02ALL		0 11G	G10_008		Non Converged		0	0.07558	9999	'ATC_B2_8E2'		
FNSL-Itera 02ALL		0 11G	G10_008		Non Converged		0	0.07389	9999	'050 2'		
FNSL-Itera 02ALL		0 11G	G10_008		Non Converged		0	0.07376	9999	'050 2'		
FNSL-Itera 02ALL		0 11G	G10_008		Non Converged		441	0.06345	56.34883	'STATELINE INTERCHANGE - STLN-DEMARC6230.00	230KV	CKT
FNSL-Blow 02ALL		0 11G	G10_008		Non Converged		72	0.05316	45.80798	'ALTUS JCT TAP - RUSSELL 138KV	CKT 1'	
FNSL-Itera 02ALL		0 11G	G10_008		Non Converged		0	0.05105	9999	'ATC_B2_8E2'		
FNSL-Itera 02ALL		0 11G	G10_008		Non Converged		0	0.04962	9999	'050 2'		
FNSL-Itera 02ALL		0 11G	G10_008		Non Converged		441	0.04144	56.87944	'STATELINE INTERCHANGE - STLN-DEMARC6230.00	230KV	CKT
FNSL-Itera 02ALL		0 11G	G10_008		Non Converged		0	0.03144	9999	'ATC_B2_8E2_G'		
FNSL-Itera 02ALL		0 11G	G10_008		Non Converged		0	0.02915	9999	'DBL-G0847-WO'		
FNSL-Itera 02ALL		0 11G	G10_008		Non Converged		0	0.02781	9999	'050 2'		
FNSL-Itera 02ALL		0 11G	G10_008		Non Converged		0	0.02346	9999	'ATC_B2_8E2_G'		
FNSL-Itera 02ALL		0 11G	G10_008		Non Converged		0	0.02235	9999	'050 1'		
FNSL-Itera 02ALL		0 11G	G10_008		Non Converged		441	0.02199	57.2667	'STLN-DEMARC6230.00 - SWEETWT6	230.00	230KV CKT 1'
FNSL-Blow 02ALL		0 11G	G10_008		Non Converged		1052	0.034	97.33807	'FINNEY SWITCHING STATION - STEVENSCO	345.00	345KV CK'
FNSL-Itera 02ALL		2 11G	G10_008		Non Converged		1052	0.04246	82.65054	'FINNEY SWITCHING STATION - STEVENSCO	345.00	345KV CK'
FNSL-Itera 02G1007		0 11G	G10_008		Non Converged		1052	0.04207	77.23053	'FINNEY SWITCHING STATION - STEVENSCO	345.00	345KV CK'
FNSL-Itera	2	0 11G	G10_008		Non Converged		1052	0.04219	76.82405	'FINNEY SWITCHING STATION - STEVENSCO	345.00	345KV CK'
FNSL-Blow 03ALL		0 11G	G10_008		Non Converged		0	0.13738	9999	'DBL-MEDLO-WI'		
FDNS	02ALL	0 11G	G10_009	'FROM->TO'	'FINNEY SWITCHING STATION - STEVENSCO	345.00	1052	0.26685	97.7	'HOLCOMB 115/22.0KV TRANSFORMER	CKT 1'	
FNSL-Itera 02ALL		0 11G	G10_009		Non Converged		0	0.17119	9999	'SPP-SWPS-03'		
FNSL-Itera 02ALL		0 11G	G10_009		Non Converged		0	0.12917	9999	'SPP-SWPS-03'		
FNSL-Itera 02ALL		0 11G	G10_009		Non Converged		0	0.11841	9999	'DBL-G0847-WO'		
FNSL-Itera 02ALL		0 11G	G10_009		Non Converged		0	0.09478	9999	'SPP-SWPS-03'		
FNSL-Itera 02ALL		0 11G	G10_009		Non Converged		0	0.08063	9999	'ATC_B2_8E2_G'		
FNSL-Itera 02ALL		0 11G	G10_009		Non Converged		0	0.07824	9999	'050 1'		
FNSL-Itera 02ALL		0 11G	G10_009		Non Converged		0	0.07557	9999	'ATC_B2_8E2'		
FNSL-Itera 02ALL		0 11G	G10_009		Non Converged		0	0.07389	9999	'050 2'		
FNSL-Itera 02ALL		0 11G	G10_009		Non Converged		0	0.07365	9999	'050 2'		
FNSL-Itera 02ALL		0 11G	G10_009		Non Converged		441	0.06339	56.55862	'STLN-DEMARC6230.00 - SWEETWT6	230.00	230KV CKT 1'
FNSL-Blow 02ALL		0 11G	G10_009		Non Converged		0	0.05292	9999	'050 1'		

SOLUTION GROUP	SCENARI	SEASON	SOURCE	DIRECTION	MONITORED ELEMENT	COMMON NAME	RATEB	TDF	TC%	LOAD	CONTINGENCY	NAME
FNSL-Itera 02ALL		0 11G	G10_009		Non Converged		0	0.05105	9999	'ATC_B2_8E2'		
FNSL-Itera 02ALL		0 11G	G10_009		Non Converged		0	0.04952	9999	'050 2'		
FNSL-Itera 02ALL		0 11G	G10_009		Non Converged		441	0.04142	56.82947	'STLN-DEMARC6230.00 - SWEETWT6	230.00	230KV CKT 1'
FNSL-Itera 02ALL		0 11G	G10_009		Non Converged		0	0.03143	9999	'ATC_B2_8E2_G'		
FNSL-Itera 02ALL		0 11G	G10_009		Non Converged		0	0.02905	9999	'ATC_B2_8E2'		
FNSL-Itera 02ALL		0 11G	G10_009		Non Converged		0	0.0278	9999	'050 2'		
FNSL-Itera 02ALL		0 11G	G10_009		Non Converged		0	0.02346	9999	'ATC_B2_8E2_G'		
FNSL-Itera 02ALL		0 11G	G10_009		Non Converged		0	0.02235	9999	'050 1'		
FNSL-Itera 02ALL		0 11G	G10_009		Non Converged		441	0.02199	57.2667	'STLN-DEMARC6230.00 - SWEETWT6	230.00	230KV CKT 1'
FNSL-Itera 00G10_00!		0 11WP	G10_009		Non Converged		0	0.03497	9999	'TRF-STEGALL'		
FNSL-Blow 00G10_00!		0 16SP	G10_009		Non Converged		0	0.03787	9999	'TRF-STEGALL'		
FNSL-Blow 00G10_00!		0 16WP	G10_009		Non Converged		0	0.03604	9999	'TRF-STEGALL'		
FNSL-Blow	0	0 16SP	G10_009		Non Converged		0	0.038	9999	'TRF-STEGALL'		
FNSL-Itera	0	0 11WP	G10_009		Non Converged		0	0.03518	9999	'TRF-STEGALL'		
FNSL-Blow	0	0 16WP	G10_009		Non Converged		0	0.03624	9999	'TRF-STEGALL'		
FNSL-Itera	1	0 11G	G10_009		Non Converged		0	0.03573	9999	'TRF-STEGALL'		
FNSL-Itera	1	2 11G	G10_009		Non Converged		0	0.03527	9999	'TRF-STEGALL'		
FNSL-Blow 02ALL		0 11G	G10_009		Non Converged		0	0.05071	9999	'DBL-HIT-G084'		
FNSL-Itera 02ALL		3 11G	G10_009		Non Converged		0	0.03263	9999	'TRF-STEGALL'		
FNSL-Blow 02G08110		0 11G	G10_009		Non Converged		0	0.04172	9999	'DBL-G0847-WO'		
FNSL-Itera 02G0847		0 11G	G10_009		Non Converged		0	0.04003	9999	'DBL-G0847-WO'		
FNSL-Itera 02G1007		0 11G	G10_009		Non Converged		0	0.04254	9999	'DBL-G0847-WO'		
FNSL-Itera 02G1014		0 11G	G10_009		Non Converged		0	0.04149	9999	'DBL-G0847-WO'		
FNSL-Blow	2	0 11G	G10_009		Non Converged		0	0.04273	9999	'DBL-G0847-WO'		
FNSL-Blow 03ALL		0 11G	G10_009		Non Converged		0	0.32482	9999	'DBL-SPRVL-CO'		
FNSL-Blow 03ALL		0 11G	G10_009		Non Converged		0	0.32482	9999	'DBL-COM-MEDL'		
FNSL-Blow 03ALL		0 11G	G10_009		Non Converged		0	0.21343	9999	'DBL-MEDLO-WI'		
FNSL-Itera	5	0 11G	G10_009		Non Converged		0	0.03567	9999	'TRF-STEGALL'		
FNSL-Itera	6	0 11G	G10_009		Non Converged		0	0.03604	9999	'TRF-STEGALL'		
FNSL-Itera	7	0 11G	G10_009		Non Converged		0	0.03623	9999	'TRF-STEGALL'		
FNSL-Itera	7	2 11G	G10_009		Non Converged		0	0.03623	9999	'TRF-STEGALL'		
FNSL-Itera	8	0 11G	G10_009		Non Converged		0	0.03643	9999	'TRF-STEGALL'		
FNSL-Itera	9	0 11G	G10_009		Non Converged		0	0.03735	9999	'TRF-STEGALL'		
FNSL-Itera	9	2 11G	G10_009		Non Converged		0	0.03735	9999	'TRF-STEGALL'		
FNSL-Itera	11	0 11G	G10_009		Non Converged		0	0.03586	9999	'TRF-STEGALL'		
FNSL-Itera	11	2 11G	G10_009		Non Converged		0	0.03586	9999	'TRF-STEGALL'		
FNSL-Itera	13	0 11G	G10_009		Non Converged		0	0.03688	9999	'TRF-STEGALL'		
FNSL-Itera	14	0 11G	G10_009		Non Converged		0	0.03649	9999	'TRF-STEGALL'		
FNSL-Itera	15	0 11G	G10_009		Non Converged		0	0.03644	9999	'TRF-STEGALL'		
FDNS	9	0 11G	G10_010	'TO->FROM'	'KELLY - MADISONCO	230.00 230KV CKT 1'	200	0.76725	127.2138	'BASE CASE'		
FDNS	9	0 11G	G10_010	'TO->FROM'	'FT RANDAL - MADISONCO	230.00 230KV CKT 1'	200	0.98857	162.2827	'KELLY - MADISONCO	230.00	230KV CKT 1'
FDNS	9	0 11G	G10_010	'TO->FROM'	'KELLY - MADISONCO	230.00 230KV CKT 1'	200	0.76725	125.7	'BLOOMFIELD - G07-11N9	115.00	115KV CKT 1'
FDNS	9	0 11G	G10_010	'TO->FROM'	'KELLY - MADISONCO	230.00 230KV CKT 1'	200	0.76803	124.9238	'AINSWORTH - AINSWORTH	115KV	CKT 1'
FDNS	9	0 11G	G10_010	'TO->FROM'	'KELLY - MADISONCO	230.00 230KV CKT 1'	200	0.75179	130.2414	'COLUMEAST - NW68TH & HOLDREGE	345KV	CKT 1'
FDNS	9	0 11G	G10_010	'TO->FROM'	'KELLY - MADISONCO	230.00 230KV CKT 1'	200	0.7587	124.6424	'COLUMEAST 230/115KV TRANSFORMER	CKT 1'	
FDNS	9	0 11G	G10_010	'TO->FROM'	'KELLY - MADISONCO	230.00 230KV CKT 1'	200	0.7587	124.6447	'COLUMEAST - KELLY	230KV	CKT 1'
FDNS	9	0 11G	G10_010	'TO->FROM'	'KELLY - MADISONCO	230.00 230KV CKT 1'	200	0.744	130.3588	'COLUMWEST - GRAND ISLAND	230KV	CKT 1'
FDNS	9	0 11G	G10_010	'TO->FROM'	'KELLY - MADISONCO	230.00 230KV CKT 1'	200	0.72635	119.7162	'KELLY - SHELL CREEK	230KV	CKT 1'
FDNS	9	0 11G	G10_010	'TO->FROM'	'KELLY - MADISONCO	230.00 230KV CKT 1'	200	0.76013	125.0899	'COLUMBUS - KELLY	115KV	CKT 1'
FDNS	9	0 11G	G10_010	'TO->FROM'	'KELLY - MADISONCO	230.00 230KV CKT 1'	200	0.76549	125.6072	'COLUMBUS - SCHUYLER	115KV	CKT 1'
FDNS	9	0 11G	G10_010	'TO->FROM'	'KELLY - MADISONCO	230.00 230KV CKT 1'	200	0.74968	117.7065	'HOSKINS - SHELL CREEK	345KV	CKT 1'
FDNS	9	0 11G	G10_010	'TO->FROM'	'KELLY - MADISONCO	230.00 230KV CKT 1'	200	0.76682	125.4529	'NELIGH - PETERSBURG	115KV	CKT 1'
FDNS	9	0 11G	G10_010	'TO->FROM'	'KELLY - MADISONCO	230.00 230KV CKT 1'	200	0.72635	119.7088	'SHELL CREEK 345/230KV TRANSFORMER	CKT 1'	
FDNS	9	0 11G	G10_010	'TO->FROM'	'KELLY - MADISONCO	230.00 230KV CKT 1'	200	0.76746	125.0806	'ATCHSNT3	345.00	- BOONEVILLE 345KV CKT 1'
FDNS	9	0 11G	G10_010	'TO->FROM'	'KELLY - MADISONCO	230.00 230KV CKT 1'	200	0.76852	120.8917	'RAUN - SIOUX CITY	345KV	CKT 1'
FDNS	9	0 11G	G10_010	'TO->FROM'	'KELLY - MADISONCO	230.00 230KV CKT 1'	200	0.7681	123.2956	'NUNDRWD - WAYSIDE	230KV	CKT 1'
FDNS	9	0 11G	G10_010	'TO->FROM'	'KELLY - MADISONCO	230.00 230KV CKT 1'	200	0.76784	123.7347	'STEGALL - WAYSIDE	230KV	CKT 1'
FDNS	9	0 11G	G10_010	'TO->FROM'	'KELLY - MADISONCO	230.00 230KV CKT 1'	200	0.76878	129.2914	'UTICA JCT - VFODNES	230KV	CKT 1'
FDNS	9	0 11G	G10_010	'TO->FROM'	'KELLY - MADISONCO	230.00 230KV CKT 1'	200	0.77655	135.694	'FT RANDAL - UTICA JCT	230KV	CKT 1'
FDNS	9	0 11G	G10_010	'TO->FROM'	'KELLY - MADISONCO	230.00 230KV CKT 1'	200	0.77407	133.218	'FT RANDAL - SIOUX CITY	230KV	CKT 1'
FDNS	9	0 11G	G10_010	'TO->FROM'	'KELLY - MADISONCO	230.00 230KV CKT 1'	200	0.76785	124.0883	'GAVINS POINT - YANKON	JCT	115KV CKT 1'
FDNS	9	0 11G	G10_010	'TO->FROM'	'KELLY - MADISONCO	230.00 230KV CKT 1'	200	0.76954	129.3441	'RASMUSN - UTICA JCT	230KV	CKT 1'
FDNS	9	0 11G	G10_010	'TO->FROM'	'KELLY - MADISONCO	230.00 230KV CKT 1'	200	0.76954	128.7668	'RASMUSN - SIOUX CITY	230KV	CKT 1'
FDNS	9	0 11G	G10_010	'TO->FROM'	'KELLY - MADISONCO	230.00 230KV CKT 1'	200	0.98857	160.2117	'FT RANDAL - MADISONCO	230.00	230KV CKT 1'
FDNS	9	0 11G	G10_010	'TO->FROM'	'KELLY - MADISONCO	230.00 230KV CKT 1'	200	0.76725	125.7	'G07-11N9	115.00	115/34.5KV TRANSFORMER CKT 1'
FDNS	9	0 11G	G10_010	'TO->FROM'	'KELLY - MADISONCO	230.00 230KV CKT 1'	200	0.76725	125.5	'BLOOMFIELD 115/34.5KV TRANSFORMER	CKT 1'	
FDNS	9	0 11G	G10_010	'TO->FROM'	'KELLY - MADISONCO	230.00 230KV CKT 1'	200	0.76727	125.2237	'BLOOMFIELD - GAVINS POINT	115KV	CKT 1'

SOLUTION GROUP	SCENARI	SEASON	SOURCE	DIRECTION	MONITORED ELEMENT	COMMON NAME	RATEB	TDF	TC%	LOAD	CONTINGENCY	NAME
FDNS	9	0 11G	G10_010	TO->FROM'	'KELLY - MADISONCO	230.00 230KV CKT 1'	200	0.76013	125.0901	'KELLY (KLYT1REG) 230/115/13.2KV TRANSFORMER CKT 1'		
FDNS	9	0 11G	G10_010	TO->FROM'	'KELLY - MADISONCO	230.00 230KV CKT 1'	200	0.76746	125.4561	'ATCHSNT3 345.00 - COOPER 345KV CKT 1'		
FDNS	9	0 11G	G10_010	TO->FROM'	'KELLY - MADISONCO	230.00 230KV CKT 1'	200	0.76725	125.7	'GERALD GENTLEMAN STATION 230/23.0KV TRANSFORMER CK		
FDNS	9	0 11G	G10_010	TO->FROM'	'KELLY - MADISONCO	230.00 230KV CKT 1'	200	0.7674	128.8223	'KEYSTONE - SIDNEY 345KV CKT 1'		
FDNS	9	0 11G	G10_010	TO->FROM'	'KELLY - MADISONCO	230.00 230KV CKT 1'	200	0.76943	125.0344	'RAUN - SUB 3451 FT CAL 345KV CKT 1'		
FDNS	9	0 11G	G10_010	TO->FROM'	'KELLY - MADISONCO	230.00 230KV CKT 1'	200	0.76962	125.6156	'FT THOMPSON - GRAND ISLAND 345KV CKT 1'		
FDNS	9	0 11G	G10_010	TO->FROM'	'KELLY - MADISONCO	230.00 230KV CKT 1'	200	0.76725	132.1	'COUNCIL BLUFFS 345/24.0KV TRANSFORMER CKT 1'		
FDNS	9	0 11G	G10_010	TO->FROM'	'KELLY - MADISONCO	230.00 230KV CKT 1'	200	0.76725	132.6	'COUNCIL BLUFFS 345/26.0KV TRANSFORMER CKT 1'		
FDNS	9	0 11G	G10_010	TO->FROM'	'KELLY - MADISONCO	230.00 230KV CKT 1'	200	0.7667	125.1144	'LAKEFIELD 3 - RAUN 345KV CKT 1'		
FDNS	9	0 11G	G10_010	TO->FROM'	'KELLY - MADISONCO	230.00 230KV CKT 1'	200	0.76725	123.7495	'FT RANDAL 230/13.8KV TRANSFORMER CKT 1'		
FDNS	9	0 11G	G10_010	TO->FROM'	'KELLY - MADISONCO	230.00 230KV CKT 1'	200	0.76725	125.4987	'FT RANDAL 230/13.8KV TRANSFORMER CKT 1'		
FDNS	9	0 11G	G10_010	TO->FROM'	'KELLY - MADISONCO	230.00 230KV CKT 1'	200	0.76725	124.9019	'FT RANDAL 115/13.8KV TRANSFORMER CKT 1'		
FDNS	9	0 11G	G10_010	TO->FROM'	'KELLY - MADISONCO	230.00 230KV CKT 1'	200	0.76725	128.7427	'LELAND OLDS 345/20.0KV TRANSFORMER CKT 1'		
FDNS	9	0 11G	G10_010	TO->FROM'	'KELLY - MADISONCO	230.00 230KV CKT 1'	200	0.76013	125.0899	'TRF-KELLY'		
FDNS	9	0 11G	G10_010	TO->FROM'	'KELLY - MADISONCO	230.00 230KV CKT 1'	200	0.77681	136.063	'DAK02WAPAB2'		
FDNS	9	0 11G	G10_010	TO->FROM'	'KELLY - MADISONCO	230.00 230KV CKT 1'	200	0.76725	129.0146	'GEN532751 1-WOLF CREEK GENERATING STATION UNIT 1'		
FDNS	9	0 11G	G10_010	TO->FROM'	'KELLY - MADISONCO	230.00 230KV CKT 1'	200	0.76725	129.7298	'GEN640009 1-COOPER NUCLEAR STATION'		
FDNS	9	0 11G	G10_010	TO->FROM'	'KELLY - MADISONCO	230.00 230KV CKT 1'	200	0.76725	129.3146	'GEN640028 1-COLUMCOGENERATION'		
FDNS	9	0 11G	G10_010	TO->FROM'	'KELLY - MADISONCO	230.00 230KV CKT 1'	200	0.76725	129.199	'GEN645011 1-NEBRASKA CITY 1'		
FDNS	9	0 11G	G10_010	TO->FROM'	'KELLY - MADISONCO	230.00 230KV CKT 1'	200	0.76725	129.5189	'GEN645012 2-NEBRASKA CITY 2'		
FDNS	9	0 11G	G10_010	TO->FROM'	'KELLY - MADISONCO	230.00 230KV CKT 1'	200	0.76725	127.2138	'BASE CASE'		
FDNS	9	0 11G	G10_010	TO->FROM'	'FT RANDAL - MADISONCO	230.00 230KV CKT 1'	200	0.98857	162.2827	'KELLY - MADISONCO 230.00 230KV CKT 1'		
FDNS	9	0 11G	G10_010	TO->FROM'	'KELLY - MADISONCO	230.00 230KV CKT 1'	200	0.76725	125.7	'BLOOMFIELD - G07-11N9 115.00 115KV CKT 1'		
FDNS	9	0 11G	G10_010	TO->FROM'	'KELLY - MADISONCO	230.00 230KV CKT 1'	200	0.76803	124.9238	'AINSWORTH - AINSWORTH 115KV CKT 1'		
FDNS	9	0 11G	G10_010	TO->FROM'	'KELLY - MADISONCO	230.00 230KV CKT 1'	200	0.75179	130.2414	'COLUMEAST - NW68TH & HOLDREGE 345KV CKT 1'		
FDNS	9	0 11G	G10_010	TO->FROM'	'KELLY - MADISONCO	230.00 230KV CKT 1'	200	0.7587	124.6424	'COLUMEAST 230/115KV TRANSFORMER CKT 1'		
FDNS	9	0 11G	G10_010	TO->FROM'	'KELLY - MADISONCO	230.00 230KV CKT 1'	200	0.7587	124.6447	'COLUMEAST - KELLY 230KV CKT 1'		
FDNS	9	0 11G	G10_010	TO->FROM'	'KELLY - MADISONCO	230.00 230KV CKT 1'	200	0.744	130.3588	'COLUMWEST - GRAND ISLAND 230KV CKT 1'		
FDNS	9	0 11G	G10_010	TO->FROM'	'KELLY - MADISONCO	230.00 230KV CKT 1'	200	0.72635	119.7162	'KELLY - SHELL CREEK 230KV CKT 1'		
FDNS	9	0 11G	G10_010	TO->FROM'	'KELLY - MADISONCO	230.00 230KV CKT 1'	200	0.76013	125.0899	'COLUMBUS - KELLY 115KV CKT 1'		
FDNS	9	0 11G	G10_010	TO->FROM'	'KELLY - MADISONCO	230.00 230KV CKT 1'	200	0.76549	125.6072	'COLUMBUS - SCHUYLER 115KV CKT 1'		
FDNS	9	0 11G	G10_010	TO->FROM'	'KELLY - MADISONCO	230.00 230KV CKT 1'	200	0.74968	117.7065	'HOSKINS - SHELL CREEK 345KV CKT 1'		
FDNS	9	0 11G	G10_010	TO->FROM'	'KELLY - MADISONCO	230.00 230KV CKT 1'	200	0.76682	125.4529	'NELIGH - PETERSBURG 115KV CKT 1'		
FDNS	9	0 11G	G10_010	TO->FROM'	'KELLY - MADISONCO	230.00 230KV CKT 1'	200	0.72635	119.7088	'SHELL CREEK 345/230KV TRANSFORMER CKT 1'		
FDNS	9	0 11G	G10_010	TO->FROM'	'KELLY - MADISONCO	230.00 230KV CKT 1'	200	0.76746	125.0806	'ATCHSNT3 345.00 - BOONEVILLE 345KV CKT 1'		
FDNS	9	0 11G	G10_010	TO->FROM'	'KELLY - MADISONCO	230.00 230KV CKT 1'	200	0.76852	120.8917	'RAUN - SIOUX CITY 345KV CKT 1'		
FDNS	9	0 11G	G10_010	TO->FROM'	'KELLY - MADISONCO	230.00 230KV CKT 1'	200	0.7681	123.2956	'NUNDRWD - WAYSIDE 230KV CKT 1'		
FDNS	9	0 11G	G10_010	TO->FROM'	'KELLY - MADISONCO	230.00 230KV CKT 1'	200	0.76784	123.7347	'STEGALL - WAYSIDE 230KV CKT 1'		
FDNS	9	0 11G	G10_010	TO->FROM'	'KELLY - MADISONCO	230.00 230KV CKT 1'	200	0.76878	129.2914	'UTICA JCT - VFODNES 230KV CKT 1'		
FDNS	9	0 11G	G10_010	TO->FROM'	'KELLY - MADISONCO	230.00 230KV CKT 1'	200	0.77655	135.694	'FT RANDAL - UTICA JCT 230KV CKT 1'		
FDNS	9	0 11G	G10_010	TO->FROM'	'KELLY - MADISONCO	230.00 230KV CKT 1'	200	0.77407	133.218	'FT RANDAL - SIOUX CITY 230KV CKT 1'		
FDNS	9	0 11G	G10_010	TO->FROM'	'KELLY - MADISONCO	230.00 230KV CKT 1'	200	0.76785	124.0883	'GAVINS POINT - YANKON JCT 115KV CKT 1'		
FDNS	9	0 11G	G10_010	TO->FROM'	'KELLY - MADISONCO	230.00 230KV CKT 1'	200	0.76954	129.3441	'RASMUSN - UTICA JCT 230KV CKT 1'		
FDNS	9	0 11G	G10_010	TO->FROM'	'KELLY - MADISONCO	230.00 230KV CKT 1'	200	0.76954	128.7668	'RASMUSN - SIOUX CITY 230KV CKT 1'		
FDNS	9	0 11G	G10_010	TO->FROM'	'KELLY - MADISONCO	230.00 230KV CKT 1'	200	0.98857	160.2117	'FT RANDAL - MADISONCO 230.00 230KV CKT 1'		
FDNS	9	0 11G	G10_010	TO->FROM'	'KELLY - MADISONCO	230.00 230KV CKT 1'	200	0.76725	125.7	'G07-11N9 115.00 115/34.5KV TRANSFORMER CKT 1'		
FDNS	9	0 11G	G10_010	TO->FROM'	'KELLY - MADISONCO	230.00 230KV CKT 1'	200	0.76725	125.5	'BLOOMFIELD 115/34.5KV TRANSFORMER CKT 1'		
FDNS	9	0 11G	G10_010	TO->FROM'	'KELLY - MADISONCO	230.00 230KV CKT 1'	200	0.76727	125.2237	'BLOOMFIELD - GAVINS POINT 115KV CKT 1'		
FDNS	9	0 11G	G10_010	TO->FROM'	'KELLY - MADISONCO	230.00 230KV CKT 1'	200	0.76013	125.0901	'KELLY (KLYT1REG) 230/115/13.2KV TRANSFORMER CKT 1'		
FDNS	9	0 11G	G10_010	TO->FROM'	'KELLY - MADISONCO	230.00 230KV CKT 1'	200	0.76746	125.4561	'ATCHSNT3 345.00 - COOPER 345KV CKT 1'		
FDNS	9	0 11G	G10_010	TO->FROM'	'KELLY - MADISONCO	230.00 230KV CKT 1'	200	0.76725	125.7	'GERALD GENTLEMAN STATION 230/23.0KV TRANSFORMER CK		
FDNS	9	0 11G	G10_010	TO->FROM'	'KELLY - MADISONCO	230.00 230KV CKT 1'	200	0.7674	128.8223	'KEYSTONE - SIDNEY 345KV CKT 1'		
FDNS	9	0 11G	G10_010	TO->FROM'	'KELLY - MADISONCO	230.00 230KV CKT 1'	200	0.76943	125.0344	'RAUN - SUB 3451 FT CAL 345KV CKT 1'		
FDNS	9	0 11G	G10_010	TO->FROM'	'KELLY - MADISONCO	230.00 230KV CKT 1'	200	0.76962	125.6156	'FT THOMPSON - GRAND ISLAND 345KV CKT 1'		
FDNS	9	0 11G	G10_010	TO->FROM'	'KELLY - MADISONCO	230.00 230KV CKT 1'	200	0.76725	132.1	'COUNCIL BLUFFS 345/24.0KV TRANSFORMER CKT 1'		
FDNS	9	0 11G	G10_010	TO->FROM'	'KELLY - MADISONCO	230.00 230KV CKT 1'	200	0.76725	132.6	'COUNCIL BLUFFS 345/26.0KV TRANSFORMER CKT 1'		
FDNS	9	0 11G	G10_010	TO->FROM'	'KELLY - MADISONCO	230.00 230KV CKT 1'	200	0.7667	125.1144	'LAKEFIELD 3 - RAUN 345KV CKT 1'		
FDNS	9	0 11G	G10_010	TO->FROM'	'KELLY - MADISONCO	230.00 230KV CKT 1'	200	0.76725	123.7495	'FT RANDAL 230/13.8KV TRANSFORMER CKT 1'		
FDNS	9	0 11G	G10_010	TO->FROM'	'KELLY - MADISONCO	230.00 230KV CKT 1'	200	0.76725	125.4987	'FT RANDAL 230/13.8KV TRANSFORMER CKT 1'		
FDNS	9	0 11G	G10_010	TO->FROM'	'KELLY - MADISONCO	230.00 230KV CKT 1'	200	0.76725	124.9019	'FT RANDAL 115/13.8KV TRANSFORMER CKT 1'		
FDNS	9	0 11G	G10_010	TO->FROM'	'KELLY - MADISONCO	230.00 230KV CKT 1'	200	0.76725	128.7427	'LELAND OLDS 345/20.0KV TRANSFORMER CKT 1'		
FDNS	9	0 11G	G10_010	TO->FROM'	'KELLY - MADISONCO	230.00 230KV CKT 1'	200	0.76013	125.0899	'TRF-KELLY'		
FDNS	9	0 11G	G10_010	TO->FROM'	'KELLY - MADISONCO	230.00 230KV CKT 1'	200	0.77681	136.063	'DAK02WAPAB2'		
FDNS	9	0 11G	G10_010	TO->FROM'	'KELLY - MADISONCO	230.00 230KV CKT 1'	200	0.76725	129.0146	'GEN532751 1-WOLF CREEK GENERATING STATION UNIT 1'		
FDNS	9	0 11G	G10_010	TO->FROM'	'KELLY - MADISONCO	230.00 230KV CKT 1'	200	0.76725	129.7298	'GEN640009 1-COOPER NUCLEAR STATION'		
FDNS	9	0 11G	G10_010	TO->FROM'	'KELLY - MADISONCO	230.00 230KV CKT 1'	200	0.76725	129.3146	'GEN640028 1-COLUMCOGENERATION'		
FDNS	9	0 11G	G10_010	TO->FROM'	'KELLY - MADISONCO	230.00 230KV CKT 1'	200	0.76725	129.199	'GEN645011 1-NEBRASKA CITY 1'		

SOLUTION GROUP	SCENARIO	SEASON	SOURCE	DIRECTION	MONITORED ELEMENT	COMMON NAME	RATEB	TDF	TC%	LOAD	CONTINGENCY NAME
FDNS		9	0 11G	G10_010	TO->FROM	'KELLY - MADISONCO 230.00 230KV CKT 1'	200	0.76725	129.5189	'GEN645012 2-NEBRASKA CITY 2'	
FDNS	00G10_010	0 11SP	G10_010	TO->FROM	'KELLY - MADISONCO 230.00 230KV CKT 1'	200	0.77472	100.9894	'ONEILL - SPENCER 115KV CKT 1'		
FDNS	00G10_010	0 11SP	G10_010	TO->FROM	'KELLY - MADISONCO 230.00 230KV CKT 1'	200	0.783	109.8358	'FT RANDAL - UTICA JCT 230KV CKT 1'		
FDNS	00G10_010	0 11SP	G10_010	TO->FROM	'KELLY - MADISONCO 230.00 230KV CKT 1'	200	0.78059	104.8072	'FT RANDAL - SIOUX CITY 230KV CKT 1'		
FDNS	00G10_010	0 11SP	G10_010	TO->FROM	'KELLY - MADISONCO 230.00 230KV CKT 1'	200	0.76442	102.1699	'HOSKINS - RAUN 345KV CKT 1'		
FDNS	00G10_010	0 11SP	G10_010	TO->FROM	'KELLY - MADISONCO 230.00 230KV CKT 1'	200	0.77472	101.2614	'FT RANDAL - SPENCER 115KV CKT 1'		
FDNS	00G10_010	0 11SP	G10_010	TO->FROM	'KELLY - MADISONCO 230.00 230KV CKT 1'	200	0.77607	106.3869	'FT THOMPSON - GRAND ISLAND 345KV CKT 1'		
FDNS	00G10_010	0 11SP	G10_010	TO->FROM	'KELLY - MADISONCO 230.00 230KV CKT 1'	200	0.77366	100.7	'COUNCIL BLUFFS 345/24.0KV TRANSFORMER CKT 1'		
FDNS	00G10_010	0 11SP	G10_010	TO->FROM	'KELLY - MADISONCO 230.00 230KV CKT 1'	200	0.77366	101.2	'COUNCIL BLUFFS 345/26.0KV TRANSFORMER CKT 1'		
FDNS	00G10_010	0 11SP	G10_010	TO->FROM	'KELLY - MADISONCO 230.00 230KV CKT 1'	200	0.77472	101.3072	'LN-WAPA6'		
FDNS	00G10_010	0 11SP	G10_010	TO->FROM	'KELLY - MADISONCO 230.00 230KV CKT 1'	200	0.7635	100.5496	'TRF-HOSKINS'		
FDNS	00G10_010	0 11SP	G10_010	TO->FROM	'KELLY - MADISONCO 230.00 230KV CKT 1'	200	0.78329	109.8629	'DAK02WAPAB2'		
FDNS	00G10_010	0 11SP	G10_010	TO->FROM	'KELLY - MADISONCO 230.00 230KV CKT 1'	200	0.77472	101.3072	'NEB001NPPB2'		
FDNS	00G10_010	0 11SP	G10_010	TO->FROM	'KELLY - MADISONCO 230.00 230KV CKT 1'	200	0.77366	100.916	'GEN532751 1-WOLF CREEK GENERATING STATION UNIT 1'		
FDNS	00G10_010	0 11SP	G10_010	TO->FROM	'KELLY - MADISONCO 230.00 230KV CKT 1'	200	0.77366	100.3122	'GEN640009 1-COOPER NUCLEAR STATION'		
FDNS	00G10_010	0 16SP	G10_010	TO->FROM	'KELLY - MADISONCO 230.00 230KV CKT 1'	200	0.75657	101.2819	'COLUMEAST - NW68TH & HOLDREGE 345KV CKT 1'		
FDNS	00G10_010	0 16SP	G10_010	TO->FROM	'KELLY - MADISONCO 230.00 230KV CKT 1'	200	0.74888	100.8753	'COLUMWEST - GRAND ISLAND 230KV CKT 1'		
FDNS	00G10_010	0 16SP	G10_010	TO->FROM	'KELLY - MADISONCO 230.00 230KV CKT 1'	200	0.77345	103.9416	'ONEILL - SPENCER 115KV CKT 1'		
FDNS	00G10_010	0 16SP	G10_010	TO->FROM	'KELLY - MADISONCO 230.00 230KV CKT 1'	200	0.78165	112.0147	'FT RANDAL - UTICA JCT 230KV CKT 1'		
FDNS	00G10_010	0 16SP	G10_010	TO->FROM	'KELLY - MADISONCO 230.00 230KV CKT 1'	200	0.77919	106.7253	'FT RANDAL - SIOUX CITY 230KV CKT 1'		
FDNS	00G10_010	0 16SP	G10_010	TO->FROM	'KELLY - MADISONCO 230.00 230KV CKT 1'	200	0.77469	100.3798	'RASMUSN - UTICA JCT 230KV CKT 1'		
FDNS	00G10_010	0 16SP	G10_010	TO->FROM	'KELLY - MADISONCO 230.00 230KV CKT 1'	200	0.77245	100.0877	'GAVINS POINT - HARTINGTON 115KV CKT 1'		
FDNS	00G10_010	0 16SP	G10_010	TO->FROM	'KELLY - MADISONCO 230.00 230KV CKT 1'	200	0.76294	104.8665	'HOSKINS - RAUN 345KV CKT 1'		
FDNS	00G10_010	0 16SP	G10_010	TO->FROM	'KELLY - MADISONCO 230.00 230KV CKT 1'	200	0.77345	104.2125	'FT RANDAL - SPENCER 115KV CKT 1'		
FDNS	00G10_010	0 16SP	G10_010	TO->FROM	'KELLY - MADISONCO 230.00 230KV CKT 1'	200	0.77083	100.4128	'SIOUX CITY - TWIN CHURCH 230KV CKT 1'		
FDNS	00G10_010	0 16SP	G10_010	TO->FROM	'KELLY - MADISONCO 230.00 230KV CKT 1'	200	0.77438	109.1732	'FT THOMPSON - GRAND ISLAND 345KV CKT 1'		
FDNS	00G10_010	0 16SP	G10_010	TO->FROM	'KELLY - MADISONCO 230.00 230KV CKT 1'	200	0.77242	102.4	'COUNCIL BLUFFS 345/24.0KV TRANSFORMER CKT 1'		
FDNS	00G10_010	0 16SP	G10_010	TO->FROM	'KELLY - MADISONCO 230.00 230KV CKT 1'	200	0.77242	102.9	'COUNCIL BLUFFS 345/26.0KV TRANSFORMER CKT 1'		
FDNS	00G10_010	0 16SP	G10_010	TO->FROM	'KELLY - MADISONCO 230.00 230KV CKT 1'	200	0.77345	104.2574	'LN-WAPA6'		
FDNS	00G10_010	0 16SP	G10_010	TO->FROM	'KELLY - MADISONCO 230.00 230KV CKT 1'	200	0.76207	103.2594	'TRF-HOSKINS'		
FDNS	00G10_010	0 16SP	G10_010	TO->FROM	'KELLY - MADISONCO 230.00 230KV CKT 1'	200	0.78196	111.9673	'DAK02WAPAB2'		
FDNS	00G10_010	0 16SP	G10_010	TO->FROM	'KELLY - MADISONCO 230.00 230KV CKT 1'	200	0.77345	104.2574	'NEB001NPPB2'		
FDNS	00G10_010	0 16SP	G10_010	TO->FROM	'KELLY - MADISONCO 230.00 230KV CKT 1'	200	0.77245	100.3465	'NEB02WAPAB2'		
FDNS	00G10_010	0 16SP	G10_010	TO->FROM	'KELLY - MADISONCO 230.00 230KV CKT 1'	200	0.77242	100	'GEN335831 1-RIVERBEND UNIT#1'		
FDNS	00G10_010	0 16SP	G10_010	TO->FROM	'KELLY - MADISONCO 230.00 230KV CKT 1'	200	0.77242	100.3368	'GEN336153 1-WATERFORD UNIT#3'		
FDNS	00G10_010	0 16SP	G10_010	TO->FROM	'KELLY - MADISONCO 230.00 230KV CKT 1'	200	0.77242	100.5769	'GEN336821 1-GRAND GULF UNIT'		
FDNS	00G10_010	0 16SP	G10_010	TO->FROM	'KELLY - MADISONCO 230.00 230KV CKT 1'	200	0.77242	100.069	'GEN337910 1-ARKANSAS NUCLEAR ONE UNIT #1'		
FDNS	00G10_010	0 16SP	G10_010	TO->FROM	'KELLY - MADISONCO 230.00 230KV CKT 1'	200	0.77242	100.5236	'GEN337911 1-ARKANSAS NUCLEAR ONE UNIT #2'		
FDNS	00G10_010	0 16SP	G10_010	TO->FROM	'KELLY - MADISONCO 230.00 230KV CKT 1'	200	0.77242	100.0698	'GEN514805 1-SOONER UNIT 1'		
FDNS	00G10_010	0 16SP	G10_010	TO->FROM	'KELLY - MADISONCO 230.00 230KV CKT 1'	200	0.77242	100.0733	'GEN514806 1-SOONER UNIT 2'		
FDNS	00G10_010	0 16SP	G10_010	TO->FROM	'KELLY - MADISONCO 230.00 230KV CKT 1'	200	0.77242	100.173	'GEN525562 1-TOLK GEN #2 24 KV'		
FDNS	00G10_010	0 16SP	G10_010	TO->FROM	'KELLY - MADISONCO 230.00 230KV CKT 1'	200	0.77242	101.3132	'GEN532651 1-JEFFREY ENERGY CENTER UNIT 1'		
FDNS	00G10_010	0 16SP	G10_010	TO->FROM	'KELLY - MADISONCO 230.00 230KV CKT 1'	200	0.77242	101.2845	'GEN532652 1-JEFFREY ENERGY CENTER UNIT 2'		
FDNS	00G10_010	0 16SP	G10_010	TO->FROM	'KELLY - MADISONCO 230.00 230KV CKT 1'	200	0.77242	100.279	'GEN532653 1-JEFFREY ENERGY CENTER UNIT 3'		
FDNS	00G10_010	0 16SP	G10_010	TO->FROM	'KELLY - MADISONCO 230.00 230KV CKT 1'	200	0.77242	103.314	'GEN532751 1-WOLF CREEK GENERATING STATION UNIT 1'		
FDNS	00G10_010	0 16SP	G10_010	TO->FROM	'KELLY - MADISONCO 230.00 230KV CKT 1'	200	0.77242	100.6085	'GEN542951 5-HAWTHORN UNIT #5'		
FDNS	00G10_010	0 16SP	G10_010	TO->FROM	'KELLY - MADISONCO 230.00 230KV CKT 1'	200	0.77242	101.2874	'GEN542955 1-LACYGNE UNIT #1'		
FDNS	00G10_010	0 16SP	G10_010	TO->FROM	'KELLY - MADISONCO 230.00 230KV CKT 1'	200	0.77242	100.9194	'GEN542956 2-LACYGNE UNIT #2'		
FDNS	00G10_010	0 16SP	G10_010	TO->FROM	'KELLY - MADISONCO 230.00 230KV CKT 1'	200	0.77242	101.58	'GEN542957 1-IATAN UNIT #1'		
FDNS	00G10_010	0 16SP	G10_010	TO->FROM	'KELLY - MADISONCO 230.00 230KV CKT 1'	200	0.77242	102.2933	'GEN542962 2-IATAN UNIT #2'		
FDNS	00G10_010	0 16SP	G10_010	TO->FROM	'KELLY - MADISONCO 230.00 230KV CKT 1'	200	0.77242	103.431	'GEN640009 1-COOPER NUCLEAR STATION'		
FDNS	00G10_010	0 16SP	G10_010	TO->FROM	'KELLY - MADISONCO 230.00 230KV CKT 1'	200	0.77242	101.8893	'GEN640010 1-GERALD GENTLEMAN STATION UNIT 1'		
FDNS	00G10_010	0 16SP	G10_010	TO->FROM	'KELLY - MADISONCO 230.00 230KV CKT 1'	200	0.77242	101.345	'GEN640011 2-GERALD GENTLEMAN STATION UNIT 2'		
FDNS	00G10_010	0 16SP	G10_010	TO->FROM	'KELLY - MADISONCO 230.00 230KV CKT 1'	200	0.77242	100.1277	'GEN641089 2-ENERGY CENTER 2'		
FDNS	00G10_010	0 16SP	G10_010	TO->FROM	'KELLY - MADISONCO 230.00 230KV CKT 1'	200	0.77242	100.5875	'GEN645001 1-FORT CALHOUN 1'		
FDNS	00G10_010	0 16SP	G10_010	TO->FROM	'KELLY - MADISONCO 230.00 230KV CKT 1'	200	0.77242	102.3772	'GEN645011 1-NEBRASKA CITY 1'		
FDNS	00G10_010	0 16SP	G10_010	TO->FROM	'KELLY - MADISONCO 230.00 230KV CKT 1'	200	0.77242	102.6251	'GEN645012 2-NEBRASKA CITY 2'		
FDNS	00G10_010	0 11SP	G10_010	TO->FROM	'KELLY - MADISONCO 230.00 230KV CKT 1'	200	0.77472	100.9894	'ONEILL - SPENCER 115KV CKT 1'		
FDNS	00G10_010	0 11SP	G10_010	TO->FROM	'KELLY - MADISONCO 230.00 230KV CKT 1'	200	0.783	109.8358	'FT RANDAL - UTICA JCT 230KV CKT 1'		
FDNS	00G10_010	0 11SP	G10_010	TO->FROM	'KELLY - MADISONCO 230.00 230KV CKT 1'	200	0.78059	104.8072	'FT RANDAL - SIOUX CITY 230KV CKT 1'		
FDNS	00G10_010	0 11SP	G10_010	TO->FROM	'KELLY - MADISONCO 230.00 230KV CKT 1'	200	0.76442	102.1699	'HOSKINS - RAUN 345KV CKT 1'		
FDNS	00G10_010	0 11SP	G10_010	TO->FROM	'KELLY - MADISONCO 230.00 230KV CKT 1'	200	0.77472	101.2614	'FT RANDAL - SPENCER 115KV CKT 1'		
FDNS	00G10_010	0 11SP	G10_010	TO->FROM	'KELLY - MADISONCO 230.00 230KV CKT 1'	200	0.77607	106.3869	'FT THOMPSON - GRAND ISLAND 345KV CKT 1'		
FDNS	00G10_010	0 11SP	G10_010	TO->FROM	'KELLY - MADISONCO 230.00 230KV CKT 1'	200	0.77366	100.7	'COUNCIL BLUFFS 345/24.0KV TRANSFORMER CKT 1'		
FDNS	00G10_010	0 11SP	G10_010	TO->FROM	'KELLY - MADISONCO 230.00 230KV CKT 1'	200	0.77366	101.2	'COUNCIL BLUFFS 345/26.0KV TRANSFORMER CKT 1'		
FDNS	00G10_010	0 11SP	G10_010	TO->FROM	'KELLY - MADISONCO 230.00 230KV CKT 1'	200	0.77472	101.3072	'LN-WAPA6'		
FDNS	00G10_010	0 11SP	G10_010	TO->FROM	'KELLY - MADISONCO 230.00 230KV CKT 1'	200	0.7635	100.5496	'TRF-HOSKINS'		

SOLUTION GROUP	SCENARIO	SEASON	SOURCE	DIRECTION	MONITORED ELEMENT	COMMON NAME	RATEB	TDF	TC%	LOAD	CONTINGENCY	NAME
FDNS	00G10_01	0 11SP	G10_010	TO->FROM'	'KELLY - MADISONCO	230.00 230KV CKT 1'	200	0.78329	109.8629			'DAK02WAPAB2'
FDNS	00G10_01	0 11SP	G10_010	TO->FROM'	'KELLY - MADISONCO	230.00 230KV CKT 1'	200	0.77472	101.3072			'NEB001NPPB2'
FDNS	00G10_01	0 11SP	G10_010	TO->FROM'	'KELLY - MADISONCO	230.00 230KV CKT 1'	200	0.77366	100.916			'GEN532751 1-WOLF CREEK GENERATING STATION UNIT 1'
FDNS	00G10_01	0 11SP	G10_010	TO->FROM'	'KELLY - MADISONCO	230.00 230KV CKT 1'	200	0.77366	100.3122			'GEN640009 1-COOPER NUCLEAR STATION'
FDNS	00G10_01	0 16SP	G10_010	TO->FROM'	'KELLY - MADISONCO	230.00 230KV CKT 1'	200	0.75657	101.2819			'COLUMEAST - NW68TH & HOLDREGE 345KV CKT 1'
FDNS	00G10_01	0 16SP	G10_010	TO->FROM'	'KELLY - MADISONCO	230.00 230KV CKT 1'	200	0.74888	100.8753			'COLUMWEST - GRAND ISLAND 230KV CKT 1'
FDNS	00G10_01	0 16SP	G10_010	TO->FROM'	'KELLY - MADISONCO	230.00 230KV CKT 1'	200	0.77345	103.9416			'ONEILL - SPENCER 115KV CKT 1'
FDNS	00G10_01	0 16SP	G10_010	TO->FROM'	'KELLY - MADISONCO	230.00 230KV CKT 1'	200	0.78165	112.0147			'FT RANDAL - UTICA JCT 230KV CKT 1'
FDNS	00G10_01	0 16SP	G10_010	TO->FROM'	'KELLY - MADISONCO	230.00 230KV CKT 1'	200	0.77919	106.7253			'FT RANDAL - SIOUX CITY 230KV CKT 1'
FDNS	00G10_01	0 16SP	G10_010	TO->FROM'	'KELLY - MADISONCO	230.00 230KV CKT 1'	200	0.77469	100.3798			'RASMUSN - UTICA JCT 230KV CKT 1'
FDNS	00G10_01	0 16SP	G10_010	TO->FROM'	'KELLY - MADISONCO	230.00 230KV CKT 1'	200	0.77245	100.0877			'GAVINS POINT - HARTINGTON 115KV CKT 1'
FDNS	00G10_01	0 16SP	G10_010	TO->FROM'	'KELLY - MADISONCO	230.00 230KV CKT 1'	200	0.76294	104.8665			'HOSKINS - RAUN 345KV CKT 1'
FDNS	00G10_01	0 16SP	G10_010	TO->FROM'	'KELLY - MADISONCO	230.00 230KV CKT 1'	200	0.77345	104.2125			'FT RANDAL - SPENCER 115KV CKT 1'
FDNS	00G10_01	0 16SP	G10_010	TO->FROM'	'KELLY - MADISONCO	230.00 230KV CKT 1'	200	0.77083	100.4128			'SIOUX CITY - TWIN CHURCH 230KV CKT 1'
FDNS	00G10_01	0 16SP	G10_010	TO->FROM'	'KELLY - MADISONCO	230.00 230KV CKT 1'	200	0.77438	109.1732			'FT THOMPSON - GRAND ISLAND 345KV CKT 1'
FDNS	00G10_01	0 16SP	G10_010	TO->FROM'	'KELLY - MADISONCO	230.00 230KV CKT 1'	200	0.77242	102.4			'COUNCIL BLUFFS 345/24.0KV TRANSFORMER CKT 1'
FDNS	00G10_01	0 16SP	G10_010	TO->FROM'	'KELLY - MADISONCO	230.00 230KV CKT 1'	200	0.77242	102.9			'COUNCIL BLUFFS 345/26.0KV TRANSFORMER CKT 1'
FDNS	00G10_01	0 16SP	G10_010	TO->FROM'	'KELLY - MADISONCO	230.00 230KV CKT 1'	200	0.77345	104.2574			'LN-WAPAB6'
FDNS	00G10_01	0 16SP	G10_010	TO->FROM'	'KELLY - MADISONCO	230.00 230KV CKT 1'	200	0.76207	103.2594			'TRF-HOSKINS'
FDNS	00G10_01	0 16SP	G10_010	TO->FROM'	'KELLY - MADISONCO	230.00 230KV CKT 1'	200	0.78196	111.9673			'DAK02WAPAB2'
FDNS	00G10_01	0 16SP	G10_010	TO->FROM'	'KELLY - MADISONCO	230.00 230KV CKT 1'	200	0.77345	104.2574			'NEB001NPPB2'
FDNS	00G10_01	0 16SP	G10_010	TO->FROM'	'KELLY - MADISONCO	230.00 230KV CKT 1'	200	0.77245	100.3465			'NEB02WAPAB2'
FDNS	00G10_01	0 16SP	G10_010	TO->FROM'	'KELLY - MADISONCO	230.00 230KV CKT 1'	200	0.77242	100			'GEN335831 1-RIVERBEND UNIT#1'
FDNS	00G10_01	0 16SP	G10_010	TO->FROM'	'KELLY - MADISONCO	230.00 230KV CKT 1'	200	0.77242	100.3368			'GEN336153 1-WATERFORD UNIT#3'
FDNS	00G10_01	0 16SP	G10_010	TO->FROM'	'KELLY - MADISONCO	230.00 230KV CKT 1'	200	0.77242	100.5769			'GEN336821 1-GRAND GULF UNIT'
FDNS	00G10_01	0 16SP	G10_010	TO->FROM'	'KELLY - MADISONCO	230.00 230KV CKT 1'	200	0.77242	100.069			'GEN337910 1-ARKANSAS NUCLEAR ONE UNIT #1'
FDNS	00G10_01	0 16SP	G10_010	TO->FROM'	'KELLY - MADISONCO	230.00 230KV CKT 1'	200	0.77242	100.5236			'GEN337911 1-ARKANSAS NUCLEAR ONE UNIT #2'
FDNS	00G10_01	0 16SP	G10_010	TO->FROM'	'KELLY - MADISONCO	230.00 230KV CKT 1'	200	0.77242	100.0698			'GEN514805 1-SOONER UNIT 1'
FDNS	00G10_01	0 16SP	G10_010	TO->FROM'	'KELLY - MADISONCO	230.00 230KV CKT 1'	200	0.77242	100.0733			'GEN514806 1-SOONER UNIT 2'
FDNS	00G10_01	0 16SP	G10_010	TO->FROM'	'KELLY - MADISONCO	230.00 230KV CKT 1'	200	0.77242	100.173			'GEN525562 1-TOLK GEN #2 24 KV'
FDNS	00G10_01	0 16SP	G10_010	TO->FROM'	'KELLY - MADISONCO	230.00 230KV CKT 1'	200	0.77242	101.3132			'GEN532651 1-JEFFREY ENERGY CENTER UNIT 1'
FDNS	00G10_01	0 16SP	G10_010	TO->FROM'	'KELLY - MADISONCO	230.00 230KV CKT 1'	200	0.77242	101.2845			'GEN532652 1-JEFFREY ENERGY CENTER UNIT 2'
FDNS	00G10_01	0 16SP	G10_010	TO->FROM'	'KELLY - MADISONCO	230.00 230KV CKT 1'	200	0.77242	100.279			'GEN532653 1-JEFFREY ENERGY CENTER UNIT 3'
FDNS	00G10_01	0 16SP	G10_010	TO->FROM'	'KELLY - MADISONCO	230.00 230KV CKT 1'	200	0.77242	103.314			'GEN532751 1-WOLF CREEK GENERATING STATION UNIT 1'
FDNS	00G10_01	0 16SP	G10_010	TO->FROM'	'KELLY - MADISONCO	230.00 230KV CKT 1'	200	0.77242	100.6085			'GEN542951 5-HAWTHORN UNIT #5'
FDNS	00G10_01	0 16SP	G10_010	TO->FROM'	'KELLY - MADISONCO	230.00 230KV CKT 1'	200	0.77242	101.2874			'GEN542955 1-LACYGNE UNIT #1'
FDNS	00G10_01	0 16SP	G10_010	TO->FROM'	'KELLY - MADISONCO	230.00 230KV CKT 1'	200	0.77242	100.9194			'GEN542956 2-LACYGNE UNIT #2'
FDNS	00G10_01	0 16SP	G10_010	TO->FROM'	'KELLY - MADISONCO	230.00 230KV CKT 1'	200	0.77242	101.58			'GEN542957 1-IATAN UNIT #1'
FDNS	00G10_01	0 16SP	G10_010	TO->FROM'	'KELLY - MADISONCO	230.00 230KV CKT 1'	200	0.77242	102.2933			'GEN542962 2-IATAN UNIT #2'
FDNS	00G10_01	0 16SP	G10_010	TO->FROM'	'KELLY - MADISONCO	230.00 230KV CKT 1'	200	0.77242	103.431			'GEN640009 1-COOPER NUCLEAR STATION'
FDNS	00G10_01	0 16SP	G10_010	TO->FROM'	'KELLY - MADISONCO	230.00 230KV CKT 1'	200	0.77242	101.8893			'GEN640010 1-GERALD GENTLEMAN STATION UNIT 1'
FDNS	00G10_01	0 16SP	G10_010	TO->FROM'	'KELLY - MADISONCO	230.00 230KV CKT 1'	200	0.77242	101.345			'GEN640011 2-GERALD GENTLEMAN STATION UNIT 2'
FDNS	00G10_01	0 16SP	G10_010	TO->FROM'	'KELLY - MADISONCO	230.00 230KV CKT 1'	200	0.77242	100.1277			'GEN641089 2-ENERGY CENTER 2'
FDNS	00G10_01	0 16SP	G10_010	TO->FROM'	'KELLY - MADISONCO	230.00 230KV CKT 1'	200	0.77242	100.5875			'GEN645001 1-FORT CALHOUN 1'
FDNS	00G10_01	0 16SP	G10_010	TO->FROM'	'KELLY - MADISONCO	230.00 230KV CKT 1'	200	0.77242	102.3772			'GEN645011 1-NEBRASKA CITY 1'
FDNS	00G10_01	0 16SP	G10_010	TO->FROM'	'KELLY - MADISONCO	230.00 230KV CKT 1'	200	0.77242	102.6251			'GEN645012 2-NEBRASKA CITY 2'
FDNS	09G1010	0 11G	G10_010	TO->FROM'	'KELLY - MADISONCO	230.00 230KV CKT 1'	200	0.76669	135.0563			'BASE CASE'
FDNS	09G1010	0 11G	G10_010	TO->FROM'	'KELLY - MADISONCO	230.00 230KV CKT 1'	200	0.76669	103.8			'G06-44N2 230.00 - MADISONCO 230.00 230KV CKT 1'
FDNS	09G1010	0 11G	G10_010	TO->FROM'	'FT RANDAL - MADISONCO	230.00 230KV CKT 1'	200	0.98786	174.1864			'KELLY - MADISONCO 230.00 230KV CKT 1'
FDNS	09G1010	0 11G	G10_010	TO->FROM'	'KELLY - MADISONCO	230.00 230KV CKT 1'	200	0.76669	133.5			'BLOOMFIELD - G07-11N9 115.00 115KV CKT 1'
FDNS	09G1010	0 11G	G10_010	TO->FROM'	'KELLY - MADISONCO	230.00 230KV CKT 1'	200	0.76748	132.7652			'AINSWORTH - AINSWORTH 115KV CKT 1'
FDNS	09G1010	0 11G	G10_010	TO->FROM'	'KELLY - MADISONCO	230.00 230KV CKT 1'	200	0.75124	137.8374			'COLUMEAST - NW68TH & HOLDREGE 345KV CKT 1'
FDNS	09G1010	0 11G	G10_010	TO->FROM'	'KELLY - MADISONCO	230.00 230KV CKT 1'	200	0.75815	132.3943			'COLUMEAST 230/115KV TRANSFORMER CKT 1'
FDNS	09G1010	0 11G	G10_010	TO->FROM'	'KELLY - MADISONCO	230.00 230KV CKT 1'	200	0.75815	132.3936			'COLUMEAST - KELLY 230KV CKT 1'
FDNS	09G1010	0 11G	G10_010	TO->FROM'	'KELLY - MADISONCO	230.00 230KV CKT 1'	200	0.74346	138.0364			'COLUMWEST - GRAND ISLAND 230KV CKT 1'
FDNS	09G1010	0 11G	G10_010	TO->FROM'	'KELLY - MADISONCO	230.00 230KV CKT 1'	200	0.72582	127.2682			'KELLY - SHELL CREEK 230KV CKT 1'
FDNS	09G1010	0 11G	G10_010	TO->FROM'	'KELLY - MADISONCO	230.00 230KV CKT 1'	200	0.75958	132.8568			'COLUMBUS - KELLY 115KV CKT 1'
FDNS	09G1010	0 11G	G10_010	TO->FROM'	'KELLY - MADISONCO	230.00 230KV CKT 1'	200	0.76494	133.4363			'COLUMBUS - SCHUYLER 115KV CKT 1'
FDNS	09G1010	0 11G	G10_010	TO->FROM'	'KELLY - MADISONCO	230.00 230KV CKT 1'	200	0.74913	125.365			'HOSKINS - SHELL CREEK 345KV CKT 1'
FDNS	09G1010	0 11G	G10_010	TO->FROM'	'KELLY - MADISONCO	230.00 230KV CKT 1'	200	0.76626	133.2986			'NELIGH - PETERSBURG 115KV CKT 1'
FDNS	09G1010	0 11G	G10_010	TO->FROM'	'KELLY - MADISONCO	230.00 230KV CKT 1'	200	0.72582	127.2209			'SHELL CREEK 345/230KV TRANSFORMER CKT 1'
FDNS	09G1010	0 11G	G10_010	TO->FROM'	'KELLY - MADISONCO	230.00 230KV CKT 1'	200	0.76691	132.9005			'ATCHSNT3 345.00 - BOONEVILLE 345KV CKT 1'
FDNS	09G1010	0 11G	G10_010	TO->FROM'	'KELLY - MADISONCO	230.00 230KV CKT 1'	200	0.76796	128.734			'RAUN - SIOUX CITY 345KV CKT 1'
FDNS	09G1010	0 11G	G10_010	TO->FROM'	'KELLY - MADISONCO	230.00 230KV CKT 1'	200	0.76754	131.1253			'NUNDRWD - WAYSIDE 230KV CKT 1'
FDNS	09G1010	0 11G	G10_010	TO->FROM'	'KELLY - MADISONCO	230.00 230KV CKT 1'	200	0.76729	131.5573			'STEGALL - WAYSIDE 230KV CKT 1'
FDNS	09G1010	0 11G	G10_010	TO->FROM'	'KELLY - MADISONCO	230.00 230KV CKT 1'	200	0.76823	137.1352			'UTICA JCT - VFODNES 230KV CKT 1'
FDNS	09G1010	0 11G	G10_010	TO->FROM'	'KELLY - MADISONCO	230.00 230KV CKT 1'	200	0.77599	143.6168			'FT RANDAL - UTICA JCT 230KV CKT 1'

SOLUTION GROUP	SCENARIK SEASON	SOURCE	DIRECTION	MONITORED ELEMENT	COMMON NAME	RATEB	TDF	TC%	LOAD CONTINGENCY	NAME
FDNS	09G1010	0 11G	G10_010	TO->FROM'	'KELLY - MADISONCO 230.00 230KV CKT 1'	200	0.77351	141.111	'FT RANDAL - SIOUX CITY 230KV CKT 1'	
FDNS	09G1010	0 11G	G10_010	TO->FROM'	'KELLY - MADISONCO 230.00 230KV CKT 1'	200	0.76729	131.9152	'GAVINS POINT - YANKON JCT 115KV CKT 1'	
FDNS	09G1010	0 11G	G10_010	TO->FROM'	'KELLY - MADISONCO 230.00 230KV CKT 1'	200	0.76898	137.1942	'RASMUSN - UTICA JCT 230KV CKT 1'	
FDNS	09G1010	0 11G	G10_010	TO->FROM'	'KELLY - MADISONCO 230.00 230KV CKT 1'	200	0.76898	136.6159	'RASMUSN - SIOUX CITY 230KV CKT 1'	
FDNS	09G1010	0 11G	G10_010	TO->FROM'	'KELLY - MADISONCO 230.00 230KV CKT 1'	200	0.98786	170.6412	'FT RANDAL - MADISONCO 230.00 230KV CKT 1'	
FDNS	09G1010	0 11G	G10_010	TO->FROM'	'KELLY - MADISONCO 230.00 230KV CKT 1'	200	0.76669	103.8	'G06-44N2 230.00 230/34.5KV TRANSFORMER CKT 1'	
FDNS	09G1010	0 11G	G10_010	TO->FROM'	'KELLY - MADISONCO 230.00 230KV CKT 1'	200	0.76669	133.5	'G07-11N9 115.00 115/34.5KV TRANSFORMER CKT 1'	
FDNS	09G1010	0 11G	G10_010	TO->FROM'	'KELLY - MADISONCO 230.00 230KV CKT 1'	200	0.76669	133.4	'BLOOMFIELD 115/34.5KV TRANSFORMER CKT 1'	
FDNS	09G1010	0 11G	G10_010	TO->FROM'	'KELLY - MADISONCO 230.00 230KV CKT 1'	200	0.76672	133.0435	'BLOOMFIELD - GAVINS POINT 115KV CKT 1'	
FDNS	09G1010	0 11G	G10_010	TO->FROM'	'KELLY - MADISONCO 230.00 230KV CKT 1'	200	0.75958	132.8653	'KELLY (KLYT1REG) 230/115/13.2KV TRANSFORMER CKT 1'	
FDNS	09G1010	0 11G	G10_010	TO->FROM'	'KELLY - MADISONCO 230.00 230KV CKT 1'	200	0.76691	133.2723	'ATCHSNT3 345.00 - COOPER 345KV CKT 1'	
FDNS	09G1010	0 11G	G10_010	TO->FROM'	'KELLY - MADISONCO 230.00 230KV CKT 1'	200	0.76669	133.5	'GERALD GENTLEMAN STATION 230/23.0KV TRANSFORMER CK	
FDNS	09G1010	0 11G	G10_010	TO->FROM'	'KELLY - MADISONCO 230.00 230KV CKT 1'	200	0.76684	136.657	'KEYSTONE - SIDNEY 345KV CKT 1'	
FDNS	09G1010	0 11G	G10_010	TO->FROM'	'KELLY - MADISONCO 230.00 230KV CKT 1'	200	0.76887	132.8723	'RAUN - SUB 3451 FT CAL 345KV CKT 1'	
FDNS	09G1010	0 11G	G10_010	TO->FROM'	'KELLY - MADISONCO 230.00 230KV CKT 1'	200	0.76906	133.4325	'FT THOMPSON - GRAND ISLAND 345KV CKT 1'	
FDNS	09G1010	0 11G	G10_010	TO->FROM'	'KELLY - MADISONCO 230.00 230KV CKT 1'	200	0.76669	140	'COUNCIL BLUFFS 345/24.0KV TRANSFORMER CKT 1'	
FDNS	09G1010	0 11G	G10_010	TO->FROM'	'KELLY - MADISONCO 230.00 230KV CKT 1'	200	0.76669	140.4	'COUNCIL BLUFFS 345/26.0KV TRANSFORMER CKT 1'	
FDNS	09G1010	0 11G	G10_010	TO->FROM'	'KELLY - MADISONCO 230.00 230KV CKT 1'	200	0.76669	132.8652	'TRF-KELLY'	
FDNS	09G1010	0 11G	G10_010	TO->FROM'	'KELLY - MADISONCO 230.00 230KV CKT 1'	200	0.77624	143.9777	'DAK02WAPAB2'	
FDNS	09G1010	0 11G	G10_010	TO->FROM'	'KELLY - MADISONCO 230.00 230KV CKT 1'	200	0.76669	104.3861	'GEN560102 1-G06-44N2 0.6900'	
FDNS	09G1010	0 11G	G10_010	TO->FROM'	'KELLY - MADISONCO 230.00 230KV CKT 1'	200	0.76669	137.3727	'GEN640009 1-COOPER NUCLEAR STATION'	
FDNS	09G1010	0 11G	G10_010	TO->FROM'	'KELLY - MADISONCO 230.00 230KV CKT 1'	200	0.76669	137.1207	'GEN640028 1-COLUMCOGENERATION'	
FDNS	09G1010	0 11G	G10_010	TO->FROM'	'KELLY - MADISONCO 230.00 230KV CKT 1'	200	0.76669	136.8901	'GEN645011 1-NEBRASKA CITY 1'	
FDNS	09G1010	0 11G	G10_010	TO->FROM'	'KELLY - MADISONCO 230.00 230KV CKT 1'	200	0.76669	137.1859	'GEN645012 2-NEBRASKA CITY 2'	
FNSL	09G1010	0 11G	G10_010	TO->FROM'	'KELLY - MADISONCO 230.00 230KV CKT 1'	200	0.76669	133.729	'GEN336153 1-WATERFORD UNIT#3'	
FDNS	09G1010	0 11G	G10_010	TO->FROM'	'KELLY - MADISONCO 230.00 230KV CKT 1'	200	0.76669	135.0563	'BASE CASE'	
FDNS	09G1010	0 11G	G10_010	TO->FROM'	'KELLY - MADISONCO 230.00 230KV CKT 1'	200	0.76669	103.8	'G06-44N2 230.00 - MADISONCO 230.00 230KV CKT 1'	
FDNS	09G1010	0 11G	G10_010	TO->FROM'	'FT RANDAL - MADISONCO 230.00 230KV CKT 1'	200	0.98786	174.1864	'KELLY - MADISONCO 230.00 230KV CKT 1'	
FDNS	09G1010	0 11G	G10_010	TO->FROM'	'KELLY - MADISONCO 230.00 230KV CKT 1'	200	0.76669	133.5	'BLOOMFIELD - G07-11N9 115.00 115KV CKT 1'	
FDNS	09G1010	0 11G	G10_010	TO->FROM'	'KELLY - MADISONCO 230.00 230KV CKT 1'	200	0.76748	132.7652	'AINSWORTH - AINSWORTH 115KV CKT 1'	
FDNS	09G1010	0 11G	G10_010	TO->FROM'	'KELLY - MADISONCO 230.00 230KV CKT 1'	200	0.75124	137.8374	'COLUMEAST - NW68TH & HOLDREGE 345KV CKT 1'	
FDNS	09G1010	0 11G	G10_010	TO->FROM'	'KELLY - MADISONCO 230.00 230KV CKT 1'	200	0.75815	132.3943	'COLUMEAST 230/115KV TRANSFORMER CKT 1'	
FDNS	09G1010	0 11G	G10_010	TO->FROM'	'KELLY - MADISONCO 230.00 230KV CKT 1'	200	0.75815	132.3936	'COLUMEAST - KELLY 230KV CKT 1'	
FDNS	09G1010	0 11G	G10_010	TO->FROM'	'KELLY - MADISONCO 230.00 230KV CKT 1'	200	0.74346	138.0364	'COLUMWEST - GRAND ISLAND 230KV CKT 1'	
FDNS	09G1010	0 11G	G10_010	TO->FROM'	'KELLY - MADISONCO 230.00 230KV CKT 1'	200	0.72582	127.2682	'KELLY - SHELL CREEK 230KV CKT 1'	
FDNS	09G1010	0 11G	G10_010	TO->FROM'	'KELLY - MADISONCO 230.00 230KV CKT 1'	200	0.75958	132.8568	'COLUMBUS - KELLY 115KV CKT 1'	
FDNS	09G1010	0 11G	G10_010	TO->FROM'	'KELLY - MADISONCO 230.00 230KV CKT 1'	200	0.76494	133.4363	'COLUMBUS - SCHUYLER 115KV CKT 1'	
FDNS	09G1010	0 11G	G10_010	TO->FROM'	'KELLY - MADISONCO 230.00 230KV CKT 1'	200	0.74913	125.365	'HOSKINS - SHELL CREEK 345KV CKT 1'	
FDNS	09G1010	0 11G	G10_010	TO->FROM'	'KELLY - MADISONCO 230.00 230KV CKT 1'	200	0.76626	133.2986	'NELIGH - PETERSBURG 115KV CKT 1'	
FDNS	09G1010	0 11G	G10_010	TO->FROM'	'KELLY - MADISONCO 230.00 230KV CKT 1'	200	0.72582	127.2209	'SHELL CREEK 345/230KV TRANSFORMER CKT 1'	
FDNS	09G1010	0 11G	G10_010	TO->FROM'	'KELLY - MADISONCO 230.00 230KV CKT 1'	200	0.76691	132.9005	'ATCHSNT3 345.00 - BOONEVILLE 345KV CKT 1'	
FDNS	09G1010	0 11G	G10_010	TO->FROM'	'KELLY - MADISONCO 230.00 230KV CKT 1'	200	0.76796	128.734	'RAUN - SIOUX CITY 345KV CKT 1'	
FDNS	09G1010	0 11G	G10_010	TO->FROM'	'KELLY - MADISONCO 230.00 230KV CKT 1'	200	0.76754	131.1253	'NUNDRWD - WAYSIDE 230KV CKT 1'	
FDNS	09G1010	0 11G	G10_010	TO->FROM'	'KELLY - MADISONCO 230.00 230KV CKT 1'	200	0.76729	131.5573	'STEGALL - WAYSIDE 230KV CKT 1'	
FDNS	09G1010	0 11G	G10_010	TO->FROM'	'KELLY - MADISONCO 230.00 230KV CKT 1'	200	0.76823	137.1352	'UTICA JCT - VFODNES 230KV CKT 1'	
FDNS	09G1010	0 11G	G10_010	TO->FROM'	'KELLY - MADISONCO 230.00 230KV CKT 1'	200	0.77599	143.6168	'FT RANDAL - UTICA JCT 230KV CKT 1'	
FDNS	09G1010	0 11G	G10_010	TO->FROM'	'KELLY - MADISONCO 230.00 230KV CKT 1'	200	0.77351	141.111	'FT RANDAL - SIOUX CITY 230KV CKT 1'	
FDNS	09G1010	0 11G	G10_010	TO->FROM'	'KELLY - MADISONCO 230.00 230KV CKT 1'	200	0.76729	131.9152	'GAVINS POINT - YANKON JCT 115KV CKT 1'	
FDNS	09G1010	0 11G	G10_010	TO->FROM'	'KELLY - MADISONCO 230.00 230KV CKT 1'	200	0.76898	137.1942	'RASMUSN - UTICA JCT 230KV CKT 1'	
FDNS	09G1010	0 11G	G10_010	TO->FROM'	'KELLY - MADISONCO 230.00 230KV CKT 1'	200	0.76898	136.6159	'RASMUSN - SIOUX CITY 230KV CKT 1'	
FDNS	09G1010	0 11G	G10_010	TO->FROM'	'KELLY - MADISONCO 230.00 230KV CKT 1'	200	0.98786	170.6412	'FT RANDAL - MADISONCO 230.00 230KV CKT 1'	
FDNS	09G1010	0 11G	G10_010	TO->FROM'	'KELLY - MADISONCO 230.00 230KV CKT 1'	200	0.76669	103.8	'G06-44N2 230.00 230/34.5KV TRANSFORMER CKT 1'	
FDNS	09G1010	0 11G	G10_010	TO->FROM'	'KELLY - MADISONCO 230.00 230KV CKT 1'	200	0.76669	133.5	'G07-11N9 115.00 115/34.5KV TRANSFORMER CKT 1'	
FDNS	09G1010	0 11G	G10_010	TO->FROM'	'KELLY - MADISONCO 230.00 230KV CKT 1'	200	0.76669	133.4	'BLOOMFIELD 115/34.5KV TRANSFORMER CKT 1'	
FDNS	09G1010	0 11G	G10_010	TO->FROM'	'KELLY - MADISONCO 230.00 230KV CKT 1'	200	0.76672	133.0435	'BLOOMFIELD - GAVINS POINT 115KV CKT 1'	
FDNS	09G1010	0 11G	G10_010	TO->FROM'	'KELLY - MADISONCO 230.00 230KV CKT 1'	200	0.75958	132.8653	'KELLY (KLYT1REG) 230/115/13.2KV TRANSFORMER CKT 1'	
FDNS	09G1010	0 11G	G10_010	TO->FROM'	'KELLY - MADISONCO 230.00 230KV CKT 1'	200	0.76691	133.2723	'ATCHSNT3 345.00 - COOPER 345KV CKT 1'	
FDNS	09G1010	0 11G	G10_010	TO->FROM'	'KELLY - MADISONCO 230.00 230KV CKT 1'	200	0.76669	133.5	'GERALD GENTLEMAN STATION 230/23.0KV TRANSFORMER CK	
FDNS	09G1010	0 11G	G10_010	TO->FROM'	'KELLY - MADISONCO 230.00 230KV CKT 1'	200	0.76684	136.657	'KEYSTONE - SIDNEY 345KV CKT 1'	
FDNS	09G1010	0 11G	G10_010	TO->FROM'	'KELLY - MADISONCO 230.00 230KV CKT 1'	200	0.76887	132.8723	'RAUN - SUB 3451 FT CAL 345KV CKT 1'	
FDNS	09G1010	0 11G	G10_010	TO->FROM'	'KELLY - MADISONCO 230.00 230KV CKT 1'	200	0.76906	133.4325	'FT THOMPSON - GRAND ISLAND 345KV CKT 1'	
FDNS	09G1010	0 11G	G10_010	TO->FROM'	'KELLY - MADISONCO 230.00 230KV CKT 1'	200	0.76669	140	'COUNCIL BLUFFS 345/24.0KV TRANSFORMER CKT 1'	
FDNS	09G1010	0 11G	G10_010	TO->FROM'	'KELLY - MADISONCO 230.00 230KV CKT 1'	200	0.76669	140.4	'COUNCIL BLUFFS 345/26.0KV TRANSFORMER CKT 1'	

SOLUTION GROUP	SCENARI	SEASON	SOURCE	DIRECTION	MONITORED ELEMENT	COMMON NAME	RATEB	TDF	TC%	LOAD	CONTINGENCY	NAME
FDNS	09G1010	0 11G	G10_010	TO->FROM'	'KELLY - MADISONCO	230.00 230KV CKT 1'	200	0.76614	132.9562	'LAKEFIELD 3 - RAUN 345KV CKT 1'		
FDNS	09G1010	0 11G	G10_010	TO->FROM'	'KELLY - MADISONCO	230.00 230KV CKT 1'	200	0.76669	131.5714	'FT RANDAL 230/13.8KV TRANSFORMER CKT 1'		
FDNS	09G1010	0 11G	G10_010	TO->FROM'	'KELLY - MADISONCO	230.00 230KV CKT 1'	200	0.76669	133.3277	'FT RANDAL 230/13.8KV TRANSFORMER CKT 1'		
FDNS	09G1010	0 11G	G10_010	TO->FROM'	'KELLY - MADISONCO	230.00 230KV CKT 1'	200	0.76669	132.718	'FT RANDAL 115/13.8KV TRANSFORMER CKT 1'		
FDNS	09G1010	0 11G	G10_010	TO->FROM'	'KELLY - MADISONCO	230.00 230KV CKT 1'	200	0.75958	132.8652	'TRF-KELLY'		
FDNS	09G1010	0 11G	G10_010	TO->FROM'	'KELLY - MADISONCO	230.00 230KV CKT 1'	200	0.77624	143.9777	'DAK02WAPAB2'		
FDNS	09G1010	0 11G	G10_010	TO->FROM'	'KELLY - MADISONCO	230.00 230KV CKT 1'	200	0.76669	104.3861	'GEN560102 1-G06-44N2 0.6900'		
FDNS	09G1010	0 11G	G10_010	TO->FROM'	'KELLY - MADISONCO	230.00 230KV CKT 1'	200	0.76669	137.3727	'GEN640009 1-COOPER NUCLEAR STATION'		
FDNS	09G1010	0 11G	G10_010	TO->FROM'	'KELLY - MADISONCO	230.00 230KV CKT 1'	200	0.76669	137.1207	'GEN640028 1-COLUMCOGENERATION'		
FDNS	09G1010	0 11G	G10_010	TO->FROM'	'KELLY - MADISONCO	230.00 230KV CKT 1'	200	0.76669	136.8901	'GEN645011 1-NEBRASKA CITY 1'		
FDNS	09G1010	0 11G	G10_010	TO->FROM'	'KELLY - MADISONCO	230.00 230KV CKT 1'	200	0.76669	137.1859	'GEN645012 2-NEBRASKA CITY 2'		
FNSL	09G1010	0 11G	G10_010	TO->FROM'	'KELLY - MADISONCO	230.00 230KV CKT 1'	200	0.76669	133.729	'GEN336153 1-WATERFORD UNIT#3'		
FDNS	09G1010	2 11G	G10_010	TO->FROM'	'KELLY - MADISONCO	230.00 230KV CKT 1'	200	0.43259	98.9	'MADISONCO 3 115.00 - NORFOLK 115KV CKT 1'		
FDNS	09G1010	2 11G	G10_010	TO->FROM'	'KELLY - MADISONCO	230.00 230KV CKT 1'	200	0.43259	98.9	'MADISONCO 3 115.00 - NORFOLK 115KV CKT 1'		
FNSL-Itera 02ALL		0 11G	G10_010		Non Converged		0	0.14304	9999	'SPP-SWPS-02'		
FNSL-Itera 02ALL		0 11G	G10_010		Non Converged		0	0.12665	9999	'SPP-SWPS-02'		
FNSL-Itera 02ALL		0 11G	G10_010		Non Converged		0	0.11061	9999	'DBL-G0847-WO'		
FNSL-Itera 02ALL		0 11G	G10_010		Non Converged		351	0.08264	81.98898	'GRAPEVINE INTERCHANGE - NICHOLS STATION 230KV CKT 1'		
FNSL-Itera 02ALL		0 11G	G10_010		Non Converged		0	0.08059	9999	'ATC_B2_8E2_G'		
FNSL-Itera 02ALL		0 11G	G10_010		Non Converged		0	0.0782	9999	'050 1'		
FNSL-Itera 02ALL		0 11G	G10_010		Non Converged		0	0.07548	9999	'ATC_B2_8E2'		
FNSL-Itera 02ALL		0 11G	G10_010		Non Converged		0	0.07381	9999	'050 2'		
FNSL-Itera 02ALL		0 11G	G10_010		Non Converged		441	0.07022	56.03129	'STLN-DEMARCO6230.00 - SWEETWT6 230.00 230KV CKT 1'		
FNSL-Itera 02ALL		0 11G	G10_010		Non Converged		0	0.05482	9999	'ATC_B2_8E2_G'		
FNSL-Blow 02ALL		0 11G	G10_010		Non Converged		0	0.05289	9999	'050 1'		
FNSL-Itera 02ALL		0 11G	G10_010		Non Converged		0	0.05086	9999	'ATC_B2_8E2'		
FNSL-Itera 02ALL		0 11G	G10_010		Non Converged		0	0.04398	9999	'SPP-SWPS-02'		
FNSL-Itera 02ALL		0 11G	G10_010		Non Converged		351	0.03741	82.03278	'GRAPEVINE INTERCHANGE - NICHOLS STATION 230KV CKT 1'		
FNSL-Itera 02ALL		0 11G	G10_010		Non Converged		0	0.03011	9999	'050 1'		
FNSL-Itera 02ALL		0 11G	G10_010		Non Converged		0	0.02891	9999	'ATC_B2_8E2'		
FNSL-Itera 02ALL		0 11G	G10_010		Non Converged		1052	0.02565	77.23053	'FINNEY SWITCHING STATION - STEVENSCO 345.00 345KV CK'		
FNSL-Itera 02ALL		0 11G	G10_010		Non Converged		1052	0.02294	97.33807	'FINNEY SWITCHING STATION - STEVENSCO 345.00 345KV CK'		
FNSL-Itera 02ALL		0 11G	G10_010		Non Converged		0	0.02212	9999	'ATC_B2_8E2_G'		
FNSL-Itera 02ALL		0 11G	G10_010		Non Converged		0	0.02179	9999	'ATC_B2_8E2'		
FNSL-Itera 00G10_010		0 11WP	G10_010		Non Converged		0	0.08104	9999	'ATC_B2_8E2_G'		
FNSL-Itera 00G10_010		0 11WP	G10_010		Non Converged		1793	0.03931	20.11125	'GEN300015 1-1SGPDEL 18.000'		
FNSL-Itera 00G10_010		0 16SP	G10_010		Non Converged		0	0.03451	9999	'IWA001WAPAB2'		
FNSL-Itera 00G10_010		0 16SP	G10_010		Non Converged		0	0.03451	9999	'ALTW-B111-SW'		
FNSL-Itera 0		0 16SP	G10_010		Non Converged		0	0.03458	9999	'IWA001WAPAB2'		
FNSL-Itera 0		0 16SP	G10_010		Non Converged		0	0.03458	9999	'ALTW-B111-SW'		
FNSL-Itera 0		0 11WP	G10_010		Non Converged		0	0.0813	9999	'ATC_B2_8E2_G'		
FNSL-Itera 0		0 11WP	G10_010		Non Converged		1793	0.03943	19.91273	'GEN300015 1-1SGPDEL 18.000'		
FNSL-Itera 1		0 11G	G10_010		Non Converged		0	0.0788	9999	'050 1'		
FNSL-Itera 1		0 11G	G10_010		Non Converged		0	0.07434	9999	'050 2'		
FNSL-Itera 1		0 11G	G10_010		Non Converged		0	0.07605	9999	'ATC_B2_8E2'		
FNSL-Itera 1		0 11G	G10_010		Non Converged		0	0.08123	9999	'ATC_B2_8E2_G'		
FNSL-Itera 1		2 11G	G10_010		Non Converged		0	0.07882	9999	'050 1'		
FNSL-Itera 1		2 11G	G10_010		Non Converged		0	0.07437	9999	'050 2'		
FNSL-Itera 1		2 11G	G10_010		Non Converged		0	0.07607	9999	'ATC_B2_8E2'		
FNSL-Itera 1		2 11G	G10_010		Non Converged		0	0.08125	9999	'ATC_B2_8E2_G'		
FNSL-Itera 02ALL		0 11G	G10_010		Non Converged		0	0.07801	9999	'050 1'		
FNSL-Itera 02ALL		0 11G	G10_010		Non Converged		0	0.0736	9999	'050 2'		
FNSL-Itera 02ALL		0 11G	G10_010		Non Converged		0	0.07529	9999	'ATC_B2_8E2'		
FNSL-Itera 02ALL		0 11G	G10_010		Non Converged		0	0.08042	9999	'ATC_B2_8E2_G'		
FNSL-Itera 02ALL		2 11G	G10_010		Non Converged		0	0.07807	9999	'050 1'		
FNSL-Itera 02ALL		2 11G	G10_010		Non Converged		0	0.07365	9999	'050 2'		
FNSL-Itera 02ALL		2 11G	G10_010		Non Converged		0	0.07534	9999	'ATC_B2_8E2'		
FNSL-Itera 02ALL		2 11G	G10_010		Non Converged		0	0.07548	9999	'ATC_B2_8E2'		
FNSL-Itera 02ALL		2 11G	G10_010		Non Converged		0	0.08048	9999	'ATC_B2_8E2_G'		
FNSL-Itera 02ALL		3 11G	G10_010		Non Converged		0	0.07819	9999	'050 1'		
FNSL-Itera 02ALL		3 11G	G10_010		Non Converged		0	0.07377	9999	'050 2'		
FNSL-Itera 02ALL		3 11G	G10_010		Non Converged		0	0.07546	9999	'ATC_B2_8E2'		
FNSL-Itera 02ALL		3 11G	G10_010		Non Converged		0	0.08061	9999	'ATC_B2_8E2_G'		
FNSL-Itera 02G08110		0 11G	G10_010		Non Converged		0	0.07821	9999	'050 1'		
FNSL-Itera 02G08110		0 11G	G10_010		Non Converged		0	0.07379	9999	'050 2'		
FNSL-Itera 02G08110		0 11G	G10_010		Non Converged		0	0.07548	9999	'ATC_B2_8E2'		
FNSL-Itera 02G08110		0 11G	G10_010		Non Converged		0	0.08062	9999	'ATC_B2_8E2_G'		
FNSL-Itera 02G08110		2 11G	G10_010		Non Converged		0	0.07824	9999	'050 1'		

SOLUTION GROUP	SCENARI	SEASON	SOURCE	DIRECTION	MONITORED ELEMENT	COMMON NAME	RATEB	TDF	TC%	LOAD	CONTINGENCY	NAME
FNSL-Itera 02G08110		2	11G		G10_010	Non Converged	0	0.07382	9999	'050	2'	
FNSL-Itera 02G08110		2	11G		G10_010	Non Converged	0	0.07551	9999	'ATC_B2_8E2'		
FNSL-Itera 02G08110		2	11G		G10_010	Non Converged	0	0.08065	9999	'ATC_B2_8E2_G'		
FNSL-Itera 02G08110		3	11G		G10_010	Non Converged	0	0.07832	9999	'050	1'	
FNSL-Itera 02G08110		3	11G		G10_010	Non Converged	0	0.07389	9999	'050	2'	
FNSL-Itera 02G08110		3	11G		G10_010	Non Converged	0	0.07559	9999	'ATC_B2_8E2'		
FNSL-Itera 02G08110		3	11G		G10_010	Non Converged	0	0.08073	9999	'ATC_B2_8E2_G'		
FNSL-Itera 02G0847		0	11G		G10_010	Non Converged	0	0.07818	9999	'050	1'	
FNSL-Itera 02G0847		0	11G		G10_010	Non Converged	0	0.07376	9999	'050	2'	
FNSL-Itera 02G0847		0	11G		G10_010	Non Converged	0	0.07545	9999	'ATC_B2_8E2'		
FNSL-Itera 02G0847		0	11G		G10_010	Non Converged	0	0.08059	9999	'ATC_B2_8E2_G'		
FNSL-Itera 02G0847		2	11G		G10_010	Non Converged	0	0.07821	9999	'050	1'	
FNSL-Itera 02G0847		2	11G		G10_010	Non Converged	0	0.07379	9999	'050	2'	
FNSL-Itera 02G0847		2	11G		G10_010	Non Converged	0	0.07548	9999	'ATC_B2_8E2'		
FNSL-Itera 02G0847		2	11G		G10_010	Non Converged	0	0.08062	9999	'ATC_B2_8E2_G'		
FNSL-Itera 02G0847		3	11G		G10_010	Non Converged	0	0.0783	9999	'050	1'	
FNSL-Itera 02G0847		3	11G		G10_010	Non Converged	0	0.07387	9999	'050	2'	
FNSL-Itera 02G0847		3	11G		G10_010	Non Converged	0	0.07557	9999	'ATC_B2_8E2'		
FNSL-Itera 02G0847		3	11G		G10_010	Non Converged	0	0.08071	9999	'ATC_B2_8E2_G'		
FNSL-Itera 02G1007		0	11G		G10_010	Non Converged	0	0.0782	9999	'050	1'	
FNSL-Itera 02G1007		0	11G		G10_010	Non Converged	0	0.07378	9999	'050	2'	
FNSL-Itera 02G1007		0	11G		G10_010	Non Converged	0	0.07547	9999	'ATC_B2_8E2'		
FNSL-Itera 02G1007		0	11G		G10_010	Non Converged	0	0.08061	9999	'ATC_B2_8E2_G'		
FNSL-Itera 02G1007		2	11G		G10_010	Non Converged	0	0.07823	9999	'050	1'	
FNSL-Itera 02G1007		2	11G		G10_010	Non Converged	0	0.07381	9999	'050	2'	
FNSL-Itera 02G1007		2	11G		G10_010	Non Converged	0	0.0755	9999	'ATC_B2_8E2'		
FNSL-Itera 02G1007		2	11G		G10_010	Non Converged	0	0.08064	9999	'ATC_B2_8E2_G'		
FNSL-Itera 02G1007		3	11G		G10_010	Non Converged	0	0.07831	9999	'050	1'	
FNSL-Itera 02G1007		3	11G		G10_010	Non Converged	0	0.07389	9999	'050	2'	
FNSL-Itera 02G1007		3	11G		G10_010	Non Converged	0	0.07558	9999	'ATC_B2_8E2'		
FNSL-Itera 02G1007		3	11G		G10_010	Non Converged	0	0.08072	9999	'ATC_B2_8E2_G'		
FNSL-Itera 02G1014		0	11G		G10_010	Non Converged	0	0.07818	9999	'050	1'	
FNSL-Itera 02G1014		0	11G		G10_010	Non Converged	0	0.07377	9999	'050	2'	
FNSL-Itera 02G1014		0	11G		G10_010	Non Converged	0	0.07546	9999	'ATC_B2_8E2'		
FNSL-Itera 02G1014		0	11G		G10_010	Non Converged	0	0.08059	9999	'ATC_B2_8E2_G'		
FNSL-Itera 02G1014		2	11G		G10_010	Non Converged	0	0.07822	9999	'050	1'	
FNSL-Itera 02G1014		2	11G		G10_010	Non Converged	0	0.0738	9999	'050	2'	
FNSL-Itera 02G1014		2	11G		G10_010	Non Converged	0	0.07549	9999	'ATC_B2_8E2'		
FNSL-Itera 02G1014		2	11G		G10_010	Non Converged	0	0.08063	9999	'ATC_B2_8E2_G'		
FNSL-Itera 02G1014		3	11G		G10_010	Non Converged	0	0.0783	9999	'050	1'	
FNSL-Itera 02G1014		3	11G		G10_010	Non Converged	0	0.07388	9999	'050	2'	
FNSL-Itera 02G1014		3	11G		G10_010	Non Converged	0	0.07557	9999	'ATC_B2_8E2'		
FNSL-Itera 02G1014		3	11G		G10_010	Non Converged	0	0.08072	9999	'ATC_B2_8E2_G'		
FNSL-Itera		2	0	11G	G10_010	Non Converged	0	0.0782	9999	'050	1'	
FNSL-Itera		2	0	11G	G10_010	Non Converged	0	0.07378	9999	'050	2'	
FNSL-Itera		2	0	11G	G10_010	Non Converged	0	0.07547	9999	'ATC_B2_8E2'		
FNSL-Itera		2	0	11G	G10_010	Non Converged	0	0.08061	9999	'ATC_B2_8E2_G'		
FNSL-Itera		2	2	11G	G10_010	Non Converged	0	0.07823	9999	'050	1'	
FNSL-Itera		2	2	11G	G10_010	Non Converged	0	0.07381	9999	'050	2'	
FNSL-Itera		2	2	11G	G10_010	Non Converged	0	0.0755	9999	'ATC_B2_8E2'		
FNSL-Itera		2	2	11G	G10_010	Non Converged	0	0.08064	9999	'ATC_B2_8E2_G'		
FNSL-Itera		2	3	11G	G10_010	Non Converged	0	0.07831	9999	'050	1'	
FNSL-Itera		2	3	11G	G10_010	Non Converged	0	0.07389	9999	'050	2'	
FNSL-Itera		2	3	11G	G10_010	Non Converged	0	0.07558	9999	'ATC_B2_8E2'		
FNSL-Itera		2	3	11G	G10_010	Non Converged	0	0.08073	9999	'ATC_B2_8E2_G'		
FNSL-Blow 03ALL		0	11G		G10_010	Non Converged	0	0.03554	9999	'DBL-SPRVL-CO'		
FNSL-Blow 03ALL		0	11G		G10_010	Non Converged	0	0.03554	9999	'DBL-COM-MEDL'		
FNSL-Itera 03ALL		0	11G		G10_010	Non Converged	0	0.0772	9999	'050	1'	
FNSL-Itera 03ALL		0	11G		G10_010	Non Converged	0	0.07285	9999	'050	2'	
FNSL-Itera 03ALL		0	11G		G10_010	Non Converged	0	0.07451	9999	'ATC_B2_8E2'		
FNSL-Itera 03ALL		0	11G		G10_010	Non Converged	0	0.07958	9999	'ATC_B2_8E2_G'		
FNSL-Itera		3	0	11G	G10_010	Non Converged	0	0.07769	9999	'050	1'	
FNSL-Itera		3	0	11G	G10_010	Non Converged	0	0.07331	9999	'050	2'	
FNSL-Itera		3	0	11G	G10_010	Non Converged	0	0.07498	9999	'ATC_B2_8E2'		
FNSL-Itera		3	0	11G	G10_010	Non Converged	0	0.08008	9999	'ATC_B2_8E2_G'		
FNSL-Itera		3	2	11G	G10_010	Non Converged	0	0.0777	9999	'050	1'	
FNSL-Itera		3	2	11G	G10_010	Non Converged	0	0.07331	9999	'050	2'	

SOLUTION GROUP	SCENARIK	SEASON	SOURCE	DIRECTION	MONITORED ELEMENT	COMMON NAME	RATEB	TDF	TC%	LOAD	CONTINGENCY NAME
FNSL-Itera	3	2	11G		G10_010	Non Converged	0	0.07498	9999	'ATC_B2_8E2'	
FNSL-Itera	3	2	11G		G10_010	Non Converged	0	0.08008	9999	'ATC_B2_8E2_G'	
FNSL-Itera	5	0	11G		G10_010	Non Converged	0	0.07869	9999	'050 1'	
FNSL-Itera	5	0	11G		G10_010	Non Converged	0	0.07424	9999	'050 2'	
FNSL-Itera	5	0	11G		G10_010	Non Converged	0	0.07594	9999	'ATC_B2_8E2'	
FNSL-Itera	5	0	11G		G10_010	Non Converged	0	0.08111	9999	'ATC_B2_8E2_G'	
FNSL-Itera	6	0	11G		G10_010	Non Converged	0	0.07884	9999	'050 1'	
FNSL-Itera	6	0	11G		G10_010	Non Converged	0	0.07439	9999	'050 2'	
FNSL-Itera	6	0	11G		G10_010	Non Converged	0	0.07609	9999	'ATC_B2_8E2'	
FNSL-Itera	6	0	11G		G10_010	Non Converged	0	0.08128	9999	'ATC_B2_8E2_G'	
FNSL-Itera	7	0	11G		G10_010	Non Converged	0	0.07907	9999	'050 1'	
FNSL-Itera	7	0	11G		G10_010	Non Converged	0	0.0746	9999	'050 2'	
FNSL-Itera	7	0	11G		G10_010	Non Converged	0	0.07631	9999	'ATC_B2_8E2'	
FNSL-Itera	7	0	11G		G10_010	Non Converged	0	0.08151	9999	'ATC_B2_8E2_G'	
FNSL-Itera	7	2	11G		G10_010	Non Converged	0	0.07908	9999	'050 1'	
FNSL-Itera	7	2	11G		G10_010	Non Converged	0	0.07461	9999	'050 2'	
FNSL-Itera	7	2	11G		G10_010	Non Converged	0	0.07632	9999	'ATC_B2_8E2'	
FNSL-Itera	7	2	11G		G10_010	Non Converged	0	0.08152	9999	'ATC_B2_8E2_G'	
FNSL-Itera	8	0	11G		G10_010	Non Converged	0	0.0789	9999	'050 1'	
FNSL-Itera	8	0	11G		G10_010	Non Converged	0	0.07445	9999	'050 2'	
FNSL-Itera	8	0	11G		G10_010	Non Converged	0	0.07615	9999	'ATC_B2_8E2'	
FNSL-Itera	8	0	11G		G10_010	Non Converged	0	0.08133	9999	'ATC_B2_8E2_G'	
FNSL-Itera 09G1010		0	11G		G10_010	Non Converged	0	0.07744	9999	'050 1'	
FNSL-Itera 09G1010		0	11G		G10_010	Non Converged	0	0.07306	9999	'050 2'	
FNSL-Itera 09G1010		0	11G		G10_010	Non Converged	0	0.07473	9999	'ATC_B2_8E2'	
FNSL-Itera 09G1010		2	11G		G10_010	Non Converged	0	0.07844	9999	'050 1'	
FNSL-Itera 09G1010		2	11G		G10_010	Non Converged	0	0.07394	9999	'050 2'	
FNSL-Itera 09G1010		2	11G		G10_010	Non Converged	0	0.07571	9999	'ATC_B2_8E2'	
FNSL-Itera 9		0	11G		G10_010	Non Converged	0	0.07749	9999	'050 1'	
FNSL-Itera 9		0	11G		G10_010	Non Converged	0	0.07312	9999	'050 2'	
FNSL-Itera 9		0	11G		G10_010	Non Converged	0	0.07479	9999	'ATC_B2_8E2'	
FNSL-Itera 9		0	11G		G10_010	Non Converged	0	0.07988	9999	'ATC_B2_8E2_G'	
FNSL-Itera 9		2	11G		G10_010	Non Converged	0	0.0785	9999	'050 1'	
FNSL-Itera 9		2	11G		G10_010	Non Converged	0	0.07399	9999	'050 2'	
FNSL-Itera 9		2	11G		G10_010	Non Converged	0	0.07577	9999	'ATC_B2_8E2'	
FNSL-Itera 9		2	11G		G10_010	Non Converged	0	0.08101	9999	'ATC_B2_8E2_G'	
FNSL-Itera 11		0	11G		G10_010	Non Converged	0	0.0784	9999	'050 1'	
FNSL-Itera 11		0	11G		G10_010	Non Converged	0	0.07398	9999	'050 2'	
FNSL-Itera 11		0	11G		G10_010	Non Converged	0	0.07567	9999	'ATC_B2_8E2'	
FNSL-Itera 11		0	11G		G10_010	Non Converged	0	0.08081	9999	'ATC_B2_8E2_G'	
FNSL-Itera 11		2	11G		G10_010	Non Converged	0	0.0784	9999	'050 1'	
FNSL-Itera 11		2	11G		G10_010	Non Converged	0	0.07398	9999	'050 2'	
FNSL-Itera 11		2	11G		G10_010	Non Converged	0	0.07567	9999	'ATC_B2_8E2'	
FNSL-Itera 11		2	11G		G10_010	Non Converged	0	0.08081	9999	'ATC_B2_8E2_G'	
FNSL-Itera 13		0	11G		G10_010	Non Converged	0	0.07816	9999	'050 1'	
FNSL-Itera 13		0	11G		G10_010	Non Converged	0	0.07376	9999	'050 2'	
FNSL-Itera 13		0	11G		G10_010	Non Converged	0	0.07543	9999	'ATC_B2_8E2'	
FNSL-Itera 13		0	11G		G10_010	Non Converged	0	0.08055	9999	'ATC_B2_8E2_G'	
FNSL-Itera 14		0	11G		G10_010	Non Converged	0	0.07896	9999	'050 1'	
FNSL-Itera 14		0	11G		G10_010	Non Converged	0	0.0745	9999	'050 2'	
FNSL-Itera 14		0	11G		G10_010	Non Converged	0	0.0762	9999	'ATC_B2_8E2'	
FNSL-Itera 14		0	11G		G10_010	Non Converged	0	0.08139	9999	'ATC_B2_8E2_G'	
FNSL-Itera 15		0	11G		G10_010	Non Converged	0	0.07881	9999	'050 1'	
FNSL-Itera 15		0	11G		G10_010	Non Converged	0	0.07436	9999	'050 2'	
FNSL-Itera 15		0	11G		G10_010	Non Converged	0	0.07606	9999	'ATC_B2_8E2'	
FNSL-Itera 15		0	11G		G10_010	Non Converged	0	0.08124	9999	'ATC_B2_8E2_G'	
FDNS 1		0	11G		G10_011	'TO->FROM'	1195	0.48872	104.2029	'DBL-MEDLO-WI'	
FDNS 1		0	11G		G10_011	'TO->FROM'	1195	0.48872	104.2029	'DBL-MEDLO-WI'	
FDNS 1		2	11G		G10_011	'TO->FROM'	1195	0.51046	95.8	'DBL-WOOD-MED'	
FDNS 1		2	11G		G10_011	'TO->FROM'	1195	0.51046	95.8	'DBL-WOOD-MED'	
FDNS 02ALL		0	11G		G10_011	'TO->FROM'	1195	0.49492	103.8577	'DBL-MEDLO-WI'	
FDNS 02ALL		0	11G		G10_011	'TO->FROM'	1195	0.49492	103.8577	'DBL-MEDLO-WI'	
FDNS 01G1011		0	11G		G10_011	'TO->FROM'	1195	0.48864	104.4745	'DBL-MEDLO-WI'	
FDNS 01G1011		0	11G		G10_011	'TO->FROM'	1195	0.48864	104.4745	'DBL-MEDLO-WI'	
FDNS 01G1011		2	11G		G10_011	'TO->FROM'	1195	0.51036	96.1	'DBL-WOOD-MED'	
FDNS 01G1011		2	11G		G10_011	'TO->FROM'	1195	0.51036	96.1	'DBL-WOOD-MED'	
FDNS 02ALL		0	11G		G10_011	'TO->FROM'	1195	0.4555	95.8	'LAWTON EASTSIDE - OKLAUNION 345KV CKT 1'	

SOLUTION GROUP	SCENARIK	SEASON	SOURCE	DIRECTION	MONITORED ELEMENT	COMMON NAME	RATEB	TDF	TC%	LOAD	CONTINGENCY	NAME
FDNS	02ALL	0	11G	G10_011	'TO->FROM'	'NORTHWEST - TATONGA7	345.00	345KV	1195	0.48538	109.8945	'DBL-MEDLO-WI'
FDNS	02ALL	0	11G	G10_011	'TO->FROM'	'NORTHWEST - TATONGA7	345.00	345KV	1195	0.53368	108.4191	'DBL-WOOD-MED'
FDNS	02ALL	2	11G	G10_011	'TO->FROM'	'NORTHWEST - TATONGA7	345.00	345KV	1195	0.45357	98	'LAWTON EASTSIDE - OKLAUNION 345KV
FDNS	02ALL	2	11G	G10_011	'TO->FROM'	'NORTHWEST - TATONGA7	345.00	345KV	1195	0.48417	112.085	'DBL-MEDLO-WI'
FDNS	02ALL	2	11G	G10_011	'TO->FROM'	'NORTHWEST - TATONGA7	345.00	345KV	1195	0.52922	112.4579	'DBL-WOOD-MED'
FDNS	02G08110	0	11G	G10_011	'TO->FROM'	'NORTHWEST - TATONGA7	345.00	345KV	1195	0.49199	95.7	'DBL-MEDLO-WI'
FDNS	02G08110	0	11G	G10_011	'TO->FROM'	'NORTHWEST - TATONGA7	345.00	345KV	1195	0.54078	95.1	'DBL-WOOD-MED'
FDNS	02G08110	2	11G	G10_011	'TO->FROM'	'NORTHWEST - TATONGA7	345.00	345KV	1195	0.49085	97.3	'DBL-MEDLO-WI'
FDNS	02G08110	2	11G	G10_011	'TO->FROM'	'NORTHWEST - TATONGA7	345.00	345KV	1195	0.53651	98	'DBL-WOOD-MED'
FDNS	02G0847	0	11G	G10_011	'TO->FROM'	'NORTHWEST - TATONGA7	345.00	345KV	1195	0.49137	97.4	'DBL-MEDLO-WI'
FDNS	02G0847	0	11G	G10_011	'TO->FROM'	'NORTHWEST - TATONGA7	345.00	345KV	1195	0.54001	97.1	'DBL-WOOD-MED'
FDNS	02G0847	2	11G	G10_011	'TO->FROM'	'NORTHWEST - TATONGA7	345.00	345KV	1195	0.49023	99	'DBL-MEDLO-WI'
FDNS	02G0847	2	11G	G10_011	'TO->FROM'	'NORTHWEST - TATONGA7	345.00	345KV	1195	0.53575	100	'DBL-WOOD-MED'
FDNS	02G1007	2	11G	G10_011	'TO->FROM'	'NORTHWEST - TATONGA7	345.00	345KV	1195	0.49122	96.4	'DBL-MEDLO-WI'
FDNS	02G1007	2	11G	G10_011	'TO->FROM'	'NORTHWEST - TATONGA7	345.00	345KV	1195	0.53694	96.9	'DBL-WOOD-MED'
FDNS	02G1014	0	11G	G10_011	'TO->FROM'	'NORTHWEST - TATONGA7	345.00	345KV	1195	0.49188	96	'DBL-MEDLO-WI'
FDNS	02G1014	0	11G	G10_011	'TO->FROM'	'NORTHWEST - TATONGA7	345.00	345KV	1195	0.54066	95.4	'DBL-WOOD-MED'
FDNS	02G1014	2	11G	G10_011	'TO->FROM'	'NORTHWEST - TATONGA7	345.00	345KV	1195	0.49073	97.6	'DBL-MEDLO-WI'
FDNS	02G1014	2	11G	G10_011	'TO->FROM'	'NORTHWEST - TATONGA7	345.00	345KV	1195	0.53639	98.3	'DBL-WOOD-MED'
FDNS	2	2	11G	G10_011	'TO->FROM'	'NORTHWEST - TATONGA7	345.00	345KV	1195	0.49133	96.1	'DBL-MEDLO-WI'
FDNS	2	2	11G	G10_011	'TO->FROM'	'NORTHWEST - TATONGA7	345.00	345KV	1195	0.53707	96.5	'DBL-WOOD-MED'
FNSL-Itera 02ALL		0	11G	G10_011		Non Converged			1052	0.14352	77.23053	'FINNEY SWITCHING STATION - STEVENSCO 345.00 345KV
FNSL-Itera 02ALL		0	11G	G10_011		Non Converged			0	0.12667	9999	'SPP-SWPS-02'
FNSL-Itera 02ALL		0	11G	G10_011		Non Converged			1052	0.11273	97.33807	'FINNEY SWITCHING STATION - STEVENSCO 345.00 345KV
FNSL-Itera 02ALL		0	11G	G10_011		Non Converged			351	0.08265	82.03278	'GRAPEVINE INTERCHANGE - NICHOLS STATION 230KV
FNSL-Itera 02ALL		0	11G	G10_011		Non Converged			0	0.08059	9999	'ATC_B2_8E2_G'
FNSL-Itera 02ALL		0	11G	G10_011		Non Converged			0	0.0782	9999	'050 1'
FNSL-Itera 02ALL		0	11G	G10_011		Non Converged			0	0.07548	9999	'ATC_B2_8E2'
FNSL-Itera 02ALL		0	11G	G10_011		Non Converged			0	0.07381	9999	'050 2'
FNSL-Itera 02ALL		0	11G	G10_011		Non Converged			441	0.07139	57.58744	'STATELINE INTERCHANGE - STLN-DEMARC6230.00 230KV
FNSL-Itera 02ALL		0	11G	G10_011		Non Converged			0	0.05482	9999	'ATC_B2_8E2_G'
FNSL-Blow 02ALL		0	11G	G10_011		Non Converged			0	0.05289	9999	'050 1'
FNSL-Itera 02ALL		0	11G	G10_011		Non Converged			0	0.0509	9999	'ATC_B2_8E2'
FNSL-Itera 02ALL		0	11G	G10_011		Non Converged			0	0.04398	9999	'SPP-SWPS-02'
FNSL-Itera 02ALL		0	11G	G10_011		Non Converged			351	0.03741	82.03278	'GRAPEVINE INTERCHANGE - NICHOLS STATION 230KV
FNSL-Itera 02ALL		0	11G	G10_011		Non Converged			0	0.03011	9999	'050 1'
FNSL-Itera 02ALL		0	11G	G10_011		Non Converged			0	0.02891	9999	'ATC_B2_8E2'
FNSL-Itera 02ALL		0	11G	G10_011		Non Converged			0	0.02567	9999	'TRF-STEGALL'
FNSL-Itera 02ALL		0	11G	G10_011		Non Converged			0	0.02307	9999	'ATC_B2_8E2_G'
FNSL-Itera 02ALL		0	11G	G10_011		Non Converged			441	0.02212	56.34883	'STATELINE INTERCHANGE - STLN-DEMARC6230.00 230KV
FNSL-Itera 02ALL		0	11G	G10_011		Non Converged			0	0.0218	9999	'ATC_B2_8E2'
FNSL-Itera 02ALL		2	11G	G10_011		Non Converged			1052	0.03153	82.65054	'FINNEY SWITCHING STATION - STEVENSCO 345.00 345KV
FNSL-Itera 02G1007		0	11G	G10_011		Non Converged			1052	0.03101	77.23053	'FINNEY SWITCHING STATION - STEVENSCO 345.00 345KV
FNSL-Itera 2		0	11G	G10_011		Non Converged			1052	0.03112	76.82405	'FINNEY SWITCHING STATION - STEVENSCO 345.00 345KV
FNSL-Blow 03ALL		0	11G	G10_011		Non Converged			0	0.11072	9999	'DBL-MEDLO-WI'
FNSL-Itera 02ALL		0	11G	G10_013		Non Converged			0	0.14291	9999	'SPP-SWPS-02'
FNSL-Itera 02ALL		0	11G	G10_013		Non Converged			1052	0.12459	82.65054	'FINNEY SWITCHING STATION - STEVENSCO 345.00 345KV
FNSL-Itera 02ALL		0	11G	G10_013		Non Converged			0	0.10657	9999	'SPP-SWPS-T53'
FNSL-Itera 02ALL		0	11G	G10_013		Non Converged			0	0.08073	9999	'ATC_B2_8E2_G'
FNSL-Itera 02ALL		0	11G	G10_013		Non Converged			0	0.08059	9999	'ATC_B2_8E2_G'
FNSL-Itera 02ALL		0	11G	G10_013		Non Converged			0	0.07819	9999	'050 1'
FNSL-Itera 02ALL		0	11G	G10_013		Non Converged			0	0.07548	9999	'ATC_B2_8E2'
FNSL-Itera 02ALL		0	11G	G10_013		Non Converged			0	0.0738	9999	'050 2'
FNSL-Itera 02ALL		0	11G	G10_013		Non Converged			441	0.07022	56.34883	'STATELINE INTERCHANGE - STLN-DEMARC6230.00 230KV
FNSL-Itera 02ALL		0	11G	G10_013		Non Converged			0	0.05482	9999	'ATC_B2_8E2_G'
FNSL-Blow 02ALL		0	11G	G10_013		Non Converged			0	0.05278	9999	'050 1'
FNSL-Itera 02ALL		0	11G	G10_013		Non Converged			0	0.05071	9999	'DBL-HIT-G084'
FNSL-Itera 02ALL		0	11G	G10_013		Non Converged			0	0.04273	9999	'DBL-G0847-WO'
FNSL-Itera 02ALL		0	11G	G10_013		Non Converged			351	0.0374	81.98898	'GRAPEVINE INTERCHANGE - NICHOLS STATION 230KV
FNSL-Itera 02ALL		0	11G	G10_013		Non Converged			0	0.0301	9999	'050 1'
FNSL-Itera 02ALL		0	11G	G10_013		Non Converged			0	0.0289	9999	'ATC_B2_8E2'
FNSL-Itera 02ALL		0	11G	G10_013		Non Converged			0	0.02555	9999	'SPP-SWPS-03'
FNSL-Itera 02ALL		0	11G	G10_013		Non Converged			1052	0.02294	97.33807	'FINNEY SWITCHING STATION - STEVENSCO 345.00 345KV
FNSL-Itera 02ALL		0	11G	G10_013		Non Converged			0	0.02211	9999	'ATC_B2_8E2_G'
FNSL-Itera 02ALL		0	11G	G10_013		Non Converged			0	0.02175	9999	'NEB01WAPAB3'
FDNS	1	0	11G	G10_014	'TO->FROM'	'NORTHWEST - TATONGA7	345.00	345KV	1195	0.22547	104.2029	'DBL-MEDLO-WI'
FDNS	1	0	11G	G10_014	'TO->FROM'	'NORTHWEST - TATONGA7	345.00	345KV	1195	0.22547	104.2029	'DBL-MEDLO-WI'

SOLUTION GROUP	SCENARIK	SEASON	SOURCE	DIRECTION	MONITORED ELEMENT	COMMON NAME	RATEB	TDF	TC%	LOAD	CONTINGENCY	NAME
FDNS	1	2 11G	G10_014	'TO->FROM'	'NORTHWEST - TATONGA7	345.00 345KV CKT 1'	1195	0.22495	95.8	'DBL-WOOD-MED'		
FDNS	1	2 11G	G10_014	'TO->FROM'	'NORTHWEST - TATONGA7	345.00 345KV CKT 1'	1195	0.22495	95.8	'DBL-WOOD-MED'		
FNSL-Itera	2	0 11G	G10_014			Non Converged	0	0.60162	9999	'DBL-G0847-WO'		
FNSL-Itera	2	0 11G	G10_014			Non Converged	0	0.60162	9999	'DBL-G0847-WO'		
FNSL-Blow 02ALL		0 11G	G10_014			Non Converged	0	0.26785	86.2944	'FINNEY SWITCHING STATION - STEVENSCO	345.00 345KV CKT	
FNSL-Blow 02ALL		0 11G	G10_014			Non Converged	0	0.2369	9999	'DBL-HIT-G084'		
FNSL-Blow 02ALL		0 11G	G10_014			Non Converged	0	0.2369	9999	'DBL-G0847-WO'		
FDNS 02ALL		0 11G	G10_014	'TO->FROM'	'NORTHWEST - TATONGA7	345.00 345KV CKT 1'	1195	0.19683	103.8577	'DBL-MEDLO-WI'		
FNSL-Blow 02ALL		0 11G	G10_014			Non Converged	0	0.26785	86.2944	'FINNEY SWITCHING STATION - STEVENSCO	345.00 345KV CKT	
FNSL-Blow 02ALL		0 11G	G10_014			Non Converged	0	0.2369	9999	'DBL-HIT-G084'		
FNSL-Blow 02ALL		0 11G	G10_014			Non Converged	0	0.2369	9999	'DBL-G0847-WO'		
FDNS 02ALL		0 11G	G10_014	'TO->FROM'	'NORTHWEST - TATONGA7	345.00 345KV CKT 1'	1195	0.19683	103.8577	'DBL-MEDLO-WI'		
FNSL-Blow 02G1014		0 11G	G10_014			Non Converged	0	0.60001	9999	'DBL-G0847-WO'		
FNSL-Blow 02G1014		0 11G	G10_014			Non Converged	0	0.60001	9999	'DBL-G0847-WO'		
FDNS 02ALL		0 11G	G10_014	'TO->FROM'	'FINNEY SWITCHING STATION - STEVENSCO	345.00	1052	0.22103	97.3	'BASE CASE'		
FDNS 02ALL		0 11G	G10_014	'TO->FROM'	'FINNEY SWITCHING STATION - STEVENSCO	345.00	1052	0.22905	100.4567	'LAWTON EASTSIDE - OKLAUNION 345KV CKT 1'		
FDNS 02ALL		0 11G	G10_014	'TO->FROM'	'FINNEY SWITCHING STATION - STEVENSCO	345.00	1052	0.22905	95	'G05-15T 345.00 - OKLAUNION 345KV CKT 1'		
FDNS 02ALL		0 11G	G10_014	'TO->FROM'	'NORTHWEST - TATONGA7	345.00 345KV CKT 1'	1195	0.20943	108.4191	'DBL-WOOD-MED'		
FDNS 02ALL		0 11G	G10_014	'TO->FROM'	'FINNEY SWITCHING STATION - STEVENSCO	345.00	1052	0.28162	115.9808	'DBL-WOOD-MED'		
FDNS 02ALL		0 11G	G10_014	'TO->FROM'	'FINNEY SWITCHING STATION - STEVENSCO	345.00	1052	0.22783	95.4	'SPP-SWPS-03'		
FDNS 02ALL		0 11G	G10_014	'TO->FROM'	'FINNEY SWITCHING STATION - STEVENSCO	345.00	1052	0.22103	98.1	'GEN531447 1-HOLCOMB GENERATOR'		
FNSL-Blow 02ALL		0 11G	G10_014			Non Converged	0	0.22103	97.33807	'FINNEY SWITCHING STATION - STEVENSCO	345.00 345KV CKT	
FNSL-Blow 02ALL		0 11G	G10_014			Non Converged	0	0.44949	9999	'DBL-HIT-G084'		
FNSL-Blow 02ALL		0 11G	G10_014			Non Converged	0	0.42793	9999	'DBL-G0847-WO'		
FDNS 02ALL		0 11G	G10_014	'TO->FROM'	'FINNEY SWITCHING STATION - STEVENSCO	345.00	1052	0.22715	96.7	'ELK CITY 230KV - SWEETWT6 230.00 230KV CKT 1'		
FDNS 02ALL		0 11G	G10_014	'TO->FROM'	'FINNEY SWITCHING STATION - STEVENSCO	345.00	1052	0.23624	98.6	'NORTHWEST - TATONGA7 345.00 345KV CKT 1'		
FDNS 02ALL		0 11G	G10_014	'TO->FROM'	'FINNEY SWITCHING STATION - STEVENSCO	345.00	1052	0.23703	96.7	'TATONGA7 345.00 - WWRDEHV7 345.00 345KV CKT 1'		
FDNS 02ALL		0 11G	G10_014	'TO->FROM'	'FINNEY SWITCHING STATION - STEVENSCO	345.00	1052	0.25271	105.5006	'2008-047 TAP345.00 - WWRDEHV7 345.00 345KV CKT 1'		
FDNS 02ALL		0 11G	G10_014	'TO->FROM'	'FINNEY SWITCHING STATION - STEVENSCO	345.00	1052	0.25271	105.5006	'2008-047 TAP345.00 - WWRDEHV7 345.00 345KV CKT 2'		
FDNS 02ALL		0 11G	G10_014	'TO->FROM'	'FINNEY SWITCHING STATION - STEVENSCO	345.00	1052	0.23671	95.7	'MED-LDG5 345.00 - WWRDEHV7 345.00 345KV CKT 1'		
FDNS 02ALL		0 11G	G10_014	'TO->FROM'	'FINNEY SWITCHING STATION - STEVENSCO	345.00	1052	0.23671	95.7	'MED-LDG5 345.00 - WWRDEHV7 345.00 345KV CKT 2'		
FDNS 02ALL		0 11G	G10_014	'TO->FROM'	'FINNEY SWITCHING STATION - STEVENSCO	345.00	1052	0.25431	99	'2008-047 TAP345.00 - Hitchland Interchange 345KV CKT 1'		
FDNS 02ALL		0 11G	G10_014	'TO->FROM'	'FINNEY SWITCHING STATION - STEVENSCO	345.00	1052	0.25431	99	'2008-047 TAP345.00 - Hitchland Interchange 345KV CKT 2'		
FDNS 02ALL		0 11G	G10_014	'FROM->TO'	'FINNEY SWITCHING STATION - HOLCOMB 345KV CK'		1052	0.21788	95.1	'FINNEY SWITCHING STATION - HOLCOMB 345KV CKT 1'		
FDNS 02ALL		0 11G	G10_014	'FROM->TO'	'FINNEY SWITCHING STATION - HOLCOMB 345KV CK'		1052	0.21788	95.1	'FINNEY SWITCHING STATION - HOLCOMB 345KV CKT 2'		
FDNS 02ALL		0 11G	G10_014	'TO->FROM'	'FINNEY SWITCHING STATION - STEVENSCO	345.00	1052	0.22715	96.7	'ELK CITY 230KV (ELKCTY-6) 230/138/13.8KV TRANSFORMER CK'		
FNSL-Itera 02ALL		2 11G	G10_014			Non Converged	0	0.30841	9999	'DBL-G0847-WO'		
FDNS 02ALL		2 11G	G10_014	'TO->FROM'	'NORTHWEST - TATONGA7	345.00 345KV CKT 1'	1195	0.19247	112.085	'DBL-MEDLO-WI'		
FDNS 02ALL		2 11G	G10_014	'TO->FROM'	'FINNEY SWITCHING STATION - STEVENSCO	345.00	1052	0.28018	99.5	'DBL-HIT-G084'		
FDNS 02ALL		2 11G	G10_014	'TO->FROM'	'NORTHWEST - TATONGA7	345.00 345KV CKT 1'	1195	0.22052	112.4579	'DBL-WOOD-MED'		
FDNS 02ALL		2 11G	G10_014	'TO->FROM'	'FINNEY SWITCHING STATION - STEVENSCO	345.00	1052	0.25918	107.259	'DBL-WOOD-MED'		
FDNS 02ALL		3 11G	G10_014	'TO->FROM'	'FINNEY SWITCHING STATION - STEVENSCO	345.00	1052	0.24638	113.9175	'DBL-G0847-WO'		
FNSL-Blow 02G08110		0 11G	G10_014			Non Converged	0	0.44005	9999	'DBL-G0847-WO'		
FDNS 02G08110		0 11G	G10_014	'TO->FROM'	'NORTHWEST - TATONGA7	345.00 345KV CKT 1'	1195	0.1939	95.7	'DBL-MEDLO-WI'		
FDNS 02G08110		0 11G	G10_014	'TO->FROM'	'FINNEY SWITCHING STATION - STEVENSCO	345.00	1052	0.47937	132.1299	'DBL-HIT-G084'		
FDNS 02G08110		0 11G	G10_014	'TO->FROM'	'NORTHWEST - TATONGA7	345.00 345KV CKT 1'	1195	0.21652	95.1	'DBL-WOOD-MED'		
FDNS 02G08110		0 11G	G10_014	'TO->FROM'	'FINNEY SWITCHING STATION - STEVENSCO	345.00	1052	0.29125	96.4	'DBL-WOOD-MED'		
FDNS 02G08110		2 11G	G10_014	'TO->FROM'	'NORTHWEST - TATONGA7	345.00 345KV CKT 1'	1195	0.19915	97.3	'DBL-MEDLO-WI'		
FDNS 02G08110		2 11G	G10_014	'TO->FROM'	'FINNEY SWITCHING STATION - STEVENSCO	345.00	1052	0.28388	97	'DBL-G0847-WO'		
FDNS 02G08110		2 11G	G10_014	'TO->FROM'	'NORTHWEST - TATONGA7	345.00 345KV CKT 1'	1195	0.22781	98	'DBL-WOOD-MED'		
FNSL-Itera 02G0847		0 11G	G10_014			Non Converged	0	0.43881	9999	'DBL-G0847-WO'		
FDNS 02G0847		0 11G	G10_014	'TO->FROM'	'NORTHWEST - TATONGA7	345.00 345KV CKT 1'	1195	0.19327	97.4	'DBL-MEDLO-WI'		
FDNS 02G0847		0 11G	G10_014	'TO->FROM'	'FINNEY SWITCHING STATION - STEVENSCO	345.00	1052	0.4806	128.0221	'DBL-HIT-G084'		
FDNS 02G0847		0 11G	G10_014	'TO->FROM'	'NORTHWEST - TATONGA7	345.00 345KV CKT 1'	1195	0.21576	97.1	'DBL-WOOD-MED'		
FDNS 02G0847		0 11G	G10_014	'TO->FROM'	'FINNEY SWITCHING STATION - STEVENSCO	345.00	1052	0.29086	98	'DBL-WOOD-MED'		
FDNS 02G0847		2 11G	G10_014	'TO->FROM'	'NORTHWEST - TATONGA7	345.00 345KV CKT 1'	1195	0.19853	99	'DBL-MEDLO-WI'		
FDNS 02G0847		2 11G	G10_014	'TO->FROM'	'NORTHWEST - TATONGA7	345.00 345KV CKT 1'	1195	0.22705	100	'DBL-WOOD-MED'		
FNSL 02G0847		2 11G	G10_014	'TO->FROM'	'FINNEY SWITCHING STATION - STEVENSCO	345.00	1052	0.28324	99.7	'DBL-G0847-WO'		
FDNS 02G1007		0 11G	G10_014	'TO->FROM'	'FINNEY SWITCHING STATION - STEVENSCO	345.00	1052	0.48028	128.8406	'DBL-HIT-G084'		
FNSL-Itera 02G1007		0 11G	G10_014			Non Converged	0	0.2291	77.23053	'FINNEY SWITCHING STATION - STEVENSCO	345.00 345KV CKT	
FNSL-Itera 02G1007		0 11G	G10_014			Non Converged	0	0.44133	9999	'DBL-G0847-WO'		
FDNS 02G1007		2 11G	G10_014	'TO->FROM'	'NORTHWEST - TATONGA7	345.00 345KV CKT 1'	1195	0.19953	96.4	'DBL-MEDLO-WI'		
FDNS 02G1007		2 11G	G10_014	'TO->FROM'	'NORTHWEST - TATONGA7	345.00 345KV CKT 1'	1195	0.22824	96.9	'DBL-WOOD-MED'		
FNSL-Itera 02G1007		2 11G	G10_014			Non Converged	0	0.3189	9999	'DBL-G0847-WO'		
FNSL-Itera 02G1014		0 11G	G10_014			Non Converged	0	0.44028	9999	'DBL-G0847-WO'		
FDNS 02G1014		0 11G	G10_014	'TO->FROM'	'NORTHWEST - TATONGA7	345.00 345KV CKT 1'	1195	0.19378	96	'DBL-MEDLO-WI'		
FDNS 02G1014		0 11G	G10_014	'TO->FROM'	'FINNEY SWITCHING STATION - STEVENSCO	345.00	1052	0.47916	133.3729	'DBL-HIT-G084'		

SOLUTION GROUP	SCENARI	SEASON	SOURCE	DIRECTION	MONITORED ELEMENT	COMMON NAME	RATEB	TDF	TC%	LOAD	CONTINGENCY	NAME
FDNS	02G1014	0 11G	G10_014	TO->FROM	'NORTHWEST - TATONGA7	345.00 345KV CKT 1'	1195	0.21641	95.4	'DBL-WOOD-MED'		
FDNS	02G1014	0 11G	G10_014	TO->FROM	'FINNEY SWITCHING STATION - STEVENSCO	345.00	1052	0.29115	96.9	'DBL-WOOD-MED'		
FDNS	02G1014	2 11G	G10_014	TO->FROM	'NORTHWEST - TATONGA7	345.00 345KV CKT 1'	1195	0.19904	97.6	'DBL-MEDLO-WI'		
FDNS	02G1014	2 11G	G10_014	TO->FROM	'FINNEY SWITCHING STATION - STEVENSCO	345.00	1052	0.28377	97.6	'DBL-G0847-WO'		
FDNS	02G1014	2 11G	G10_014	TO->FROM	'NORTHWEST - TATONGA7	345.00 345KV CKT 1'	1195	0.22768	98.3	'DBL-WOOD-MED'		
FDNS	2	0 11G	G10_014	TO->FROM	'FINNEY SWITCHING STATION - STEVENSCO	345.00	1052	0.4805	128.0433	'DBL-HIT-G084'		
FNSL-Itera	2	0 11G	G10_014		Non Converged		1052	0.22922	76.82405	'FINNEY SWITCHING STATION - STEVENSCO	345.00	345KV CKT
FNSL-Blow	2	0 11G	G10_014		Non Converged		0	0.44151	9999	'DBL-G0847-WO'		
FDNS	2	2 11G	G10_014	TO->FROM	'NORTHWEST - TATONGA7	345.00 345KV CKT 1'	1195	0.19964	96.1	'DBL-MEDLO-WI'		
FDNS	2	2 11G	G10_014	TO->FROM	'NORTHWEST - TATONGA7	345.00 345KV CKT 1'	1195	0.22836	96.5	'DBL-WOOD-MED'		
FNSL-Itera	2	2 11G	G10_014		Non Converged		0	0.31905	9999	'DBL-G0847-WO'		
FNSL-Itera 02ALL		0 11G	G10_014		Non Converged		0	0.14281	9999	'SPP-SWPS-02'		
FNSL-Itera 02ALL		0 11G	G10_014		Non Converged		0	0.12419	9999	'DBL-G0847-WO'		
FNSL-Itera 02ALL		0 11G	G10_014		Non Converged		441	0.10569	56.03129	'STLN-DEMARC6230.00 - SWEETWT6	230.00	230KV CKT 1'
FNSL-Itera 02ALL		0 11G	G10_014		Non Converged		0	0.08073	9999	'ATC_B2_8E2_G'		
FNSL-Itera 02ALL		0 11G	G10_014		Non Converged		0	0.08048	9999	'ATC_B2_8E2_G'		
FNSL-Itera 02ALL		0 11G	G10_014		Non Converged		0	0.07818	9999	'050 1'		
FNSL-Itera 02ALL		0 11G	G10_014		Non Converged		0	0.07547	9999	'ATC_B2_8E2'		
FNSL-Itera 02ALL		0 11G	G10_014		Non Converged		0	0.07379	9999	'050 2'		
FNSL-Itera 02ALL		0 11G	G10_014		Non Converged		441	0.07016	56.87944	'STATELINE INTERCHANGE - STLN-DEMARC6230.00	230KV	CKT
FNSL-Itera 02ALL		0 11G	G10_014		Non Converged		0	0.05481	9999	'ATC_B2_8E2_G'		
FNSL-Blow 02ALL		0 11G	G10_014		Non Converged		0	0.05272	9999	'050 1'		
FNSL-Itera 02ALL		0 11G	G10_014		Non Converged		0	0.04965	9999	'050 2'		
FNSL-Itera 02ALL		0 11G	G10_014		Non Converged		1052	0.04246	82.65054	'FINNEY SWITCHING STATION - STEVENSCO	345.00	345KV CKT
FNSL-Itera 02ALL		0 11G	G10_014		Non Converged		1052	0.034	97.33807	'FINNEY SWITCHING STATION - STEVENSCO	345.00	345KV CKT
FNSL-Itera 02ALL		0 11G	G10_014		Non Converged		0	0.03003	9999	'050 1'		
FNSL-Itera 02ALL		0 11G	G10_014		Non Converged		0	0.02881	9999	'ATC_B2_8E2'		
FNSL-Itera 02ALL		0 11G	G10_014		Non Converged		0	0.02545	9999	'SPP-SWPS-03'		
FNSL-Itera 02ALL		0 11G	G10_014		Non Converged		0	0.02264	9999	'050 1'		
FNSL-Itera 02ALL		0 11G	G10_014		Non Converged		0	0.0221	9999	'ATC_B2_8E2_G'		
FNSL-Itera 02ALL		0 11G	G10_014		Non Converged		0	0.02172	9999	'ATC_B2_8E2_G'		
FNSL-Blow 02ALL		0 11G	G10_014		Non Converged		1052	0.22103	97.33807	'FINNEY SWITCHING STATION - STEVENSCO	345.00	345KV CKT
FNSL-Blow 02ALL		0 11G	G10_014		Non Converged		0	0.44949	9999	'DBL-HIT-G084'		
FNSL-Blow 02ALL		0 11G	G10_014		Non Converged		0	0.42793	9999	'DBL-G0847-WO'		
FNSL-Itera 02ALL		2 11G	G10_014		Non Converged		1052	0.18928	82.65054	'FINNEY SWITCHING STATION - STEVENSCO	345.00	345KV CKT
FNSL-Itera 02ALL		2 11G	G10_014		Non Converged		0	0.30841	9999	'DBL-G0847-WO'		
FNSL-Blow 02G08110		0 11G	G10_014		Non Converged		0	0.4405	9999	'DBL-G0847-WO'		
FNSL-Itera 02G08110		0 11G	G10_014		Non Converged		0	0.08283	9999	'SPP-SWPS-02'		
FNSL-Itera 02G08110		0 11G	G10_014		Non Converged		441	0.04142	56.82947	'STLN-DEMARC6230.00 - SWEETWT6	230.00	230KV CKT 1'
FNSL-Itera 02G08110		0 11G	G10_014		Non Converged		441	0.04142	57.15012	'STATELINE INTERCHANGE - STLN-DEMARC6230.00	230KV	CKT
FNSL-Itera 02G08110		3 11G	G10_014		Non Converged		0	0.05248	9999	'SPP-SWPS-03'		
FNSL-Itera 02G0847		0 11G	G10_014		Non Converged		441	0.04139	57.61415	'STATELINE INTERCHANGE - STLN-DEMARC6230.00	230KV	CKT
FNSL-Itera 02G0847		0 11G	G10_014		Non Converged		0	0.43881	9999	'DBL-G0847-WO'		
FNSL-Itera 02G0847		0 11G	G10_014		Non Converged		0	0.08277	9999	'SPP-SWPS-02'		
FNSL-Itera 02G0847		0 11G	G10_014		Non Converged		441	0.04139	57.29366	'STLN-DEMARC6230.00 - SWEETWT6	230.00	230KV CKT 1'
FNSL-Itera 02G0847		0 11G	G10_014		Non Converged		351	0.03741	82.03278	'GRAPEVINE INTERCHANGE - NICHOLS STATION	230KV	CKT 1'
FNSL-Itera 02G0847		3 11G	G10_014		Non Converged		0	0.05245	9999	'SPP-SWPS-03'		
FNSL-Itera 02G1007		0 11G	G10_014		Non Converged		441	0.04144	56.55862	'STLN-DEMARC6230.00 - SWEETWT6	230.00	230KV CKT 1'
FNSL-Itera 02G1007		0 11G	G10_014		Non Converged		441	0.04144	56.87944	'STATELINE INTERCHANGE - STLN-DEMARC6230.00	230KV	CKT
FNSL-Itera 02G1007		0 11G	G10_014		Non Converged		1052	0.2291	77.23053	'FINNEY SWITCHING STATION - STEVENSCO	345.00	345KV CKT
FNSL-Itera 02G1007		0 11G	G10_014		Non Converged		0	0.44133	9999	'DBL-G0847-WO'		
FNSL-Itera 02G1007		0 11G	G10_014		Non Converged		0	0.08287	9999	'SPP-SWPS-02'		
FNSL-Itera 02G1007		2 11G	G10_014		Non Converged		0	0.3189	9999	'DBL-G0847-WO'		
FNSL-Itera 02G1007		3 11G	G10_014		Non Converged		0	0.05249	9999	'SPP-SWPS-03'		
FNSL-Itera 02G1014		0 11G	G10_014		Non Converged		0	0.44028	9999	'DBL-G0847-WO'		
FNSL-Itera 02G1014		0 11G	G10_014		Non Converged		0	0.08274	9999	'SPP-SWPS-02'		
FNSL-Itera 02G1014		0 11G	G10_014		Non Converged		441	0.04137	57.2667	'STLN-DEMARC6230.00 - SWEETWT6	230.00	230KV CKT 1'
FNSL-Itera 02G1014		0 11G	G10_014		Non Converged		351	0.0374	81.98898	'GRAPEVINE INTERCHANGE - NICHOLS STATION	230KV	CKT 1'
FNSL-Itera 02G1014		0 11G	G10_014		Non Converged		441	0.04137	57.58744	'STATELINE INTERCHANGE - STLN-DEMARC6230.00	230KV	CKT
FNSL-Blow 02G1014		0 11G	G10_014		Non Converged		0	0.60001	9999	'DBL-G0847-WO'		
FNSL-Itera 02G1014		2 11G	G10_014		Non Converged		1195	0.04519	41.41769	'LAWTON EASTSIDE - OKLAUNION	345KV	CKT 1'
FNSL-Itera 02G1014		3 11G	G10_014		Non Converged		0	0.05243	9999	'SPP-SWPS-03'		
FNSL-Itera	2	0 11G	G10_014		Non Converged		441	0.0415	56.03129	'STLN-DEMARC6230.00 - SWEETWT6	230.00	230KV CKT 1'
FNSL-Itera	2	0 11G	G10_014		Non Converged		441	0.0415	56.34883	'STATELINE INTERCHANGE - STLN-DEMARC6230.00	230KV	CKT
FNSL-Itera	2	0 11G	G10_014		Non Converged		1052	0.22922	76.82405	'FINNEY SWITCHING STATION - STEVENSCO	345.00	345KV CKT
FNSL-Blow	2	0 11G	G10_014		Non Converged		0	0.44151	9999	'DBL-G0847-WO'		
FNSL-Itera	2	0 11G	G10_014		Non Converged		0	0.083	9999	'SPP-SWPS-02'		

SOLUTION GROUP	SCENARI	SEASON	SOURCE	DIRECTION	MONITORED ELEMENT	COMMON NAME	RATEB	TDF	TC%	LOAD	CONTINGENCY	NAME
FNSL-Itera	2	2	11G		G10_014	Non Converged	0	0.31905	9999	'DBL-G0847-WO'		
FNSL-Itera	2	3	11G		G10_014	Non Converged	0	0.0526	9999	'SPP-SWPS-03'		
FNSL-Blow 03ALL		0	11G		G10_014	Non Converged	0	0.18388	9999	'DBL-MEDLO-WI'		
FNSL-Itera	6	0	11G		G10_014	Non Converged	0	0.04674	9999	'SPP-SWPS-03'		
FNSL-Itera 02ALL		0	11G		G10_015	Non Converged	0	0.14287	9999	'SPP-SWPS-02'		
FNSL-Itera 02ALL		0	11G		G10_015	Non Converged	1052	0.12459	82.65054	'FINNEY SWITCHING STATION - STEVENSCO	345.00	345KV CK'
FNSL-Itera 02ALL		0	11G		G10_015	Non Converged	0	0.10607	9999	'DBL-G0847-WO'		
FNSL-Itera 02ALL		0	11G		G10_015	Non Converged	0	0.08073	9999	'ATC_B2_8E2_G'		
FNSL-Itera 02ALL		0	11G		G10_015	Non Converged	0	0.08048	9999	'ATC_B2_8E2_G'		
FNSL-Itera 02ALL		0	11G		G10_015	Non Converged	0	0.07819	9999	'050 1'		
FNSL-Itera 02ALL		0	11G		G10_015	Non Converged	0	0.07547	9999	'ATC_B2_8E2'		
FNSL-Itera 02ALL		0	11G		G10_015	Non Converged	0	0.0738	9999	'050 2'		
FNSL-Itera 02ALL		0	11G		G10_015	Non Converged	441	0.07016	56.55862	'STLN-DEMARC6230.00 - SWEETWT6	230.00	230KV CKT 1'
FNSL-Itera 02ALL		0	11G		G10_015	Non Converged	0	0.05482	9999	'ATC_B2_8E2_G'		
FNSL-Blow 02ALL		0	11G		G10_015	Non Converged	0	0.05275	9999	'050 1'		
FNSL-Itera 02ALL		0	11G		G10_015	Non Converged	0	0.04966	9999	'050 2'		
FNSL-Itera 02ALL		0	11G		G10_015	Non Converged	0	0.04254	9999	'DBL-G0847-WO'		
FNSL-Itera 02ALL		0	11G		G10_015	Non Converged	351	0.0374	81.98898	'GRAPEVINE INTERCHANGE - NICHOLS STATION 230KV CKT 1'		
FNSL-Itera 02ALL		0	11G		G10_015	Non Converged	0	0.0301	9999	'050 1'		
FNSL-Itera 02ALL		0	11G		G10_015	Non Converged	0	0.02889	9999	'ATC_B2_8E2'		
FNSL-Itera 02ALL		0	11G		G10_015	Non Converged	0	0.02555	9999	'SPP-SWPS-03'		
FNSL-Itera 02ALL		0	11G		G10_015	Non Converged	1052	0.02273	82.65054	'FINNEY SWITCHING STATION - STEVENSCO	345.00	345KV CK'
FNSL-Itera 02ALL		0	11G		G10_015	Non Converged	0	0.0221	9999	'ATC_B2_8E2_G'		
FNSL-Itera 02ALL		0	11G		G10_015	Non Converged	0	0.02173	9999	'ATC_B2_8E2_G'		
FNSL-Blow 03ALL		0	11G		G10_015	Non Converged	0	0.41281	9999	'DBL-SPRVL-CO'		
FNSL-Blow 03ALL		0	11G		G10_015	Non Converged	0	0.41281	9999	'DBL-COM-MEDL'		
FNSL-Blow 03ALL		0	11G		G10_015	Non Converged	0	0.2398	9999	'DBL-MEDLO-WI'		
FDNS	3	0	11G		G10_016	'FROM->TO'	184	0.99432	115.492	'BASE CASE'		
FDNS	3	0	11G		G10_016	'FROM->TO'	184	0.99432	115.492	'BASE CASE'		
FDNS	3	2	11G		G10_016	'FROM->TO'	184	0.99432	115.4798	'BASE CASE'		
FDNS	3	2	11G		G10_016	'FROM->TO'	184	0.99432	115.4798	'BASE CASE'		
FDNS	00G10_016	0	11SP		G10_016	'FROM->TO'	184	0.99478	147.3444	'BASE CASE'		
FDNS	00G10_016	0	11WP		G10_016	'FROM->TO'	184	0.99287	147.795	'BASE CASE'		
FDNS	00G10_016	0	16SP		G10_016	'FROM->TO'	184	0.99519	147.1187	'BASE CASE'		
FDNS	00G10_016	0	16WP		G10_016	'FROM->TO'	184	0.99348	147.7319	'BASE CASE'		
FDNS	00G10_016	0	11SP		G10_016	'FROM->TO'	184	0.99478	147.3444	'BASE CASE'		
FDNS	00G10_016	0	11WP		G10_016	'FROM->TO'	184	0.99287	147.795	'BASE CASE'		
FDNS	00G10_016	0	16SP		G10_016	'FROM->TO'	184	0.99519	147.1187	'BASE CASE'		
FDNS	00G10_016	0	16WP		G10_016	'FROM->TO'	184	0.99348	147.7319	'BASE CASE'		
FDNS	03G1016	0	11G		G10_016	'FROM->TO'	184	0.99291	144.1567	'BASE CASE'		
FDNS	03G1016	0	11G		G10_016	'FROM->TO'	184	0.99291	110.372	'DBL-SPRVL-CO'		
FDNS	03G1016	0	11G		G10_016	'FROM->TO'	184	0.99291	110.4035	'DBL-COM-MEDL'		
FDNS	03G1016	0	11G		G10_016	'FROM->TO'	184	0.99291	144.1567	'BASE CASE'		
FDNS	03G1016	0	11G		G10_016	'FROM->TO'	184	0.99291	110.372	'DBL-SPRVL-CO'		
FDNS	03G1016	0	11G		G10_016	'FROM->TO'	184	0.99291	110.4035	'DBL-COM-MEDL'		
FNSL-Itera 02ALL		0	11G		G10_016	Non Converged	1052	0.14125	82.65054	'FINNEY SWITCHING STATION - STEVENSCO	345.00	345KV CK'
FNSL-Itera 02ALL		0	11G		G10_016	Non Converged	0	0.12318	9999	'DBL-G0847-WO'		
FNSL-Itera 02ALL		0	11G		G10_016	Non Converged	441	0.10562	56.55862	'STLN-DEMARC6230.00 - SWEETWT6	230.00	230KV CKT 1'
FNSL-Itera 02ALL		0	11G		G10_016	Non Converged	0	0.08072	9999	'ATC_B2_8E2_G'		
FNSL-Itera 02ALL		0	11G		G10_016	Non Converged	0	0.08042	9999	'ATC_B2_8E2_G'		
FNSL-Itera 02ALL		0	11G		G10_016	Non Converged	0	0.07818	9999	'050 1'		
FNSL-Itera 02ALL		0	11G		G10_016	Non Converged	0	0.07547	9999	'ATC_B2_8E2'		
FNSL-Itera 02ALL		0	11G		G10_016	Non Converged	0	0.07379	9999	'050 2'		
FNSL-Itera 02ALL		0	11G		G10_016	Non Converged	441	0.07014	57.15012	'STALINE INTERCHANGE - STLN-DEMARC6230.00 230KV CKT		
FNSL-Itera 02ALL		0	11G		G10_016	Non Converged	0	0.05481	9999	'ATC_B2_8E2_G'		
FNSL-Blow 02ALL		0	11G		G10_016	Non Converged	0	0.0526	9999	'SPP-SWPS-03'		
FNSL-Itera 02ALL		0	11G		G10_016	Non Converged	0	0.04964	9999	'050 2'		
FNSL-Itera 02ALL		0	11G		G10_016	Non Converged	1052	0.04207	77.23053	'FINNEY SWITCHING STATION - STEVENSCO	345.00	345KV CK'
FNSL-Itera 02ALL		0	11G		G10_016	Non Converged	0	0.03155	9999	'ATC_B2_8E2_G'		
FNSL-Itera 02ALL		0	11G		G10_016	Non Converged	0	0.03002	9999	'050 1'		
FNSL-Itera 02ALL		0	11G		G10_016	Non Converged	0	0.02869	9999	'TRF-STEGALL'		
FNSL-Itera 02ALL		0	11G		G10_016	Non Converged	0	0.02544	9999	'SPP-SWPS-03'		
FNSL-Itera 02ALL		0	11G		G10_016	Non Converged	0	0.02263	9999	'050 1'		
FNSL-Itera 02ALL		0	11G		G10_016	Non Converged	441	0.02205	56.55862	'STLN-DEMARC6230.00 - SWEETWT6	230.00	230KV CKT 1'
FNSL-Blow 00G10_016		0	16SP		G10_016	Non Converged	0	0.03216	9999	'TRF-STEGALL'		
FNSL-Blow 00G10_016		0	16WP		G10_016	Non Converged	0	0.03016	9999	'TRF-STEGALL'		
FNSL-Blow	0	0	16SP		G10_016	Non Converged	0	0.03229	9999	'TRF-STEGALL'		

