



***Facility Study
For
Generation Interconnection
Request
GEN-2009-062***

***SPP Generation
Interconnection***

(#GEN-2009-062)

May 2011

Summary

Southwest Power Pool performed the following Study for Generation Interconnection request GEN-2009-062. The request for interconnection was placed with SPP in accordance with SPP's Open Access Transmission Tariff, which covers new generation interconnections on SPP's transmission system.

Pursuant to the tariff, SPP performed this Facility Study of the generation interconnection request to satisfy the Facility Study Agreement executed by the requesting customer and SPP.

Interconnection Customer Interconnection Facilities

The Interconnection Customer will be responsible for the 115 kV transmission line from the point of interconnection, the Hugoton 115kV Substation, to its 115/13.8 kV substation that will contain its 115/13.8 kV transformer.

Transmission Owner Interconnection Facilities and Non Shared Network Upgrades

Per the following Facility Study, the Interconnection Customer is responsible for **\$2,000,000** of Transmission Owner Interconnection Facilities and non-shared network upgrades.

Shared Network Upgrades

The interconnection customer was studied within the DISIS-2010-001-1 Impact Restudy. At this time, the Interconnection Customer is allocated the following cost for shared network upgrades:

Upgrade	Allocated Cost
Post Rock 345/230/13.8kV Transformer Ckt 2 DISIS-2010-001 Restudy	\$183,127
Spearville 345/115/13.8kV Transformer Ckt 1 New 345/115kV Spearville Transformer	\$3,745,000
TOTAL	\$3,928,127

If higher queued interconnection customers withdraw from the queue, suspend or terminate their LGIA, restudies will have to be conducted to determine the Interconnection Customer's allocation of shared network upgrades. All studies have been conducted on the basis of higher queued interconnection requests and the upgrades associated with those higher queued interconnection requests being placed in service.

Other Network Upgrades

Certain Network Upgrades that are not the cost responsibility of the Customer are required for Interconnection. These Network Upgrades include:

1. Axtel - Post Rock 345kV transmission line,
2. Comanche - Medicine Lodge double circuit 345kV transmission line,
3. Spearville - Comanche double circuit 345kV transmission line, and
4. Medicine Lodge - Wichita double circuit 345kV transmission line.

The complete set of network upgrades is not scheduled to be in service until December 31, 2014. Depending upon the status of higher or equally queued customers, the Interconnection Customer's in service date may be delayed until the in service date of these Network Upgrades.

Executive Summary

<OMITTED TEXT> (Customer) has requested a Facility Study under the Southwest Power Pool Open Access Transmission Tariff (OATT) for interconnecting a 115 MW steam powered generation facility in Stevens County, Kansas to the transmission system of Sunflower Electric Power Corporation (SUNC). The steam powered generation facility will interconnect into the existing Hugoton 115 kV Substation.

SUNC will add a 115 kV breaker to the existing Spearville substation and terminate the GEN-2009-062 generation facility. The Interconnection Customer's non shared network upgrades and interconnection facilities are estimated at \$2,000,000.

.

1. Introduction

<OMITTED TEXT> (Customer) has requested a Facility Study under the Southwest Power Pool Open Access Transmission Tariff (OATT) for interconnecting a 115 MW steam powered generation facility in Stevens County, Kansas to the transmission system of Sunflower Electric Power Corporation (SUNC). The steam powered generation facility will interconnect into the existing Hugoton 115kV Substation.

2. Interconnection Facilities and Network Upgrades

The cost for the Interconnection Facilities and Network Upgrades is listed below in Table 1. The one-line diagram is shown in Figure 1.

Table 1: Required Interconnection Facilities and Non Shared Network Upgrades

Project	Description	Estimated Cost
1	SUNC-add 115 kV breaker to the existing Spearville substation, and terminate GEN-2009-062.	\$2,000,000
	Total:	\$2,000,000

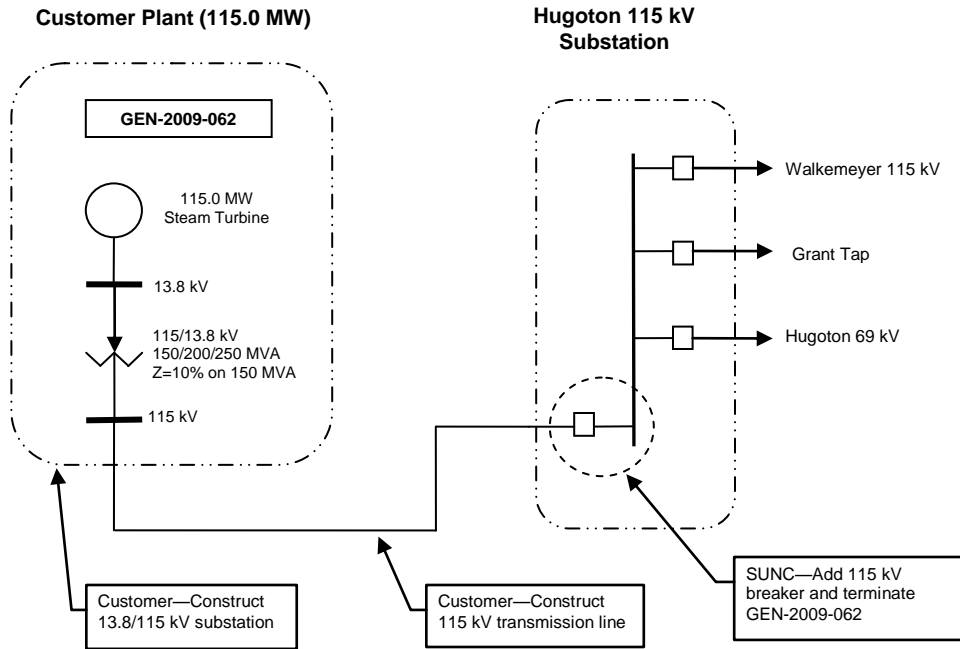

Figure 1. Interconnection Configuration for GEN-2009-062

2.1. Customer Facilities – The Customer will be responsible for its Generating Facility and its 115/13.8 kV substation that will contain its 115/13.8 kV transformer.

3. Conclusion

The Interconnection Customer’s interconnection facilities are estimated at **\$2,000,000**.