



**Feasibility Study
For
Generation Interconnection
Request
GEN-2007-038**

SPP Tariff Studies
(#GEN-2007-038)

March, 2008

Executive Summary

<OMITTED TEXT> (Customer) has requested a Feasibility Study for the purpose of interconnecting 200 MW of wind generation within the control area of Sunflower Electric Power Corporation (SUNC) located in Ford County, Kansas. The proposed interconnection point is at the existing Spearville (SUNC) 345 kV substation, owned by SUNC. The proposed in-service date is October, 2012.

Power flow analysis has indicated that for the powerflow cases studied, it is possible to interconnect the 200 MW of generation with transmission system reinforcements within the local transmission system. The need for reactive compensation for this interconnection request will be evaluated in the Impact Study based on the wind turbine manufacturer and type requested by the Customer. Dynamic Stability studies performed as part of the System Impact Study will provide additional guidance as to whether the required reactive compensation can be static or a portion must be dynamic (such as a SVC).

The Feasibility Study for GEN-2007-036 proposed to add a line terminal and two 345 kV circuit breakers on the existing Spearville (SUNC) substation. An addition of 200 MW at the GEN-2007-036 substation does not require an additional line terminal on the Spearville (SUNC) 345 kV substation.

There are no additional costs to interconnect this 200MW at the same point as GEN-2007-036. These costs are shown in Tables 1 and 2. This cost does not include building the 345 kV line from the Customer 345/34.5 kV collector substation into the point of interconnection. This cost also does not include the Customer's 345/34.5 kV collector substation or possible need for reactive compensation. Network constraints in the Sunflower Electric Power Corporation (SUNC) transmission systems that were identified are shown in Table 3. These Network constraints will have to be verified with a Transmission Service Request (TSR) and associated studies. Network Constraints are in the local area of the new generation when this generation is sunk throughout the SPP footprint for the Energy Resource (ER) Interconnection request. With a defined source and sink in a Transmission Service Request, this list of Network Constraints will be refined and expanded to account for all Network Upgrade requirements.

In Table 4, a value of Available Transfer Capability (ATC) associated with each overloaded facility is included. These values may be used by the Customer for future analyses including the determination of lower generation capacity levels that may be installed. When transmission service associated with this interconnection is evaluated, the loading of the facilities listed in this table may be greater due to higher priority reservations. If the loading of a facility is higher, the level of ATC will be lower.

The proposed 345kV line from Spearville – Comanche – Wichita was included in this study. This 345kV line has been assigned to the Customer for GEN-2005-012 as a stability requirement, since SPP has not issued a Notice to Construct to a transmission owner for this line. In the event that GEN-2005-012 withdraws from the queue, the cost of this 345kV line could be assigned to the Customer. In the Impact Study and subsequent restudies, it will be determined if the Customer can be interconnected along this proposed 345kV line in lieu of an interconnection at Spearville.

There are several other proposed generation additions in the general area of the Customer's facility. It was assumed in this preliminary analysis that not all of these other projects within the SPP control areas will be in service. Those previously queued projects that have advanced to nearly complete phases were

included in this Feasibility Study. In the event that another request for a generation interconnection with a higher priority withdraws, then this request may have to be re-evaluated to determine the local Network Constraints.

The required interconnection costs listed in Tables 1 and 2 and other upgrades associated with Network Constraints do not include all costs associated with the deliverability of the energy to final customers. These costs are determined by separate studies if the Customer submits a Transmission Service Request through Southwest Power Pool's OASIS.

Contents

Introduction	5
Interconnection Facilities	5
Interconnection Estimated Costs	6
Powerflow Analysis	7
Powerflow Analysis Methodology	8
Powerflow Results.....	9
Conclusion	12
Appendix A: Point of Interconnection Area Map.....	13

Tables

Table 1: Direct Assignment Facilities	6
Table 2: Required Interconnection Network Upgrade Facilities.....	6
Table 3: Network Constraints.....	9
Table 4: Contingency Analysis	10

Figures

Figure 1: Proposed Method of Interconnection	5
Figure 2: Point of Interconnection Area Map	13

Introduction

<OMITTED TEXT> (Customer) has requested a Feasibility Study for the purpose of interconnecting 200 MW of wind generation within the control area of Sunflower Electric Power Electric (SUNC) located in Ford County, Kansas. The proposed interconnection point is at the existing Spearville (SUNC) 345 kV substation, owned by SUNC. The proposed in-service date is October, 2012.

Interconnection Facilities

The primary objective of this study is to identify the system problems associated with connecting the generation to the area transmission system. The Feasibility and other subsequent Interconnection Studies are designed to identify attachment facilities, Network Upgrades and other Direct Assignment Facilities needed to accept power into the grid at the interconnection receipt point.

The Feasibility Study for GEN-2007-036 proposed to add a line terminal and two 345 kV circuit breakers on the existing Spearville (SUNC) substation. An addition of 200 MW at the substation for GEN-2007-036 does not require an additional line terminal on the Spearville (SUNC) 345 kV substation.

Other Network Constraints in the Sunflower Electric Power Corporation (SUNC) transmission systems that were identified are shown in Table 3. With a defined source and sink in a Transmission Service Request (TSR), this list of Network Constraints will be refined and expanded to account for all Network Upgrade requirements.

A preliminary one-line drawing of the interconnection and direct assigned facilities are shown in Figure 1.

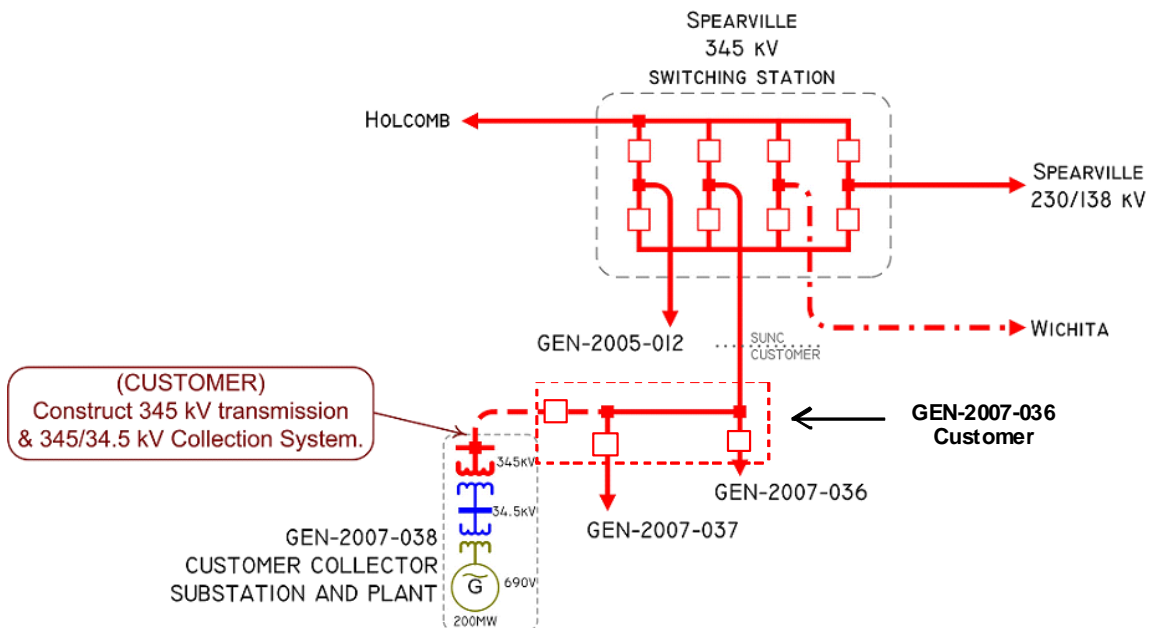

Figure 1: Proposed Method of Interconnection

(Final design to be determined)

Interconnection Estimated Costs

There are no additional costs to interconnect this 200MW at the same point as GEN-2007-036. These costs are listed in Tables 1 and 2. These estimates will be refined during the development of the System Impact Study based on the final designs. This cost does not include building the Customer's 345 kV transmission line extending from the point of interconnection to serve its 345/34.5 kV collection facilities. This cost also does not include the Customer's 345/34.5 kV collector substation or the possible need for reactive compensation, all of which should be determined by the Customer. The Customer is responsible for these 345 kV – 34.5 kV facilities up to the point of interconnection.

The Customer has indicated a preference for interconnecting into the proposed Spearville – Comanche – Wichita 345kV line. Presently, this line is included in the SPP Expansion Plan as an economic upgrade. Since no formal Notice to Construct exists for the construction of this line, the line has been assigned to GEN-2005-012 as a upgrade required for stability. In the event that GEN-2005-012 withdraws from the queue, this line could be assigned to the Customer.

The costs of interconnecting the facility to the SPS transmission system are listed in Table 1 & 2. **These costs do not include any cost that might be associated with short circuit study results or dynamic stability study results.** These costs will be determined when and if a System Impact Study is conducted.

Table 1: Direct Assignment Facilities

FACILITY	ESTIMATED COST (2008 DOLLARS)
CUSTOMER – 345/34.5 kV substation facilities.	*
CUSTOMER – 345 kV line between Customer substation and GEN-2007-036 substation.	*
CUSTOMER – Possible reactive compensation to be determined during Impact Study	*
CUSTOMER – Right-of-Way for all Customer facilities.	*
TOTAL	*

* Estimates of cost to be determined.

Table 2: Required Interconnection Network Upgrade Facilities

FACILITY	ESTIMATED COST (2007 DOLLARS)
SUNC – add a new line terminal and one 345 kV circuit breaker to be built for generation request #GEN-2007-036 at the existing Spearville 345 kV substation. Work to include associated switches, control relaying, high speed communications, metering and related equipment and all related structures.	GEN-2007-036 Customer**
TOTAL	\$0.00

* Estimates of cost to be determined.

** Responsibility of Customer if GEN-2007-036 and GEN-2007-037 withdraw

Powerflow Analysis

A powerflow analysis was conducted for the facility using modified versions of the 2012 summer and winter peak models and the 2017 summer peak model. The output of the Customer's facility was offset in each model by a reduction in output of existing online SPP generation. This method allows the request to be studied as an Energy Resource (ER) Interconnection request. The proposed in-service date of the generation is October, 2012. The available seasonal models used were through the 2017 Summer Peak of which is the end of the current SPP planning horizon.

This analysis was conducted assuming that previous queued requests in the immediate area of this interconnect request were in service. This analysis was conducted assuming the proposed Spearville – Comanche – Wichita 345kV line is in service. There is no Notice to Construct between SPP and any other party to build this line. Presently, this line has been assigned to GEN-2005-012 interconnection customer. In the event that GEN-2005-012 withdraws from the queue, the Customer could be responsible for the cost of this line. The analysis of the Customer's project indicates that, given the requested generation level of 200 MW and location, additional criteria violations will occur on the existing SPS transmission systems under steady state and contingency conditions in the peak seasons. Table 3 lists these overloaded facilities.

In Table 4, a value of Available Transfer Capability (ATC) associated with each overloaded facility is included. These values may be used by the Customer to determine lower generation capacity levels that may be installed. When transmission service associated with this interconnection is evaluated, the loading of the facilities listed in this table may be greater due to higher priority reservations. When a facility is overloaded for more than one contingency, only the highest loading on the facility for each season is included in the table.

The need for reactive compensation will be determined during the Impact Study. The need for reactive compensation will be based on the Customer's choice of wind turbine make and manufacturer. Dynamic Stability studies performed as part of the System Impact Study will provide additional guidance as to whether the reactive compensation can be static or a portion must be dynamic (such as a SVC or STATCOM). It is possible that an SVC or STATCOM device will be required at the Customer facility because of FERC Order 661A Low Voltage Ride-Through Provisions (LVRT) which went into effect January 1, 2006. FERC Order 661A orders that wind farms stay on-line for 3-phase faults at the point of interconnection even if that requires the installation of a SVC or STATCOM device.

There are several other proposed generation additions in the general area of the Customer's facility. Some of the local projects that were previously queued were assumed to be in service in this Feasibility Study. Not all local projects that were previously queued and have advanced to nearly complete phases were included in this Feasibility Study. In the event that another request for a generation interconnection with a higher priority withdraws, then this request may have to be re-evaluated to determine the local Network Constraints.

Powerflow Analysis Methodology

The Southwest Power Pool (SPP) criteria states that: “The transmission system of the SPP region shall be planned and constructed so that the contingencies as set forth in the Criteria will meet the applicable NERC Planning Standards for System Adequacy and Security – Transmission System Table I hereafter referred to as NERC Table I) and its applicable standards and measurements”.

Using the created models and the ACCC function of PSS\E, single contingencies in portions or all of the modeled control areas of Sunflower Electric Power Corporation (SUNC), Missouri Public Service (MIPU), Westar Energy (WERE), Kansas City Power & Light (KCPL), West Plains (WEPL), Midwest Energy (MIDW), Oklahoma Gas and Electric (OKGE), American Electric Power West (AEPW), Grand River Dam Authority (GRDA), Southwestern Public Service Company (SPS), Western Farmers Electric Cooperative (WFEC) and other control areas were applied and the resulting scenarios analyzed. This satisfies the ‘more probable’ contingency testing criteria mandated by NERC and the SPP criteria.

Powerflow Results

Table 3: Network Constraints

AREA	OVERLOADED ELEMENT
MIDW/WEPL	ST JOHN - ST_JOHN 115KV CKT 1
OKGE	WOODRING (WOODRNG2) 345/138/13.8KV TRANSFORMER CKT 1
SPS	HARRINGTON STATION - NICHOLS STATION 230KV CKT 1
SPS	HARRNG_MID6 230.00 - NICHOLS STATION 230KV CKT 2
SPS	POTTER COUNTY INTERCHANGE (POTTR CO) 345/230/13.2KV TRANSFORMER CKT 1
SPS/WEPL	TEXAS COUNTY INTERCHANGE PHASE SHIFT TFMR - EAST LIBERAL 115KV CKT 1
SUNC	HOLCOMB - PLYMELL 115KV CKT 1
SUNC	PIONEER TAP - PLYMELL 115KV CKT 1
SUNC/WEPL	SPEARVILLE (SPEARVL) 345/230/13.8KV TRANSFORMER CKT 1
WEPL	CIMARRON RIVER PLANT - NORTH LIBERAL TAP 115KV CKT 1
WEPL	CIMARRON RIVER TAP - CIMARRON RIVER PLANT 115KV CKT 1
WEPL	CIMARRON RIVER TAP - CUDAHY 115KV CKT 1
WEPL	CIMARRON RIVER TAP - EAST LIBERAL 115KV CKT 1
WEPL	CUDAHY - JUDSON LARGE 115KV CKT 1
WEPL	GREENSBURG - 2001-39A 115KV CKT 1
WEPL	GREENSBURG - SUN CITY 115KV CKT 1
WEPL	HAGGARD - WEST DODGE 115KV CKT 1
WEPL	HARPER - 2006-21T 138KV CKT 1
WEPL	HARPER - MILAN TAP 138KV CKT 1
WEPL	MEDICINE LODGE - 2006-21T 138KV CKT 1
WEPL	MEDICINE LODGE - PRATT 115KV CKT 1
WEPL	MEDICINE LODGE - SUN CITY 115KV CKT 1
WEPL	MEDICINE LODGE (MED-LDG4) 138/115/2.72KV TRANSFORMER CKT 1
WEPL	MULLERGREN - SPEARVILLE 230KV CKT 1
WEPL	PRATT - ST JOHN 115KV CKT 1
WEPL/MIDW	MULLERGREN - S HAYS6 230KV CKT 1
WERE	CHISHOLM - EVANS ENERGY CENTER NORTH 138KV CKT 1
WERE	CLEARWATER - GILL ENERGY CENTER WEST 138KV CKT 1
WERE/WEPL	CIRCLE - MULLERGREN 230KV CKT 1
WERE/WEPL	CLEARWATER - MILAN TAP 138KV CKT 1
MIDW	Midwest Energy
OKGE	Oklahoma Gas and Electric
SPS	Southwestern Public Service Company
SUNC	Sunflower Electric Power Corporation
WEPL	West Plains
WERE	Westar Energy

Table 4: Contingency Analysis

SEASON	OVERLOADED ELEMENT	RATING (MVA)	LOADING (%)	ATC (MW)	CONTINGENCY
12SP	MEDICINE LODGE - SUN CITY 115KV CKT 1	80	267	0	WICHITA - SPEARVILLE 345KV CKT 1
12SP	MULLERGREIN - SPEARVILLE 230KV CKT 1	355	256	0	WICHITA - SPEARVILLE 345KV CKT 1
12SP	HARPER - 2006-21T 138KV CKT 1	72	236	0	WICHITA - SPEARVILLE 345KV CKT 1
12SP	MEDICINE LODGE - PRATT 115KV CKT 1	80	182	0	HARPER - 2006-21T 138KV CKT 1
12SP	GREENSBURG - 2001-39A 115KV CKT 1	130	177	0	WICHITA - SPEARVILLE 345KV CKT 1
12SP	GREENSBURG - SUN CITY 115KV CKT 1	130	169	0	WICHITA - SPEARVILLE 345KV CKT 1
12SP	MULLERGREIN - S HAYS6 230KV CKT 1	147	168	0	WICHITA - SPEARVILLE 345KV CKT 1
12SP	HARPER - MILAN TAP 138KV CKT 1	96	159	0	WICHITA - SPEARVILLE 345KV CKT 1
12SP	SPEARVILLE (SPEARVL) 345/230/13.8KV TRANSFORMER CKT 1	336	154	0	MULLERGREIN - SPEARVILLE 230KV CKT 1
12SP	CUDAHY - JUDSON LARGE 115KV CKT 1	130	139	0	HOLCOMB - SPEARVILLE 345KV CKT 1
12SP	PRATT - ST JOHN 115KV CKT 1	80	136	0	HARPER - 2006-21T 138KV CKT 1
12SP	CIMARRON RIVER TAP - CUDAHY 115KV CKT 1	130	132	0	HOLCOMB - SPEARVILLE 345KV CKT 1
12SP	ST JOHN - ST_JOHN 115KV CKT 1	88	129	0	WICHITA - SPEARVILLE 345KV CKT 1
12SP	CLEARWATER - MILAN TAP 138KV CKT 1	110	124	0	WICHITA - SPEARVILLE 345KV CKT 1
12SP	POTTER COUNTY INTERCHANGE (POTTR CO) 345/230/13.2KV TRANSFORMER CKT 1	560	119	0	SPEARVILLE - 2007-25T 345KV CKT 1
12SP	HARRINGTON STATION - NICHOLS STATION 230KV CKT 1	635	116	0	HARRNG_MID6 230.00 - NICHOLS STATION 230KV CKT 2
12SP	HARRNG_MID6 230.00 - NICHOLS STATION 230KV CKT 2	635	116	0	HARRINGTON STATION - NICHOLS STATION 230KV CKT 1
12SP	CIRCLE - MULLERGREIN 230KV CKT 1	319	110	41	WICHITA - SPEARVILLE 345KV CKT 1
12SP	MEDICINE LODGE (MED-LDG4) 138/115/2.72KV TRANSFORMER CKT 1	65	111	75	WICHITA - SPEARVILLE 345KV CKT 1
12SP	CIMARRON RIVER PLANT - NORTH LIBERAL TAP 115KV CKT 1	115	104	113	CIMARRON RIVER TAP - EAST LIBERAL 115KV CKT 1
12SP	CIMARRON RIVER TAP - CIMARRON RIVER PLANT 115KV CKT 1	90	110	114	HOLCOMB - SPEARVILLE 345KV CKT 1
12SP	HOLCOMB - PLYMELL 115KV CKT 1	143	102	131	FLETCHER - HOLCOMB 115KV CKT 1
12WP	CLEARWATER - GILL ENERGY CENTER WEST 138KV CKT 1	110	103	139	WICHITA - SPEARVILLE 345KV CKT 1
12SP	TEXAS COUNTY INTERCHANGE PHASE SHIFT TFMR - EAST LIBERAL 115KV CKT 1	119	103	149	LAMAR - FINNEY 345KV CKT 1; FINNEY - POTTER 345KV CKT 1
12SP	MEDICINE LODGE - 2006-21T 138KV CKT 1	72	101	192	WICHITA - SPEARVILLE 345KV CKT 1
12WP	MEDICINE LODGE - SUN CITY 115KV CKT 1	80	273	0	WICHITA - SPEARVILLE 345KV CKT 1
12WP	HARPER - 2006-21T 138KV CKT 1	72	260	0	WICHITA - SPEARVILLE 345KV CKT 1
12WP	MULLERGREIN - SPEARVILLE 230KV CKT 1	355	213	0	WICHITA - SPEARVILLE 345KV CKT 1
12WP	MEDICINE LODGE - PRATT 115KV CKT 1	80	190	0	HARPER - 2006-21T 138KV CKT 1
12WP	HARPER - MILAN TAP 138KV CKT 1	96	182	0	WICHITA - SPEARVILLE 345KV CKT 1
12WP	MULLERGREIN - S HAYS6 230KV CKT 1	147	165	0	WICHITA - SPEARVILLE 345KV CKT 1
12WP	PRATT - ST JOHN 115KV CKT 1	80	160	0	HARPER - 2006-21T 138KV CKT 1
12WP	SPEARVILLE (SPEARVL) 345/230/13.8KV TRANSFORMER CKT 1	336	154	0	MULLERGREIN - SPEARVILLE 230KV CKT 1
12WP	CLEARWATER - MILAN TAP 138KV CKT 1	110	147	0	WICHITA - SPEARVILLE 345KV CKT 1
12WP	MEDICINE LODGE (MED-LDG4) 138/115/2.72KV TRANSFORMER CKT 1	65	134	0	WICHITA - SPEARVILLE 345KV CKT 1
12WP	GREENSBURG - SUN CITY 115KV CKT 1	130	130	0	WICHITA - SPEARVILLE 345KV CKT 1
12WP	ST JOHN - ST_JOHN 115KV CKT 1	88	127	0	WICHITA - SPEARVILLE 345KV CKT 1

TABLE 4: Contingency Analysis (continued)

SEASON	OVERLOADED ELEMENT	RATING (MVA)	LOADING (%)	ATC (MW)	CONTINGENCY
12WP	CLEARWATER - GILL ENERGY CENTER WEST 138KV CKT 1	110	124	0	MEDICINE LODGE - PRATT 115KV CKT 1
12WP	MEDICINE LODGE - 2006-21T 138KV CKT 1	72	122	0	WICHITA - SPEARVILLE 345KV CKT 1
12WP	CUDAHY - JUDSON LARGE 115KV CKT 1	130	118	0	HOLCOMB - SPEARVILLE 345KV CKT 1
12WP	GREENSBURG - 2001-39A 115KV CKT 1	130	138	37	WICHITA - SPEARVILLE 345KV CKT 1
12WP	HAGGARD - WEST DODGE 115KV CKT 1	90	111	102	WICHITA - SPEARVILLE 345KV CKT 1
12WP	CIMARRON RIVER TAP - CUDAHY 115KV CKT 1	130	107	107	HOLCOMB - SPEARVILLE 345KV CKT 1
12WP	CIMARRON RIVER TAP - CIMARRON RIVER PLANT 115KV CKT 1	90	104	147	HOLCOMB - SPEARVILLE 345KV CKT 1
17SP	MEDICINE LODGE - SUN CITY 115KV CKT 1	80	236	0	WICHITA - SPEARVILLE 345KV CKT 1
17SP	MULLERGREN - SPEARVILLE 230KV CKT 1	355	232	0	WICHITA - SPEARVILLE 345KV CKT 1
17SP	HARPER - 2006-21T 138KV CKT 1	72	227	0	WICHITA - SPEARVILLE 345KV CKT 1
17SP	MEDICINE LODGE - PRATT 115KV CKT 1	80	180	0	HARPER - 2006-21T 138KV CKT 1
17SP	MEDICINE LODGE - 2006-21T 138KV CKT 1	72	167	0	HARPER - 2006-21T 138KV CKT 1
17SP	MULLERGREN - S HAYS6 230KV CKT 1	147	164	0	WICHITA - SPEARVILLE 345KV CKT 1
17SP	GREENSBURG - 2001-39A 115KV CKT 1	130	159	0	WICHITA - SPEARVILLE 345KV CKT 1
17SP	HARPER - MILAN TAP 138KV CKT 1	96	152	0	WICHITA - SPEARVILLE 345KV CKT 1
17SP	CUDAHY - JUDSON LARGE 115KV CKT 1	130	150	0	HOLCOMB - SPEARVILLE 345KV CKT 1
17SP	GREENSBURG - SUN CITY 115KV CKT 1	130	150	0	WICHITA - SPEARVILLE 345KV CKT 1
17SP	SPEARVILLE (SPEARVL) 345/230/13.8KV TRANSFORMER CKT 1	336	146	0	MULLERGREN - SPEARVILLE 230KV CKT 1
17SP	CIMARRON RIVER TAP - CUDAHY 115KV CKT 1	130	144	0	HOLCOMB - SPEARVILLE 345KV CKT 1
17SP	PRATT - ST JOHN 115KV CKT 1	80	137	0	HARPER - 2006-21T 138KV CKT 1
17SP	CLEARWATER - GILL ENERGY CENTER WEST 138KV CKT 1	110	132	0	WICHITA - SPEARVILLE 345KV CKT 1
17SP	CIMARRON RIVER TAP - CIMARRON RIVER PLANT 115KV CKT 1	90	125	0	HOLCOMB - SPEARVILLE 345KV CKT 1
17SP	CLEARWATER - MILAN TAP 138KV CKT 1	110	118	0	WICHITA - SPEARVILLE 345KV CKT 1
17SP	ST JOHN - ST JOHN 115KV CKT 1	88	112	0	WICHITA - SPEARVILLE 345KV CKT 1
17SP	CHISHOLM - EVANS ENERGY CENTER NORTH 138KV CKT 1	382	109	0	BENTON - WICHITA 345KV CKT 1
17SP	HOLCOMB - PLYMELL 115KV CKT 1	143	108	0	FLETCHER - HOLCOMB 115KV CKT 1
17SP	WOODRING (WOODRNG2) 345/138/13.8KV TRANSFORMER CKT 1	360	102	0	CIMARRON - WOODRING 345KV CKT 1
17SP	POTTER COUNTY INTERCHANGE (POTTR CO) 345/230/13.2KV TRANSFORMER CKT 1	560	110	30	WICHITA - SPEARVILLE 345KV CKT 1
17SP	CIMARRON RIVER PLANT - NORTH LIBERAL TAP 115KV CKT 1	115	106	58	CIMARRON RIVER TAP - EAST LIBERAL 115KV CKT 1
17SP	PIONEER TAP - PLYMELL 115KV CKT 1	143	104	61	FLETCHER - HOLCOMB 115KV CKT 1
17SP	HARRINGTON STATION - NICHOLS STATION 230KV CKT 1	635	101	108	HARRNG_MID6 230.00 - NICHOLS STATION 230KV CKT 2
17SP	HARRNG_MID6 230.00 - NICHOLS STATION 230KV CKT 2	635	101	123	HARRINGTON STATION - NICHOLS STATION 230KV CKT 1
17SP	CIMARRON RIVER TAP - EAST LIBERAL 115KV CKT 1	120	103	131	CIMARRON RIVER PLANT - NORTH LIBERAL TAP 115KV CKT 1
17SP	MEDICINE LODGE (MED-LDG4) 138/115/2.72KV TRANSFORMER CKT 1	65	102	175	WICHITA - SPEARVILLE 345KV CKT 1

Note: When transmission service associated with this interconnection is evaluated, the loading of the facilities listed in this Table may be greater due to higher priority reservations. If the loading of a facility is higher, the level of ATC will be lower.

Conclusion

There are no additional costs to interconnect this 200MW at the same point as GEN-2007-036. At this time, the cost estimates for other Direct Assignment facilities including those in Tables 1 and 2 have not been defined by the Customer. In addition to the Customer's proposed interconnection facilities, the Customer will be responsible for installing reactive compensation in the Customer's substation for reactive support. As stated earlier, some but not all of the local projects that were previously queued are assumed to be in service in this Feasibility Study. The proposed Spearville-Comanche-Wichita 345kV line was included in this analysis. This line could eventually be the cost responsibility of the Customer. These costs exclude upgrades of other transmission facilities that were listed in Table 3 of which are Network Constraints.

In Table 4, a value of Available Transfer Capability (ATC) associated with each overloaded facility is included. These values may be used by the Customer to determine lower generation capacity levels that may be installed. When transmission service associated with this interconnection is evaluated, the loading of the facilities listed in this table may be greater due to higher priority reservations. When a facility is overloaded for more than one contingency, only the highest loading on the facility for each season is included in the table.

These interconnection costs do not include any cost that may be associated with short circuit or transient stability analysis. These studies will be performed if the Customer signs a System Impact Study Agreement. At the time of the System Impact Study, a better determination of the interconnection facilities may be available.

The required interconnection costs listed in Tables 1 and 2 and other upgrades associated with Network Constraints do not include all costs associated with the deliverability of the energy to final customers. These costs are determined by separate studies if the Customer submits a Transmission Service Request through Southwest Power Pool's OASIS.

Appendix A: Point of Interconnection Area Map

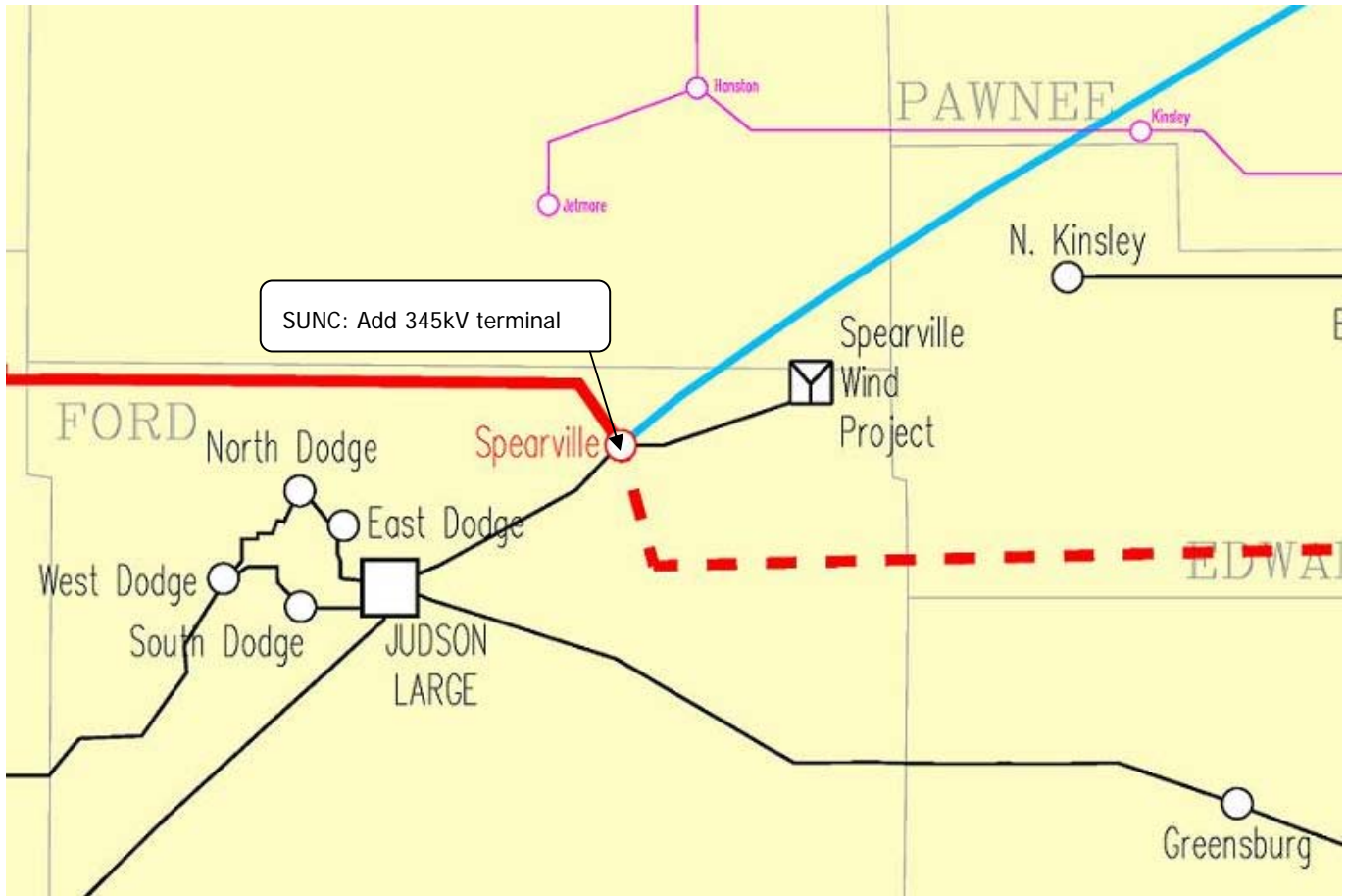

Figure 2: Point of Interconnection Area Map