



***Feasibility Study
For
Generation Interconnection
Request
GEN-2005-001***

***SPP Tariff Studies
(#GEN-2005-001)***

July 19, 2005

Executive Summary

<OMITTED TEXT> (Customer) has requested a Feasibility Study for the purpose of interconnecting 201MW of wind generation within the service territory of Kansas City Power & Light (KCPL) in Anderson County Kansas. The proposed point of interconnection is in the existing Centerville – Marmaton 161kV line at a new switching station to be located northeast of Kincaid, KS. This 161kV line is owned by KCPL. The proposed in-service date is November 1, 2006.

Power flow analysis has indicated that for the powerflow cases studied, it is possible to interconnect the 201MW of generation with transmission system reinforcements within the local KCPL, Empire District Electric (EMDE) and Westar (WERE) transmission systems. The requirements for interconnection consist of adding a 161kV switching station. This 161kV addition shall be constructed and maintained by KCPL. The Customer did not propose a specific 161kV line extending to serve its 161-34.5kV facilities. It is assumed that obtaining all necessary right-of-way for the necessary substation additions in the Centerville – Marmaton 161kV line will not be a significant expense.

The total cost for adding the 161kV switching station, the interconnection facility, is estimated at \$1,666,000. Other Network Constraints in the KCPL, EMDE and WERE systems that may be verified with a transmission service request and associated studies are listed in Table 3. These Network Constraints are in the local area of the new generation when this generation is sunk throughout the SPP footprint for the Energy Resource Interconnection request. With a defined source and sink in a Transmission Service Request, this list of Network Constraints will be refined and expanded to account for all Network Upgrade requirements. This cost does not include building 161kV line from the Customer substation into a new KCPL switching station. This cost does not include the Customer's 161-34.5kV substation.

In Table 4, a value of Available Transfer Capability (ATC) associated with each overloaded facility is included. These values may be used by the Customer for future analyses including the determination of lower generation capacity levels that may be installed. When transmission service associated with this interconnection is evaluated, the loading of the facilities listed in this table may be greater due to higher priority reservations. If the loading of a facility is higher, the level of ATC will be lower. When a facility is overloaded for more than 10 contingencies, then only the results with the 10 lowest values of ATC may be included in this table.

There are several other proposed generation additions in the general area of the Customer's facility. It was assumed in this preliminary analysis that these other projects within the WERE and Empire District Electric service territories will be in service. Those previously queued projects that have advanced to nearly complete phases were included in this Feasibility Study. In the event that another request for a generation interconnection with a higher priority withdraws, then this request may have to be re-evaluated to determine the local Network Constraints.

Introduction

<OMITTED TEXT> (Customer) has requested a feasibility study for the purpose of interconnecting 201MW of wind generation within the service territory of Kansas City Power & Light in Anderson County Kansas. The existing Centerville – Marmaton 161kV line is owned by KCPL, and the proposed generation interconnection is with KCPL. The proposed point of interconnection is at a new 161kV switching station. The proposed in-service date is November 1, 2006.

Interconnection Facilities

The primary objective of this study is to identify the system problems associated with connecting the plant to the area transmission system. The Feasibility and other subsequent Interconnection Studies are designed to identify attachment facilities, Network Upgrades and other direct assignment facilities needed to accept power into the grid at the interconnection receipt point.

The requirements for interconnection consist of adding a new 161kV switching station. This 161kV addition shall be constructed and maintained by KCPL. The Customer did not propose a route of its 161kV line to serve its 161-34.5kV facilities. It is assumed that obtaining all necessary right-of-way for the new KCPL 161kV switching station will not be a significant expense.

The total cost for KCPL to add a new 161kV switching station, the interconnection facility, in the Centerville – Marmaton 161kV line is estimated at \$1,666,000. Other Network Constraints in the EMDE, KCPL and WERE systems that were identified are listed in Table 3. These estimates will be refined during the development of the impact study based on the final designs. This cost does not include building 161kV line from the Customer substation into the new KCPL switching station. The Customer is responsible for this 161kV line up to the point of interconnection. This cost does not include the Customer's 161-34.5kV substation and the cost estimate should be determined by the Customer.

The costs of interconnecting the facility to the WERE transmission system are listed in Table 2. **These costs do not include any cost that might be associated with short circuit study results or dynamic stability study results.** These costs will be determined when and if a System Impact Study is conducted.

Table 1: Direct Assignment Facilities

Facility	ESTIMATED COST (2005 DOLLARS)
Customer – 161-34.5 kV Substation facilities.	*
Customer – 161kV line between Customer substation and new KCPL 161kV switching station.	*
Customer - Right-of-Way for Customer Substation & Line.	*
Total	*

Note: *Estimates of cost to be determined by Customer.

Table 2: Required Interconnection Network Upgrade Facilities

Facility	ESTIMATED COST (2005 DOLLARS)
KCPL - Add 3-breaker ring 161kV switching station in Centerville – Marmaton 161kV line.	\$1,666,000
Total	\$1,666,000

Table 4: Contingency Analysis Results

Facility	Model & Contingency	Facility Loading (% Rate B) Or Voltage (PU)	ATC (MW)	Date Required (M/D/Y)
CIRCLEVILLE - HOYT HTI SWITCHING JUNCTION 115kV	07SP, 57982-59199, KACP KACP - MIPU FLA , IATAN - ST JOE 345kV	100.2	189	6/1/2007
STILWELL - BUCYRUS 161kV	15SP, 57968-57981, KACP KACP , STILWELL - LACYGNE 345kV	114.4	50	6/1/2008
STILWELL - BUCYRUS 161kV	10SP, 57968-57981, KACP KACP , STILWELL - LACYGNE 345kV	114.1	55	
SUB 217 - FAIRPLAY EAST - SUB 368 - DADEVILLE EAST 69kV	15SP, 59478-59493, EMDE BOLIVAR , SUB 368 - DADEVILLE EAST - SUB 431 - BOLIVAR SOUTH 161kV	138.7	0	6/1/2011
SUB 217 - FAIRPLAY EAST - SUB 602 - BOLIVAR PLANT 69kV	15SP, 59478-59493, EMDE BOLIVAR , SUB 368 - DADEVILLE EAST - SUB 431 - BOLIVAR SOUTH 161kV	136.9	0	6/1/2011
SUB 367 - BOLIVAR SOUTHEAST - SUB 602 - BOLIVAR PLANT 69kV	15SP, 59478-59493, EMDE BOLIVAR , SUB 368 - DADEVILLE EAST - SUB 431 - BOLIVAR SOUTH 161kV	125.2	70	6/1/2011
SUB 368 - DADEVILLE EAST - DADEVILL 161-()kV	15SP, 59478-59493, EMDE BOLIVAR , SUB 368 - DADEVILLE EAST - SUB 431 - BOLIVAR SOUTH 161kV	103.1	129	6/1/2013
SUB 368 - DADEVILLE EAST - DADEVILL 69-()kV	15SP, 59478-59493, EMDE BOLIVAR , SUB 368 - DADEVILLE EAST - SUB 431 - BOLIVAR SOUTH 161kV	104.5	118	

Note: When transmission service associated with this interconnection is evaluated, the loading of the facilities listed in this table may be greater due to higher priority reservations. If the loading of a facility is higher, the level of ATC will be lower.

KACP: Kansas City Power & Light

Table 4: Contingency Analysis Results

Facility	Model & Contingency	Facility Loading (% Rate B) Or Voltage (PU)	ATC (MW)	Date Required (M/D/Y)
SUB 73 - BOLIVAR BURNS - BOL-BURN 161-()kV	15SP, 59478-59493, EMDE BOLIVAR , SUB 368 - DADEVILLE EAST - SUB 431 - BOLIVAR SOUTH 161kV	151.7	81	6/1/2011
SUB 73 - BOLIVAR BURNS - BOL-BURN 69-()kV	15SP, 59478-59493, EMDE BOLIVAR , SUB 368 - DADEVILLE EAST - SUB 431 - BOLIVAR SOUTH 161kV	139.8	98	
SUB 73 - BOLIVAR BURNS - SUB 367 - BOLIVAR SOUTHEAST 69kV	15SP, 59478-59493, EMDE BOLIVAR , SUB 368 - DADEVILLE EAST - SUB 431 - BOLIVAR SOUTH 161kV	116.0	136	6/1/2011
SUB 80 - MARSHFIELD JCT. - SUB 323 - BRIGHTON EAST 69kV	15SP, 59478-59493, EMDE BOLIVAR , SUB 368 - DADEVILLE EAST - SUB 431 - BOLIVAR SOUTH 161kV	102.4	189	6/1/2014

Note: When transmission service associated with this interconnection is evaluated, the loading of the facilities listed in this table may be greater due to higher priority reservations. If the loading of a facility is higher, the level of ATC will be lower.

Powerflow Analysis

A powerflow analysis was conducted for the facility using modified versions of the 2006 April, 2006 Winter Peak, 2007 and 2010 Summer and Winter Peak, and 2015 Summer Peak models. The output of the Customer's facility was offset in each model by a reduction in output of existing online SPP generation. The proposed in-service date of the generation is November 1, 2006. The available seasonal models used were through the 2015 Summer Peak of which is the end of the current SPP planning horizon.

The analysis of the Customer's project indicates that, given the requested generation level of 201MW and location, additional criteria violations will occur on the existing EMDE, KCPL and WERE facilities under steady state conditions in the peak seasons.

There are several other proposed generation additions in the general area of the Customer's facility. Local projects that were previously queued were assumed to be in service in this Feasibility Study. Those local projects that were previously queued and have advanced to nearly complete phases were included in this Feasibility Study.

Powerflow Analysis Methodology

The Southwest Power Pool (SPP) criteria states that: "The transmission system of the SPP region shall be planned and constructed so that the contingencies as set forth in the Criteria will meet the applicable *NERC Planning Standards* for System Adequacy and Security – Transmission System Table I hereafter referred to as NERC Table I) and its applicable standards and measurements".

Using the created models and the ACCC function of PSS\E, single contingencies in portions or all of the modeled control areas of American Electric Power West, Empire District Electric, Grand River Dam Authority, Kansas City Power & Light, OG&E Electric Services and Westar Energy were applied and the resulting scenarios analyzed. This satisfies the 'more probable' contingency testing criteria mandated by NERC and the SPP criteria.

Conclusion

The minimum cost of interconnecting the Customer project is estimated at \$1,666,000 for KCPL's interconnection Network Upgrade facilities listed in Table 2 excluding upgrades of other transmission facilities by EMDE, KCPL, WERE listed in Table 3 of which are Network Constraints. At this time, the cost estimates for other Direct Assignment facilities including those in Table 1 have not been defined by the Customer. As stated earlier, local projects that were previously queued are assumed to be in service in this Feasibility Study.

In Table 4, a value of Available Transfer Capability (ATC) associated with each overloaded facility is included. These values may be used by the Customer to determine lower generation capacity levels that may be installed. When transmission

service associated with this interconnection is evaluated, the loading of the facilities listed in this table may be greater due to higher priority reservations. When a facility is overloaded for more than 10 contingencies, then only the results with the 10 lowest values of ATC may be included in this table.

These interconnection costs do not include any cost that may be associated with short circuit or transient stability analysis. These studies will be performed if the Customer signs a System Impact Study Agreement.

The required interconnection costs listed in Table 2 and other upgrades associated with Network Constraints listed in Table 3 do not include all costs associated with the deliverability of the energy to final customers. These costs are determined by separate studies if the Customer requests transmission service through Southwest Power Pool's OASIS.

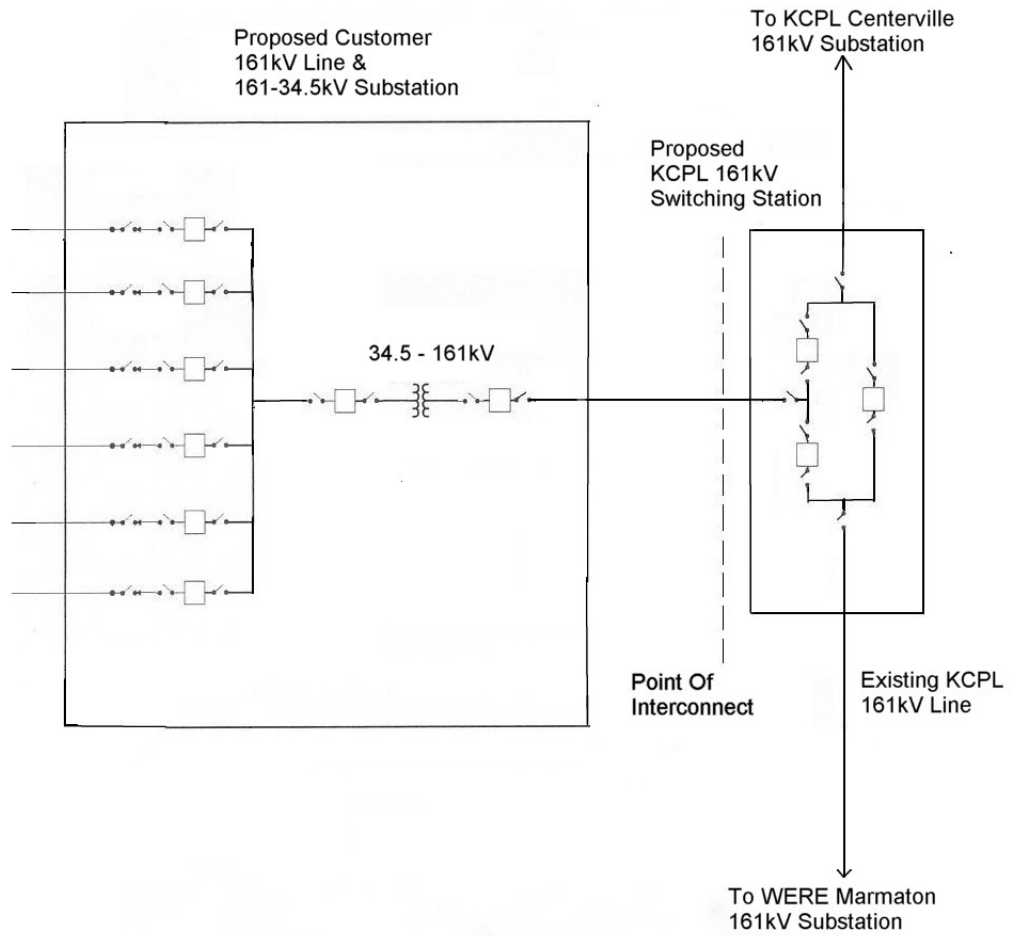

**Figure 1: Proposed Interconnection
(Final substation design to be determined)**

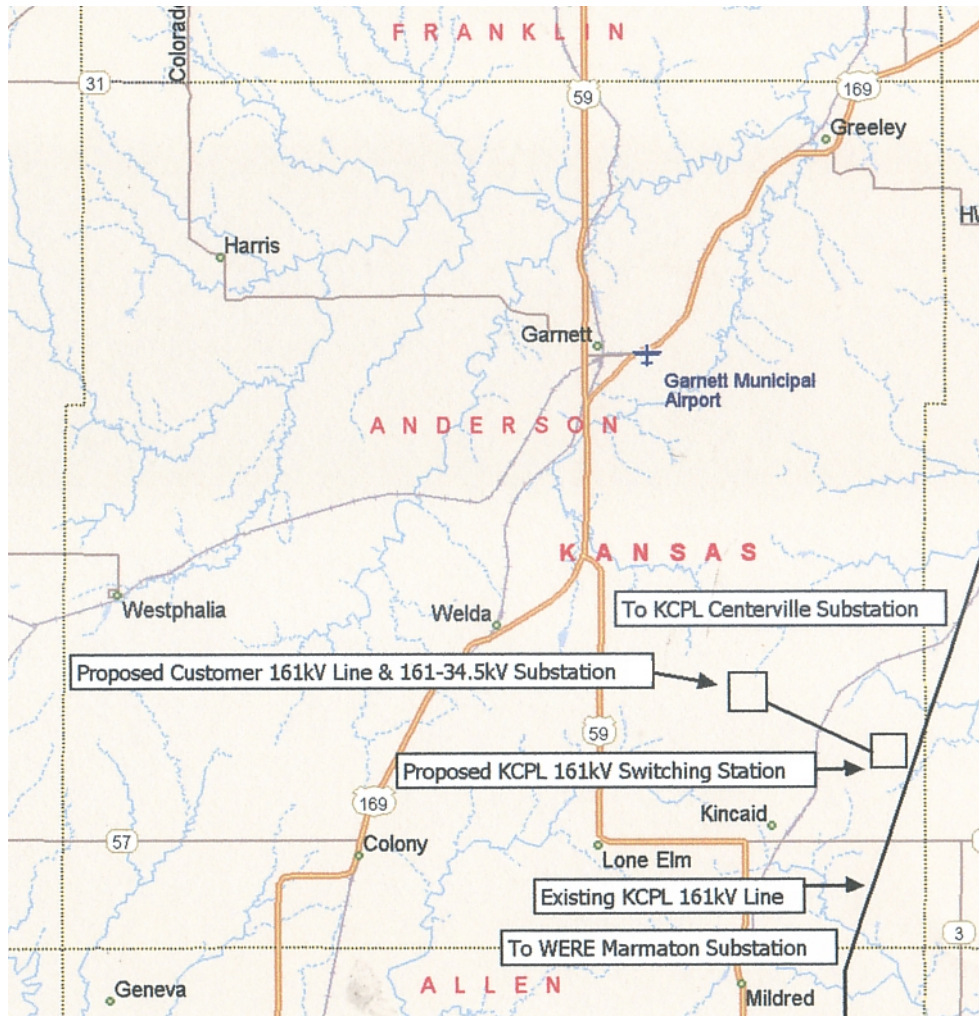

Figure 2: Map Of The Surrounding Area