



***Feasibility Study
For
Generation Interconnection
Request
GEN-2003-024***

***SPP Tariff Studies
(#GEN-2003-024)***

August 19, 2004

Executive Summary

<OMITTED TEXT> (Customer) has requested a feasibility study for the purpose of interconnecting 201MW of wind generation within the service territory of Westar Energy (WERE) in Morris County Kansas. The proposed point of interconnection is in the existing Morris County - Summit 230kV line at a new switching station located near Wilsey, KS. This 230kV line is owned by Westar Energy. The proposed in-service date is December 31, 2005.

Power flow analysis has indicated that for the powerflow cases studied, it is possible to interconnect the 201MW of generation with transmission system reinforcements within the local WERE transmission system. The requirements for interconnection consist of adding a 230kV switching station. This 230kV addition shall be constructed and maintained by WERE. The Customer did not propose a specific 230kV line extending to serve its 230-34.5kV facilities. It is assumed that obtaining all necessary right-of-way for the necessary substation additions in the Morris County - Summit 230kV line will not be a significant expense.

The total cost for adding the 230kV switching station, the interconnection facility, is estimated at \$3,400,000. Other Network Upgrades in the WERE system are required that are listed in Table 1. Therefore, the total estimated cost to the Customer is \$43,617,200. This cost does not include building 230kV line from the Customer substation into the new WERE Council Grove Switching Station. This cost does not include the Customer's 230-34.5kV substation.

In Table 3, a value of Available Transfer Capability (ATC) associated with each overloaded facility is included. These values may be used by the Customer for future analyses including the determination of lower generation capacity levels that may be installed with different financial characteristics given the cost of Network Upgrades. When transmission service associated with this interconnection is evaluated, the loading of the facilities listed in this table may be greater due to higher priority reservations. If the loading of a facility is higher, the level of ATC will be lower.

There are several other proposed generation additions in the general area of the Customer's facility. It was assumed in this preliminary analysis that all of these other projects within Midwest Energy's and WERE's service territory will be in service. Those previously queued projects that have advanced to nearly complete phases were included in this feasibility study.

Introduction

<OMITTED TEXT> (Customer) has requested a feasibility study for the purpose of interconnecting 201MW of wind generation within the service territory of Westar Energy in Morris County Kansas. The existing Morris County - Summit 230kV line is owned by WERE, and the proposed generation interconnect is with WERE. The proposed point of interconnection is at a new 230kV switching station. The proposed in-service date is December 31, 2005.

Interconnection Facilities

The primary objective of this study is to identify the system problems associated with connecting the plant to the area transmission system and estimated costs of system modifications needed to alleviate the system problems.

The Feasibility and other subsequent Interconnection Studies are designed to identify attachment facilities, Network Upgrades and other direct assignment facilities needed to accept power into the grid at the interconnection receipt point.

The requirements for interconnection consist of adding a 230kV switching station. This 230kV addition shall be constructed and maintained by WERE. The Customer did not propose a route of its 230kV line to serve its 230-34.5kV facilities. It is assumed that obtaining all necessary right-of-way for the new WERE 230kV switching station will not be a significant expense.

The total cost for WERE to add the new 230kV switching station, the interconnection facility, in the Morris County - Summit 230kV line is estimated at \$3,400,000. Other Network Upgrades in the WERE system are required that are listed in Table 1. Therefore, the total estimated cost to the Customer is \$43,617,200. These estimates will be refined during the development of the impact study based on the final designs. This cost does not include building 230kV line from the Customer substation into the new WERE switching station. The Customer is responsible for this 230kV line up to the point of interconnection. This cost does not include the Customer's 230-34.5kV substation and the cost estimate should be determined by the Customer.

The costs of interconnecting the facility to the WERE transmission system are listed in Table 1. **These costs do not include any cost that might be associated with short circuit study results or dynamic stability study results.** These costs will be determined when and if a System Impact Study is conducted.

Table 1: Network Upgrade Facilities

Facility	ESTIMATED COST (2004 DOLLARS)
WERE – Council Grove 230kV 3 breaker ring switching station addition in the existing Morris County - Summit 230kV line.	\$3,400,000
WERE – North American Philips - North American Philips Junction (South) 115kV rebuild of 0.88 miles and re-conductor with 1192.5 ACSR.	417,200
WERE - North American Philips Junction (South) - West McPherson 115kV CKT 2 tear down double circuit and build single circuit with 1192.5 ACSR.	7,800,000
WERE - Jeffrey Energy Center - Swissvale 345kV construction of new 50 mile line.	32,000,000
Total	\$43,617,200

Table 2: Direct Assignment Facilities

Facility	ESTIMATED COST (2004 DOLLARS)
Customer – 230-34.5 kV Substation facilities.	*
Customer - 230kV line between Customer substation and new WERE 230kV switching station.	*
Customer - Right-of-Way for Customer Substation & Line.	*
Total	*

Note: * Estimates of cost to be determined by Customer.

Table 3: Contingency Analysis Results

Facility	Contingency	Facility Loading (% Rate B) Or Voltage (PU)	ATC (MW)	Date Required (M/D/Y)
WERE – North American Philips - North American Philips Junction (South) 115kV rebuild of 0.88 miles and re-conductor with 1192.5 ACSR.	East McPherson - Summit 230kV	149.7	0	12/31/05
WERE - North American Philips Junction (South) - West McPherson 115kV CKT 2 tear down double circuit and build single circuit with 1192.5 ACSR.	East McPherson - Summit 230kV	141	0	12/31/05
WERE - Hoyt - Jeffrey Energy Center 345kV line. The network upgrade is the Jeffrey Energy Center - Swissvale 345kV construction of new 50 mile line.	Auburn Road - Jeffrey Energy Center 230kV	104.7	0	6/1/06
WERE - Swissvale 345-230kV transformer. The network upgrade is the Jeffrey Energy Center - Swissvale 345kV construction of new 50 mile line.	Lang - Morris County 345kV	101.4	184	12/1/10 Note (1)

Note: Listed loading of each facility is the highest value when an operating guide is not applicable.

When transmission service associated with this interconnection is evaluated, the loading of the facilities listed in this table may be greater due to higher priority reservations. If the loading of a facility is higher, the level of ATC will be lower.

(1) The network upgrade is required 6/1/2006 for an outage of the Auburn Road - Jeffrey Energy Center 230kV that results in overloading the Hoyt - Jeffrey Energy Center 345kV line.

Powerflow Analysis

A powerflow analysis was conducted for the facility using modified versions of the 2005 April, 2005, 2007 and 2010 Summer and Winter Peak models. The output of the Customer's facility was offset in each model by a reduction in output of existing online SPP generation. The proposed in-service date of the generator is December 31, 2005. The available seasonal models used were the 2005 April and 2005 through 2010 peak models. This is the end of the current SPP planning horizon.

The analysis of the Customer's project indicates that, given the requested generation level of 201MW and location, additional criteria violations will occur on the existing WERE facilities under steady state conditions in all seasons out to the end of SPP's planning horizon.

There are several other proposed generation additions in the general area of the Customer's facility. Previously queued projects were assumed to be in service in this feasibility study. Those previously queued projects that have advanced to nearly complete phases were included in this feasibility study.

Powerflow Analysis Methodology

The Southwest Power Pool (SPP) criteria states that: The transmission system of the SPP region shall be planned and constructed so that the contingencies as set forth in the Criteria will meet the applicable *NERC Planning Standards for System Adequacy and Security – Transmission System Table I* hereafter referred to as NERC Table I) and its applicable standards and measurements.

Using the created models and the ACCC function of PSS\E, single contingencies in the modeled control areas of Midwest Energy, Kansas City Power & Light, and Westar Energy were applied and the resulting scenarios analyzed. This satisfies the 'more probable' contingency testing criteria mandated by NERC and the SPP criteria.

Conclusion

The minimum cost of interconnecting the Customer project is estimated at \$43,617,200 for WERE's interconnection facilities including other transmission upgrades by WERE listed in Table 1 of which are Network Upgrades. At this time, the cost estimates for other Direct Assignment facilities have not been defined by the Customer. As stated earlier, previously queued projects were assumed to be in service in this feasibility study.

In Table 3, a value of Available Transfer Capability (ATC) associated with each overloaded facility is included. These values may be used by the Customer to determine lower generation capacity levels that may be installed with different financial characteristics given the cost of Network Upgrades. When transmission service associated with this interconnection is evaluated, the loading of the facilities listed in this table may be greater due to higher priority reservations.

These interconnection costs do not include any cost that may be associated with short circuit or transient stability analysis. These studies will be performed if the Customer signs a system impact study agreement.

The costs do not include any costs associated with the deliverability of the energy to final customers. These costs are determined by separate studies if the Customer requests transmission service through Southwest Power Pool's OASIS.

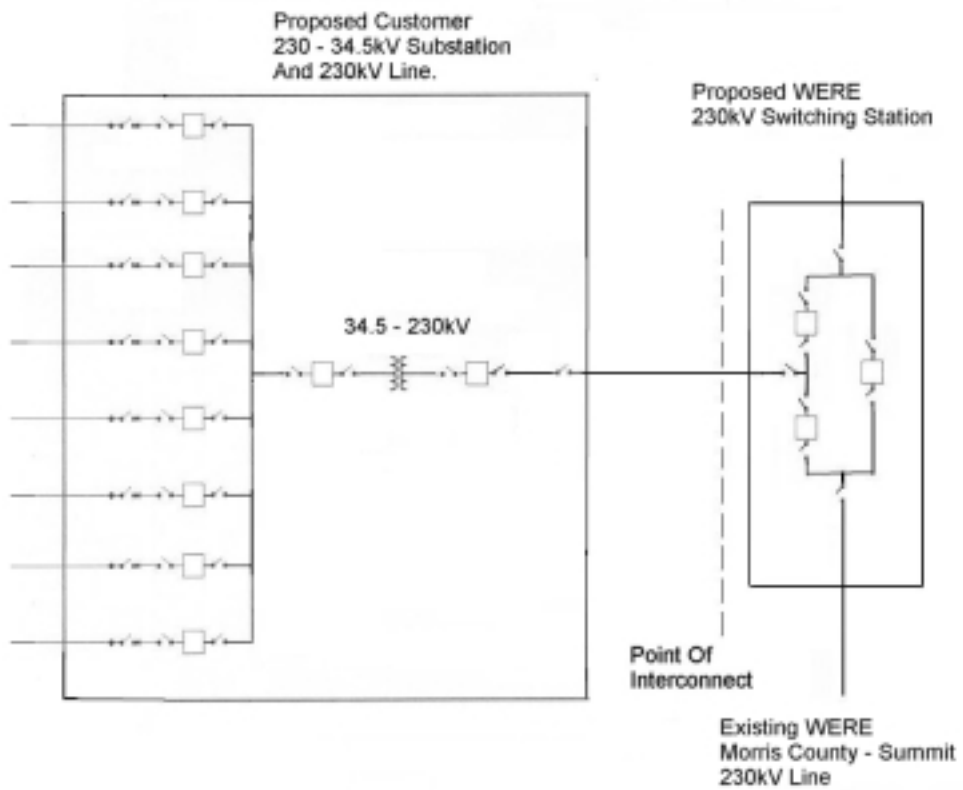

**Figure 1: Proposed Interconnection
(Final substation design to be determined)**

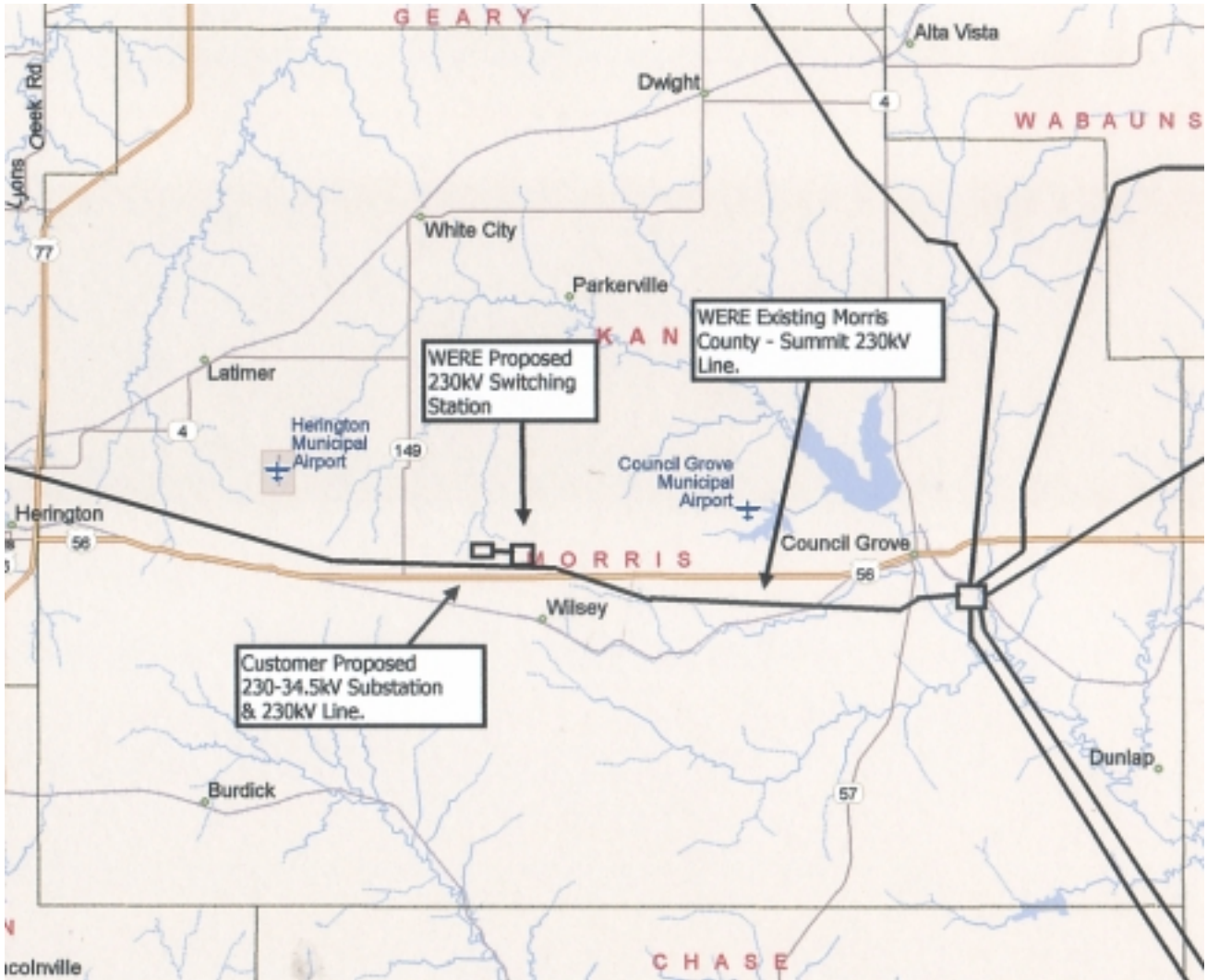

Figure 2: Map Of The Surrounding Area